

GROUP 2 ELECTRICAL CIRCUIT

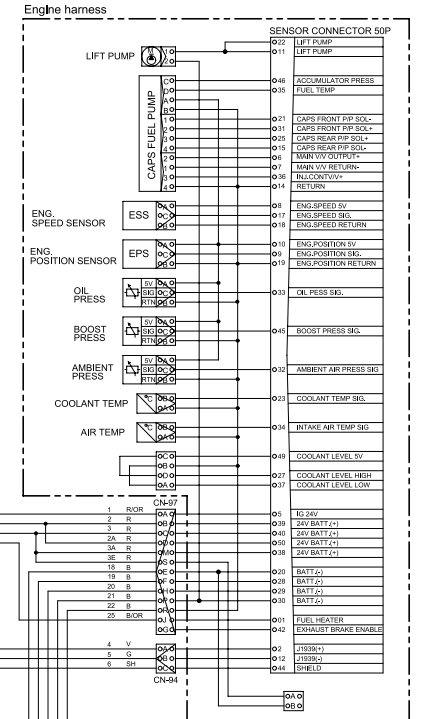
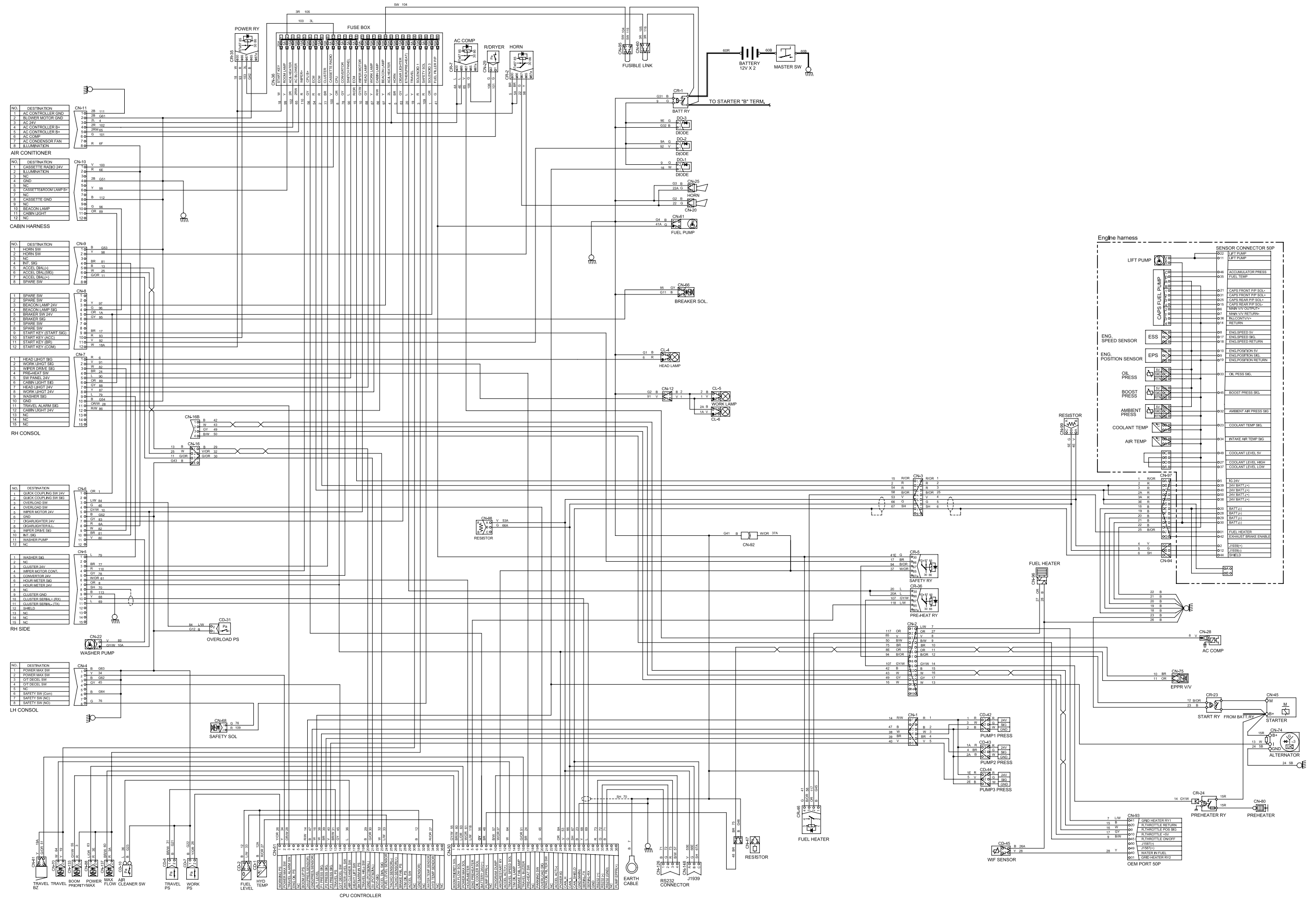

CN-11

NO.	DESTINATION	WIRING
1	AC CONTROLLER GND	28 2B 111
2	BLOWER MOTOR GND	28 2B 061
3	AC 24V	28 2B 4
4	AC CONTROLLER B+	28 2B 109
5	AC CONTROLLER B+	28 2B 068
6	AC COMP	28 2B 101
7	AC CONTROLLER FAN	28 2B 101
8	ILLUMINATION	28 2B 6F

CN-10

NO.	DESTINATION	WIRING
1	CASSETTE FUSE 24V	28 2B 100
2	ILLUMINATION	28 2B 6E
3	NC	28 2B 6E
4	GND	28 2B 061
5	NC	28 2B 061
6	CASSETTE ROOM LAMP B+	28 2B 09
7	NC	28 2B 09
8	CASSETTE GND	28 2B 112
9	NC	28 2B 112
10	BEACON LAMP	28 2B 0
11	CABIN LIGHT	28 2B 08
12	NC	28 2B 08

CN-9

NO.	DESTINATION	WIRING
1	HORN SW	28 2B 53
2	HORN SW	28 2B 58
3	NC	28 2B 53
4	INT. SIG	28 2B 81
5	ACCEL (DUAL)	28 2B 31
6	ACCEL (DUAL)	28 2B 25
7	ACCEL (DUAL)	28 2B 11
8	SPARE SW	28 2B 0

CN-8

NO.	DESTINATION	WIRING
1	SPARE SW	28 2B 0
2	SPARE SW	28 2B 0
3	BEACON LAMP 24V	28 2B 07
4	BEACON LAMP SIG	28 2B 07
5	BRAKER SW 24V	28 2B 14
6	BRAKER SW	28 2B 05
7	SPARE SW	28 2B 0
8	SPARE SW	28 2B 0
9	START KEY (START) SW	28 2B 17
10	START KEY (ACC)	28 2B 03
11	START KEY (SIG)	28 2B 03
12	START KEY (COM)	28 2B 15A

CN-7

NO.	DESTINATION	WIRING
1	HEAD LIGHT SIG	28 2B 01
2	WORK LIGHT SIG	28 2B 02
3	WIPER DRIVE SIG	28 2B 04
4	PROXIMITY SW	28 2B 04
5	SW PANEL 24V	28 2B 06
6	CABIN LIGHT SIG	28 2B 08
7	HEAD LIGHT 24V	28 2B 07
8	WORK LIGHT 24V	28 2B 07
9	WIPER SW	28 2B 04
10	GND	28 2B 04
11	TRAVEL ALARM SIG	28 2B 08
12	CABIN LIGHT 24V	28 2B 08
13	NC	28 2B 08
14	NC	28 2B 08
15	NC	28 2B 08

CN-6

NO.	DESTINATION	WIRING
1	QUICK COUPLING SW 24V	28 2B 01
2	QUICK COUPLING SW SIG	28 2B 01
3	OVERLOAD SW	28 2B 84
4	OVERLOAD SW	28 2B 84
5	WIPER MOTOR SW	28 2B 04
6	GND	28 2B 04
7	WIPER MOTOR SW	28 2B 04
8	CHARLIGHTER BLL	28 2B 8A
9	WIPER DRIVE SW	28 2B 04
10	WIPER DRIVE SW	28 2B 04
11	WIPER PUMP	28 2B 04
12	NC	28 2B 04

CN-5

NO.	DESTINATION	WIRING
1	WASHER SW	28 2B 79
2	NC	28 2B 79
3	CLUSTER 24V	28 2B 77
4	WIPER MOTOR CONT	28 2B 138
5	CONSOLE SW	28 2B 79
6	HOURLY METER SW	28 2B 81
7	HOURLY METER SW	28 2B 81
8	NC	28 2B 81
9	NC	28 2B 11A
10	CLUSTER SIGNAL (SIG)	28 2B 08
11	CLUSTER SIGNAL (TV)	28 2B 08
12	NC	28 2B 08
13	NC	28 2B 08
14	NC	28 2B 08
15	NC	28 2B 08

CN-4

NO.	DESTINATION	WIRING
1	POWER MAX SW	28 2B 34
2	POWER MAX SW	28 2B 34
3	OT FORCE SW	28 2B 05
4	OT FORCE SW	28 2B 05
5	NC	28 2B 05
6	SAFETY SW (GND)	28 2B 04
7	SAFETY SW (NC)	28 2B 04
8	SAFETY SW (NC)	28 2B 7A

CN-3

NO.	DESTINATION	WIRING
1	TRAVEL TRAVEL	28 2B 01
2	TRAVEL TRAVEL	28 2B 01
3	TRAVEL TRAVEL	28 2B 01
4	TRAVEL TRAVEL	28 2B 01
5	TRAVEL TRAVEL	28 2B 01
6	TRAVEL TRAVEL	28 2B 01
7	TRAVEL TRAVEL	28 2B 01
8	TRAVEL TRAVEL	28 2B 01
9	TRAVEL TRAVEL	28 2B 01
10	TRAVEL TRAVEL	28 2B 01
11	TRAVEL TRAVEL	28 2B 01
12	TRAVEL TRAVEL	28 2B 01
13	TRAVEL TRAVEL	28 2B 01
14	TRAVEL TRAVEL	28 2B 01
15	TRAVEL TRAVEL	28 2B 01

CN-2

NO.	DESTINATION	WIRING
1	POWER MAX SW	28 2B 34
2	POWER MAX SW	28 2B 34
3	OT FORCE SW	28 2B 05
4	OT FORCE SW	28 2B 05
5	NC	28 2B 05
6	SAFETY SW (GND)	28 2B 04
7	SAFETY SW (NC)	28 2B 04
8	SAFETY SW (NC)	28 2B 7A

CN-1

NO.	DESTINATION	WIRING
1	POWER MAX SW	28 2B 34
2	POWER MAX SW	28 2B 34
3	OT FORCE SW	28 2B 05
4	OT FORCE SW	28 2B 05
5	NC	28 2B 05
6	SAFETY SW (GND)	28 2B 04
7	SAFETY SW (NC)	28 2B 04
8	SAFETY SW (NC)	28 2B 7A

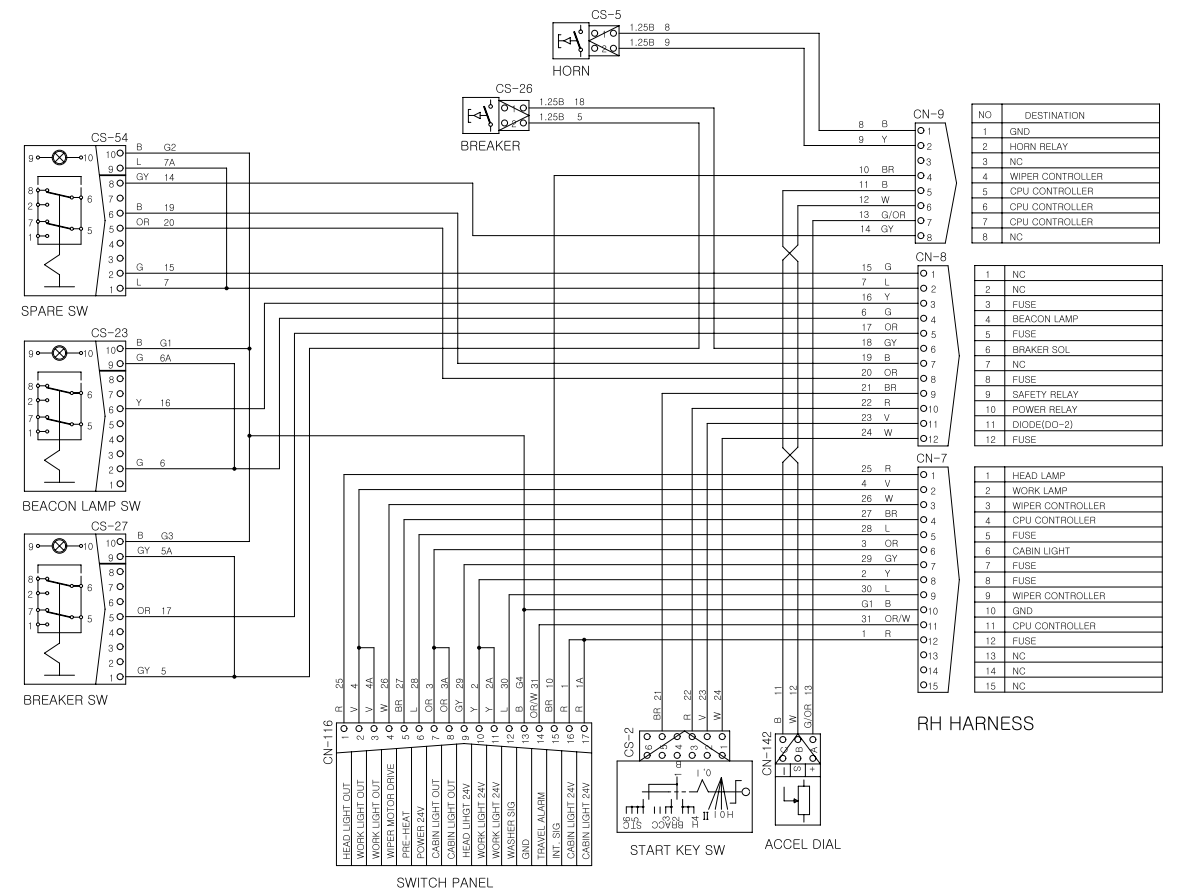
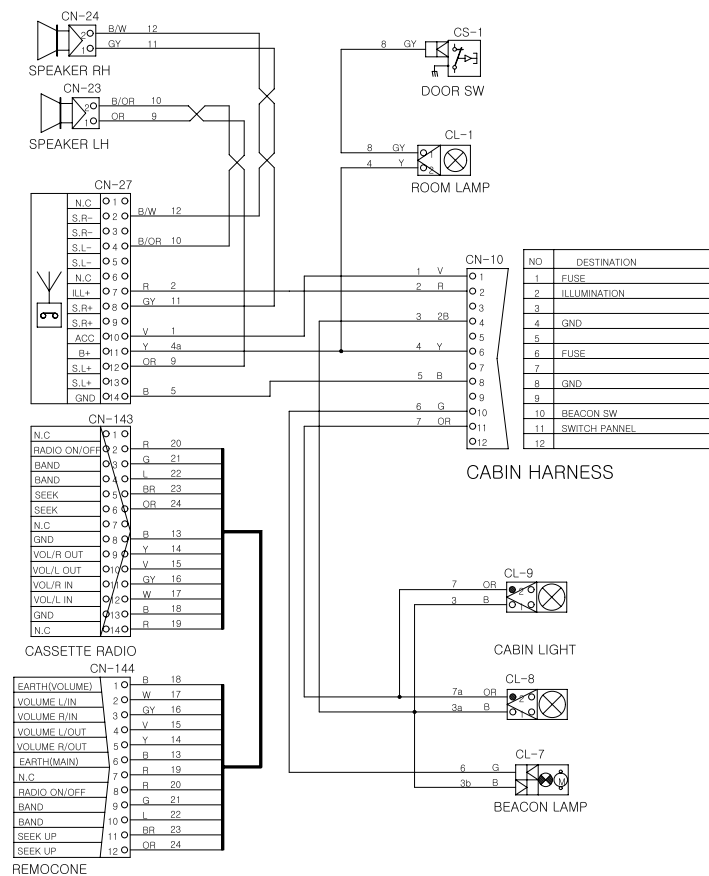
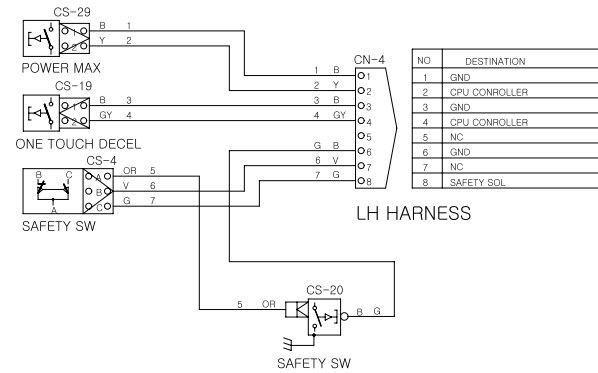
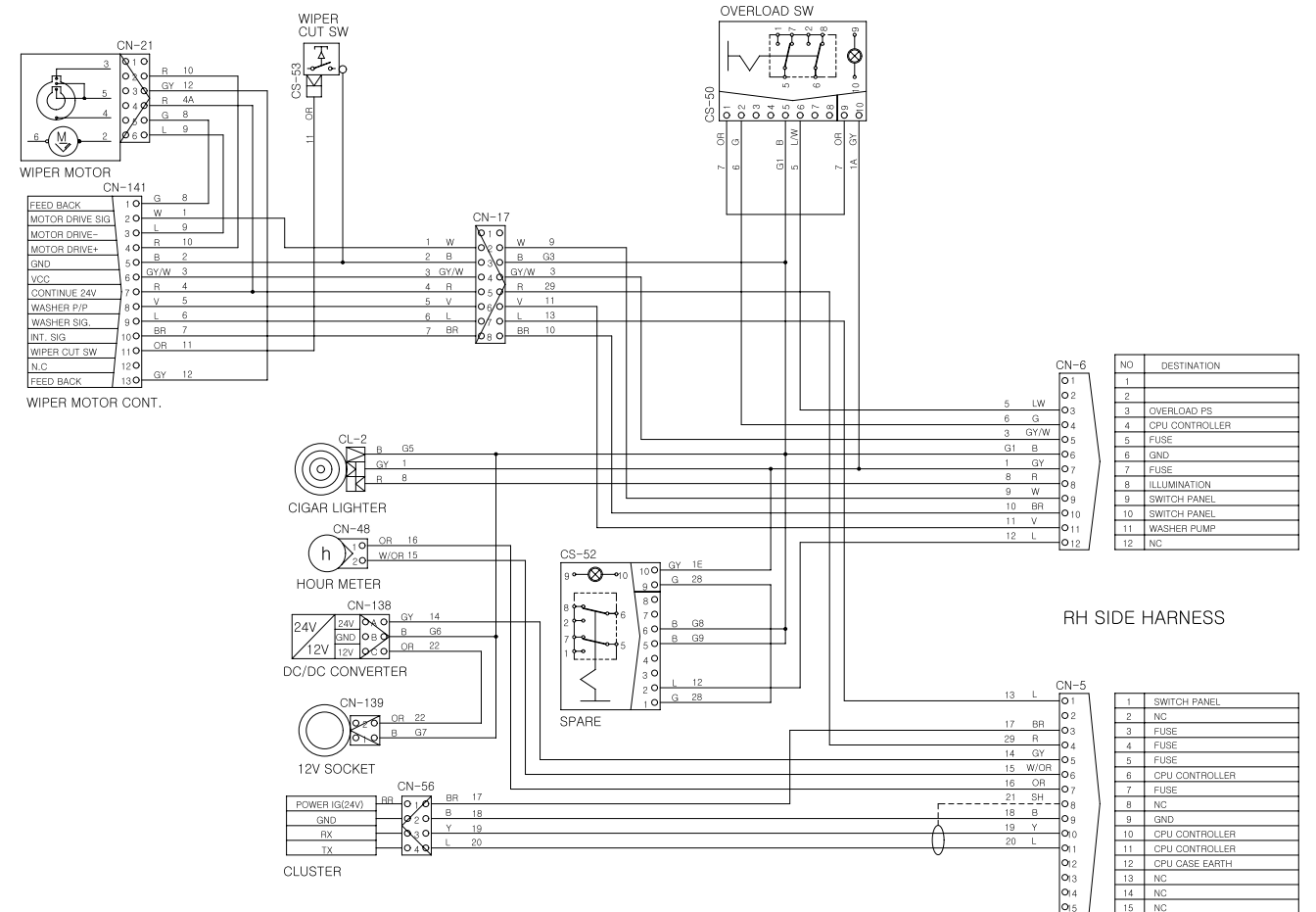
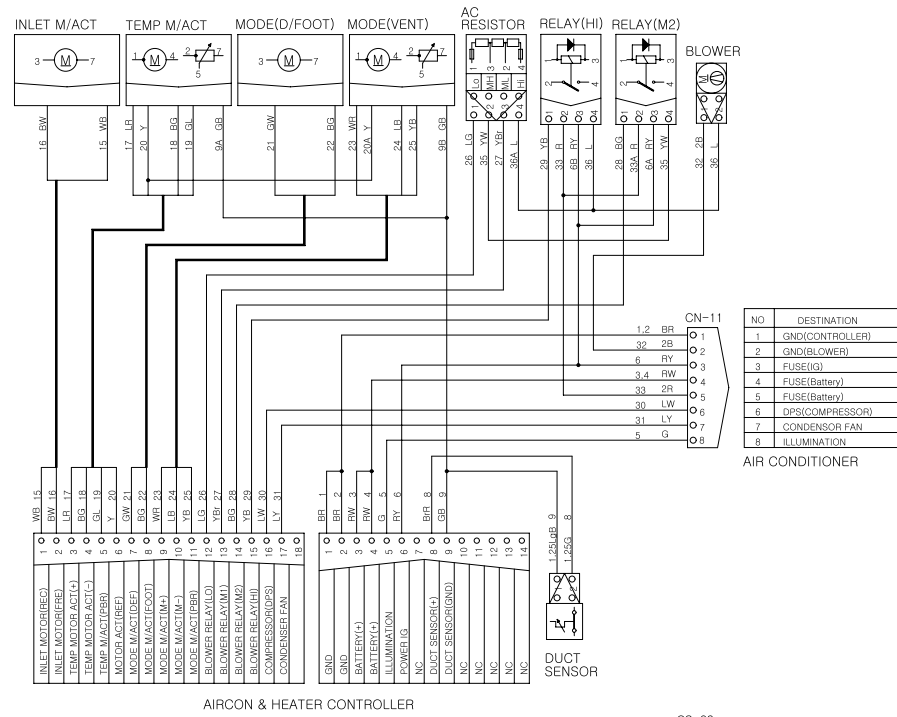

1. POWER CIRCUIT

The negative terminal of battery is grounded to the machine chassis through master switch. When the start switch is in the OFF position, the current flows from the positive battery terminal as shown below.

1) OPERATING FLOW

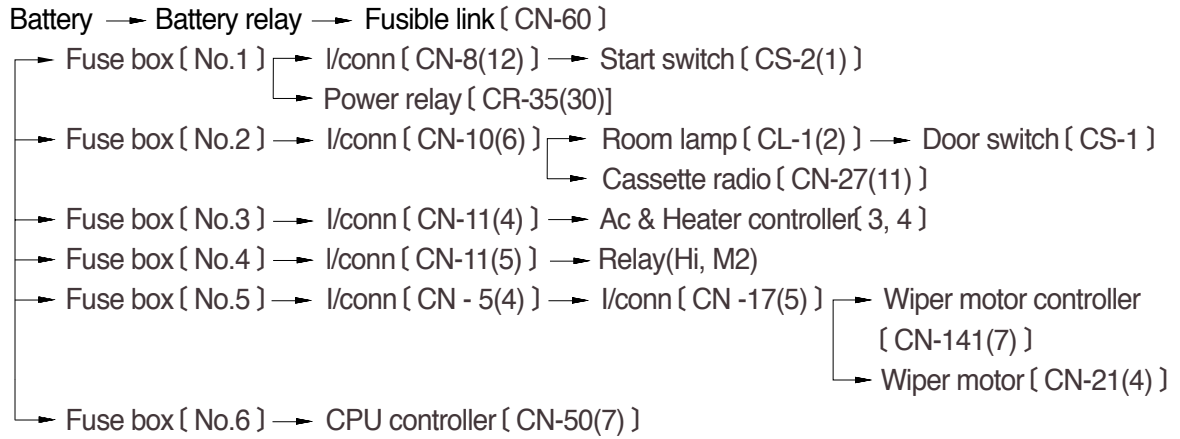

I/conn : Intermediate connector

2) CHECK POINT

Engine	Start switch	Check point	Voltage
OFF	OFF	- GND (Battery 1EA) - GND (Battery 2EA) - GND (Battery 2EA) - GND (Fusible link)	10~12.5V 20~25V 20~25V 20~25V

GND : Ground

2. STARTING CIRCUIT

1) OPERATING FLOW

Battery(+) terminal → Battery relay[CR-1] → Fusible link [CN-60] → Fuse box [No.1]
 → I/conn [CN-8(12)] → Start switch [CS-2(1)]

(1) When start key switch is in ON position

→ Start switch ON [CS-2(2)] → I/conn [CN-8(11)] → Battery relay [CR-1]
 → Battery relay operating (All power is supplied with the electric component)
 → Start switch ON [CS-2(3)] → I/conn [CN-8(10)] → Power relay [CR-35(86) (87)]
 → Fuse box [No.10]

(2) When start key switch is in START position

Start switch START [CS-2(5)] → I/conn [CN-8(9)] → Safety relay [CR-5(86) (87)]
 → I/conn [CN-2(7)] → Start relay [CR-23]

2) CHECK POINT

Engine	Start switch	Check point	Voltage
OPERATING	START	- GND(Battery) - GND(Start key) - GND(Battery relay M4) - GND(Starter B ⁺) - GND(Starter M) - GND(Start relay) - GND(Battery relay M8)	20~25V

GND : Ground

STARTING CIRCUIT

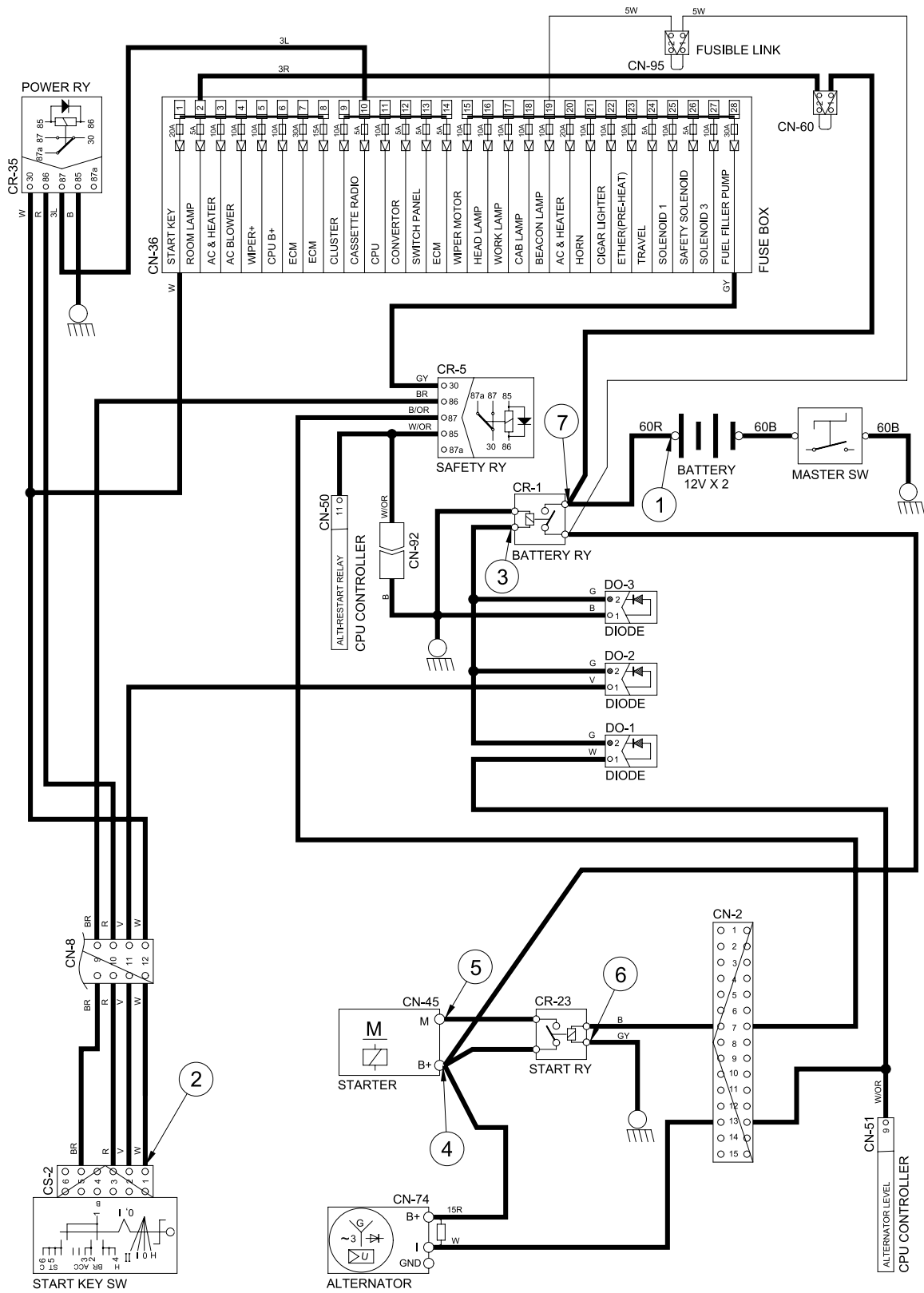

3. CHARGING CIRCUIT

When the starter is activated and the engine is started, the operator releases the key switch to the ON position.

Charging current generated by operating alternator flows into the battery through the battery relay (CR-1).

The current also flows from alternator to each electrical component and controller through the fuse box.

1) OPERATING FLOW

(1) Warning flow

Alternator "I" terminal → I/conn [CN-2(13)] → CPU alternator level [CN-51(9)]
Cluster charging warning lamp (Via serial interface)

(2) Charging flow

Alternator "B+" terminal → Battery relay (M8) → Battery (+) terminal
→ Fusible link [CN-60] → Fuse box

2) CHECK POINT

Engine	Start switch	Check point	Voltage
Run	ON	<ul style="list-style-type: none"> - GND (Battery voltage) - GND (Battery relay) - GND (Alternator B⁺ terminal) - GND (Alternator I terminal) - GND (CPU) 	20~30V

GND : Ground

CHARGING CIRCUIT

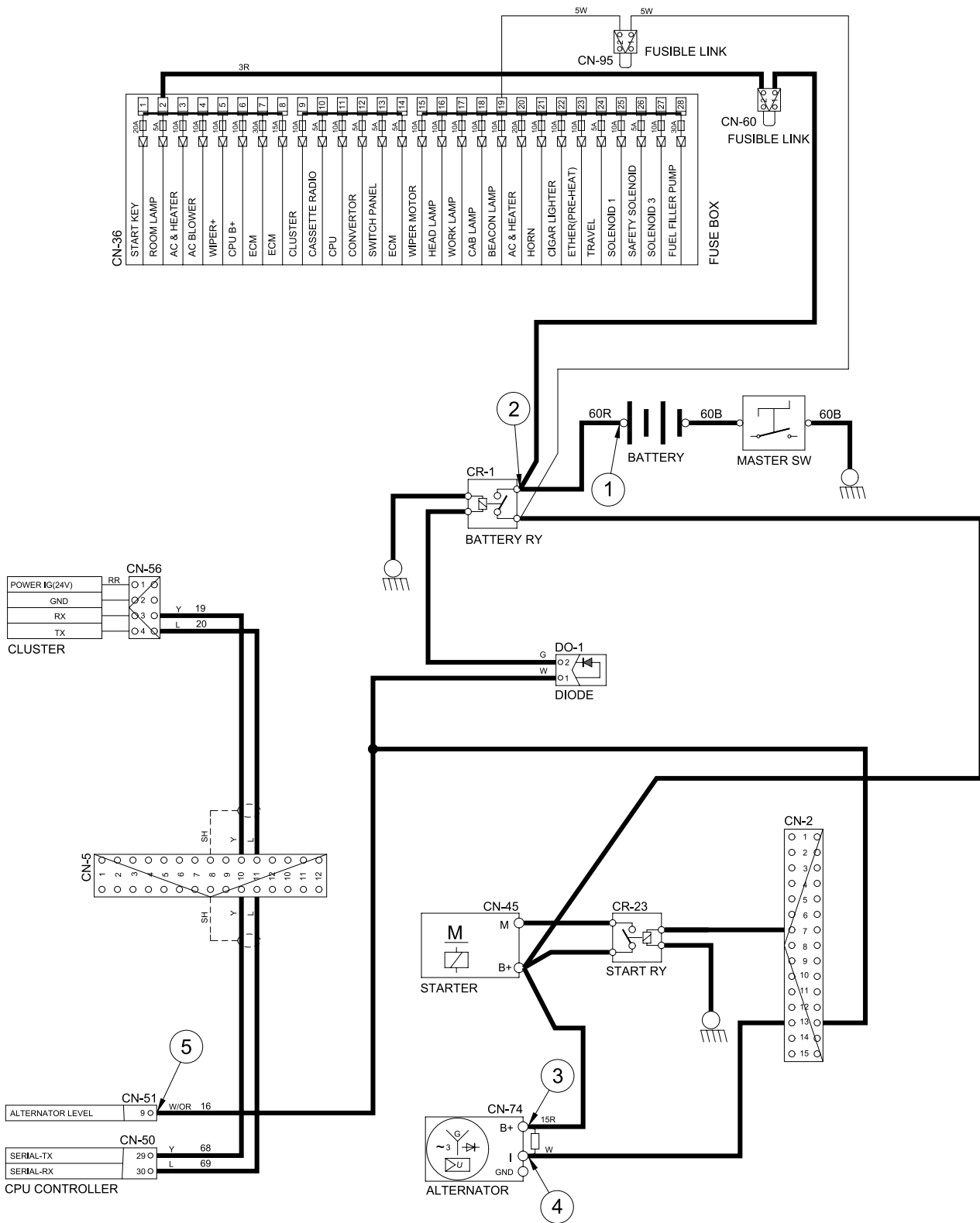

36074EL05

4. HEAD AND WORK LIGHT CIRCUIT

1) OPERATING FLOW

Fuse box (No.16) → I/conn [CN-7(7)] → Switch panel [CN-116(9)]

Fuse box (No.17) → I/conn [CN-7(8)] → Switch panel [CN-116(10,11)]

(1) Head light switch ON

Head light switch ON [CN-116(1)] → I/conn [CN-7(1)]

→ Head light ON [CL-4(1)]

→ I/conn [CN-10(2)] → Cassette radio illumination ON [CN-27(7)]

→ I/conn [CN-11(8)] → AC & Heater controller illumination ON

→ I/conn [CN-6(8)] → Cigarlight [CL-2]

(2) Work light switch ON

Work light switch ON [CN-116(2,3)] → I/conn [CN-7(2)] → I/conn [CN-12(1)]

→ Work light ON [CL-5(2), CL-6(2)]

2) CHECK POINT

Engine	Start switch	Check point	Voltage
STOP	ON	- GND(Fuse box) - GND(Switch power input) - GND(Switch power output) - GND(Head light)	20~25V
STOP	ON	- GND(Fuse box) - GND(Switch power input) - GND(Switch power output) - GND(Work light)	20~25V

GND : Ground

HEAD AND WORK LIGHT CIRCUIT

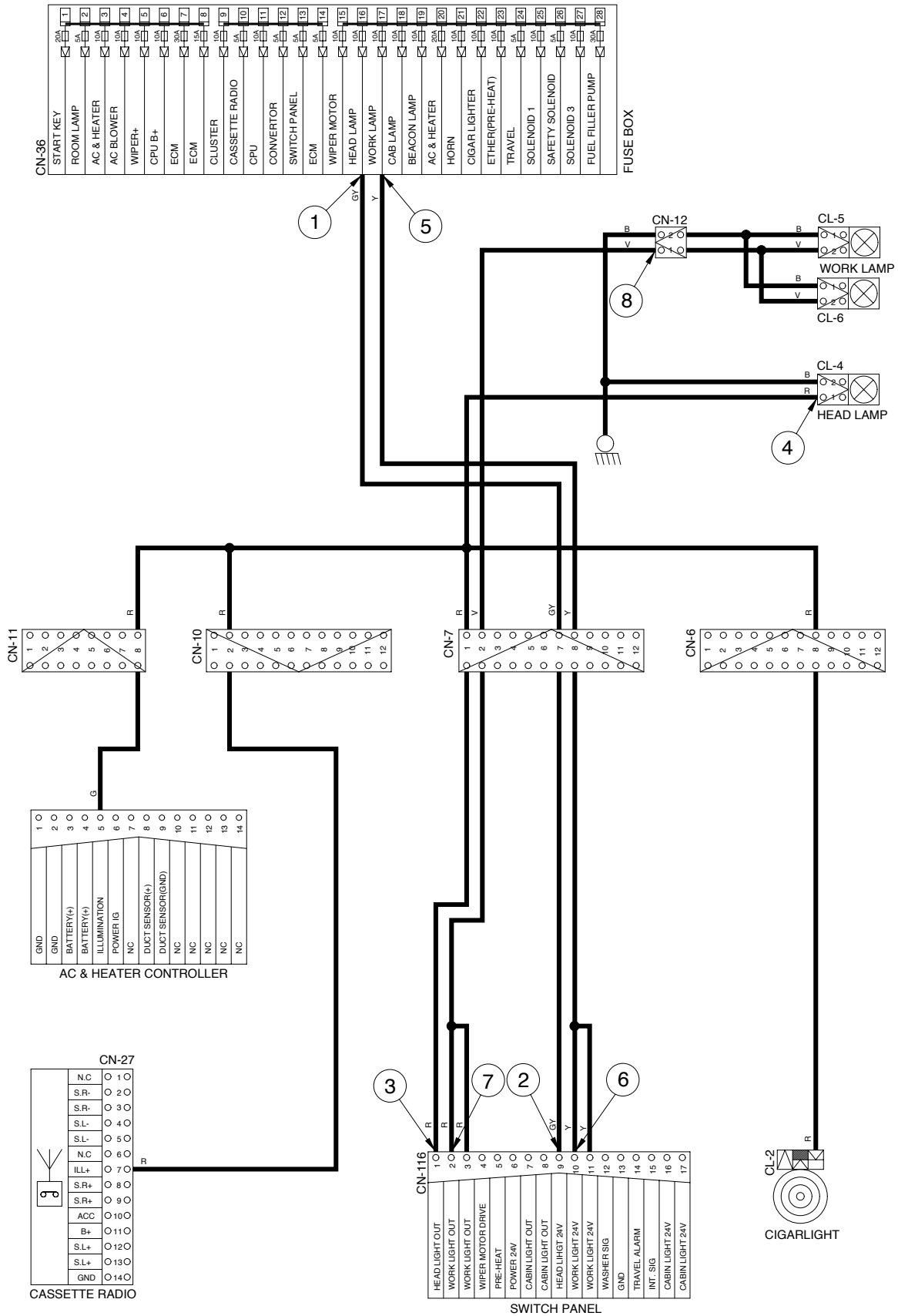

5. BEACON LAMP AND CAB LIGHT CIRCUIT

1) OPERATING FLOW

Fuse box (No.19) → I/conn [CN-8(3)] → Beacon lamp switch [CN-23(6)]

Fuse box (No.18) → I/conn [CN-7(12)] → Switch panel [CN-116(16, 17)]

(1) Beacon lamp switch ON

Beacon lamp switch ON [CS-23(2)] → Switch Indicator lamp ON [CS-23(9)]
 → I/conn [CN-8(4)] → I/conn [CN-10(10)]
 → Beacon lamp ON [CL-7]

(2) Cab light switch ON

Cab light switch ON [CN-116(7, 8)] → I/conn [CN-7(6)] → I/conn [CN-10(11)]
 → Cab light ON [CL-8(2), CL-9(2)]

2) CHECK POINT

Engine	Start switch	Check point	Voltage
STOP	ON	- GND(Fuse box) - GND(Switch power input) - GND(Switch power output) - GND(Beacon lamp)	20~25V
STOP	ON	- GND(Fuse box) - GND(Switch power input) - GND(Switch power output) - GND(Cab light)	20~25V

GND : Ground

BEACON LAMP AND CAB LIGHT CIRCUIT

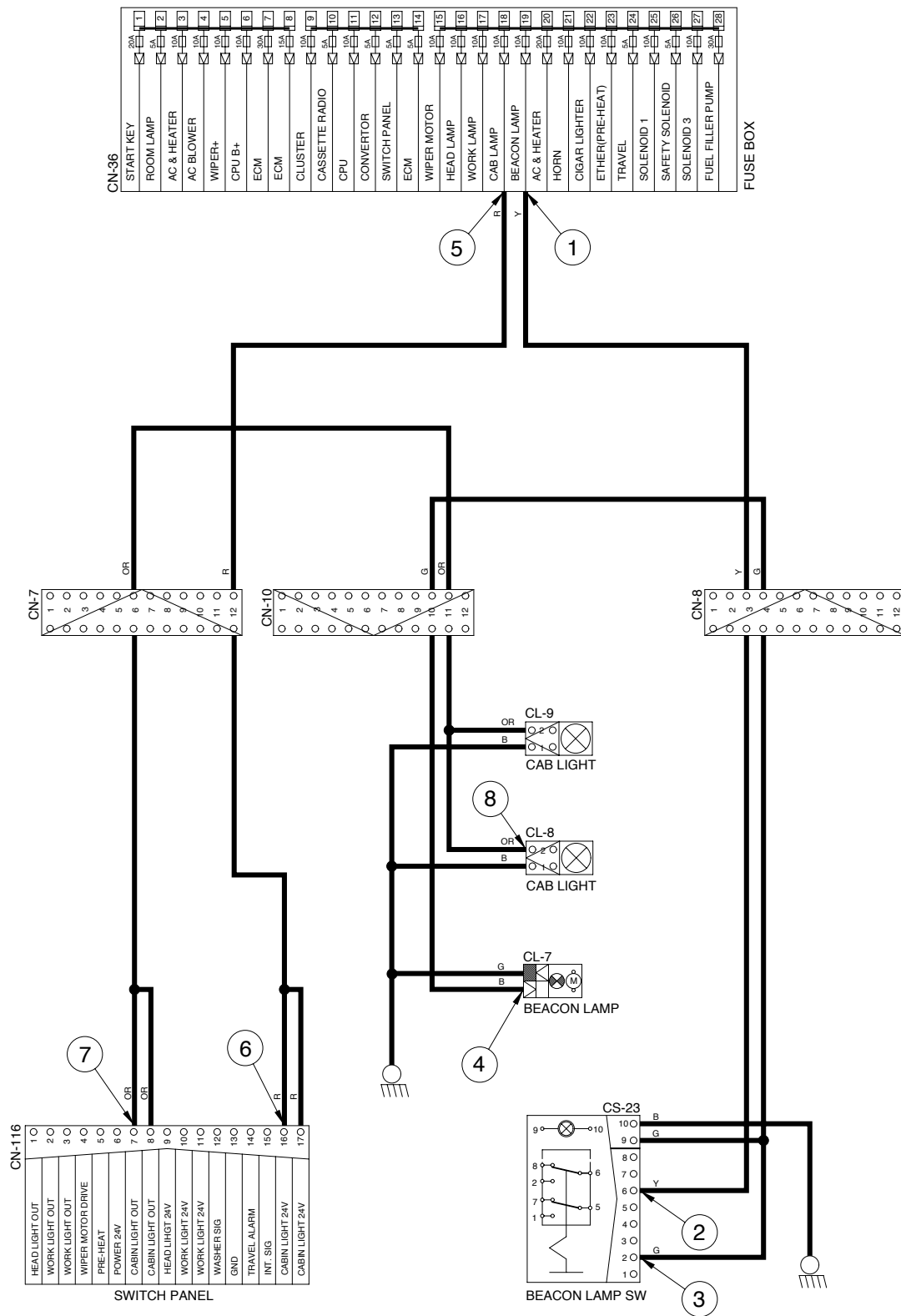

36074EL07

WIPER AND WASHER CIRCUIT

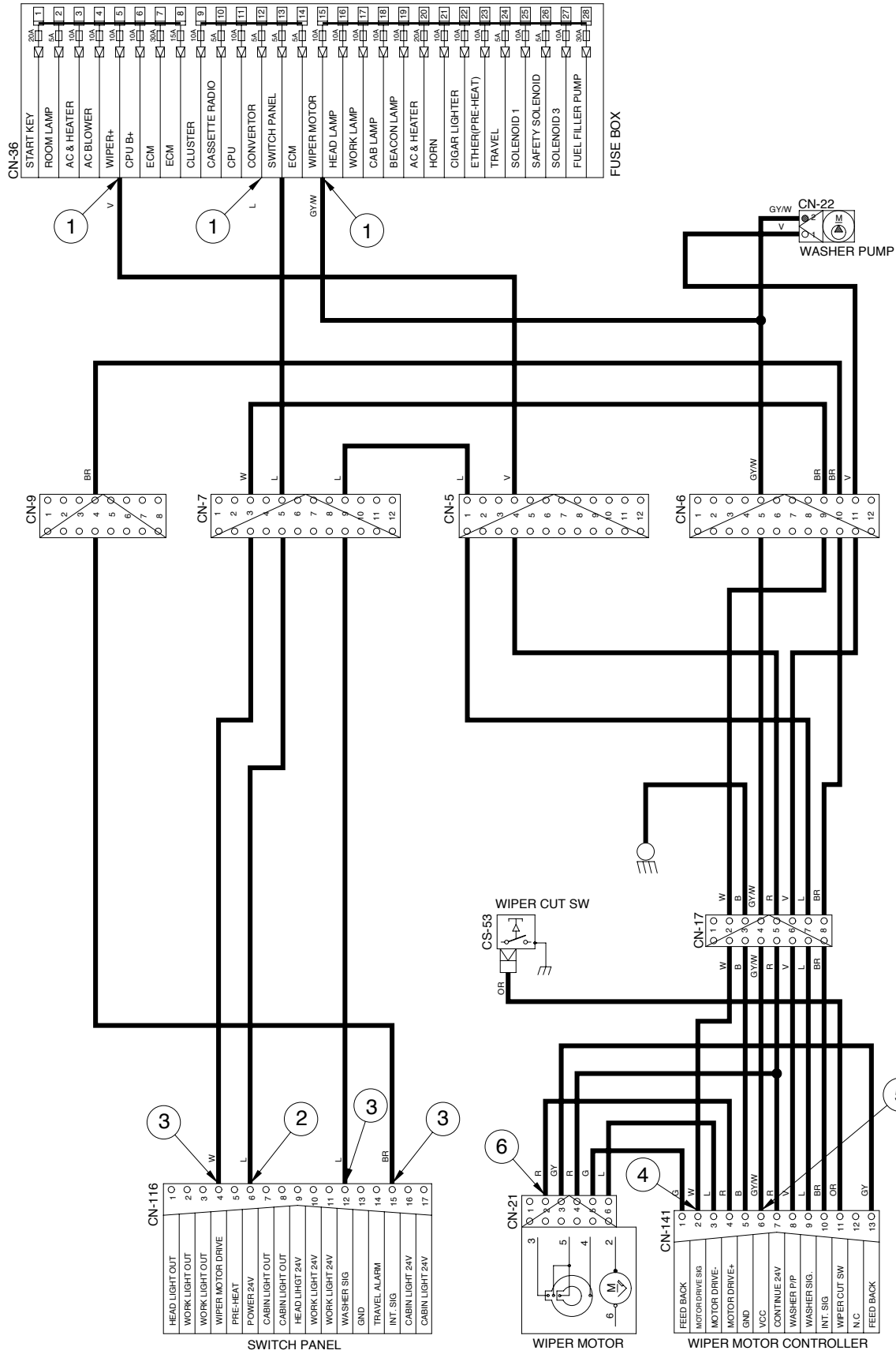

36074EL08

CONTROLLER CIRCUIT

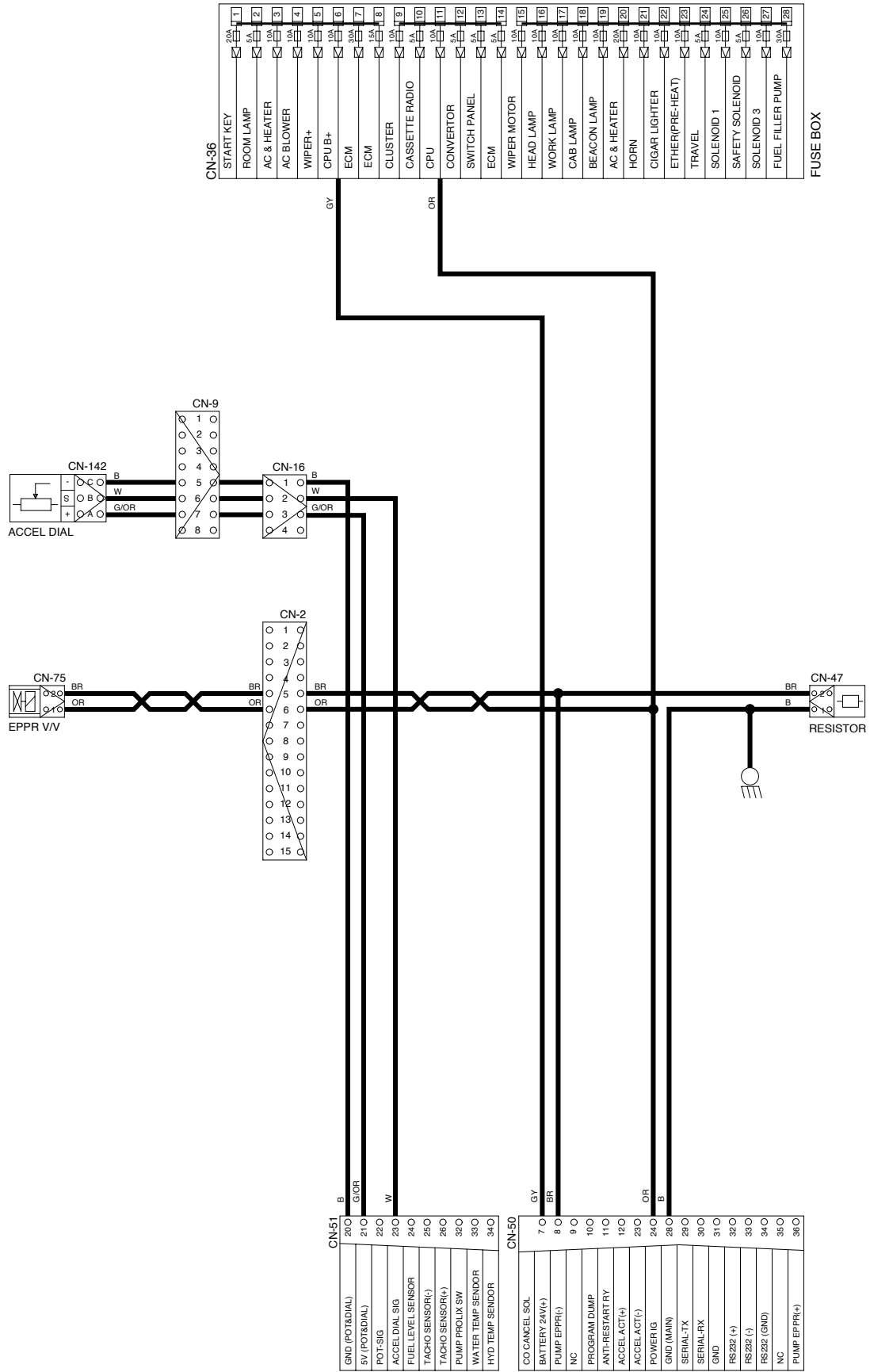

ELECTRIC CIRCUIT FOR HYDRAULIC

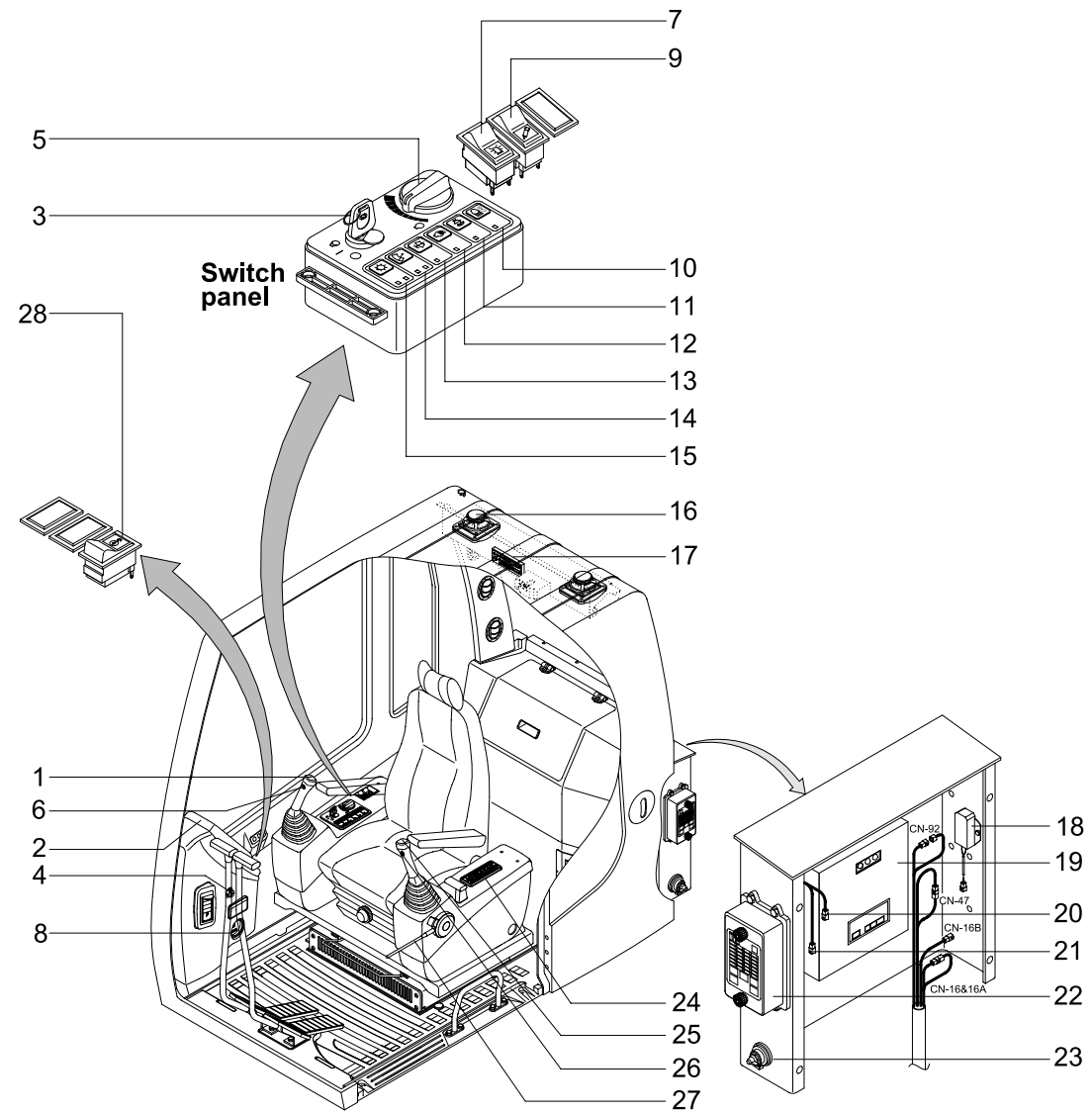

MONITORING CIRCUIT

