

GROUP 4 TRAVEL DEVICE(~#0741)

1. CONSTRUCTION

Travel device consists travel motor and gear box.

Travel motor include counter balance valve, cross over relief valve.

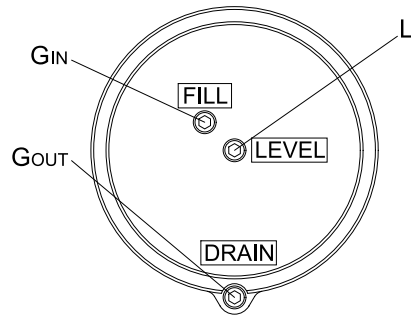
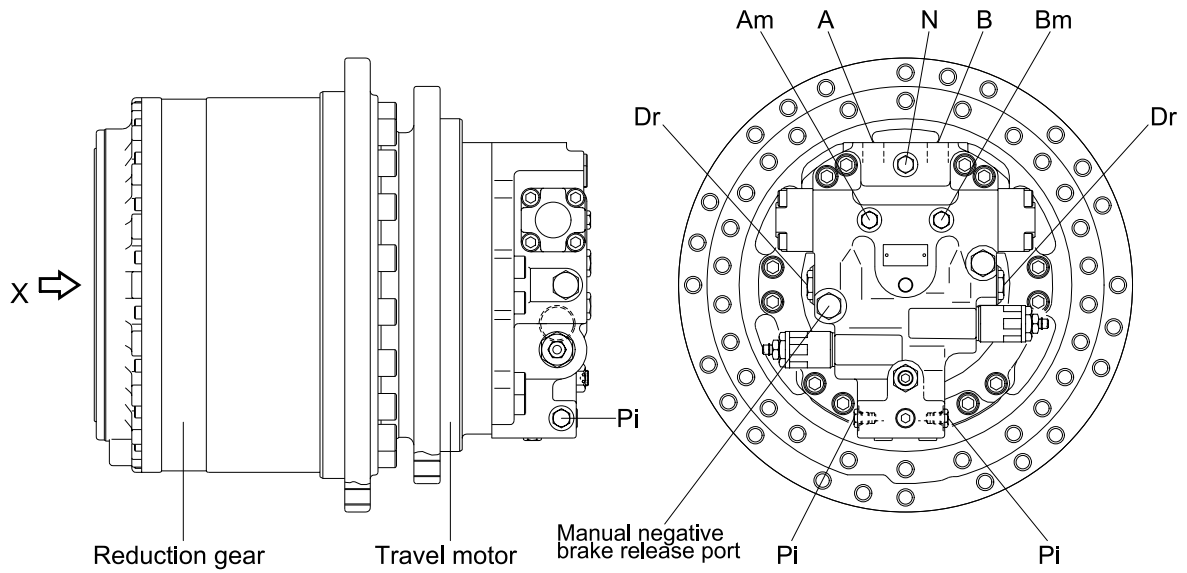

VIEW X

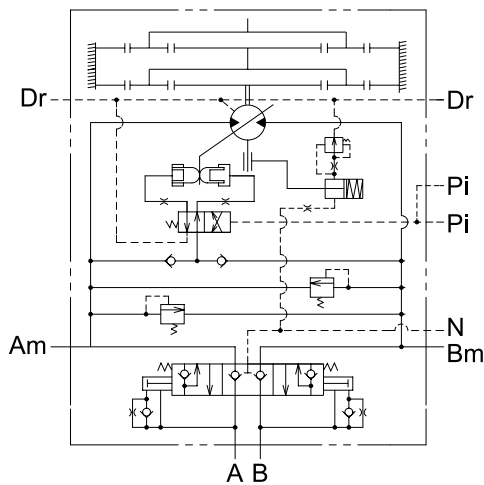

Hydraulic circuit

3607TM01

Port	Port name	Port size
A	Main port	SAE 6000 psi 1"
B	Main port	SAE 6000 psi 1"
Pi	Pilot port	PF 1/4
Dr	Drain port	PF 1/2
N	Negative brake release port	PF 1/4
Am, Bm	Test port	PF 1/4
L	Level gauge	PT 1/2
GIN	Gear oil inlet port	PT 1/2
GOUT	Gear oil drain port	PT 1/2

1) TRAVEL MOTOR(1/2)

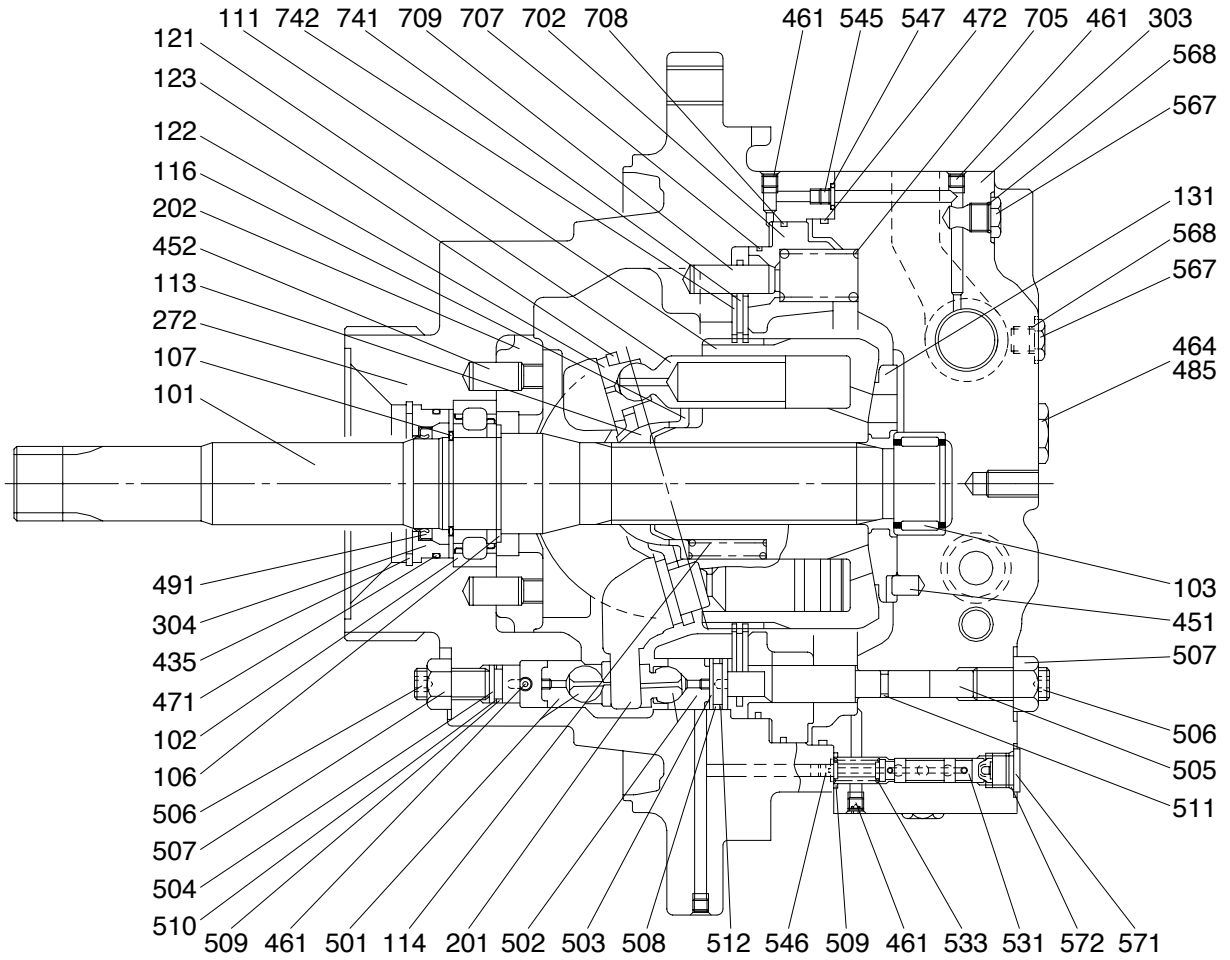

36072TM02

101	Drive shaft	304	Seal cover	510	Back up ring
102	Roller bearing	435	Snap ring	511	O-ring
103	Needle bearing	451	Pin 2	512	Back up ring
106	Bearing spacer	452	Pin 1	531	Tilting spool
107	Snap ring	461	Plug	533	Tilting spring
111	Cylinder block	471	O-ring	545	Orifice
113	Spherical bushing	472	O-ring	546	Orifice
114	Cylinder spring	491	Oil seal	547	O-ring
116	Spacer	501	Tilting piston	571	Plug
121	Piston	502	Tilting piston L	572	O-ring
122	Shoe	503	Stopper	705	Brake spring
123	Set plate	504	Stopper S	707	Piston ring 252
131	Valve plate	505	Tilting rod	708	Piston ring 278
201	Swash plate	506	Hex socket screw	709	Center pin
202	Swash plate support	507	Nut	741	Separator plate
272	Casing A	508	O-ring	742	Friction plate
303	Valve casing	509	O-ring		

TRAVEL MOTOR(2/2)

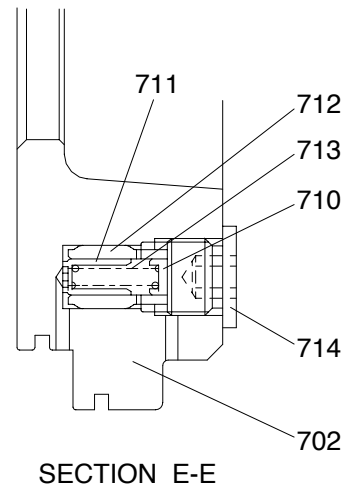
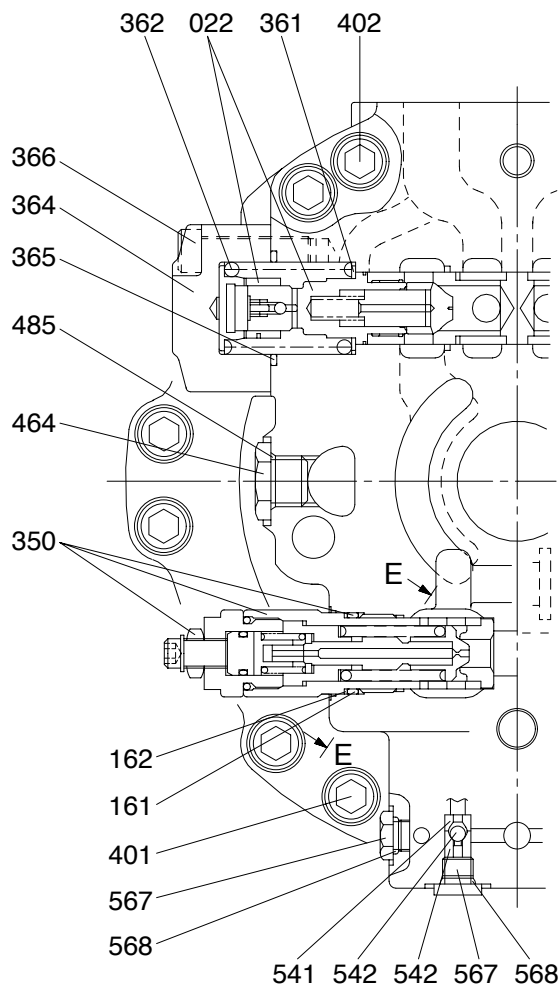

36072TM03

022	C/B Spool sub assy	366	Hex socket screw	567	VP plug
161	O-ring	401	Hex socket screw	568	O-ring
162	Back up ring	402	Hex socket screw	702	Brake piston
350	Relief valve	464	VP plug	710	Spring guide
361	Washer	485	O-ring	711	Spool
362	C/B spring	541	Seat	712	Bushing
364	C/B cover	542	Stopper	713	Spring
365	O-ring	543	Steel ball	714	RO plug

2) REDUCTION GEAR

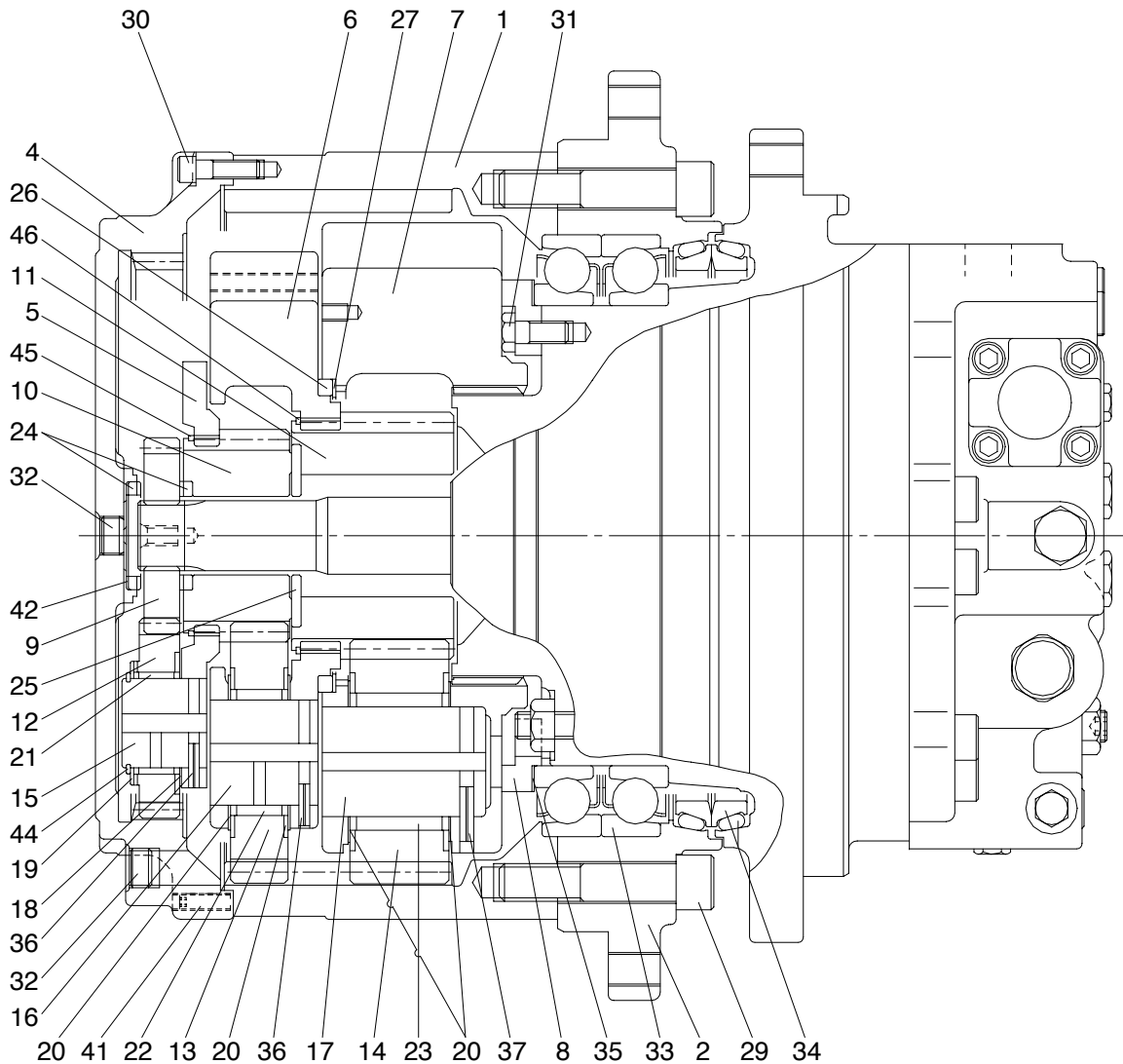

36072TRG01

1	Ring gear	16	Pin 2	31	Hex screw
2	Housing	17	Pin 3	32	PT plug
4	Side cover	18	Side plate	33	Angular bearing
5	Carrier 1	19	Side plate	34	Floating seal
6	Carrier 2	20	Side plate	35	Shim
7	Carrier 3	21	Needle cage	36	Spring pin
8	Bearing retainer	22	Needle cage	37	Spring pin
9	Sun gear 1	23	Needle cage	41	Set screw
10	Sun gear 2	24	Thrust ring	42	Shim
11	Sun gear 3	25	Thrust ring	44	Snap ring
12	Planetary gear 1	26	Thrust ring	45	Clip
13	Planetary gear 2	27	Shim	46	W clip
14	Planetary gear 3	29	Hex socket screw		
15	Pin 1	30	Hex socket screw		

2. FUNCTION

1) ROTARY GROUP

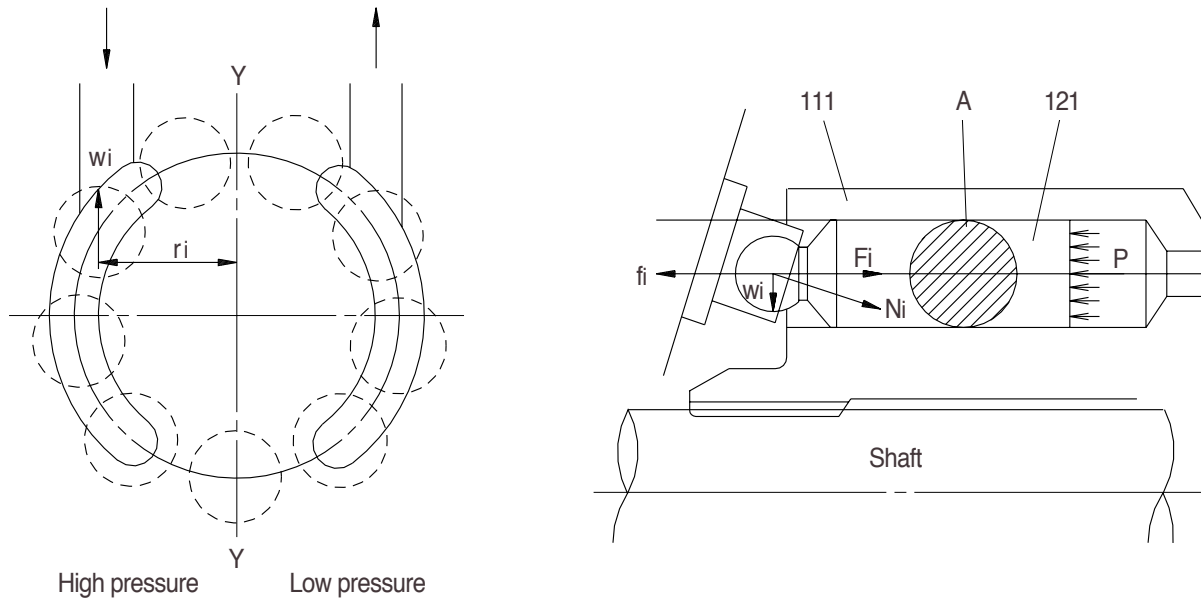

36072TRG02

The high pressure oil sent by the hydraulic pump passes through the valve casing (303) and valve plate(131) and is led into the cylinder block(111).

The motor has such construction that the above high pressure oil is led only to the cylinders on one side in respect to the line Y-Y which connects the upper and lower dead points of the stroke of the pistons(121).

The high pressure oil works on the piston(121) to push the swash plate with the force f_i ($f_i = P \times A$, where P : supply pressure, and A : pressure receiving area), and the force F_i is generated as its reaction force. This F_i is divided by the swash plate(201) having a tilting angle into the thrust component N_i and radial one W_i .

The W_i generates a torque $T_i = W_i \times r_i$ in respect to the line Y-Y.

The torque generated by each piston on the high pressure side is summed up into a resultant torque $\Sigma(r_i \times W_i)$, which produces torque for rotation.

This torque gives a rotating force to the cylinder block(111) through the pistons.

Since the cylinder block is spline-coupled with the shaft, the rotating force is transmitted to the shaft accordingly.

3) DISPLACEMENT CHANGEOVER SECTION

As a supporting mechanism for the swash plate (201) on which the shoes (122) slide, the pillar system is adopted to support the load with semi-cylindrical sliding bearings provided at both ends of the mechanism.

The capacity is changed by changing the tilting angle of this swash plate.

This is a mechanism that has the tilting angle pistons arranged opposed to each other with the swash plate inserted in between, and the tilting angle of the swash plate is decided in two positions (Large and Small) by controlling the flows to and from these piston rooms with the displacement changeover valve section.

(1) External pilot pressure : $P_i = 0$ Large displacement

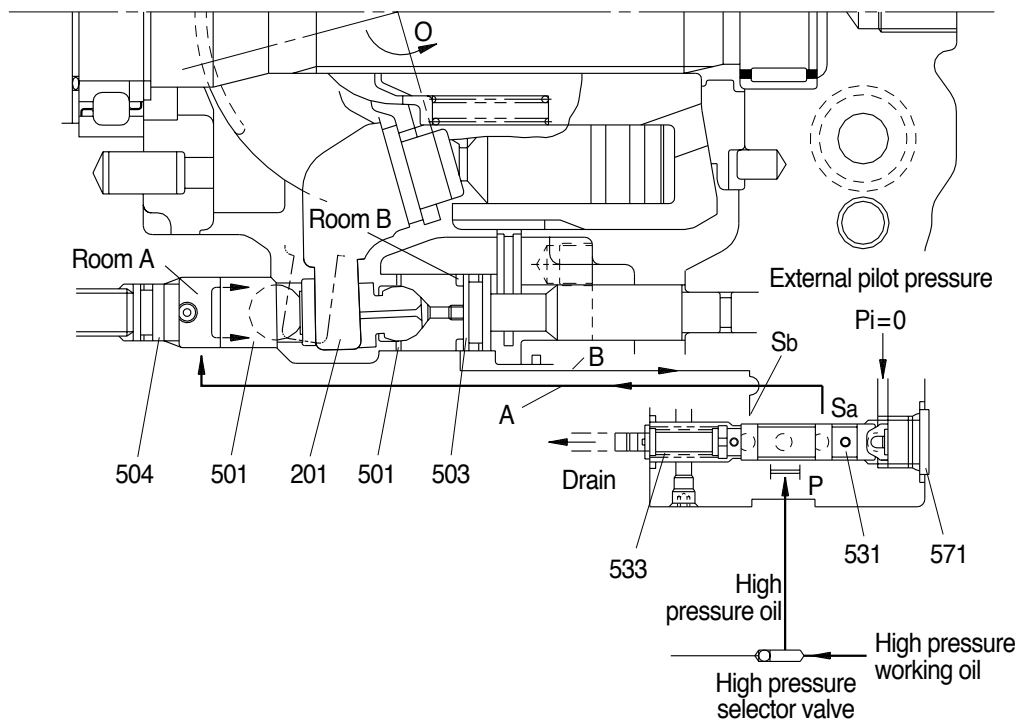

R290TM06(1)

By means of the built-in high pressure selector mechanism in the valve casing (303), the high pressure oil working on the motor functions to port P of the displacement-changeover valve. This pressure becomes the servo pressure. Since the spool (531) assembled in the displacement changeover valve is pressed to plug (571) by thy spring (533), the high pressure oil at port P flows to port Sa.

This high pressure oil flows from port Sa through the oil passage (passage A) in the valve casing and casing (272) and works to room A.

The oil in room B flows through passage B and port Sb into the drain line.

With high pressure applied, the displacement-changeover piston (501) is pushed right and the swash plate (201) moves in the arrowed direction around rotation center O. The swash plate moves until it touches stopper L (503), and then is fixed there.

(2) External pilot pressure : P_i 20kgf/cm² ——— small displacement

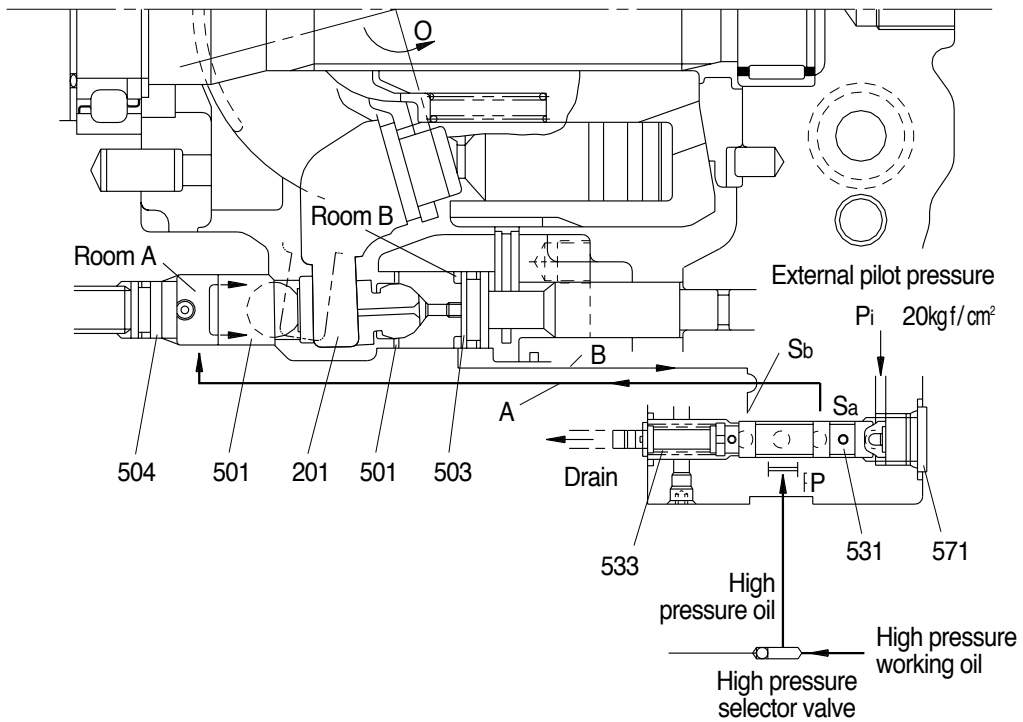

R290TM06(1)

The force working on the spool (531) of the displacement-changeover valve becomes higher than that of the spring (533), and the spool moves left. The high pressure oil flows from port P of the displacement-changeover valve through port Sb and passage B to room B where it works. The oil in room A flows through passage A and port Sa into the drain line. The displacement piston (501) is pushed left by the high pressure oil and the swash plate moves in the arrowed direction. The swash plate moves until it touched stopper S (504), and then is fixed there.

4) RELIEF VALVE

The relief valve mainly has the following two functions :

- (1) To keep the starting pressure of the hydraulic motor at a constant value and bypass to the return line excessive oil generated at the motor inlet depending upon the acceleration speed of the driven inertia.
- (2) To generate a brake pressure at the outlet during stopping of the driven inertia, and stop it forcedly.

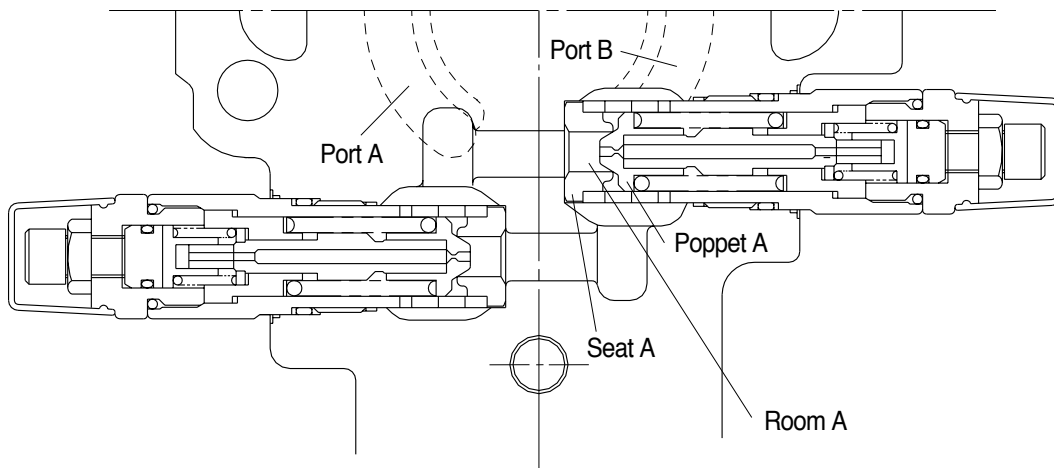

R290TM06(1)

The compartment A is always connected to port A of the motor.

When the pressure at port A increases and the force pushing poppet A is higher than the set pressure of the spring, then poppet A is pushed up from the contact surface of seat A, and oil flows from compartment A to port B.

5) NEGATIVE BRAKE

The negative brake is released applying to the brake piston (702) the pressure led through the built-in counterbalance spool sub-assembly (022).

With no pressure working, the brake force is always ensured.

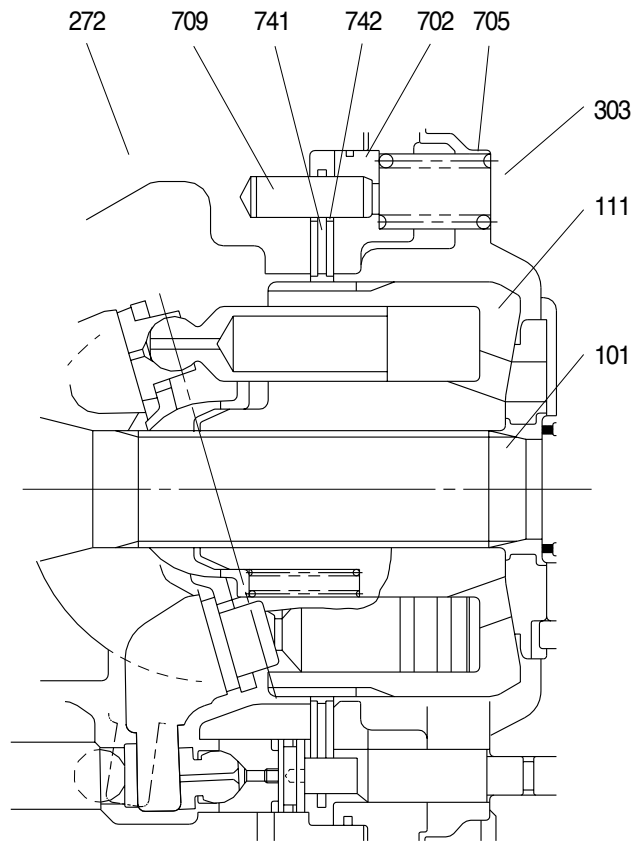

R290TM07(1)

The brake force is the friction force generated on the surfaces of the friction plates (742) spline-coupled with the cylinder block, when their rotation is restricted by the casing (272), separator plate (741), and brake piston all connected with the pins (709).

Without pressure being applied to the brake piston, the brake piston is pushed by ten brake springs (705), and the friction plate and separator plate are held between the brake piston and casing.

This holding force functions as the friction force. This friction force restrains the shaft (101) spline-coupled with the cylinder block, and thus functions the brake.

6) PRESSURE RELEASE VALVE (flow control valve)

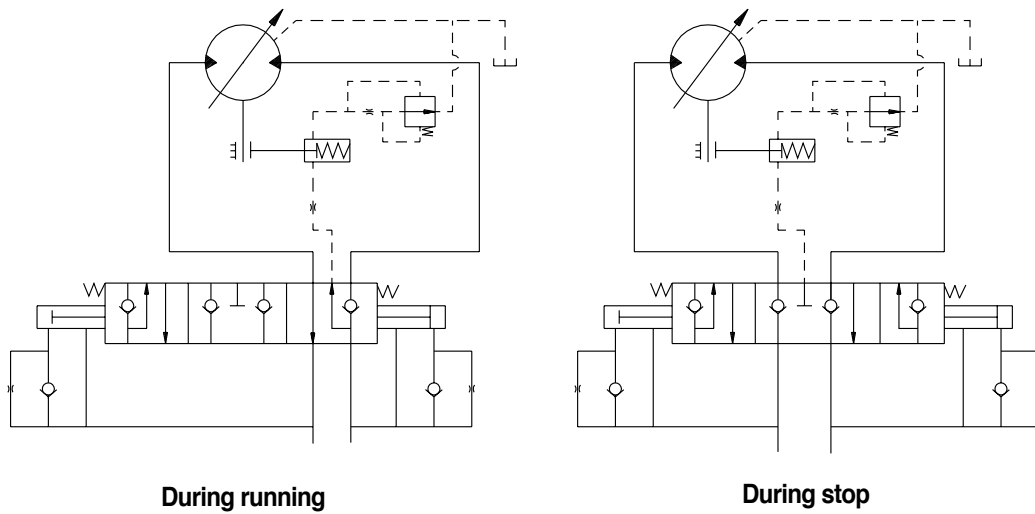

R290TM07(2)

This brake is of a back pressure-insensitive type. In other words, since the counterbalance spool used is overlapped at the neutral position, the pressure release valve prevents the circuit back pressure from working into the brake room when the machine stops traveling and works, and so the specified brake torque is available even on a slope.

During normal traveling, the pressure coming through the counterbalance valve is applied to the brake room to release the break, and is also applied to the pressure release valve section.

This pressure release valve is of a constant differential pressure type, and irrespective of the working pressure, the passing flow is constant and approximately 1 to 2 / min.

When the condition changes from traveling to stop, the counterbalance spool returns to its neutral position. With the counterbalance spool at its neutral position, the brake piston is pushed by the brake spring, and the oil in the brake room flows to the motor drain line via the pressure release valve. Then the brake torque is generated.

7) RELEASING METHOD OF NEGATIVE BRAKE

In releasing the negative brake without applying the brake releasing pressure, follow the procedures shown below.

Details of work	Tools
Remove two plugs (464) from the valve casing (303).	Double (single)-ended wrench (27mm)
Tighten an M16 screw of 130mm in length into a tapped hole of the brake piston (702), and pull out the brake piston. Then the condition having the brake release pressure is attained and the brake is released.	Hexagon bar spanner (14mm)

Note : Even with the negative brake released, the hydraulic motor will not turn. When it is difficult to generate the working pressure due to failure of the pump or so, and the whole machine is to be pulled for transportation without removing the hydraulic motor, connect pressure measurement ports A_M and B_M with a short hose or something. Then the machine can be pulled slowly.

8) REDUCTION GEAR

The reduction gear is composed of a three-stage planetary gear mechanism shown in the following figure. Since the sun gear is designed to have a floating mechanism, errors of the gears and carrier pin hole pitches will not affect the gears' lives heavily.

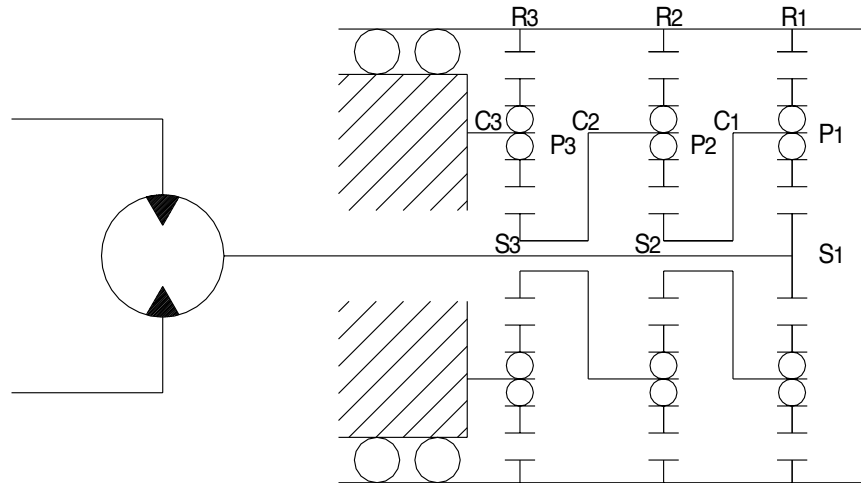

R290TM08(1)

The input rotation of the hydraulic motor is transmitted to No. 1 sun gear (S1) and this drives No. 1 planetary gears (P1). This No. 1 planetary gears (P1) drive No.1 ring gear (R1) with the same force as the meshing tangential force with No. 1 sun gear (S1), and also No. 1 carrier (C1) with the same force as the meshing reaction force. In other words, No. 1 planetary gears (P1) revolve rotating. This rotation of No. 1 carrier (C1) becomes the output of the 1st stage, and is transmitted directly to No. 2 sun gear (S2).

(No. 1 carrier is spline-coupled with No. 2 sun gear.) Similarly the revolution of No. 2 planetary gear (P2) are transmitted via No.2 carrier (C2) to No. 3 sun gear (S3). Since No. 3 carrier (C3) supporting No. 3 planetary gears (P3) are fixed, No. 3 planetary gears (P3) do not revolve, but rotates to drive No. 3 ring gears (R3).

Therefore, the rotating case is driven by the overall driving torque of numbers.

1, 2 and 3 ring gears. This reduction ratio is expressed as shown below:

$$i = \frac{(Z_{S1} + Z_{R1}) (Z_{S2} + Z_{R2}) (Z_{S3} + Z_{R3})}{Z_{S1} \cdot Z_{S2} \cdot Z_{S3}} - 1$$

where Z : Number of teeth of each gear

The direction of rotation is reverse to that of the input shaft.

GROUP 4 TRAVEL DEVICE(#0742~)

1. CONSTRUCTION

Travel device consists travel motor and gear box.

Travel motor include counter balance valve, cross over relief valve.

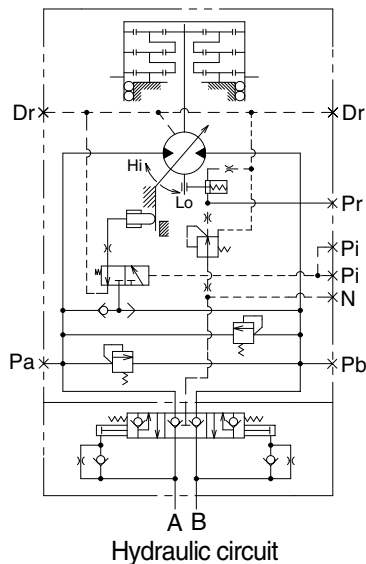
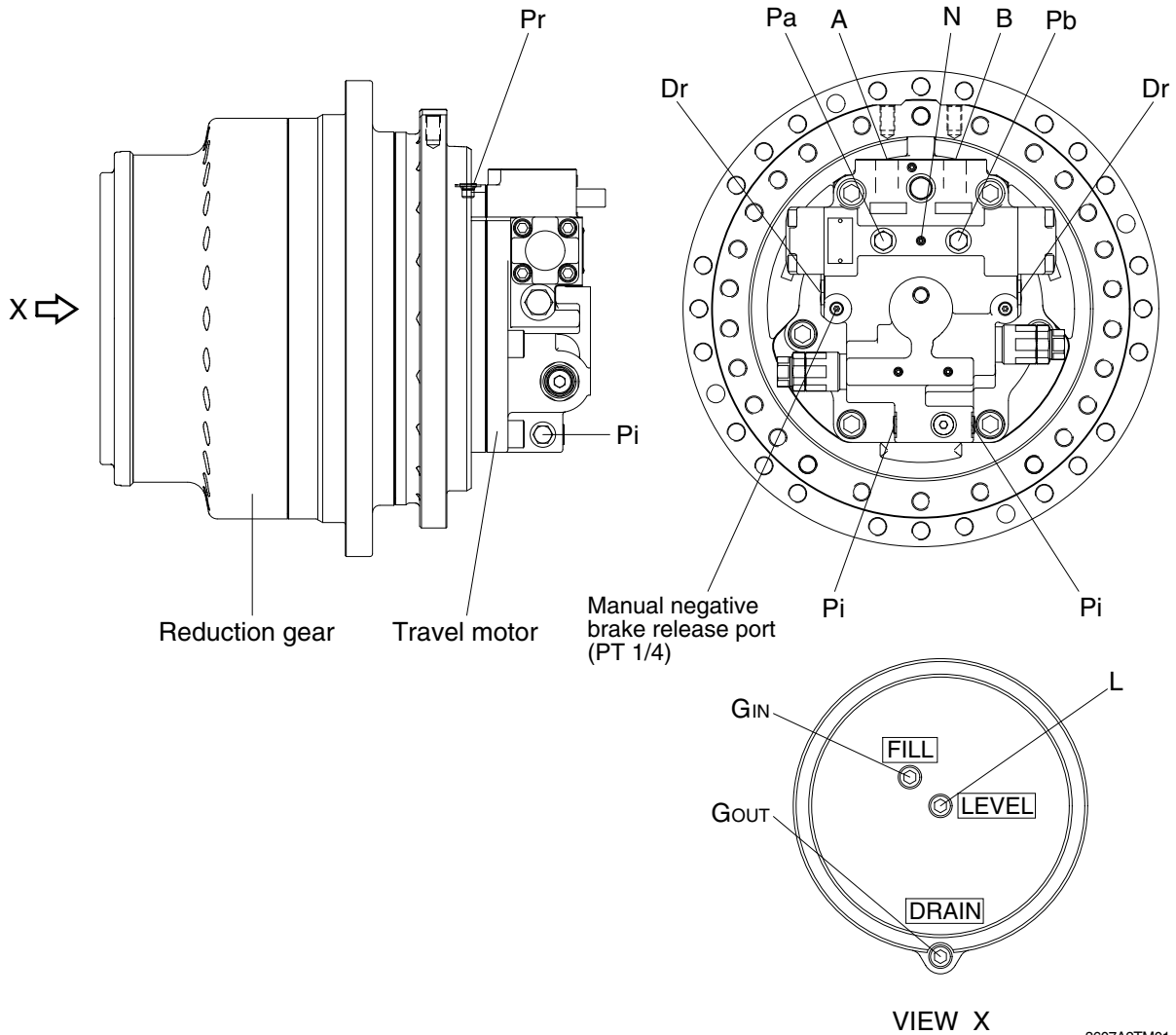

3607A2TM01

Port	Port name	Port size
A	Main port	SAE 6000 psi 1"
B	Main port	SAE 6000 psi 1"
Pi	Pilot port	PF 1/4
Dr	Drain port	PF 1/2
N	Negative brake release port	NPTF 1/16
Pa, Pb	Pressure gauge port	PF 1/4
Pr	Brake release pressure gauge port	PF 1/4
L	Level gauge	PF 1/2
G _{IN}	Gear oil inlet port	PF 1/2
G _{OUT}	Gear oil drain port	PF 1/2

1) TRAVEL MOTOR(1/2)

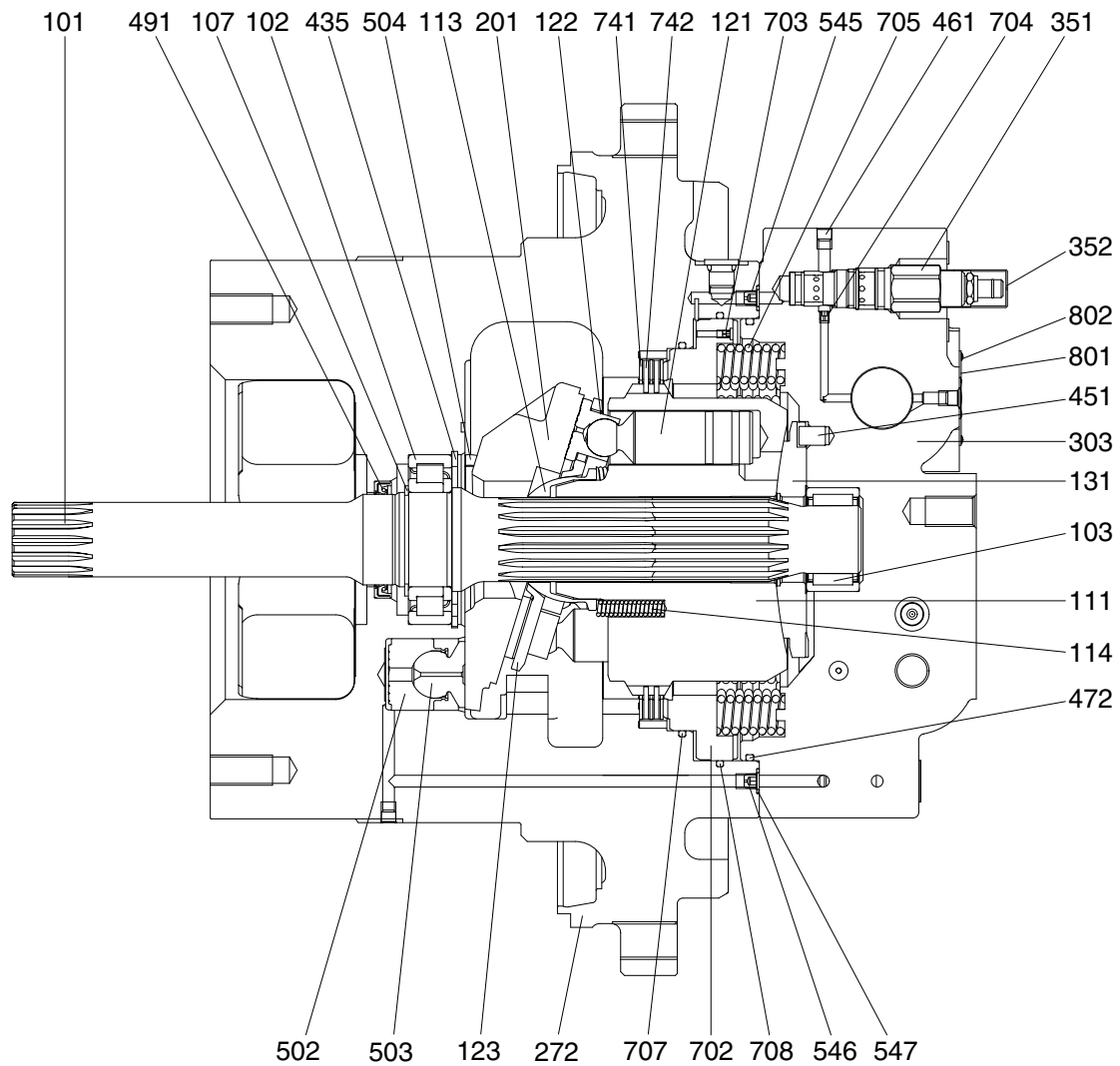

3607A2TM02

101 Drive shaft	303 Valve casing	547 O-ring
102 Roller bearing	351 Reducing valve	702 Brake piston
103 Needle bearing	352 Cover	703 Orifice
107 Snap ring	435 Snap ring	704 Orifice
111 Cylinder block	451 Pin	705 Brake spring
113 Spherical bushing	461 Plug	707 O-ring
114 Cylinder spring	472 O-ring	708 O-ring
121 Piston	491 Oil seal	741 Separation plate
122 Shoe	502 Piston	742 Friction plate
123 Set plate	503 Shoe	801 Name plate
131 Valve plate	504 Pivot ball	802 Rivet
201 Swash plate	545 Orifice	
272 Shaft casing	546 Orifice	

TRAVEL MOTOR(2/2)

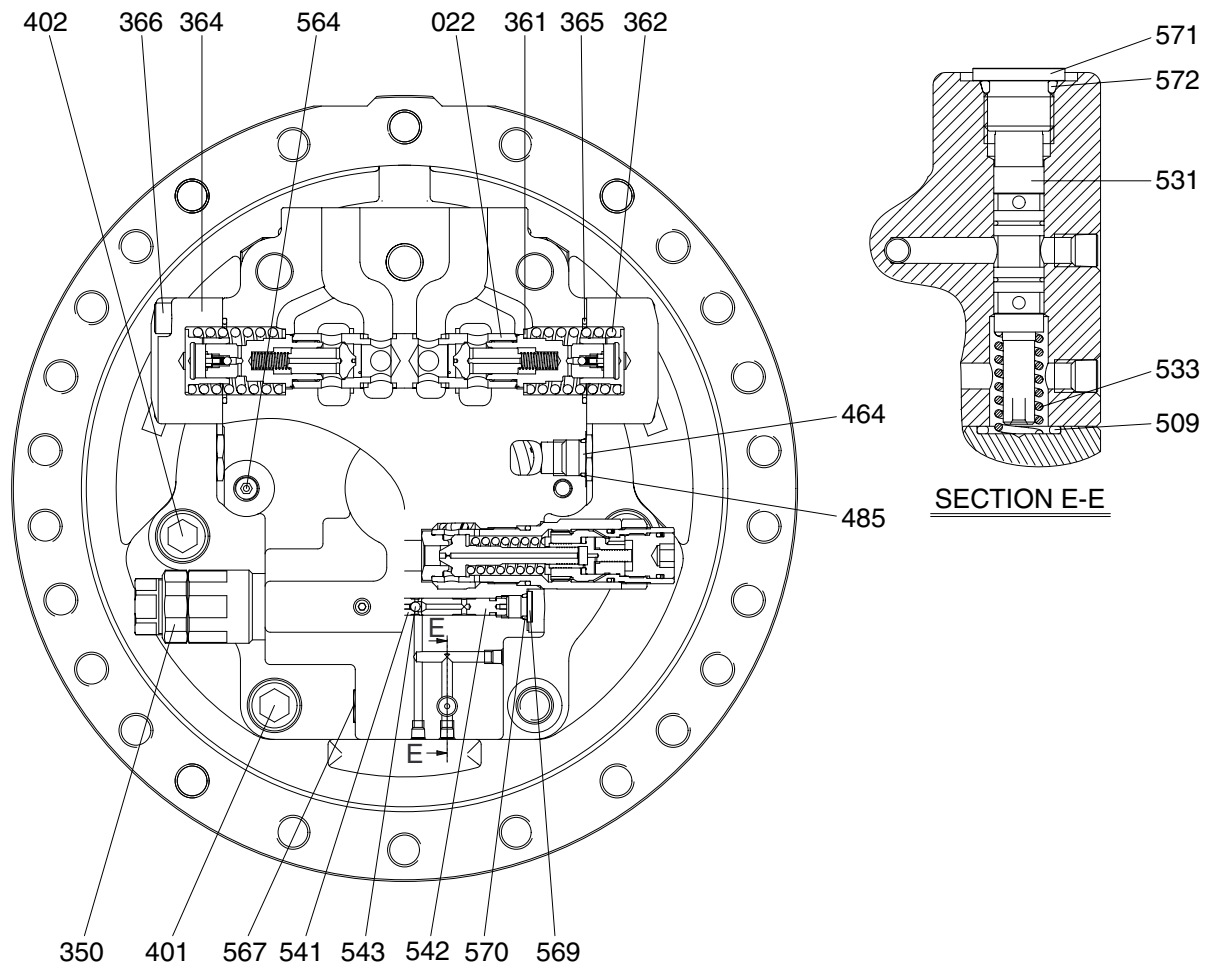

3607A2TM03

022 Counterbalance spool	402 Hex socket bolt	543 Steel ball
350 Relief valve	464 VP plug	564 Plug
361 Washer	485 O-ring	567 VP plug
362 Counterbalance spring	509 O-ring	569 RO plug
364 Counterbalance cover	531 Tilting spool	571 RO plug
365 O-ring	533 Tilting spring	572 O-ring
366 Hex socket bolt	541 Seat	
401 Hex socket bolt	542 Stopper	

2) REDUCTION GEAR

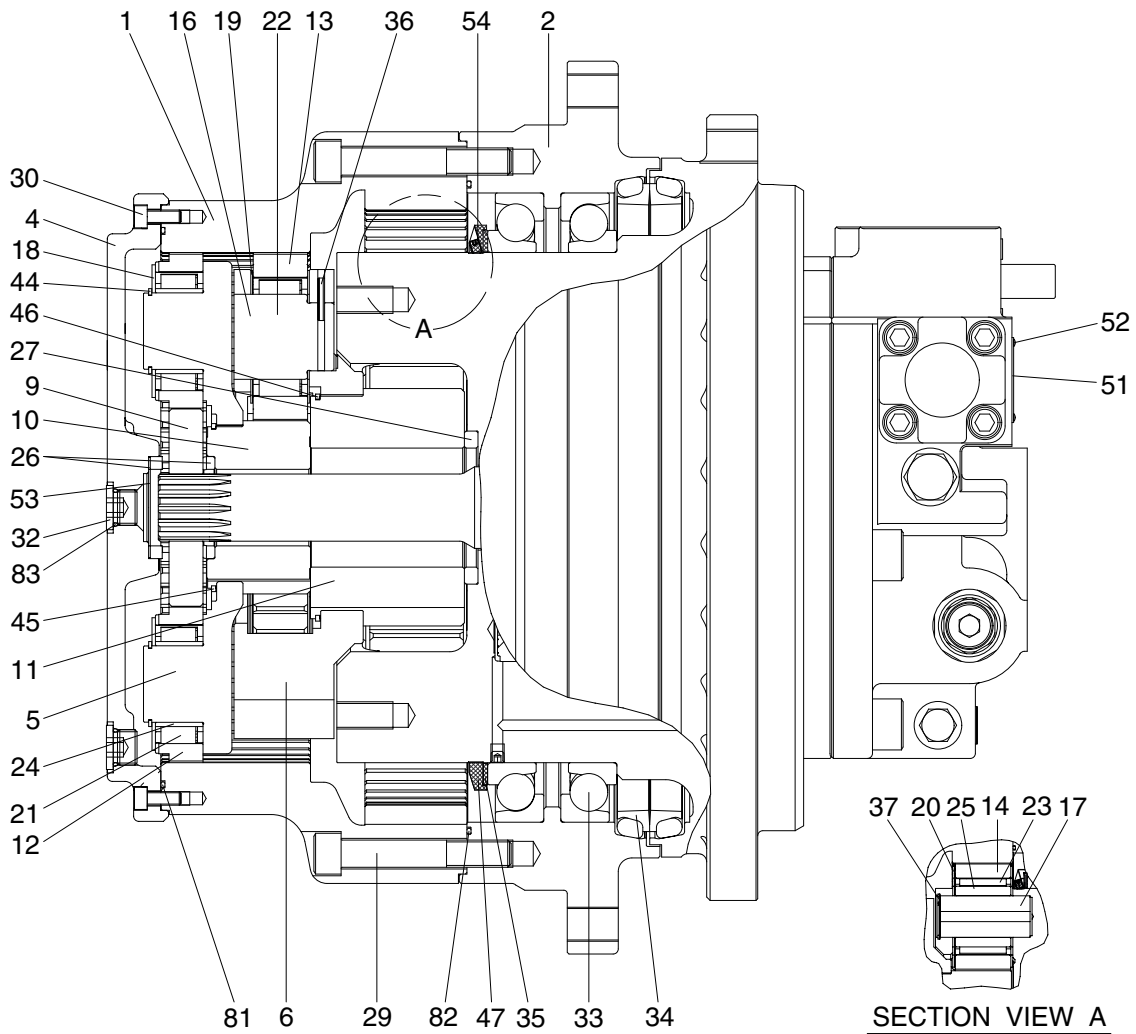

1	Ring gear	19	Side plate	35	Shim
2	Housing	20	Side plate	36	Spring pin
4	Side cover	21	Needle cage	37	Snap ring
5	Carrier 1	22	Needle cage	44	Snap ring
6	Carrier 2	23	Needle cage	45	Clip
9	Sun gear 1	24	Inner ring	46	W clip
10	Sun gear 2	25	Floating bushing	47	Nut ring
11	Sun gear 3	26	Thrust ring	51	Name plate
12	Planetary gear 1	27	Thrust ring	52	Rivet
13	Planetary gear 2	29	Socket bolt	53	Washer
14	Planetary gear 3	30	Socket bolt	54	Set screw
16	Pin 2	32	RO plug	81	O-ring
17	Pin 3	33	Angular bearing	82	O-ring
18	Side plate	34	Floating seal	83	O-ring

3607A2TRG01

2. FUNCTION

1) GENERATION OF TORQUE

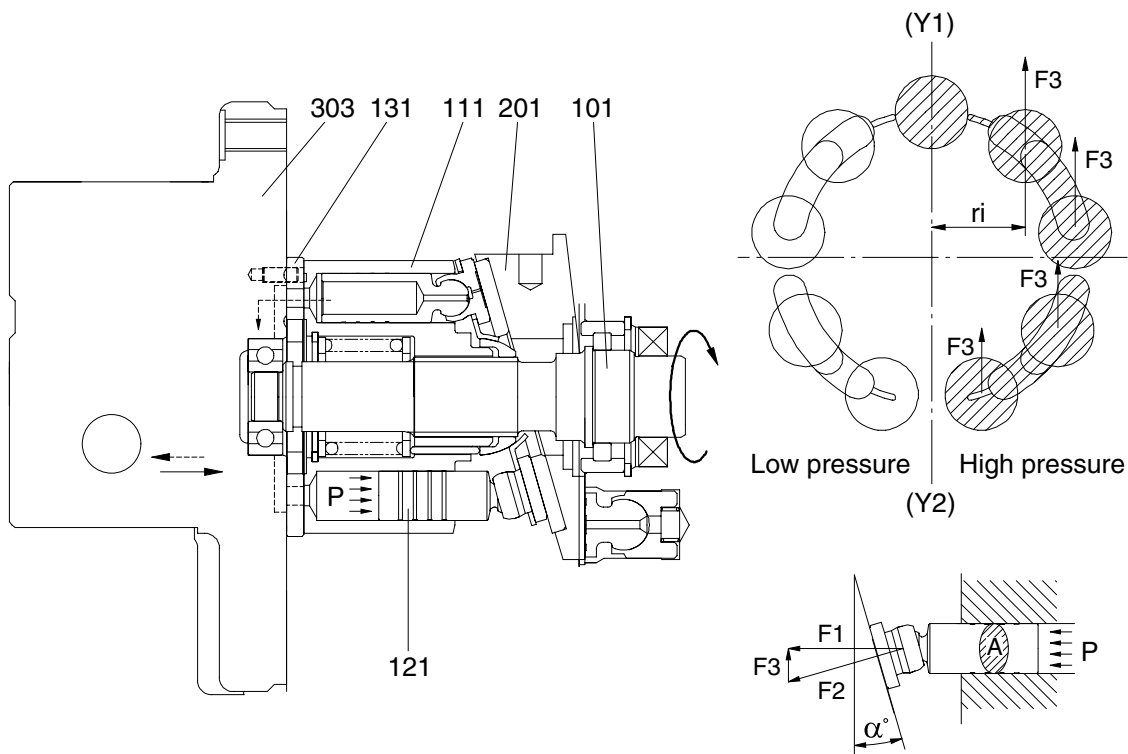

3607A2TRG02

The pressurized oil delivered from the hydraulic pump flows to valve casing(303) of the motor, passes through the brake valve mechanism, and is introduced into cylinder block(111) via valve plate(131). This oil constructively introduced only to one side of (Y1)-(Y2) connecting the upper and lower dead points of stroke of piston(121). The pressurized oil led to one side in cylinder block(111) pushes each piston(121) four or five and generates a forec [$F(\text{kgf}) = P(\text{kgf}/\text{cm}^2) \times A(\text{cm}^2)$]. This force acts on swash plate(201), and is resolves into components(F_2 and F_3) because swash plate(201) is fixed at an angle(α) with the axis of drive shaft(101). Radial component(F_3) generates respective torques($T=F_3 \times r_i$) for (Y1)-(Y2). This residual of torque [$T=S(F_3 \times r_i)$] rotates cylinder block(111) via piston(121). Since the cylinder block(111) is spline coupled with drive shaft(101). So the drive shaft(101) rotates and the torque is transmitted.

2) RELIEF VALVE

The relief valve mainly has the following two functions :

- (1) To keep the starting pressure of the hydraulic motor at a constant value and bypass to the return line excessive oil generated at the motor inlet depending upon the acceleration speed of the driven inertia.
- (2) To generate a brake pressure at the outlet during stopping of the driven inertia, and stop it forcedly.

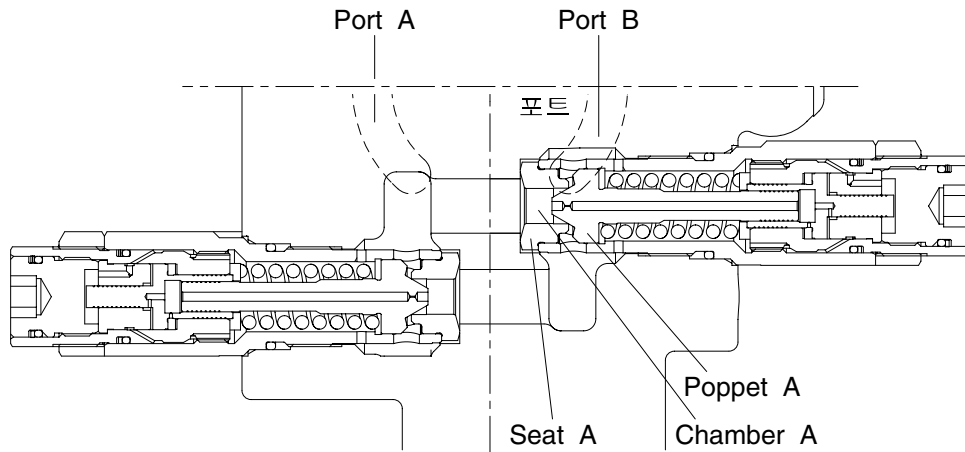

3607A2TM06

The chamber A is always connected to the port A of the motor.

When the pressure at port A increases and the force pushing poppet A is higher than the set pressure of the spring, then poppet A is pushed up from the contact surface of seat A, and oil flows from chamber A to port B.

3) NEGATIVE BRAKE

The negative brake is released applying to the brake piston(702) the pressure led through the built-in counterbalance spool sub-assembly(022).

With no pressure working, the brake force is always ensured.

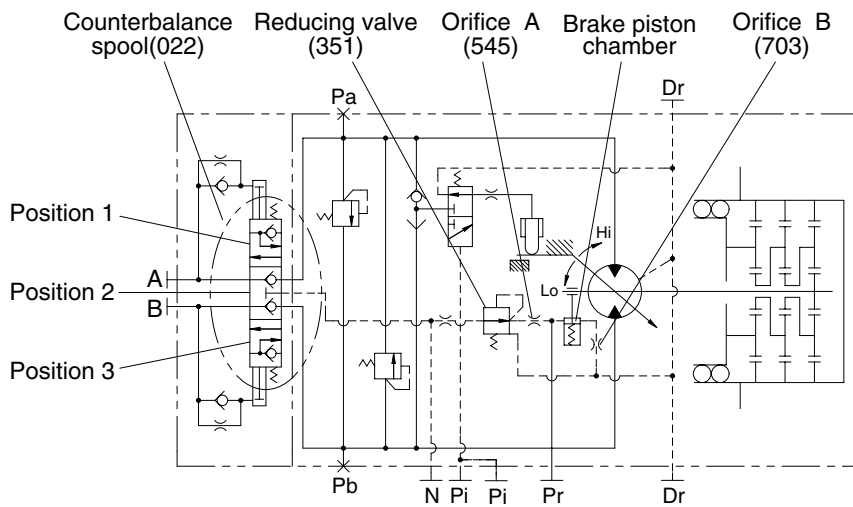
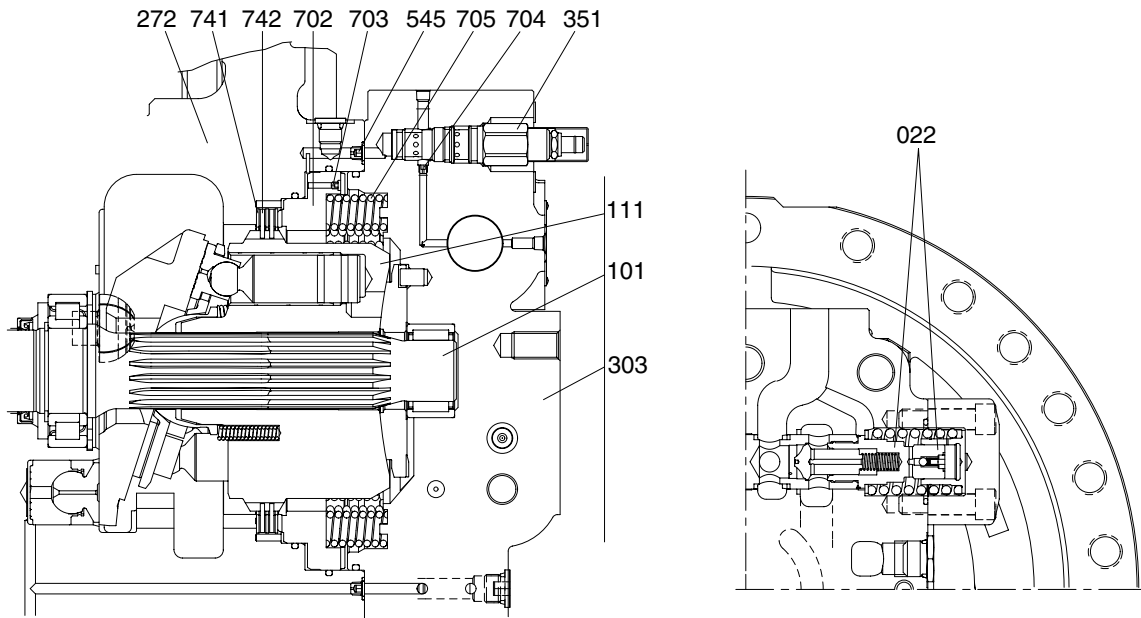

3607A2TM07

The brake force is the friction force generated on the surfaces of the friction plates(742) spline-coupled with the cylinder block(111), when their rotation is restricted by the shaft casing(272), separation plate(741), and brake piston(702).

Without pressure being applied to the brake piston, the brake piston is pushed by fourteen brake springs(705), and the friction plate and separation plate are held between the brake and shaft casing. This holding force functions as the friction force. This friction force restrains the shaft(101) spline-coupled with the cylinder block, and this function is the brake.

4) PRESSURE RELEASE VALVE (Flow control valve)

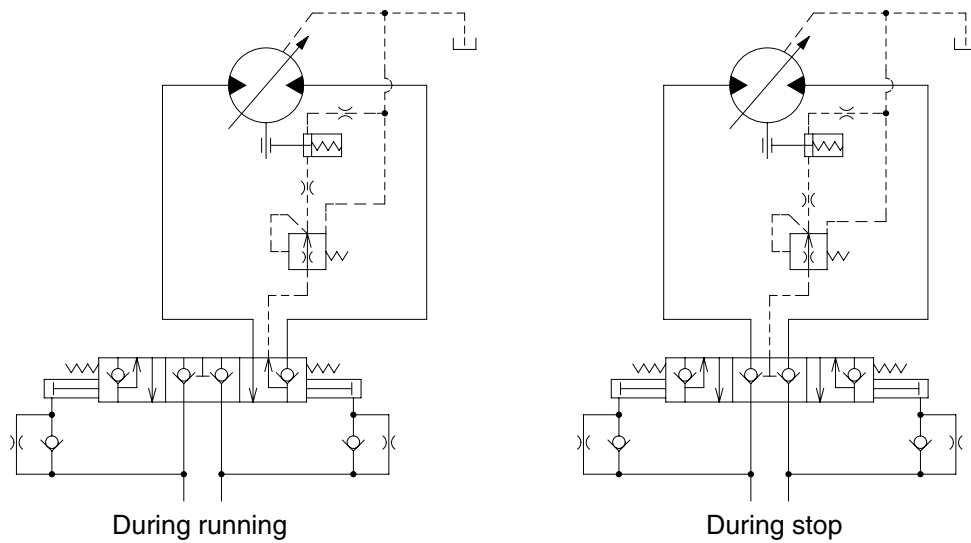

3607A2TM08

This brake is of a backpressure-insensitive type. In other words, since the counterbalance spool used be overlapped at the neutral position, the pressure release valve prevents the circuit backpressure from working into the brake chamber when the machine stops traveling and works, and so the specified brake torque is available even on a slope.

During normal traveling, the pressure coming through the counterbalance valve is applied to the brake chamber to release the break, and is also applied to the pressure release valve section.

This pressure release valve is of a constant differential pressure type, and irrespective of the working pressure, the passing flow is constant and approximately 1 to 2 l / min.

When the condition changes from traveling to stop, the counterbalance spool returns to its neutral position. The brake piston is pushed by the brake spring, and the oil in the brake chamber flow to the motor drain line via the pressure release valve. Then the brake torque is generated.

5) RELEASING METHOD OF NEGATIVE BRAKE

In releasing the negative brake without applying the brake releasing pressure, follow the procedures shown below.

Details of work	Tools
Remove two plugs(564) from the valve casing(303). (For their position, see the attached installation dimension) Tighten an M10 screw of 135mm in length into a tapped hole of the brake piston(702). Then the condition having the brake release pressure is attained and the brake is released.	Socket wrench 6mm 8mm

Note : Even with the negative brake released, the hydraulic motor will not turn. When it is difficult to generate the working pressure due to failure of the pump or so, and the whole machine is to be pulled for transportation without removing the hydraulic motor, connect pressure measurement ports A_M and B_M with a short hose or something. Then the machine can be pulled slowly.

6) COUNTERBALANCE VALVE

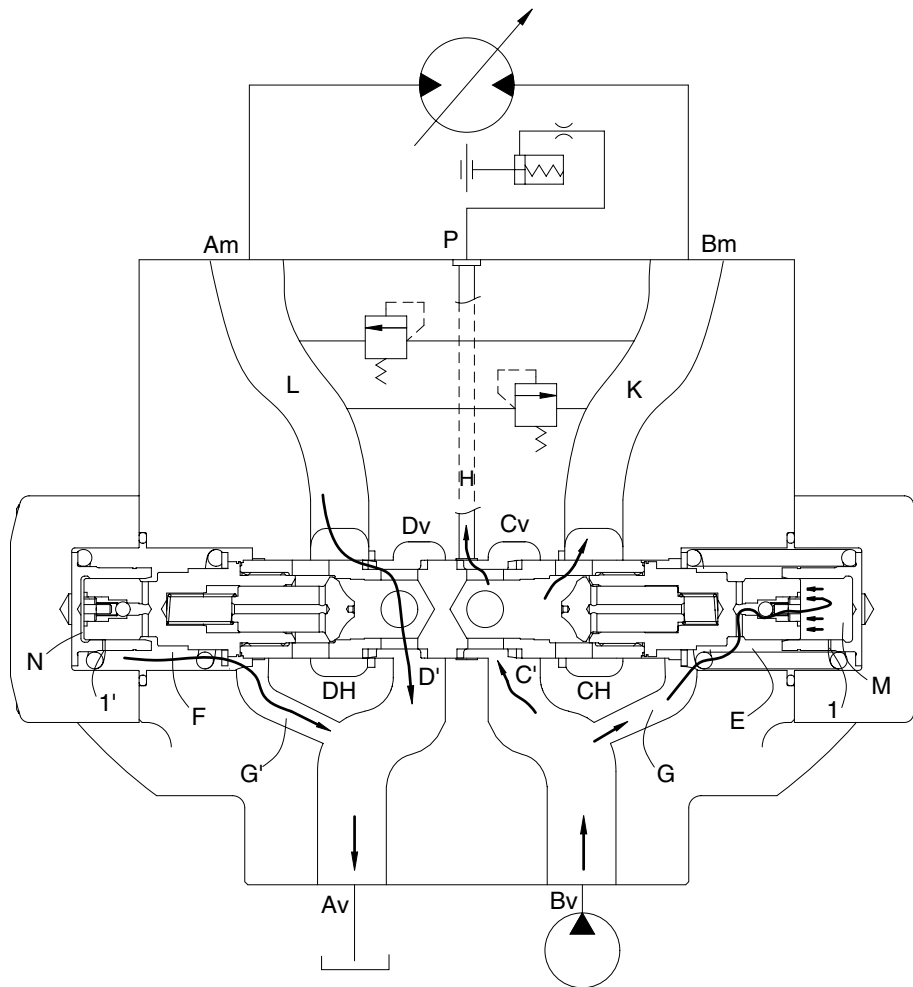

3607A2TRG03

Suppose port Bv is connected to the hydraulic pump and Port Av, to the tank. The oil supplied from the hydraulic pump passes through Bv, Cv and C' in sequence, pushes up the poppet of the check valve, passes through K to Port Bm, and is supplied to the hydraulic motor to turn it.

Therefore, the pump discharge oil pressure increases, and the pressure is led via passage G to spring room E and via the ball check valve to dumping room M. When the pressure in rooms E and M exceeds the value equivalent to the force of the spring which holds the spool at its neutral position, the spool begins to move left. Since the working oil in room N flows into room F via throttle 1' or clearance 2' and that in room F is discharged via passage G' through port Av to the tank, the spool moves left to have passage L-Dm-D'-Dv composed. In addition, passage Cv-H-P is also composed, and the pump discharge pressure in port Bv is led to port P.

Because of the throttle or clearance provided for the working oil flow from room N, this changeover motion of the spool is comparatively slow.

When the pump discharge pressure is higher, the spool movement is larger and the above opening area of the spool is larger.

When the pump discharge pressure falls, pressures in rooms E and M fall and the spool will move right due to the spring on the room F side.

Since working oil in room M flows to room E via throttle 1 and that in room E, to port Bv via passage G, the spool moves right.

When the pressure at port Bv falls down to the tank pressure, the pressure in room E also falls to the tank pressure and becomes equal to that in room F, and so the spool returns to its neutral position.

7) DISPLACEMENT CHANGEOVER SECTION

As a supporting mechanism for the swash plate(201) on which the shoes(122) slide, the pillar system is adopted to support the load with semi-cylindrical sliding bearings provided at both ends of the mechanism.

The capacity is changed by changing the tilting angle of this swash plate.

This is a mechanism that swash plate was pushed by tilting position, and the tilting angle of the swash plate is decided in two positions (Large and Small) by controlling the flows to and from these piston rooms with the displacement changeover valve section.

(1) External pilot pressure : $P_i = 0$ ————— Large displacement

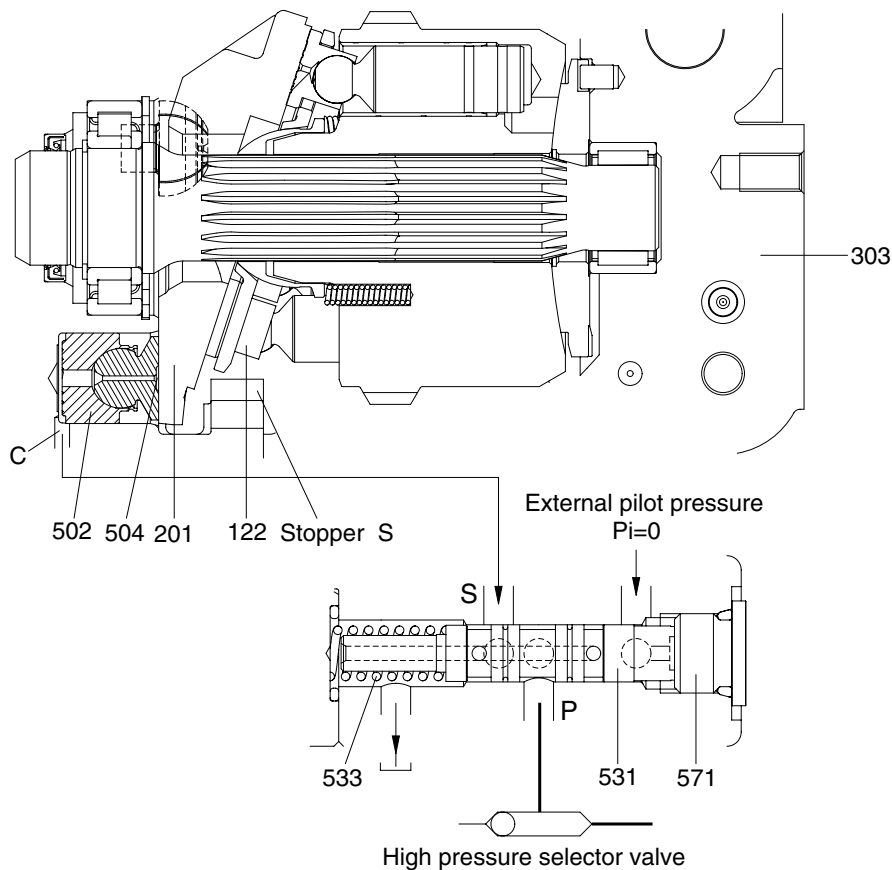

3607A2TM04

By means of the built-in high pressure selector mechanism in the valve casing(303), the high pressure oil working on the motor functions to port P of the displacement-changeover valve. This pressure becomes the servo pressure. Since the spool(531) assembled in the displacement changeover valve is pressed to plug(571) by thy spring(533), the high pressure oil at port P is enclosed.

(2) External pilot pressure : $P_i \geq 20\text{kgf/cm}^2$ ——— small displacement

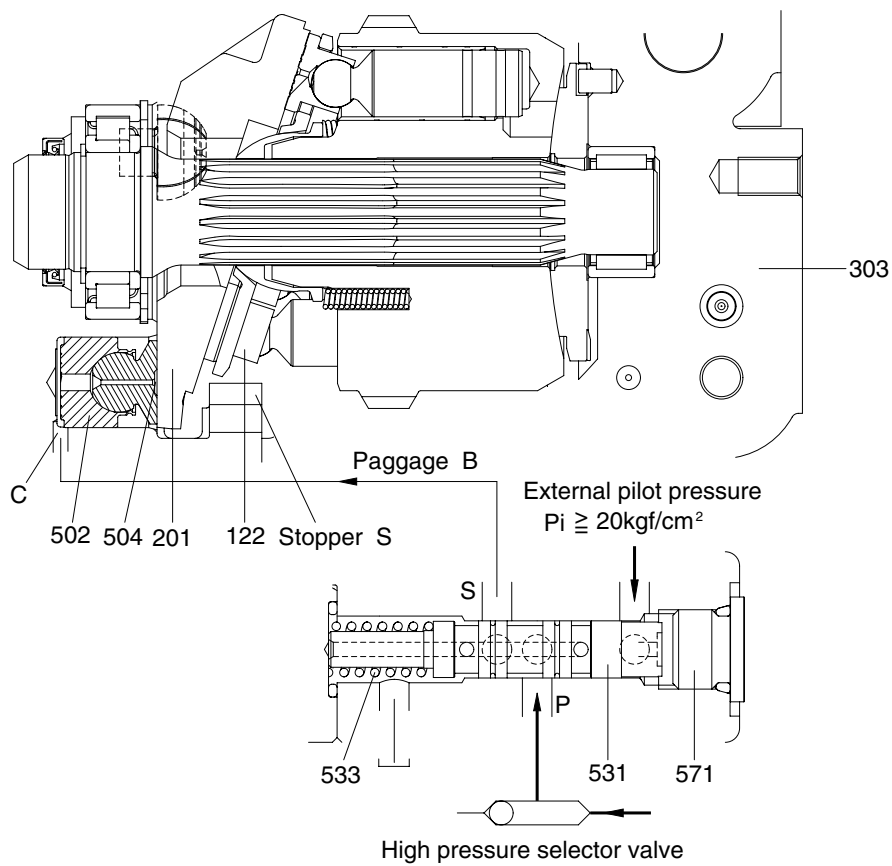

3607A2TM05

The force working on the spool(531) of the displacement-changeover valve becomes higher than that of the spring(533), and the spool moves left. The high pressure oil flows from port P of the displacement-changeover valve through port S and passage B to room C where it works. The displacement changeover piston(502) is pushed light by the high pressure oil and the swash plate moves in the arrowed direction. The swash plate moves until it touched stopper S, and then is fixed there.

8) REDUCTION GEAR

The reduction gear is composed of a three-stage planetary gear mechanism shown in the following figure. Since the sun gear is designed to have a floating mechanism, errors of the gears and carrier pin hole pitches will not affect the gears' lives heavily.

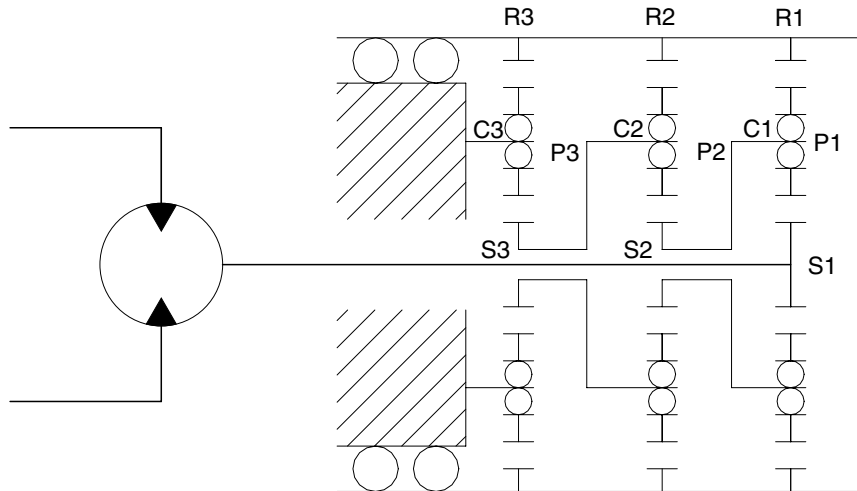

3607A2TRG04

The input rotation of the hydraulic motor is transmitted to No. 1 sun gear (S1) and this drives No. 1 planetary gears (P1). This No. 1 planetary gears (P1) drive No.1 ring gear (R1) with the same force as the meshing tangential force with No. 1 sun gear (S1), and also No. 1 carrier (C1) with the same force as the meshing reaction force. In other words, No. 1 planetary gears (P1) revolve rotating. This rotation of No. 1 carrier (C1) becomes the output of the 1st stage, and is transmitted directly to No. 2 sun gear (S2).

(No. 1 carrier is spline-coupled with No. 2 sun gear.) Similarly the revolution of No. 2 planetary gear (P2) are transmitted via No.2 carrier (C2) to No. 3 sun gear (S3). Since No. 3 carrier (C3) supporting No. 3 planetary gears (P3) are fixed, No. 3 planetary gears (P3) do not revolve, but rotates to drive No. 3 ring gear (R3).

Therefore, the rotating case is driven by the overall driving torque of No1, 2 and 3 ring gears.

This reduction ratio is expressed as shown below:

$$i = \frac{(Z_{S1} + Z_{R1}) (Z_{S2} + Z_{R2}) (Z_{S3} + Z_{R3})}{Z_{S1} \cdot Z_{S2} \cdot Z_{S3}} - 1$$

where Z : Number of teeth of each gear

The direction of rotation is reverse to that of the input shaft.