

GROUP 3 SWING DEVICE(up to #0062)

1. STRUCTURE

Swing device consists swing motor, swing reduction gear.

Swing motor include mechanical parking valve, relief valve, make up valve and time delay valve.

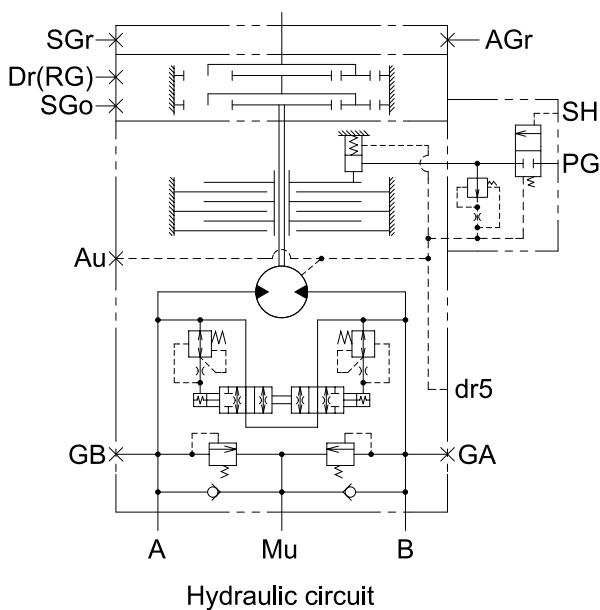
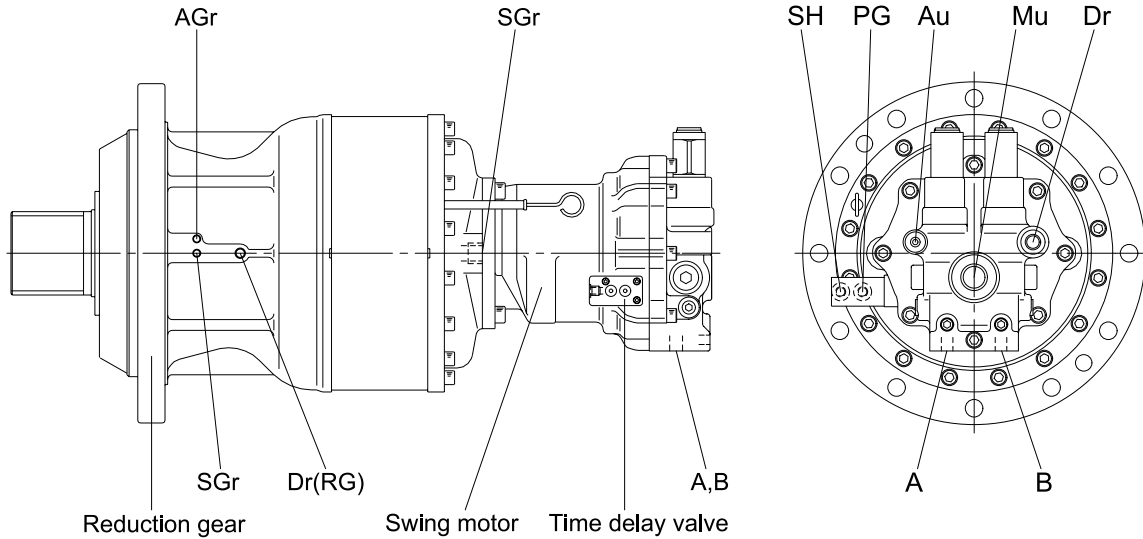

Port	Port name	Port size
A	Main port	SAE 1"
B	Main port	SAE 1"
Dr	Drain port	PF 1/2
MU	Make up port	PF 1 1/4
SH	Brake release port	PF 1/4
PG	Stand by port	PF 1/4
GA, GB	Gauge port	PF 1/4
Au	Motor air bleed port	PF 1/2
AGr	R/G air bleed port	PT 1/8
SGr	Grease filling port	PT 1/8
Dr(R/G)	Drain port	PT 3/8
SGo	Gear oil filling port	PT 3/4

36072SM01

1) SWING MOTOR

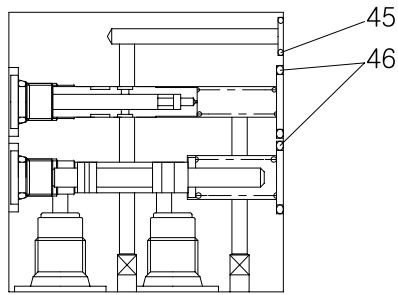
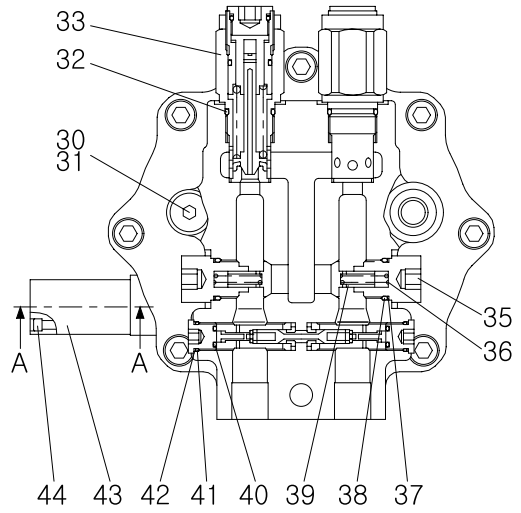
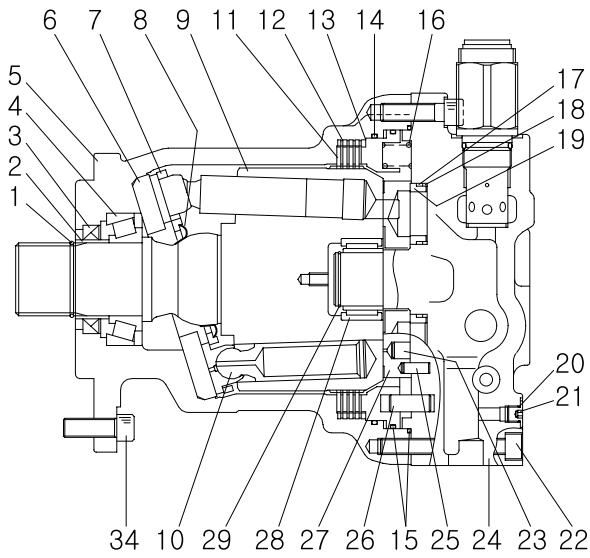

SECTION A-A

36072SM02

- | | | | | | |
|----|----------------------|----|----------------|----|-----------------------|
| 1 | Snap ring | 17 | Teflon ring | 32 | O-ring |
| 2 | Inner ring | 18 | Disk spring | 33 | Relief assembly |
| 3 | Oil seal | 19 | Bushing | 34 | Socket bolt |
| 4 | Taper roller bearing | 20 | Plug | 35 | Cap |
| 5 | Housing | 21 | O-ring | 36 | Spring |
| 6 | Cam plate | 22 | Socket bolt | 37 | Back up ring |
| 7 | Return plate | 23 | Piston | 38 | O-ring |
| 8 | Backing spring | 24 | Cover | 39 | Check |
| 9 | Cylinder assembly | 25 | Parallel pin | 40 | O-ring |
| 10 | Piston assembly | 26 | Parallel pin | 41 | Backup ring |
| 11 | Lining plate | 27 | Balance plate | 42 | Bypass valve assembly |
| 12 | Free plate | 28 | Needle bearing | 43 | Time delay valve |
| 13 | Piston | 29 | Snap ring | 44 | Socket bolt |
| 14 | O-ring | 30 | Cap | 45 | O-ring |
| 15 | O-ring | 31 | O-ring | 46 | O-ring |
| 16 | Spring | | | | |

2) REDUCTION GEAR(-#0062)

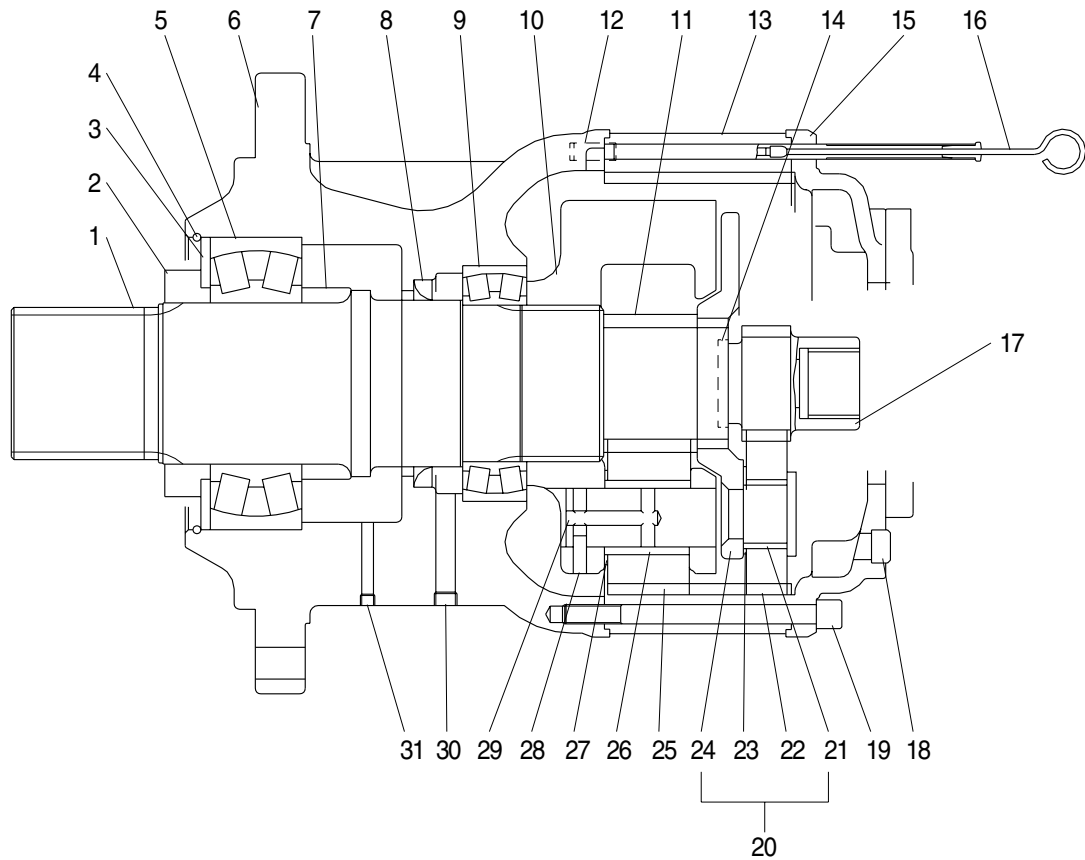

36072SM03

1	Shaft	12	Parallel pin	23	Thrust plate 1
2	Collar	13	Ring gear	24	Holder 1
3	Plate	14	Thrust plate	25	Gear 5
4	Snap ring	15	Cover	26	Bushing 2
5	Roller bearing	16	Level gauge	27	Thrust plate 2
6	Gear casing	17	Sun gear	28	Spring pin
7	Collar	18	Plug	29	Shaft 2
8	Oil seal	19	Socket bolt	30	Plug
9	Roller bearing	20	Holder 1 assembly	31	Plug
10	Holder 2	21	Shaft 1		
11	Gear 4	22	Gear 2		

2. FUNCTION

1) ROTARY PART

When high pressurized oil enters a cylinder through port(a), which is the inlet of balance plate(1), hydraulic pressure acting on the piston causes axial force F. The pressure force F works via the piston(2) upon the return plate(3) which acts upon the swash plate(4) via an hydrostatic bearing. Force F1 perpendicular to swash plate(4) and force F2 perpendicular to cylinder center.

Being transferred to the cylinder block(5) through piston, force F2 causes rotational moment at surroundings of cylinder.

Since cylinder block has 9 equidistantly arrayed pistons, rotational torque is transmitted to cylinder shaft in order by several pistons connected to the inlet port of high pressurized oil. When the direction of oil flow is reversed, rotational direction of cylinder is also reversed. Output torque is given by the equation.

$$T = \frac{p \times q}{2}, \quad q = Z \cdot A \cdot \text{PCD} \cdot \tan \alpha, \quad F_1 = \frac{F}{\cos \alpha}, \quad F_2 = F \tan \alpha, \quad S = \text{PCD} \times \tan \alpha$$

Where p : Effective difference of pressure(kgf/cm²)

q : Displacement(cc/rev)

T : Output torque(kgf · cm)

Z : Piston number

A : Piston area(cm²)

α : Tilting angle of swash plate(degree)

S : Piston stroke(cm)

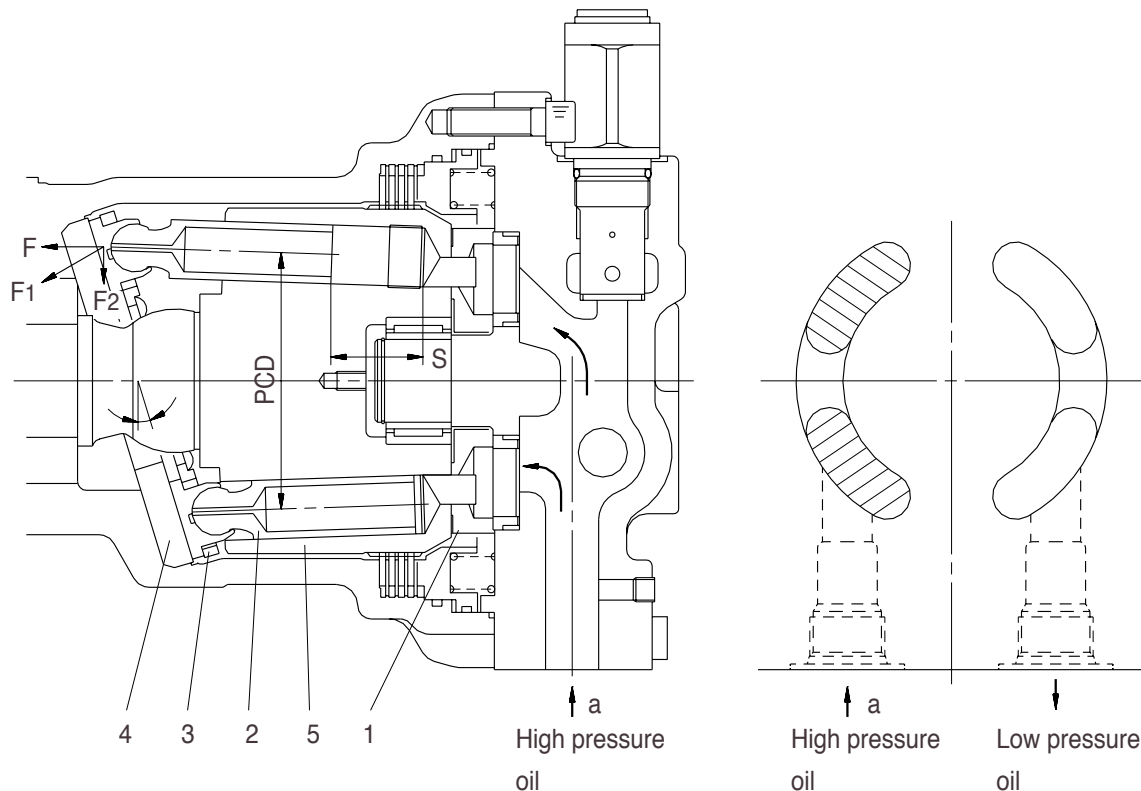

36072SM04

2) MAKE UP VALVE

In the system using this type of motor, there is no counter balance functioning valve and there happens the case of revolution exceeding hydraulic supply of motor. To prevent the cavitation caused by insufficient oil flow there is a make up valve to fill up the oil insufficiency.

A make up valve is provided immediately before the port leading to the hydraulic oil tank to secure feed pressure required when the hydraulic motor makes a pumping action. The boost pressure acts on the hydraulic motor's feed port via the make up valve.

Pressurized oil into the port B, the motor rotate counterclockwise.

If the plunger of MCV moves neutral position, the drain oil from Mu port run into motor via right make up valve, which prevent the cavitation of motor.

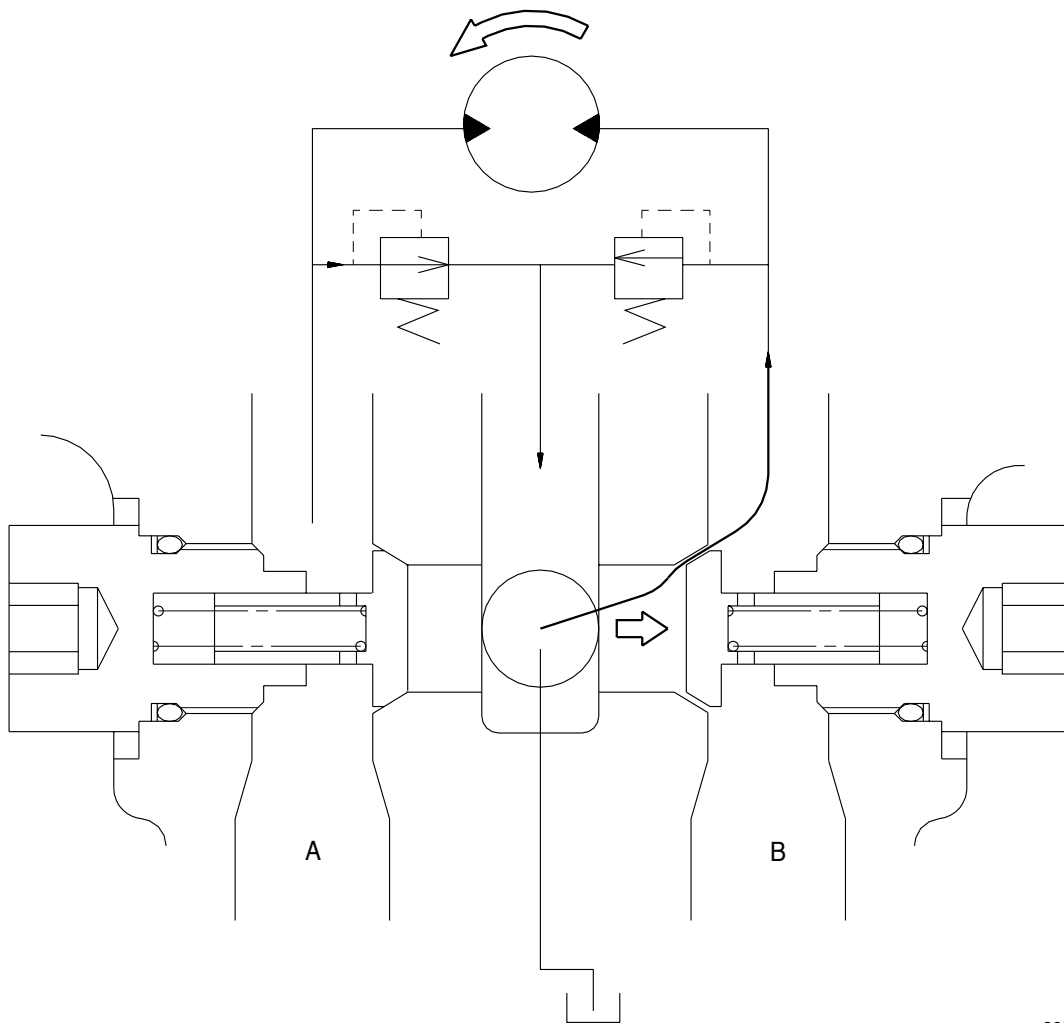

36072SM05

3) RELIEF VALVE

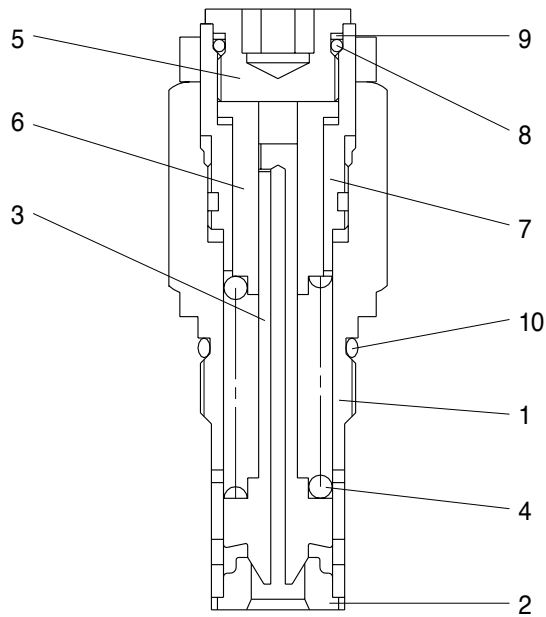

- 1 Body
- 2 Seat
- 3 Plunger
- 4 Spring
- 5 Adjusting screw
- 6 Piston
- 7 Sleeve
- 8 O-ring
- 9 Back up ring
- 10 O-ring

36072SM06

(1) Construction of relief valve

The valve casing contains two cartridge type relief valves that stop the regular and reverse rotations of the hydraulic motor. The relief valves relieve high pressure at start or at stop of swing motion and can control the relief pressure in two steps, high and low, in order to insure smooth operation.

(2) Function of relief valve

Figure illustrates how the pressure acting on the relief valve is related to its rising process. Here is given the function, referring to the figure following page.

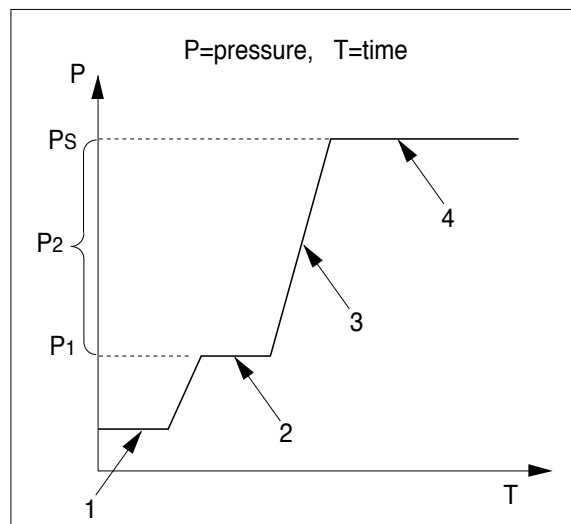

Ports (P, R) at tank pressure.

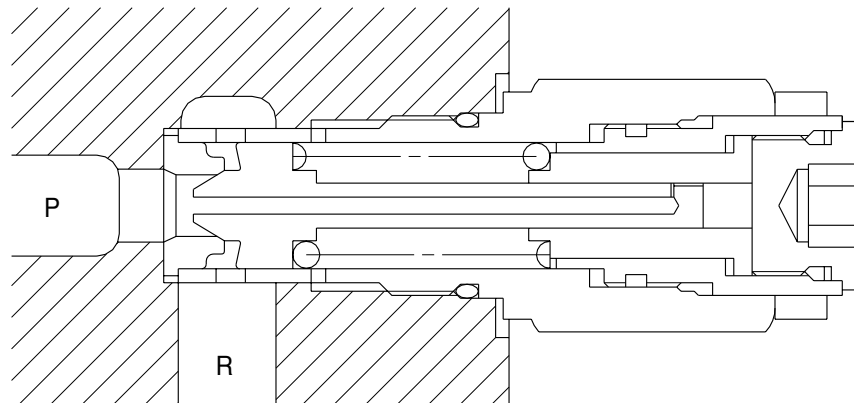

36072SM07

When hydraulic oil pressure ($P \times A_1$) reaches the preset force (F_{SP}) of spring (4), the plunger (3) moves to the right as shown.

$$P_1 \times A_1 = F_{SP} + P_g \times A_2$$

$$P_1 = \frac{F_{SP} + P_g \times A_2}{A_1}$$

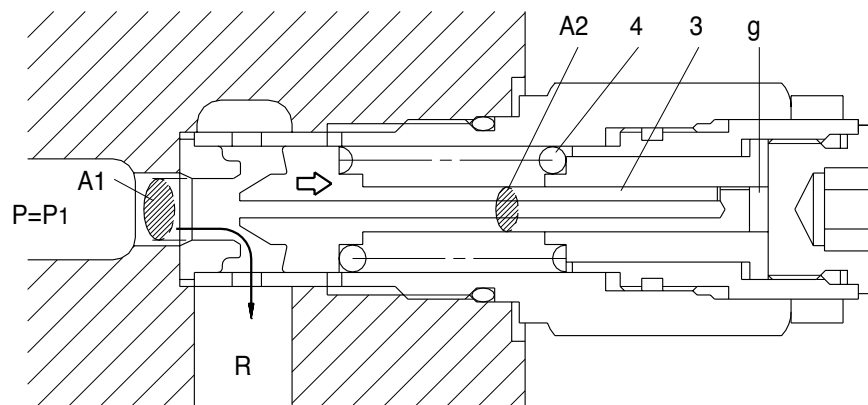

36072SM08

The oil flow chamber g via orifice m and n. When the pressure chamber g reaches the preset force (F_{SP}) of spring (4), the piston (6) moves left and stop the piston (6) hits the bottom of sleeve (7).

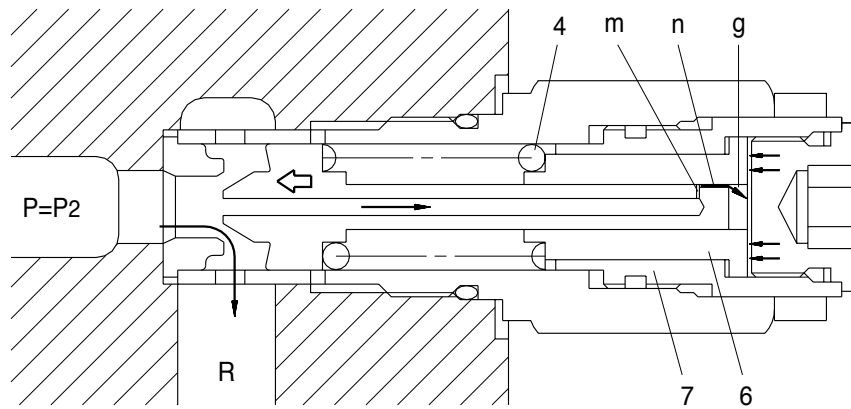

36072SM09

When piston (6) hits the end of sleeve (7), it stops moving to the left any further. As the result, the pressure in chamber (g) equals (P_S).

$$P_S \times A_1 = F_{SP} + P_S \times A_2$$

$$P_S = \frac{F_{SP}}{A_1 - A_2}$$

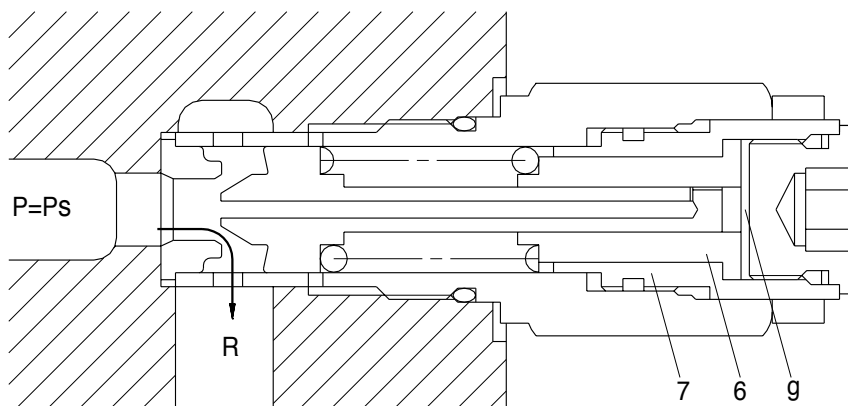

36072SM10

4) BRAKE SYSTEM

(1) Control valve swing brake system

This is the brake system to stop the swing motion of the excavator for during operation.

In this system, the hydraulic circuit is throttled by the swing control valve, and the resistance created by this throttling works as a brake force to slow down the swing motion.

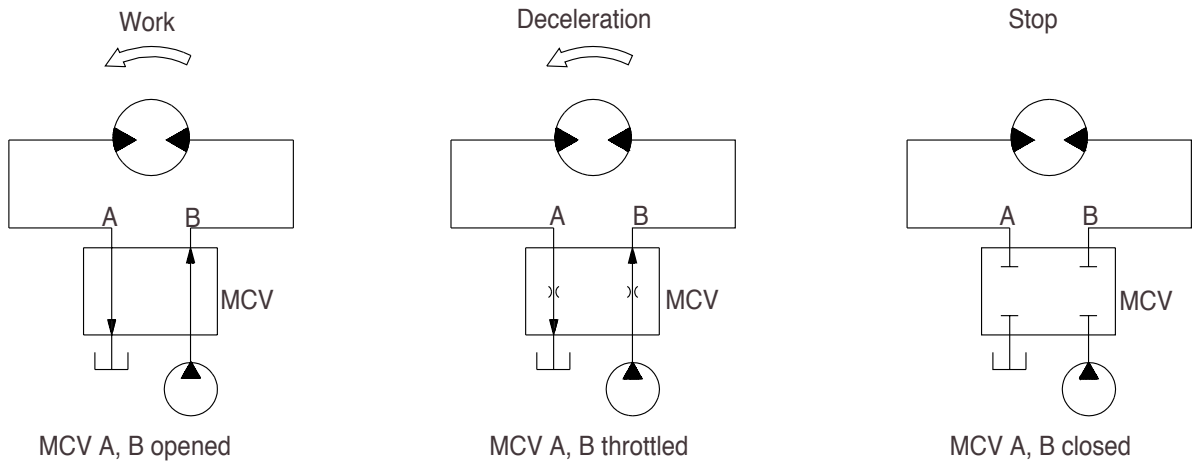

R130SM05

(2) Mechanical swing parking brake system

The mechanical swing parking brake system is installed to prevent the upper structure from swinging downhill because of its own weight when the excavator is parked on a slope since it completely eliminates the hydraulic drift of swing motion while the excavator is on a slope, work can be done more easily and safely.

Brake assembly

Circumferential rotation of separate plate(12) is constrained by the groove located at housing (5). When housing is pressed down by brake spring(16) through friction plate(11), separate plate(12) and brake piston(13), friction force occurs there.

Cylinder(9) is constrained by this friction force and brake acts, while brake releases when hydraulic force exceeds spring force.

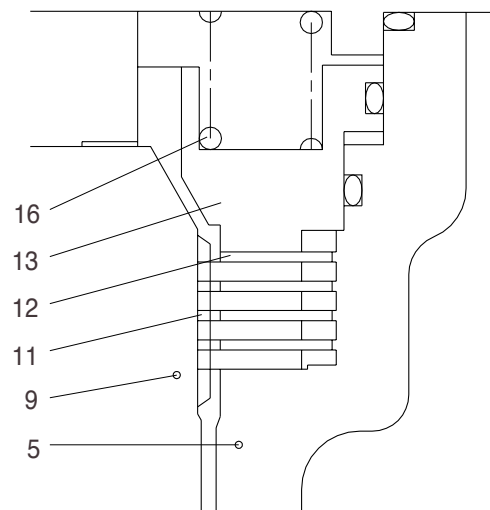

36072SM11

5	Housing	12	Separate plate
9	Cylinder	13	Brake piston
11	Friction plate	16	Brake spring

② Operating principle

a. When one of the RCV lever (1) is set to the operation position, the each spool is shifted to left or right and the pilot oil flow is blocked. Then the pilot oil go to SH of the time delay valve (3).

This pressure moves spool (5) to the leftward against the force of the spring(8), so pilot pump charged oil (P3) goes to the chamber G through port PG.

This pressure is applied to move the piston (6) to the upward against the force of the spring (9). Thus, it releases the brake force.

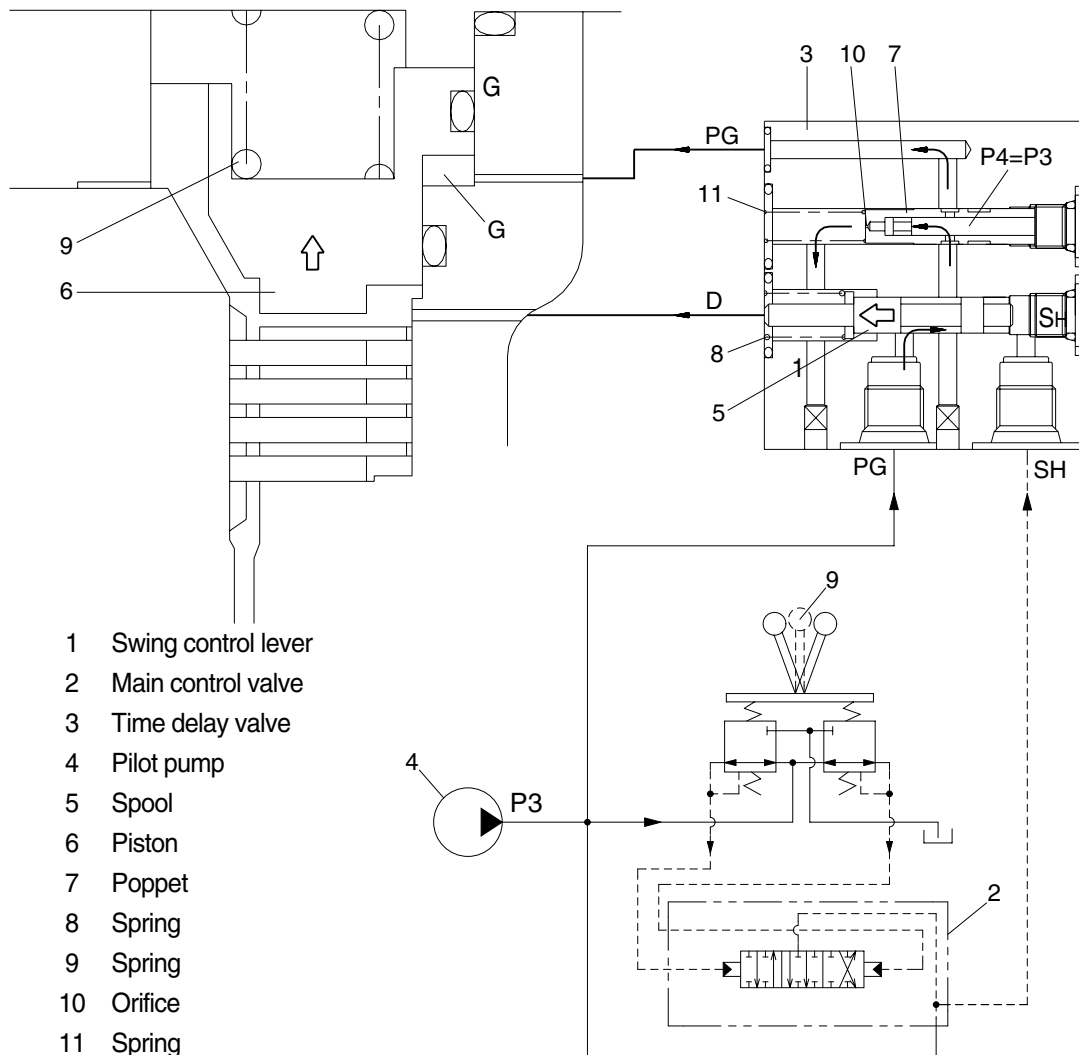

- 1 Swing control lever
- 2 Main control valve
- 3 Time delay valve
- 4 Pilot pump
- 5 Spool
- 6 Piston
- 7 Poppet
- 8 Spring
- 9 Spring
- 10 Orifice
- 11 Spring

36072SM12

1) SWING MOTOR

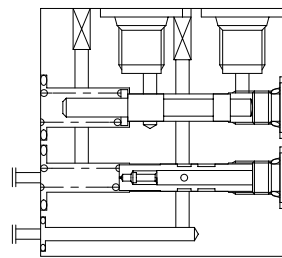
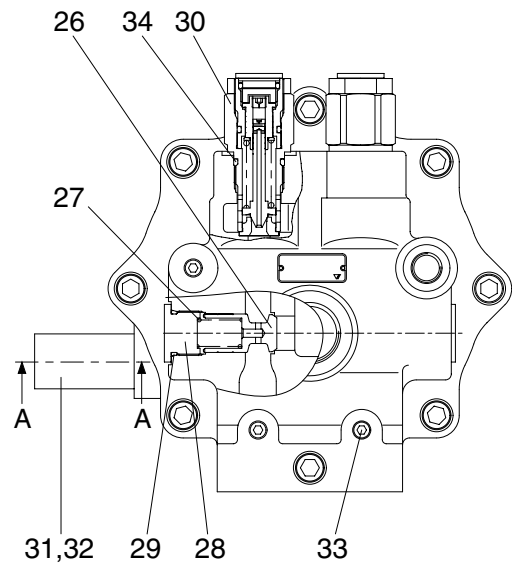
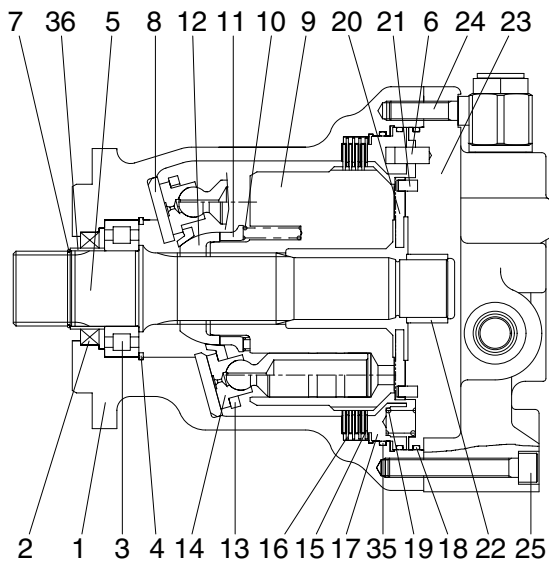

SECTION A-A

3607A2SM02

1	Body	13	Set plate	25	Wrench bolt
2	Oil seal	14	Piston assy	26	Poppet
3	Roller bearing	15	Friction plate	27	Spring
4	Snap ring	16	Plate	28	Plug
5	Shaft	17	Brake piston	29	O-ring
6	Pin	18	O-ring	30	Relief valve assy
7	Stop ring	19	Spring	31	Time delay valve
8	Shoe plate	20	Valve plate	32	Wrench bolt
9	Cylinder block	21	Pin	33	Plug
10	Spring	22	Needle bearing	34	O-ring
11	Ball guide seat	23	Rear cover	35	O-ring
12	Ball guide	24	Wrench bolt	36	Bushing

2) REDUCTION GEAR

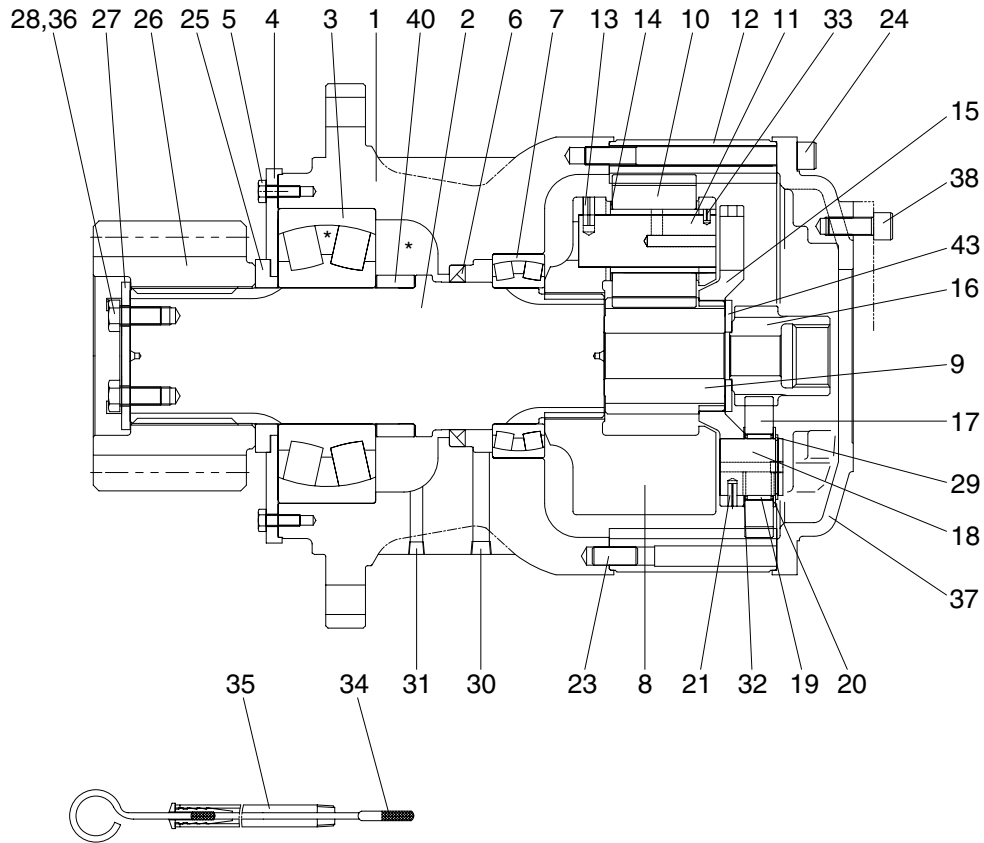

3607A2SM03

1	Casing	15	Carrier 1	29	Stop ring
2	Drive shaft	16	Sun gear 1	30	Plug
3	Roller bearing	17	Planetary gear 1	31	Plug
4	Cover plate	18	Pin 1	32	Side plate 1
5	Hex bolt	19	Needle cage	33	Spring pin
6	Oil seal	20	Side plate 2	34	Gauge bar
7	Roller bearing	21	Spring pin	35	Gauge pipe
8	Carrier 2	22	Ring gear	36	Lock washer
9	Sun gear 2	23	Knock pin	37	Cover
10	Planetary gear 2	24	Socket bolt	38	Socket bolt
11	Pin 2	25	Spacer	39	Socket plug
12	Bushing 2	26	Pinion gear	40	Ring spacer
13	Spring pin	27	Lock plate	42	Air breather assy
14	Washer	28	Hex bolt	43	Thrust ring

2. FUNCTION

1) ROTARY PART

When high pressurized oil enters a cylinder through port(a), which is the inlet of balance plate(1), hydraulic pressure acting on the piston causes axial force F. The pressure force F works via the piston(2) upon the return plate(3) which acts upon the swash plate(4) via an hydrostatic bearing. Force F1 perpendicular to swash plate(4) and force F2 perpendicular to cylinder center.

Being transferred to the cylinder block(5) through piston, force F2 causes rotational moment at surroundings of cylinder.

Since cylinder block has 9 equidistantly arrayed pistons, rotational torque is transmitted to cylinder shaft in order by several pistons connected to the inlet port of high pressurized oil. When the direction of oil flow is reversed, rotational direction of cylinder is also reversed. Output torque is given by the equation.

$$T = \frac{p \times q}{2\pi} , q = Z \cdot A \cdot \text{PCD} \cdot \tan\theta , F_1 = \frac{F}{\cos\theta} , F_2 = F \tan\theta , S = \text{PCD} \times \tan\theta$$

Where p : Effective difference of pressure(kgf/cm²)

q : Displacement(cc/rev)

T : Output torque(kgf · cm)

Z : Piston number

A : Piston area(cm²)

θ : Tilting angle of swash plate(degree)

S : Piston stroke(cm)

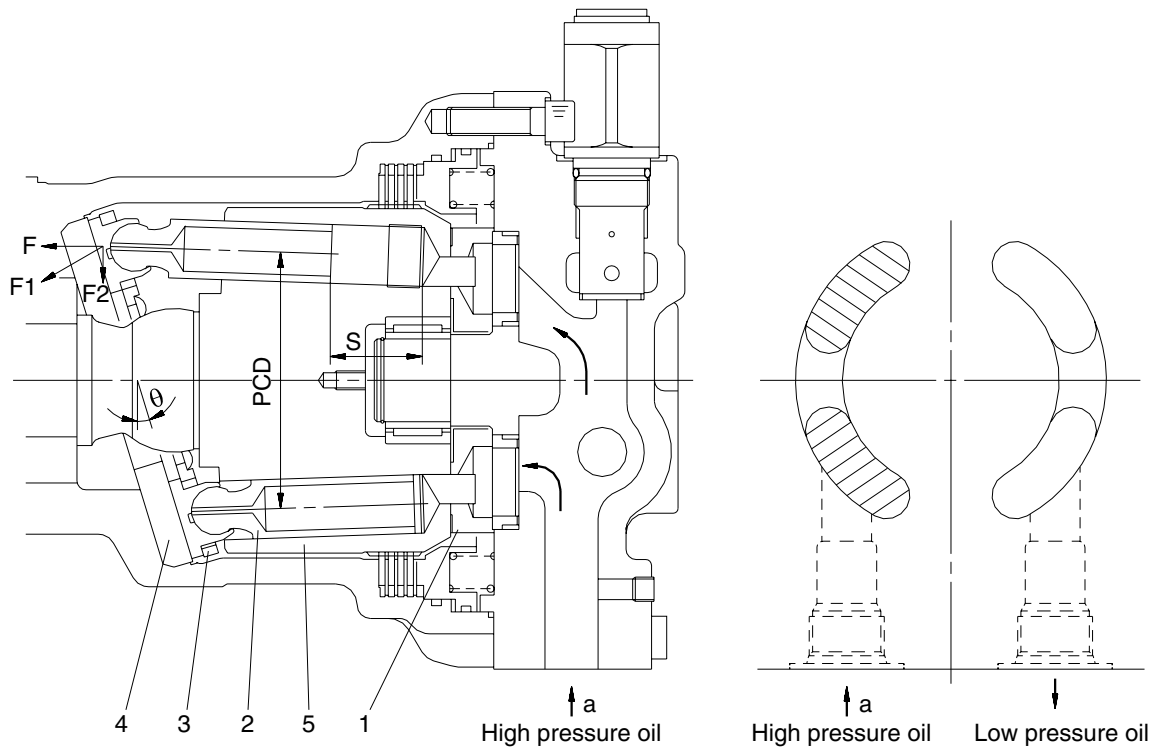

36072SM04

2) MAKE UP VALVE

In the system using this type of motor, there is no counter balance functioning valve and there happens the case of revolution exceeding hydraulic supply of motor. To prevent the cavitation caused by insufficient oil flow there is a make up valve to fill up the oil insufficiency.

A make up valve is provided immediately before the port leading to the hydraulic oil tank to secure feed pressure required when the hydraulic motor makes a pumping action. The boost pressure acts on the hydraulic motor's feed port via the make up valve.

Pressurized oil into the port B, the motor rotate counterclockwise.

If the plunger of MCV moves neutral position, the drain oil from Mu port run into motor via right make up valve, which prevent the cavitation of motor.

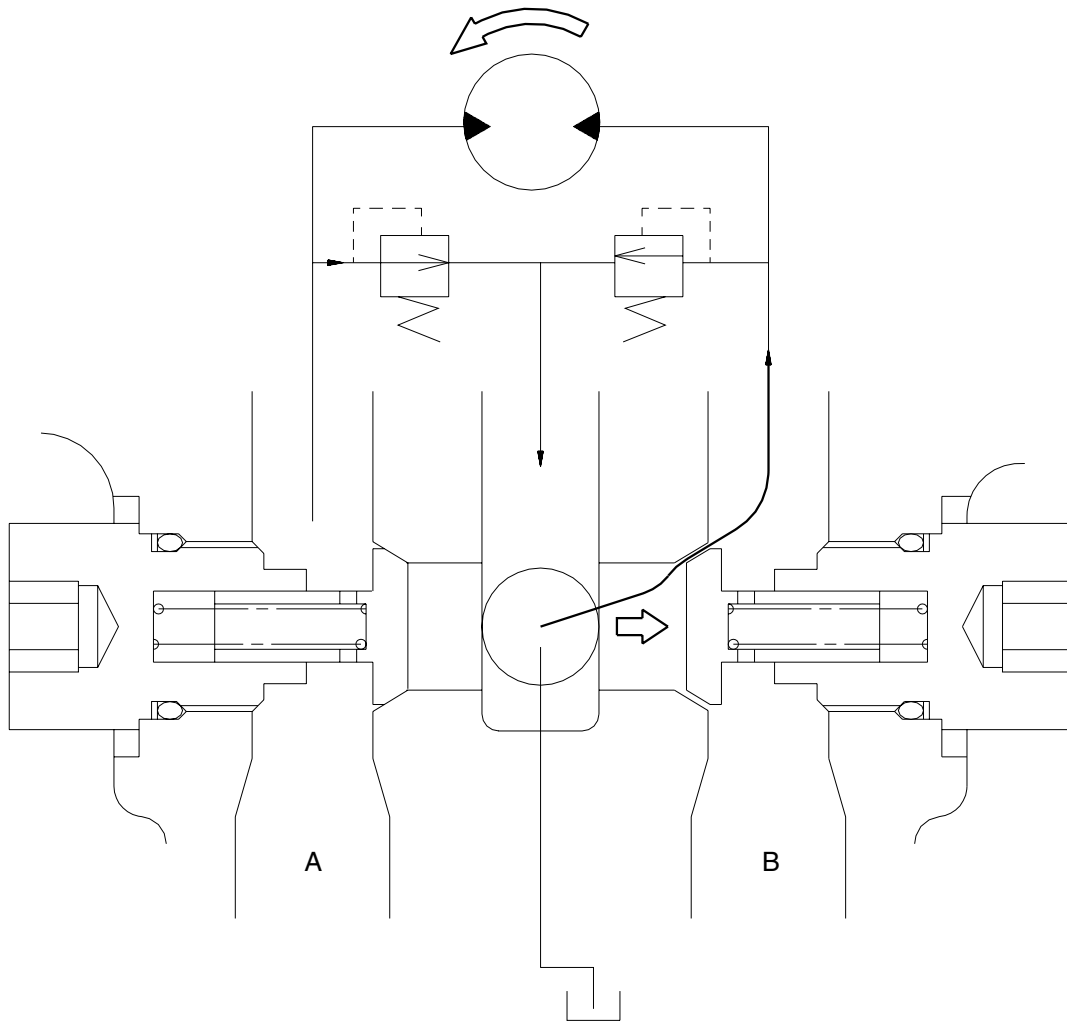

36072SM05

3) RELIEF VALVE

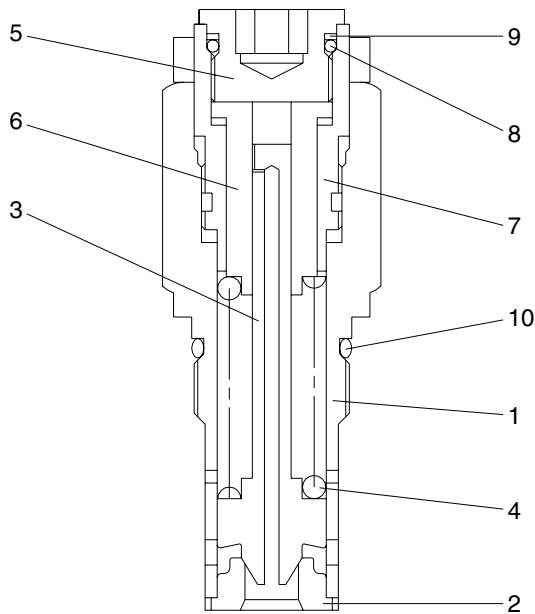

- 1 Body
- 2 Seat
- 3 Plunger
- 4 Spring
- 5 Adjusting screw
- 6 Piston
- 7 Sleeve
- 8 O-ring
- 9 Back up ring
- 10 O-ring

36072SM06

(1) Construction of relief valve

The valve casing contains two cartridge type relief valves that stop the regular and reverse rotations of the hydraulic motor. The relief valves relieve high pressure at start or at stop of swing motion and can control the relief pressure in two steps, high and low, in order to insure smooth operation.

(2) Function of relief valve

Figure illustrates how the pressure acting on the relief valve is related to its rising process. Here is given the function, referring to the figure following page.

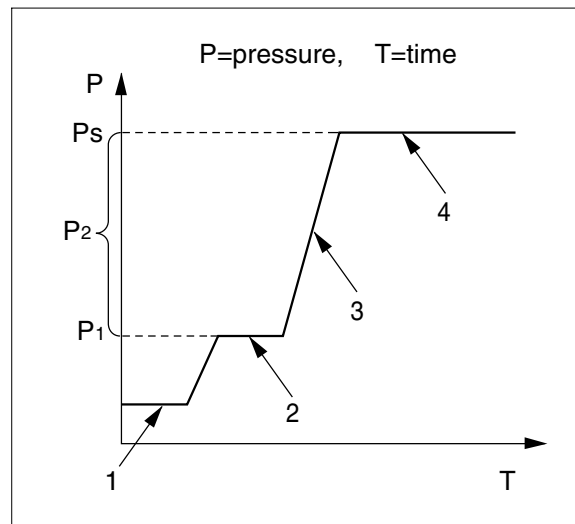

2-51(2) [360-7]

① Ports (P, R) at tank pressure.

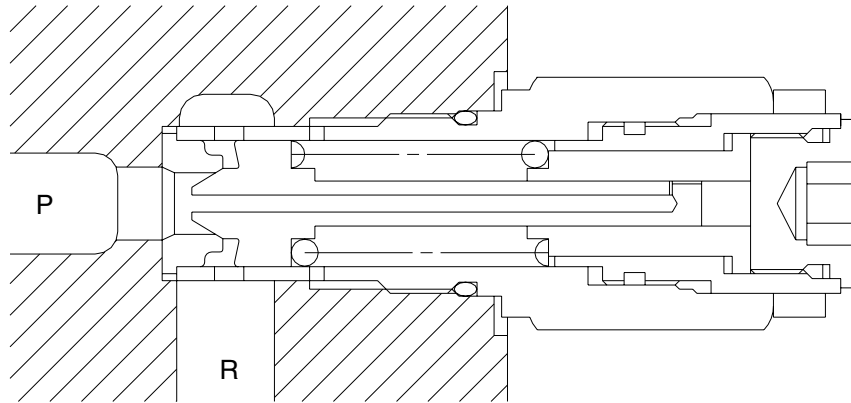

36072SM07

② When hydraulic oil pressure ($P \times A_1$) reaches the preset force (F_{SP}) of spring (4), the plunger (3) moves to the right as shown.

$$P_1 \times A_1 = F_{SP} + P_g \times A_2$$

$$P_1 = \frac{F_{SP} + P_g \times A_2}{A_1}$$

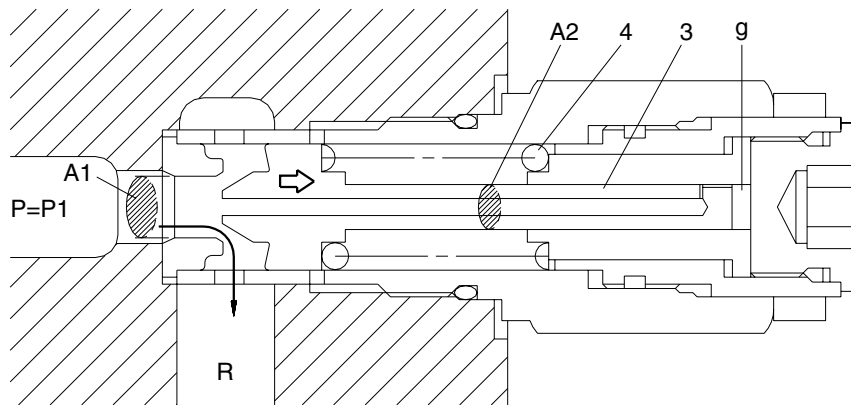

36072SM08

- ③ The oil flow chamber g via orifice m and n. When the pressure chamber g reaches the preset force(F_{sp}) of spring(4), the piston(6) moves left and stop the piston(6) hits the bottom of sleeve(7).

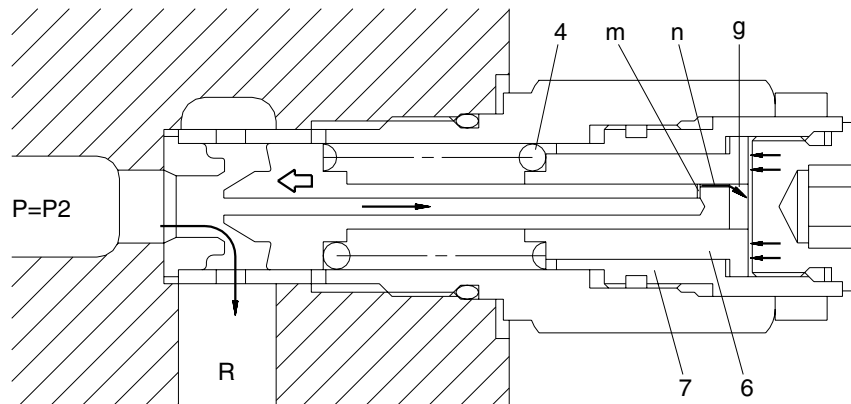

36072SM09

- ④ When piston(6) hits the end of sleeve(7), it stops moving to the left any further. As the result, the pressure in chamber(g) equals (P_s).

$$P_s \times A_1 = F_{sp} + P_s \times A_2$$

$$P_s = \frac{F_{sp}}{A_1 - A_2}$$

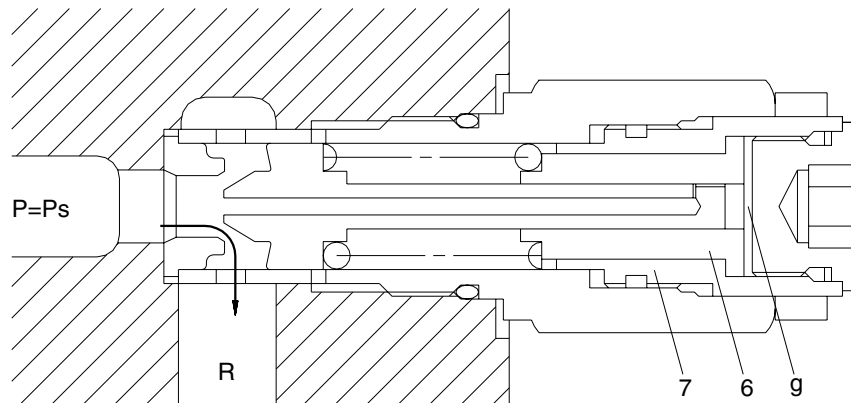

36072SM10

4) BRAKE SYSTEM

(1) Control valve swing brake system

This is the brake system to stop the swing motion of the excavator for during operation.

In this system, the hydraulic circuit is throttled by the swing control valve, and the resistance created by this throttling works as a brake force to slow down the swing motion.

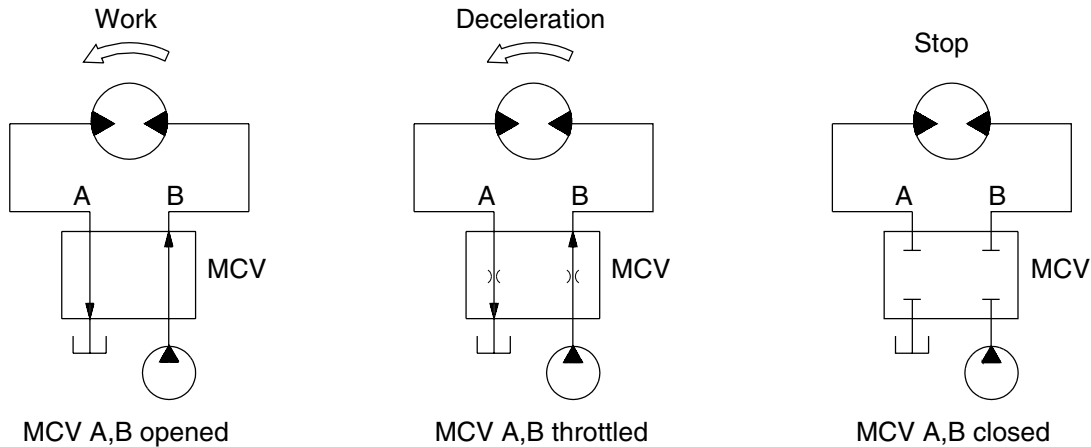

R130SM05

(2) Mechanical swing parking brake system

The mechanical swing parking brake system is installed to prevent the upper structure from swinging downhill because of its own weight when the excavator is parked on a slope since it completely eliminates the hydraulic drift of swing motion while the excavator is on a slope, work can be done more easily and safely.

① Brake assembly

Circumferential rotation of separate plate(12) is constrained by the groove located at housing (5). When housing is pressed down by brake spring(16) through friction plate(11), separate plate(12) and brake piston(13), friction force occurs there.

Cylinder(9) is constrained by this friction force and brake acts, while brake releases when hydraulic force exceeds spring force.

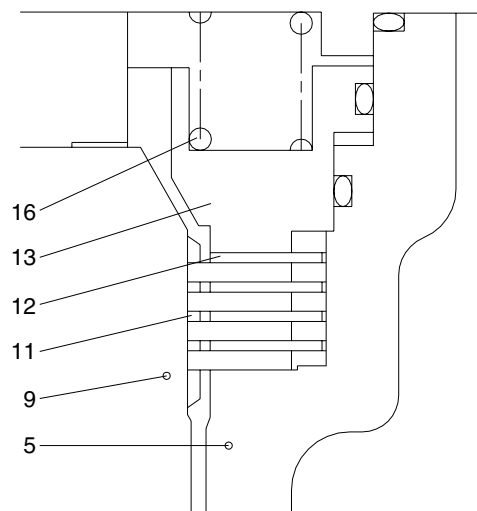

36072SM11

5	Housing	12	Separate plate
9	Cylinder	13	Brake piston
11	Friction plate	16	Brake spring

② Operating principle

a. When one of the RCV lever (1) is set to the operation position, the each spool is shifted to left or right and the pilot oil flow is blocked. Then the pilot oil go to SH of the time delay valve (3).

This pressure moves spool (5) to the leftward against the force of the spring(8), so pilot pump charged oil (P3) goes to the chamber G through port PG.

This pressure is applied to move the piston (6) to the upward against the force of the spring (9). Thus, it releases the brake force.

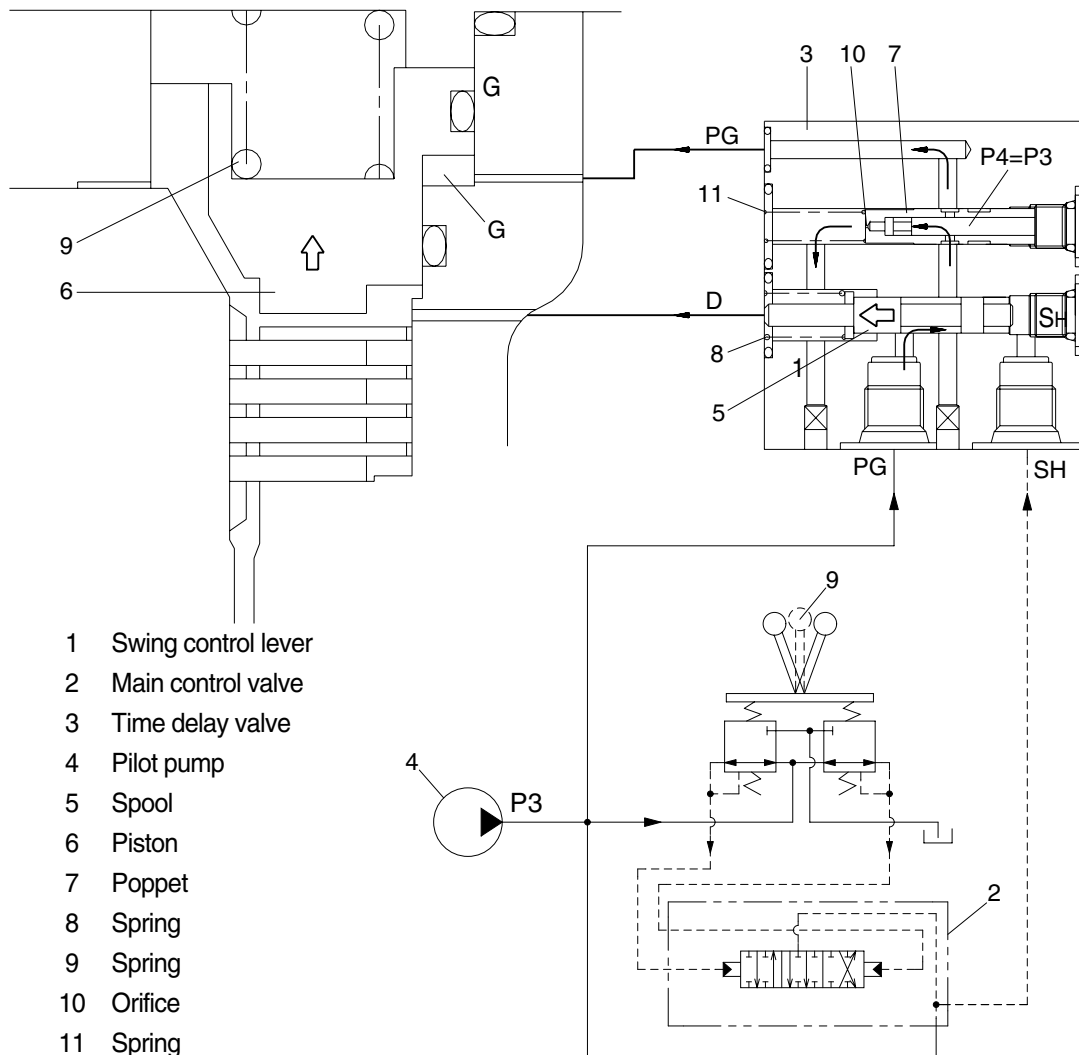

36072SM12

- b. When all of the RCV lever (1) are set the neutral position, the spool (5) returns to right.
 Then, the piston (6) is moved lower by spring force and the return oil from the chamber G flows back to tank port.
 At this time, the brake works.

