

## 2. FUNCTION

### 1) HYDRAULIC CIRCUIT

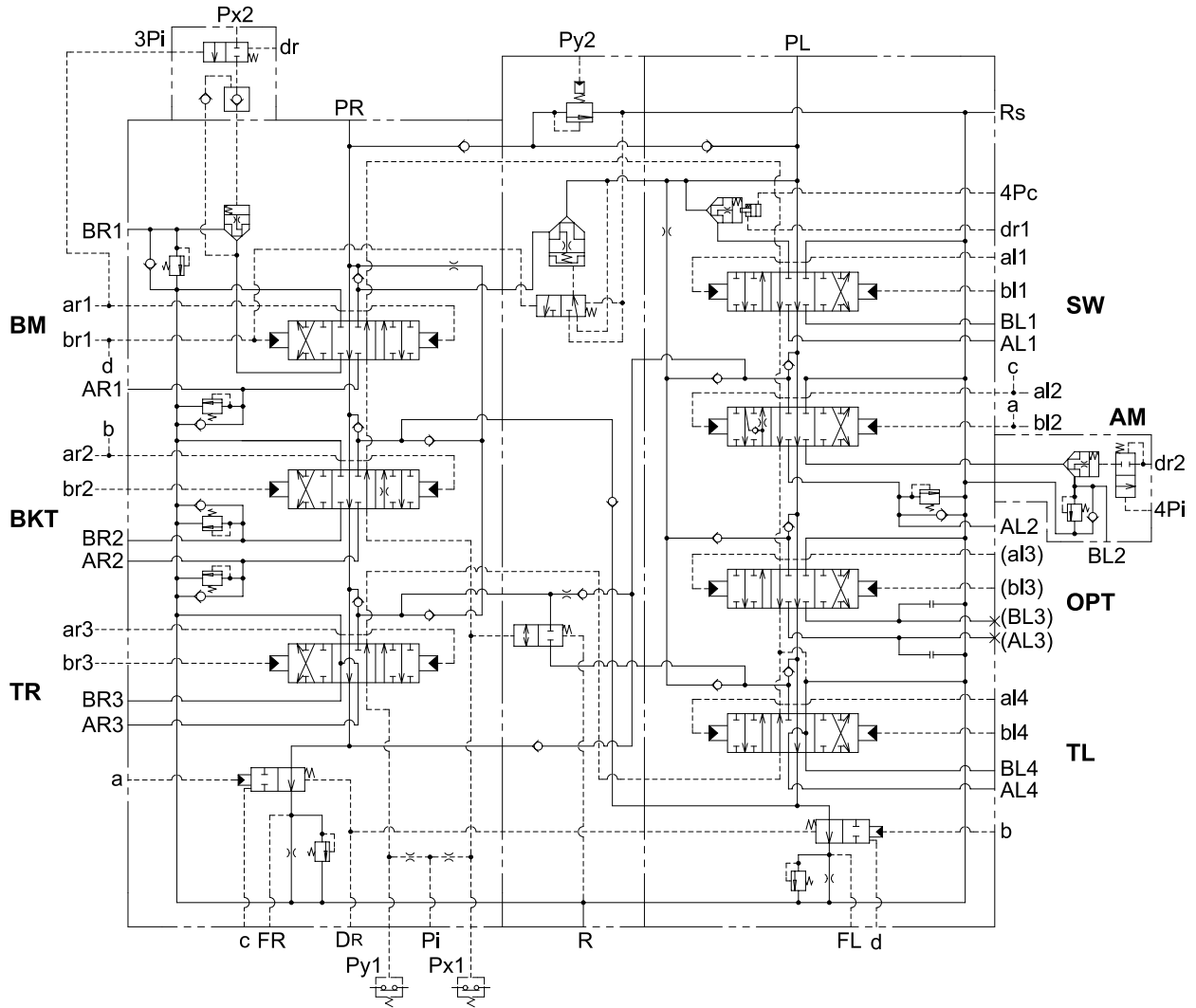

36072MC04

## GROUP 2 MAIN CONTROL VALVE

### 1. STRUCTURE

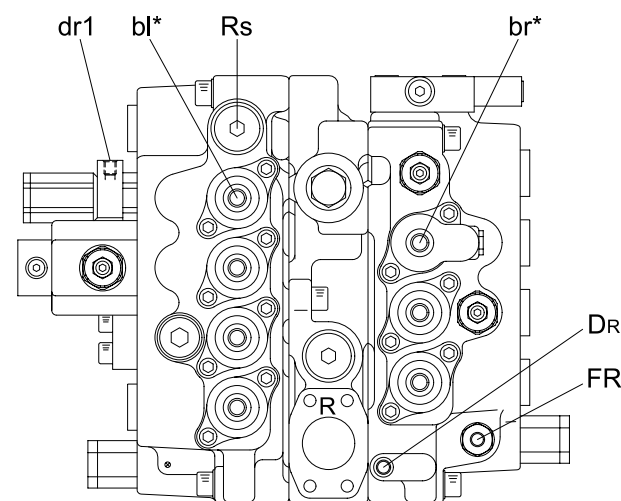
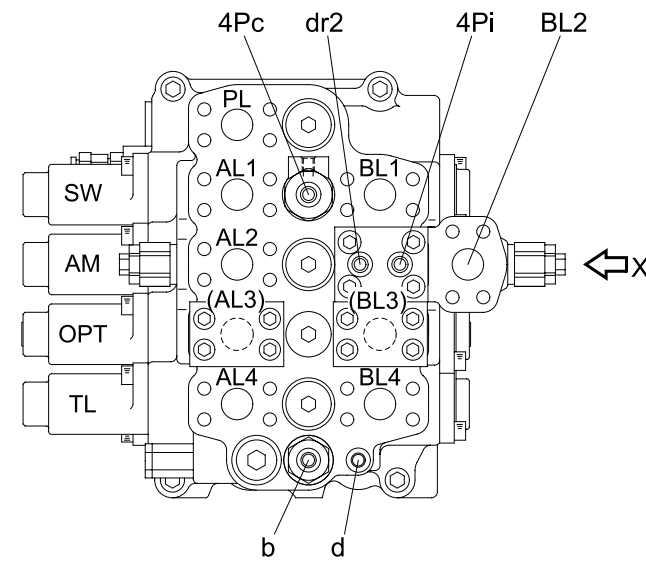
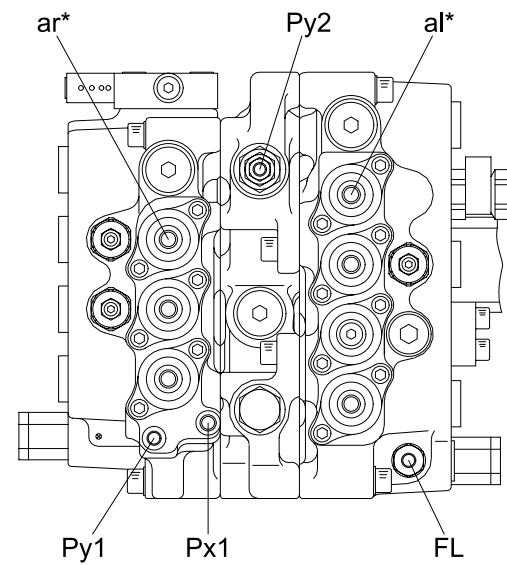
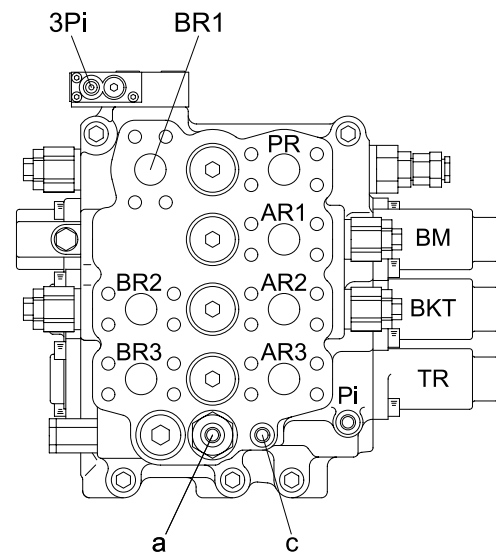
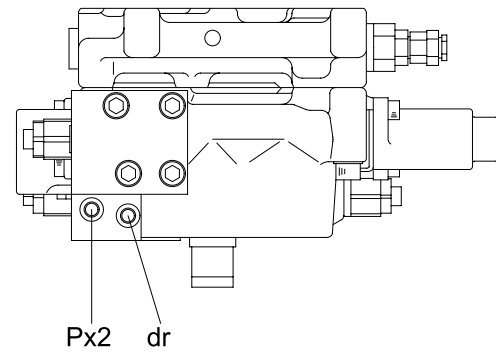

VIEW X

MARK	Port name	Port size
a	Arm out confluence port	PF 1/4
b	Bucket in confluence port	
c	Arm in confluence port	
d	Boom up confluence port	
DR/dr	Drain port	
dr1	Drain port	
dr2	Drain port	
FL	Negative control signal port(PL port side)	
FR	Negative control signal port(PR port side)	
Pi	Pilot pressure port	
3Pi	Lock valve pilot port(Boom)	
4Pi	Lock valve pilot port(Arm)	
4Pc	Swing logic valve pilot port	
Px1	Signal port for attachment	
Px2	Pilot pressure port for lock valve(Boom)	
Py1	Signal port for travel	PF 3/8
Py2	Main relief pilot pressure port	
al*	Pilot port	
ar*	Pilot port	
bl*	Pilot port	PF 1
br*	Pilot port	
Rs	Swing motor make up port	
AL1	Swing motor port(RH)	
AL2	Arm head side port(In)	
AL3	Option port	
AL4	Travel motor port(LH, Forward)	
AR1	Boom rod side port(Down)	
AR2	Bucket head side port(In)	
AR3	Travel motor port(RH, Forward)	
BL1	Swing motor port(LH)	
BL2	Arm rod side port(Out)	
BL3	Option port	
BL4	Travel motor port(LH, Reverse)	
BR1	Boom head side port(Up)	
BR2	Bucket rod side port(Out)	
BR3	Travel motor port(RH, Reverse)	
R	Return port	ø 50

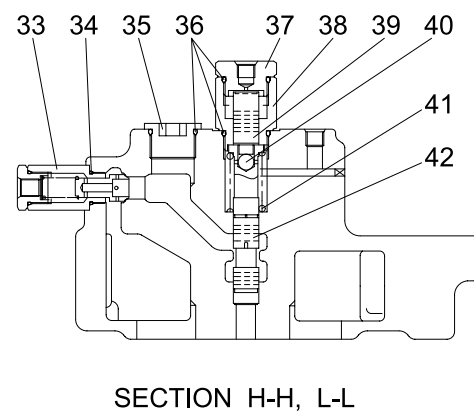
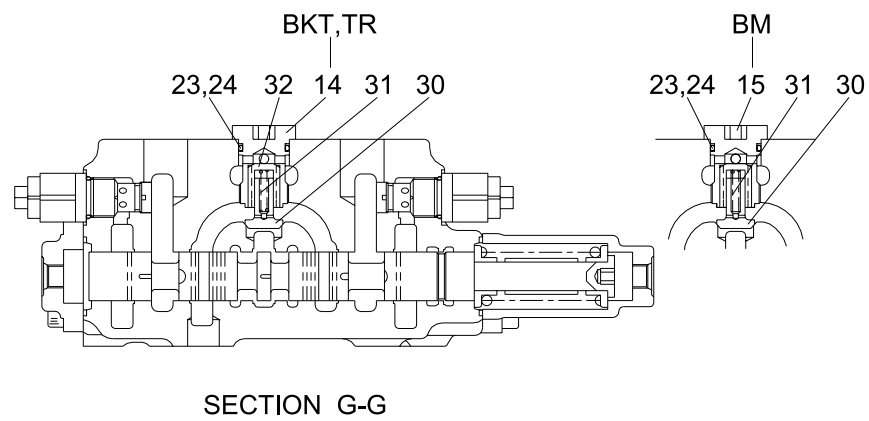
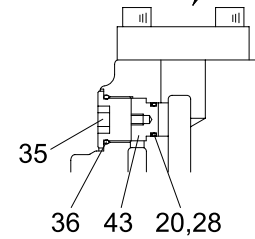
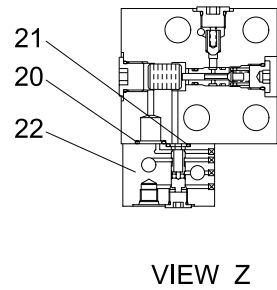
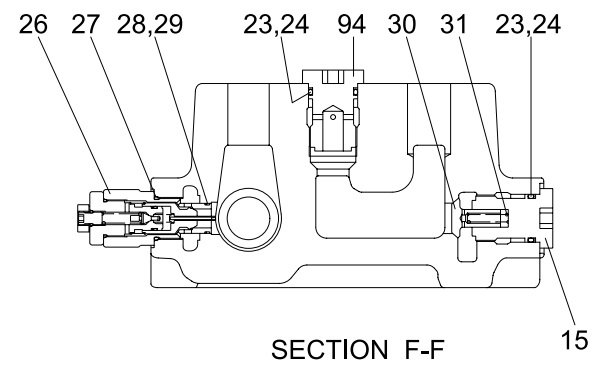
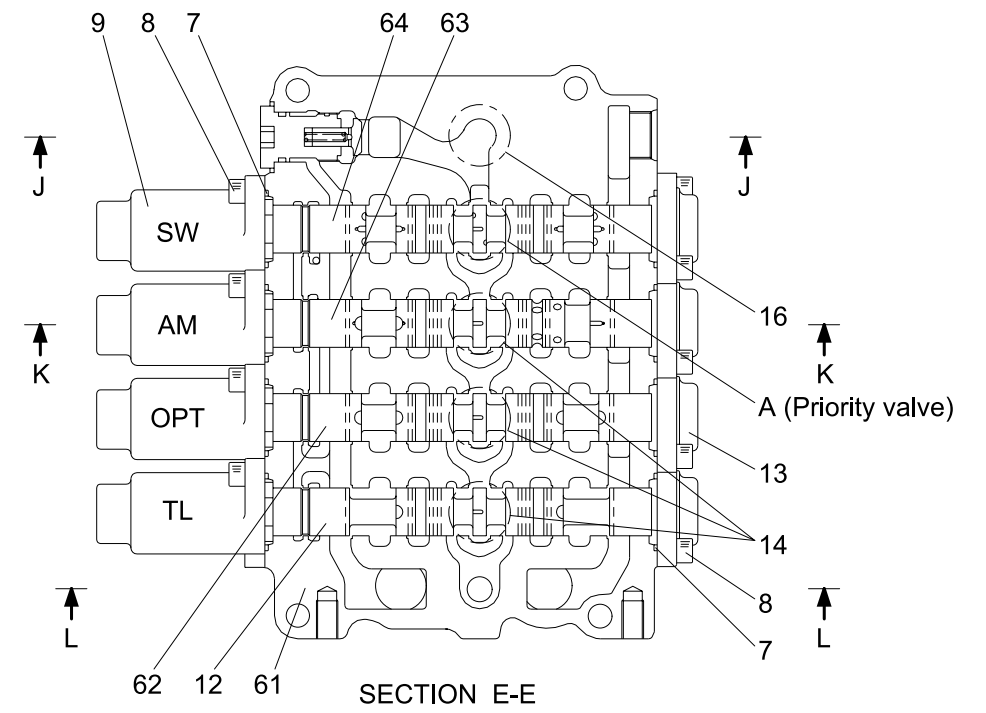
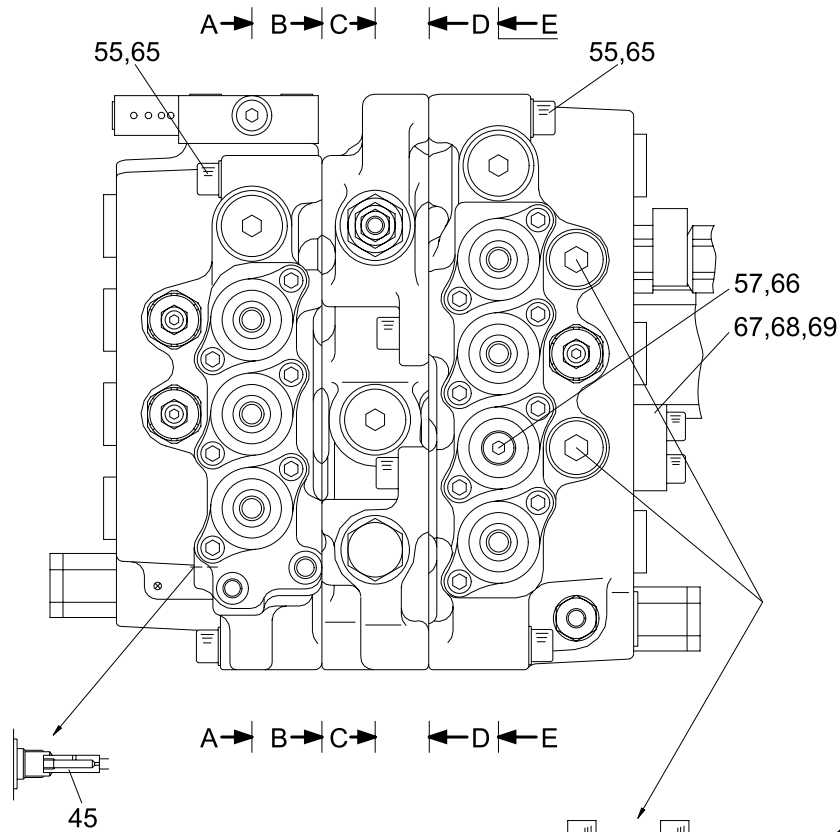
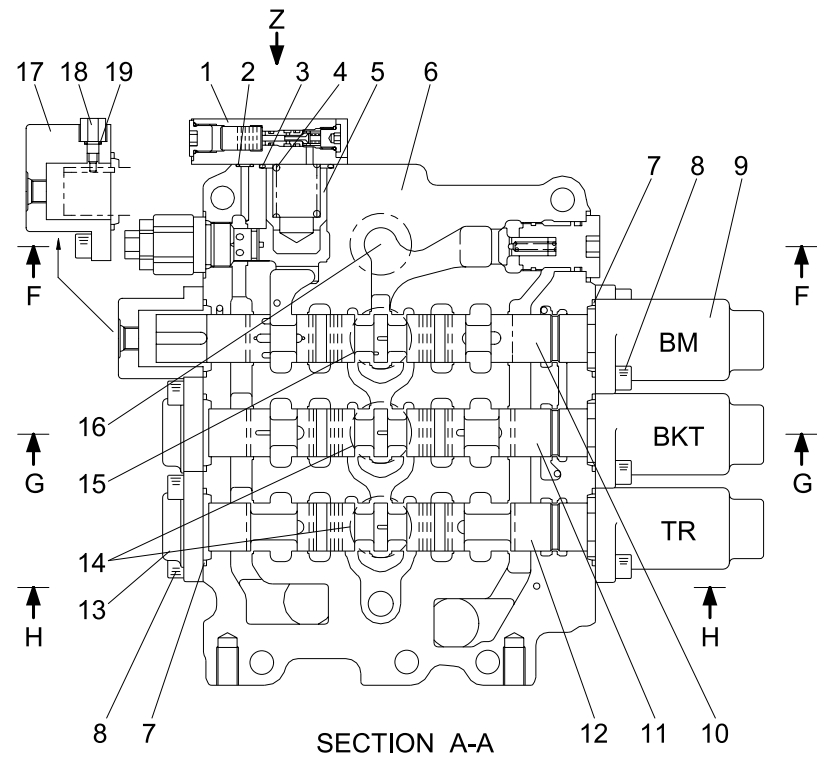

1	Cover assy	33	Foot relief valve	64	Swing plunger assy
2	O-ring	34	O-ring	65	Socket bolt
3	O-ring	35	Cap	66	O-ring
4	Spring	36	O-ring	67	Flange
5	Poppet	37	Cap	68	O-ring
6	Housing	38	Cap	69	Socket bolt
7	O-ring	39	Piston	70	Poppet
8	Socket bolt	40	Steel ball	71	Spring
9	Cover	41	Spring	72	O-ring
10	Boom plunger assy	42	Spool	73	Back up ring
11	Bucket plunger assy	43	Plug	74	Cover assy
12	Travel plunger assy	44	Cap	75	Socket bolt
13	Cover	45	Orifice	76	Lock washer
14	Cap	46	Spool	77	Manifold
15	Cap	47	Spring	78	O-ring
16	Cap	48	Cap	79	Cap
17	Cover	49	Main relief valve	80	Piston
18	Plug	50	O-ring	81	Spring
19	O-ring	51	Manifold	82	O-ring
20	O-ring	52	Logic check valve	83	Sleeve
21	O-ring	53	O-ring	84	Spring
22	Selector assy	54	Socket bolt	85	Check
23	Back up ring	55	Washer	86	Poppet
24	O-ring	56	O-ring	87	Cap
26	Overload relief valve	57	Cap	88	Spring guide
27	O-ring	58	O-ring	89	Spring
28	Back up ring	59	O-ring	90	Union
29	O-ring	60	Socket bolt	91	Piston
30	Check	61	Housing	92	Cap
31	Spring	62	Option plunger assy	93	O-ring
32	Check	63	Arm plunger assy	94	Cap

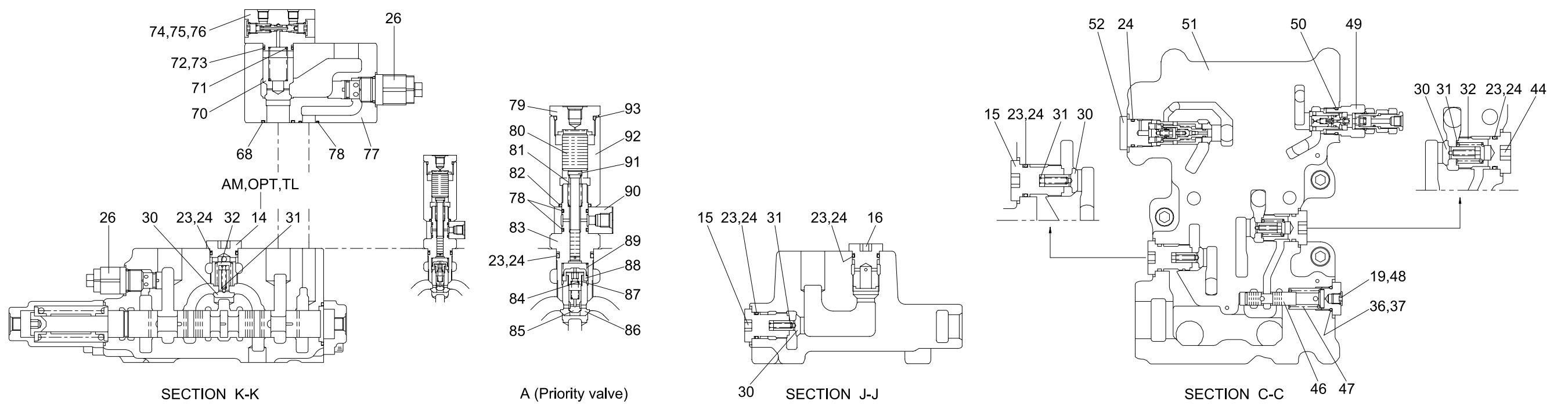
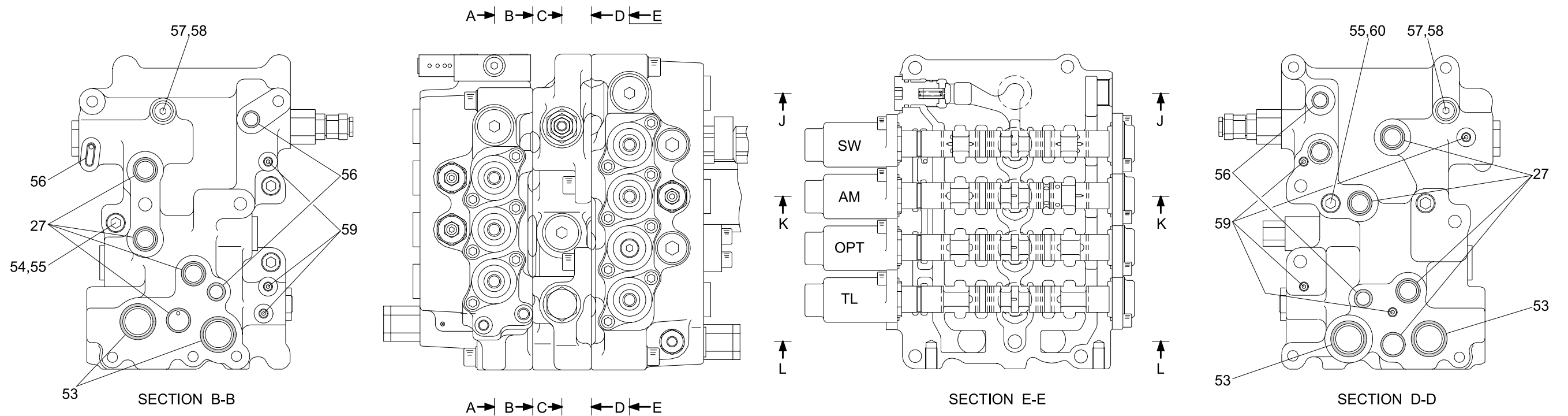

## 2) BASIC OPERATION

### (1) Travel straight circuit

This circuit keeps straight travel in case of simultaneous operation of other actuators (SW, AM, BKT, BM) during a straight travel.

#### During straight travel by operating left/right travel plunger (TL, TR):

Operation of travel spool, the pilot signal(Py1) line inside the control valve is blocked, but the pilot signal(PX1) line is connected to the tank via orifice therefore, the travel straight select valve is not operated ; oil from pump PL is fed into cylinder port BL4 only.

Oil from pump PR is fed into cylinder port BR3 by the operation of TR plunger. Thus, straight travel is performed separately with pump PL driving rightward travel(TL) and pump PR driving rightward travel(TR).

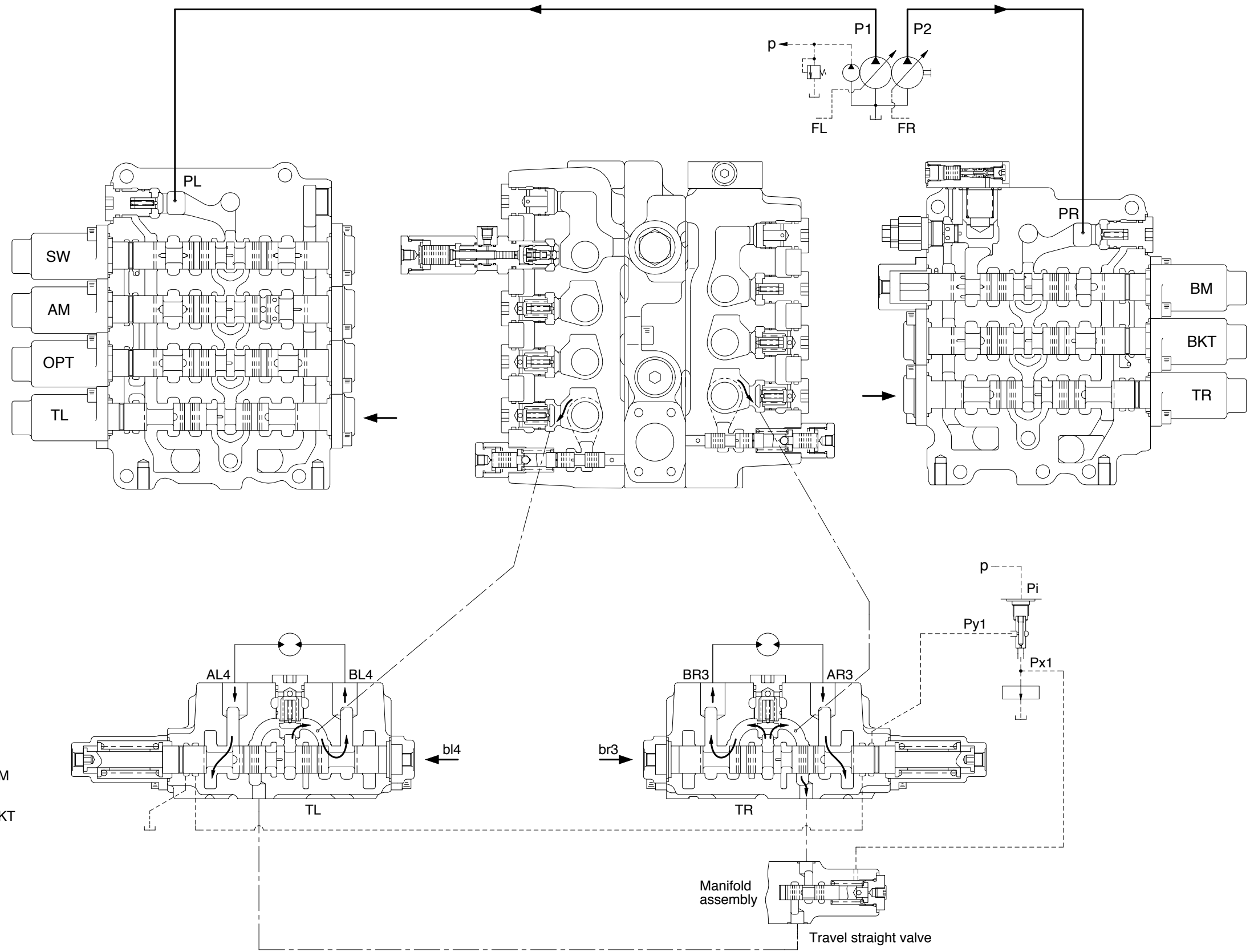

**In case of a swing operation during straight travel for instance :**

At the beginning of swing plunger stroke the pilot signal(Px1) line inside the control valve is blocked and the signal pressure makes the connection between the feed passages of right and left travel plungers(TL, TR) by switching spool of travel straight select valve. When the swing plunger is switched, oil discharged from pump PR preferentially flows into swing motor which is positioned upstream.

Thus, simultaneous operation of swing and straight travel is made possible as oil from pump PL is fed to swing and oil from pump PR is fed to right travel(TR) and left travel (TL).

The orifice at the upstream of the parallel feed passage sends surplus oil of swing to right and left travel(TL, TR) to avoid abrupt change of the vehicle speed.

The basic operation is same with swing even in the case of other actuators on upper frame of machine during straight travel.

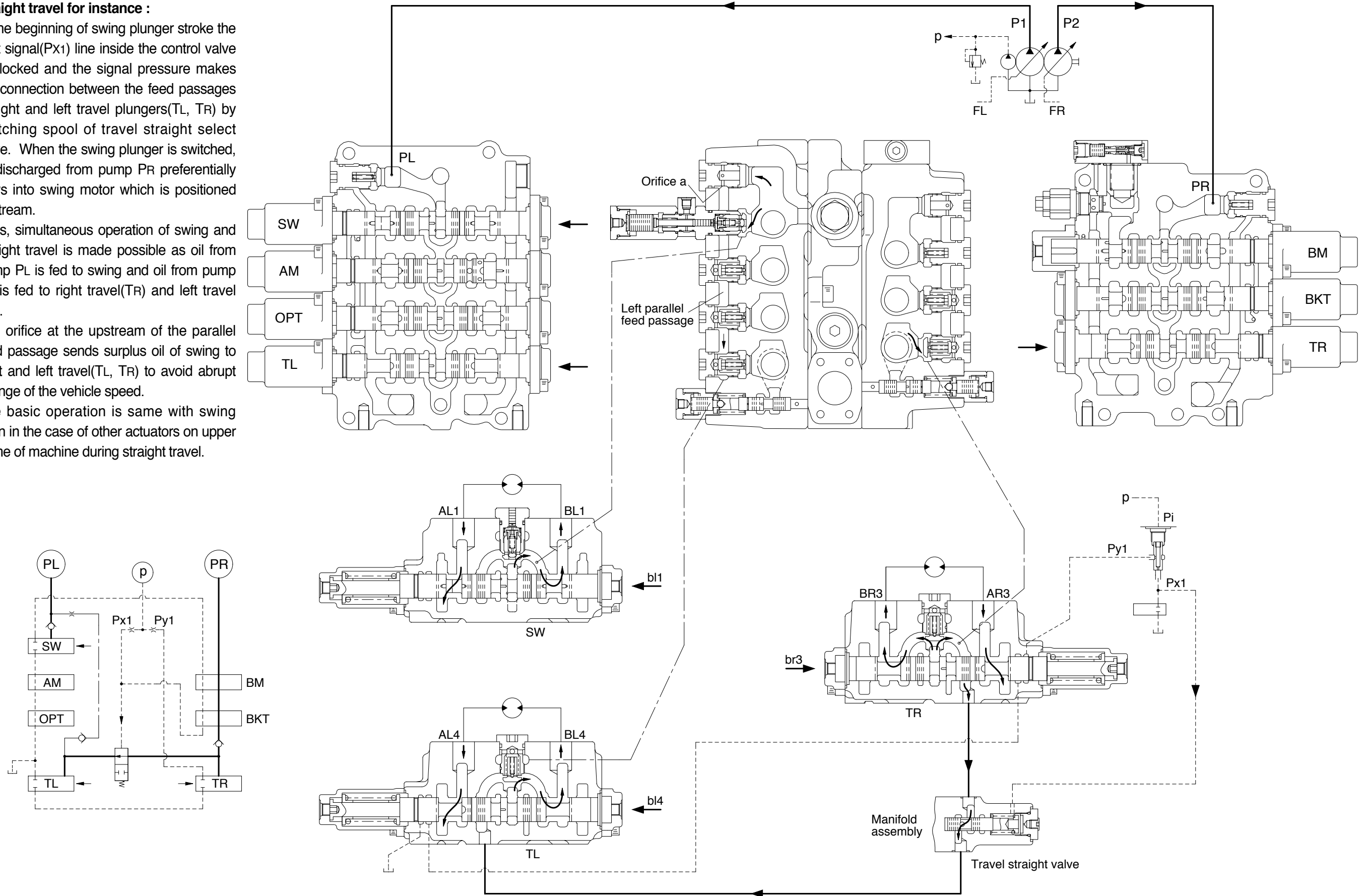

**(2) Arm flow summation circuit**

**· Arm out operation**

Oil from pump PL is fed into cylinder port BL2 by adding pressure to arm plunger pilot port b12.

Oil from pump PR flows into the center bypass valve assembly via the center bypass passage. Since the same pilot pressure of the arm plunger pilot port is applied to the pilot signal port of the center bypass valve assembly, the center bypass spool is switched; pushing up the arm flow summation check valve in the manifold through center bypass passage of RH travel section. Oil flows into the high pressure feed passage, and joins to the flow from the pump PL.

· Arm in operation is same as above, summing the flow of the PL pump. (Pilot signal pressure is applied a port.)

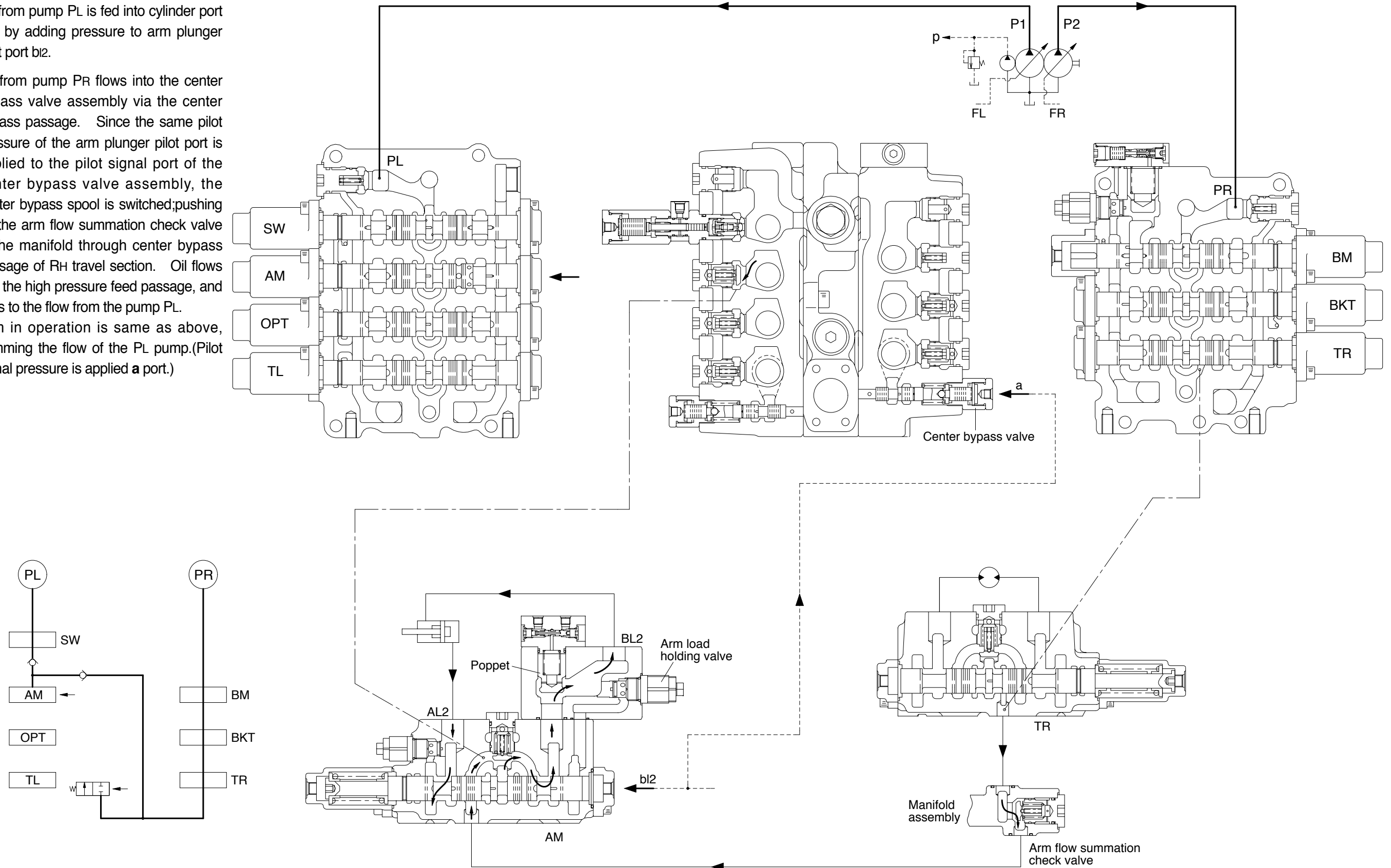

### (3) Boom up flow summation circuit

Oil from pump PR is fed into cylinder port BR1 by adding pressure to boom plunger pilot port br1.

Oil from pump PL flows into spool of the center bypass valve assembly via the center bypass passage. Since the same pilot pressure of the boom plunger pilot port is applied to the pilot port(b), the center bypass spool assembly closes. At the same time, boom(up) signal works on the logic check valve and the valve opens; oil flows from the center bypass passage of swing section through the logic check assembly into the boom high pressure feed passage and joins to the flow from the pump PR.

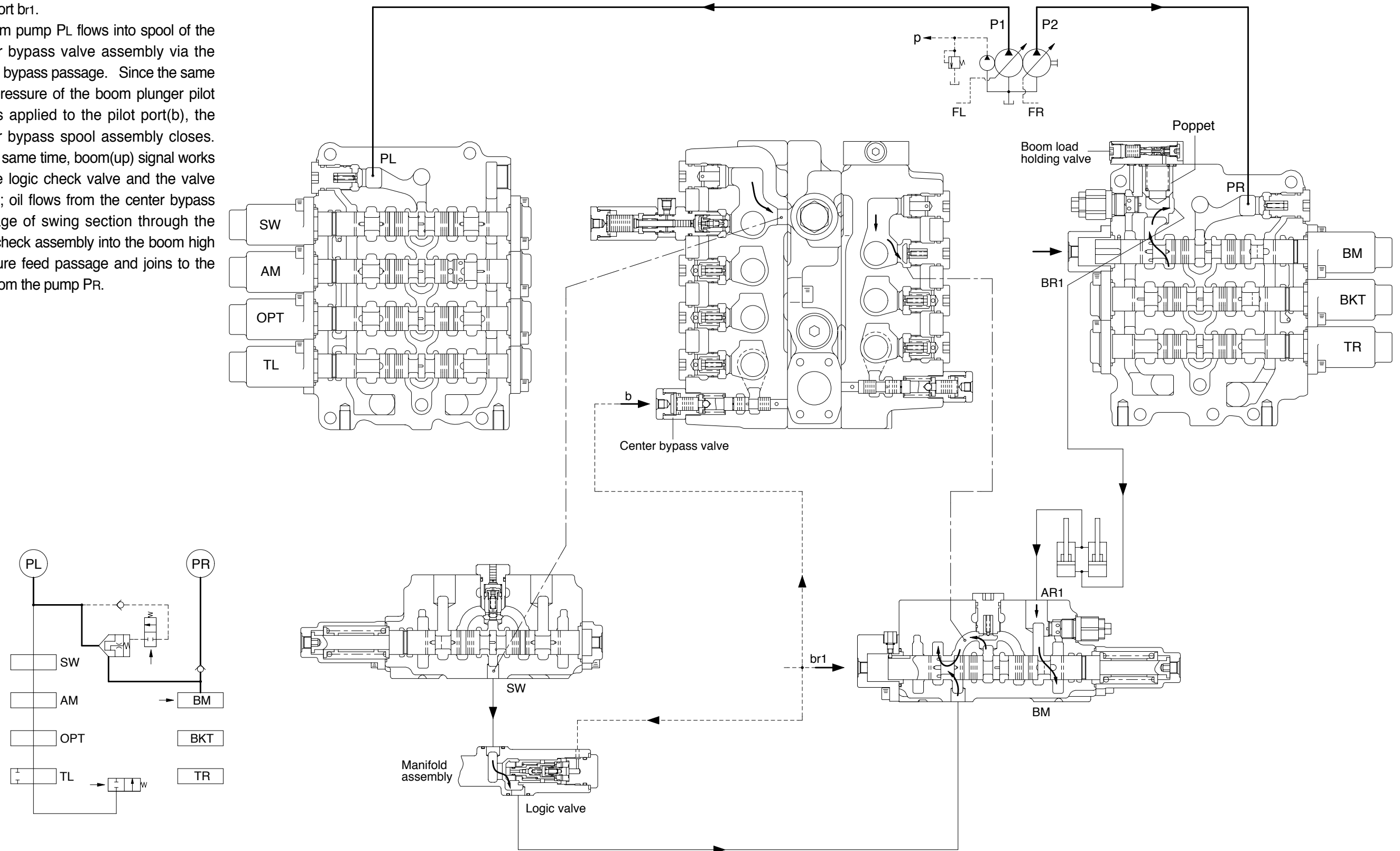

## 2) OPERATIONAL DESCRIPTION OF CONTROL VALVE

### (1) Plunger operation

#### Neutral position of plunger

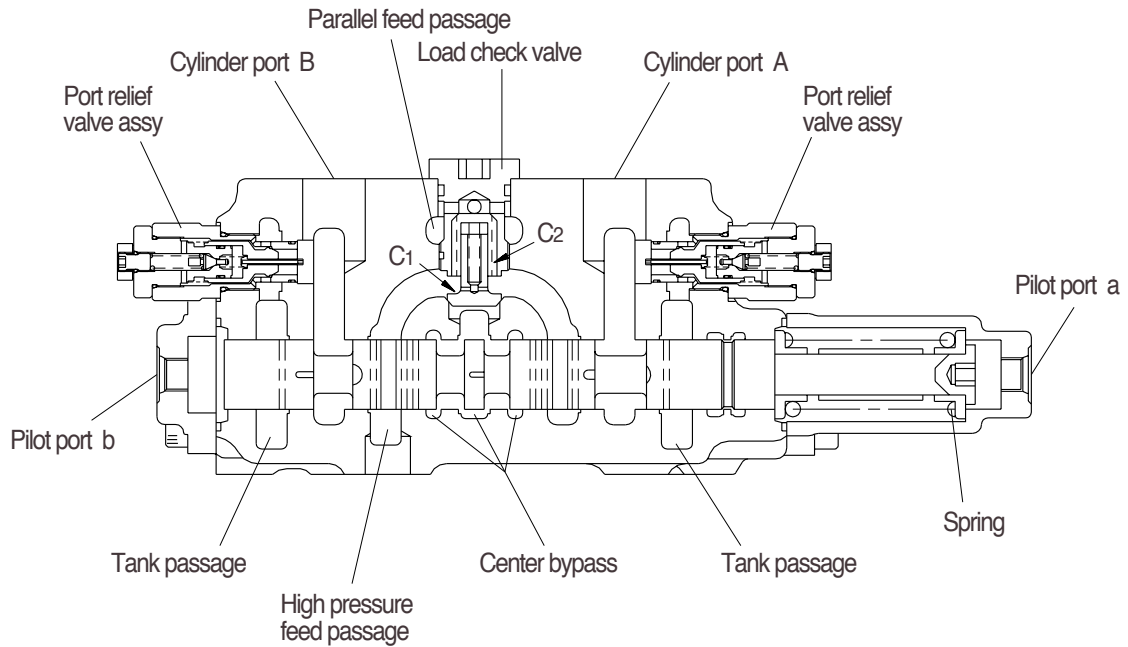

360SMCV10

In neutral, spring sets the plunger at the neutral position; the high pressure feed passage is shut off by the plunger; oil from the pump flows through the center bypass.

## Operation of plunger

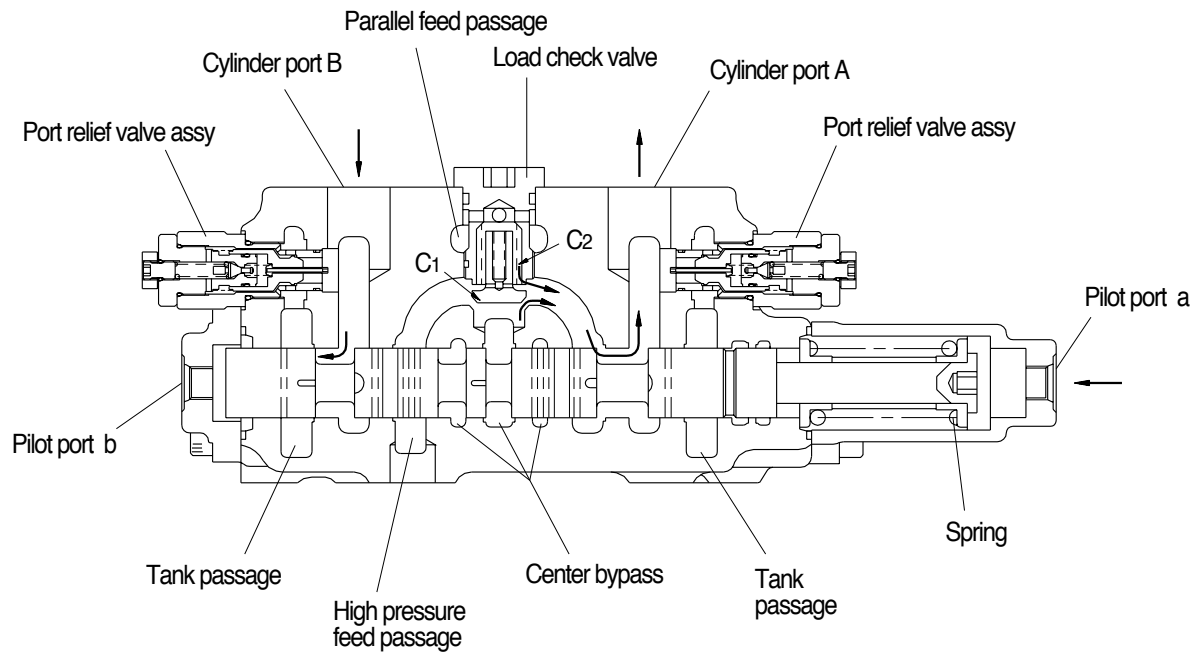

360SMCV11

When actuated (pressure is applied to pilot port a), the plunger moves to the left; the center bypass is shut off; oil from the center bypass pushes up the check valve C<sub>1</sub> and flows into cylinder port A via the high pressure feed passage. Meanwhile, oil from the parallel feed passage pushes down check valve C<sub>2</sub> and flows into cylinder port A via the high pressure feed passage.

The return oil from cylinder port B flows into the tank via the tank passage.

Reversed when pressure is applied to pilot port b.

**(2) Foot relief valve operation**  
 **$f_p$  is lower than spring force**

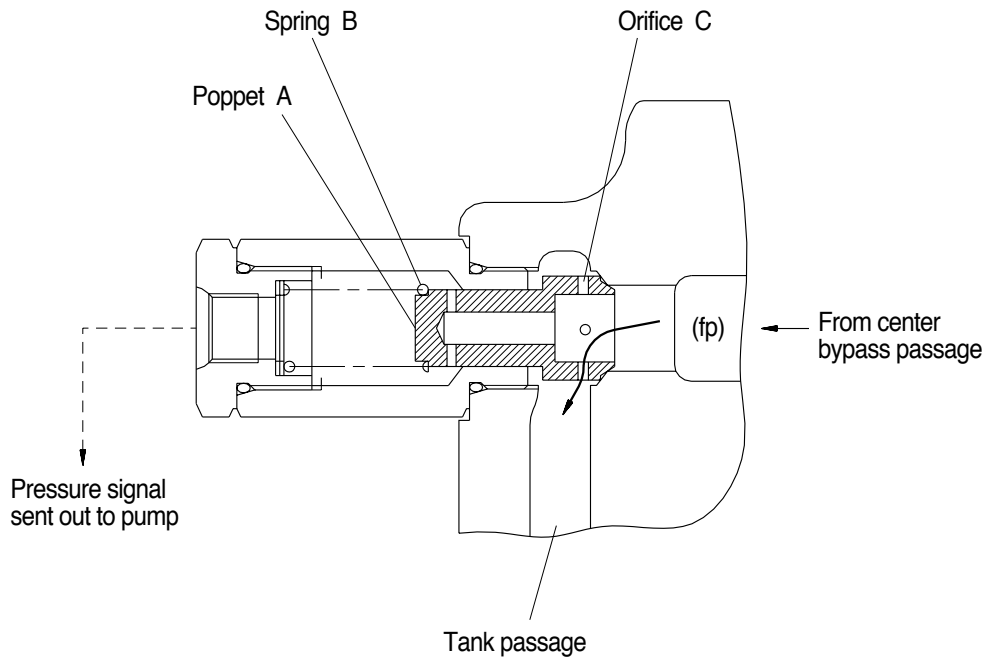

360SMCV17(1)

Hydraulic oil from the center bypass passage flows into the tank via orifice(C) of poppet(A). Pressure  $f_p$  generated by orifice(C) is led to the pump, to control the pump delivery flow.

**$f_p$  is higher than spring force**

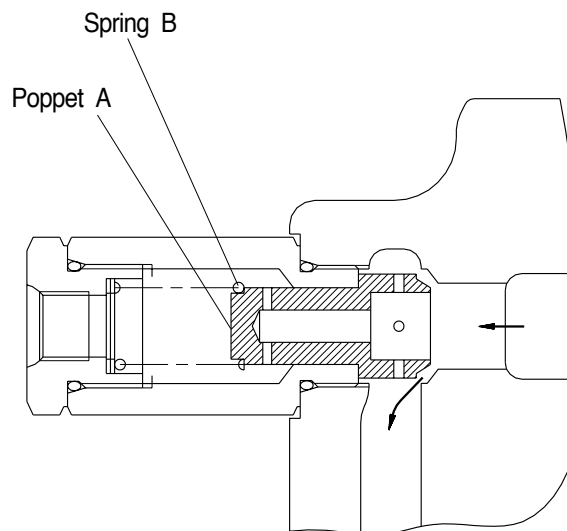

360SMCV17(2)

If a large amount flows due to delayed pump response, etc., and pressure  $f_p$  reaches the preset spring(B) force, then the poppet(A) is lifted and functions as a relief valve.

### (3) Logic check valve operation

#### Boom down or neutral

When boom up pilot pressure is not supplied.

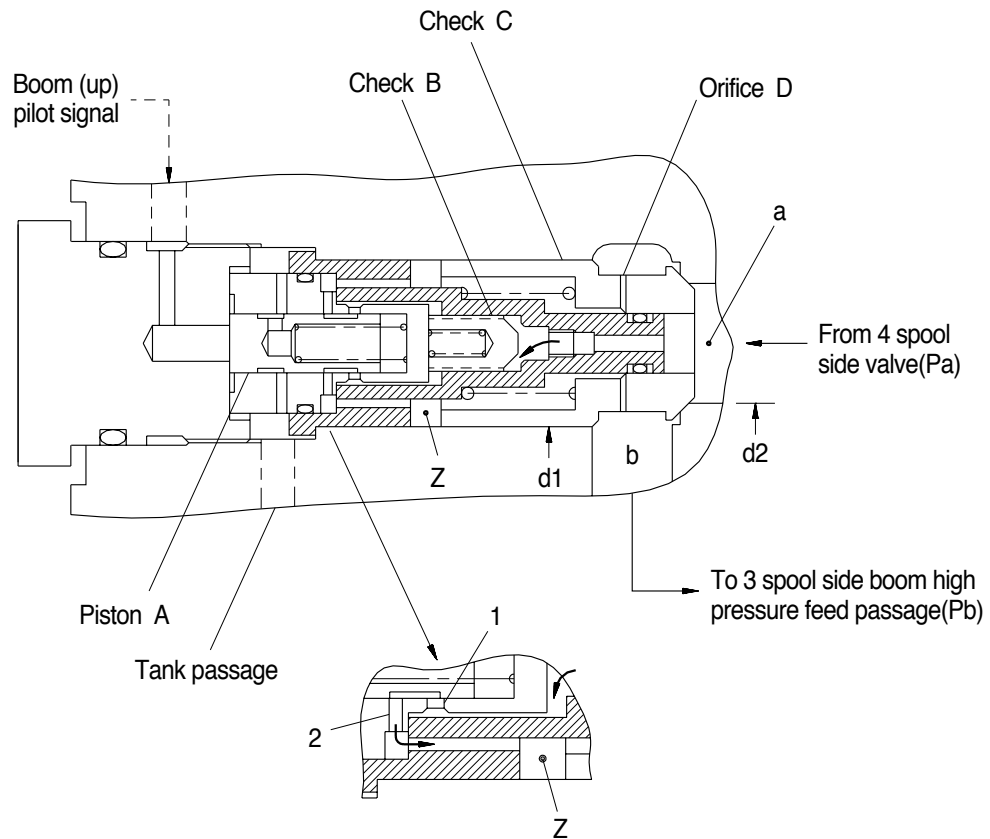

360SMCV23(1)

Spring force sets piston (A) in the shown position;

Pressure in the passage a ( $P_a$ ) enters chamber (Z) via passage (1) and passage(2).

Pressure in the passage b ( $P_b$ ) enters chamber (Z) via orifice(D).

#### If $P_a > P_b$

Check valve (C) is seated by area  $d_1 > d_2$  and passage from a to b is blocked.

#### If $P_a < P_b$

Passage from b to a is blocked by the check valve (C).

## Boom up

When boom up pilot pressure is supplied.

Piston (A) moves to right; passage (1) is shut off from passage (2).

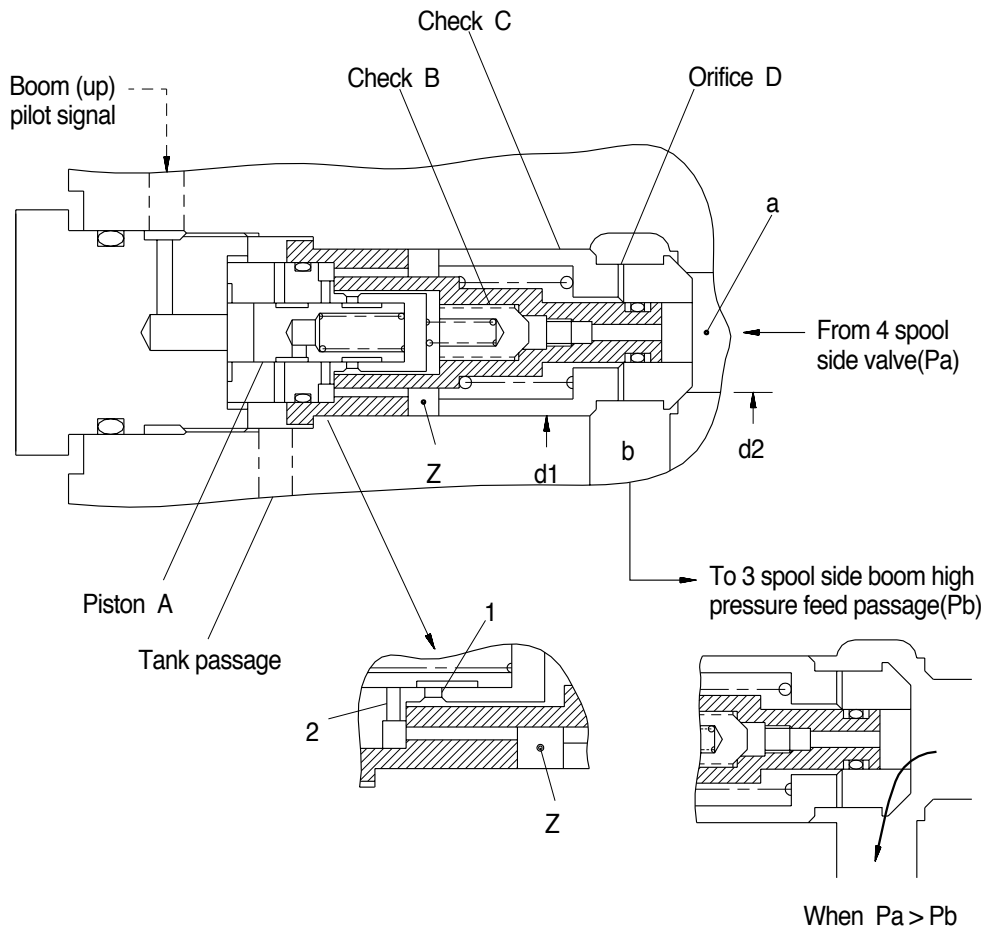

360SMCV23(2)

## When $P_a > P_b$

Check valve (C) is lifted as the shown position; oil flows through from a to b.

## When $P_a < P_b$

Passage from b to a is blocked by the check valve (C), because  $d_1 > d_2$ .

#### (4) Main relief valve operation

##### High pressure setting pilot signal : OFF

Piston (D) is seated to the right by spring (C) force.

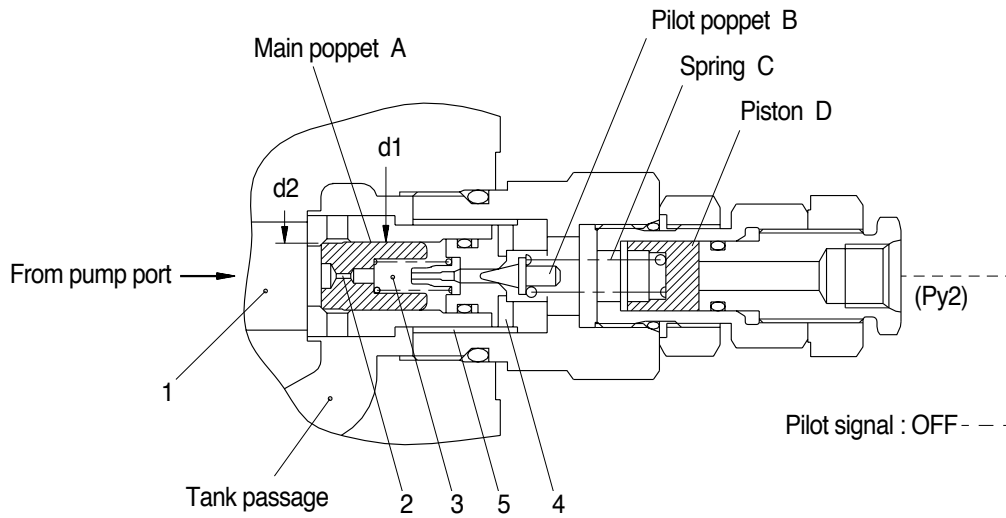

360SMCV12(1)

This relief valve is built-in between the pump port side (1) and tank passage.

Hydraulic oil from the pump port side enters chamber (3) via orifice (2) of poppet (A). Because  $d_1 > d_2$ , poppets (A) is securely seated.

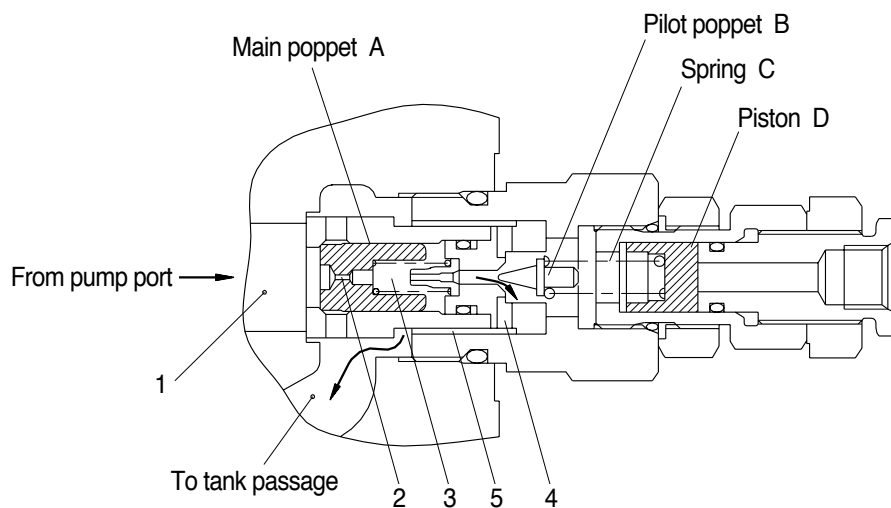

360SMCV12(2)

When hydraulic oil reaches the pressure preset by spring (C), pilot poppet (B) opens; oil flows around pilot poppet (B) and into the tank passage via side hole (4) and passage (5).

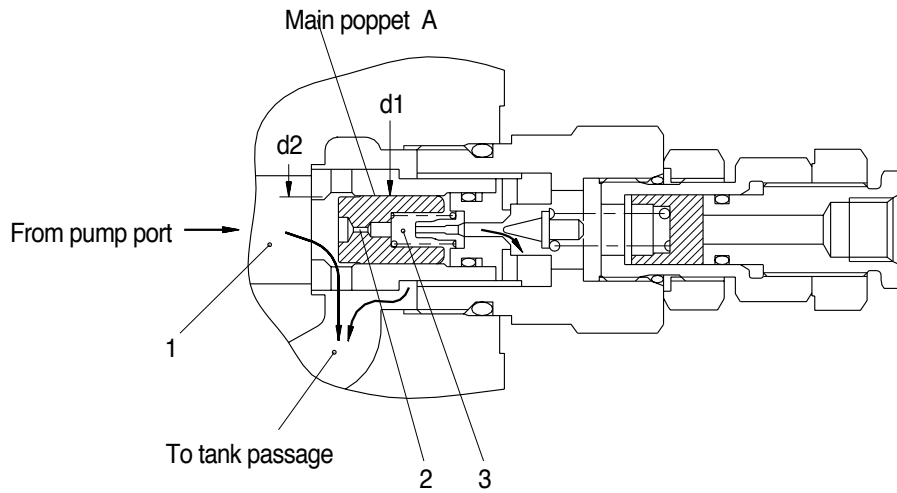

360SMCV13(1)

When the above oil flow is formed, pressure drops before and behind orifice (2); when pressure of chamber (1) x area  $d_2$  is larger than pressure of chamber (3) x area  $d_1$ , main poppet (A) is lifted and hydraulic oil flows into the tank passage.

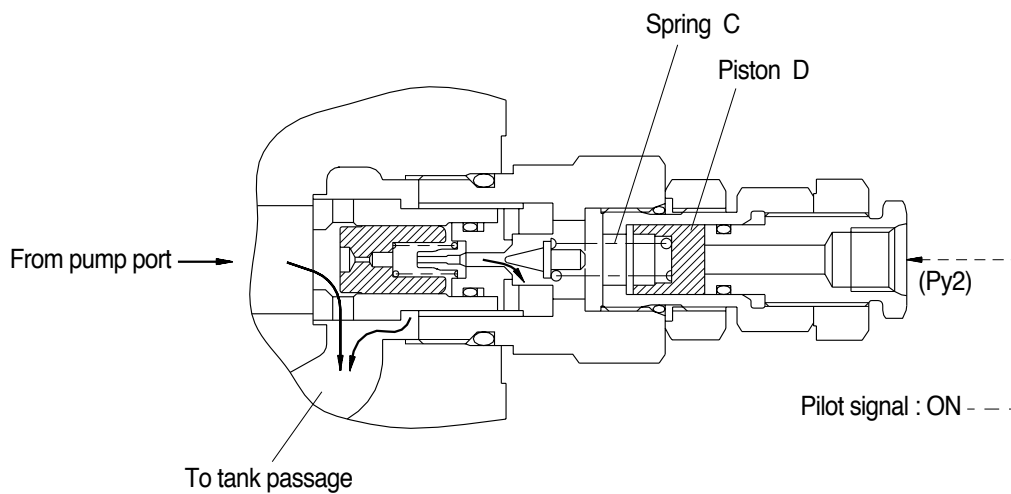

360SMCV13(2)

**High pressure setting pilot signal : ON**

Piston (D) moves to left; set pressure of spring (C) rises, making high pressure setting.

**(5) Overload relief valve operation**  
**Overload working operation**

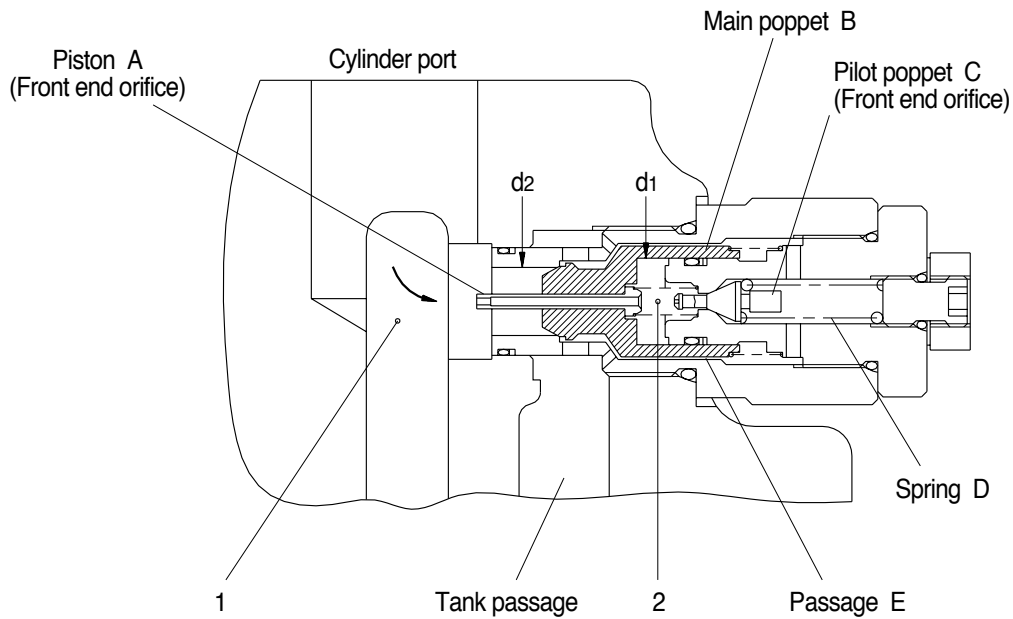

360SMCV14(1)

Hydraulic oil from cylinder port enters chamber (2) via orifice of piston (A). Because  $d_1 > d_2$ , main poppet (B) is securely seated.

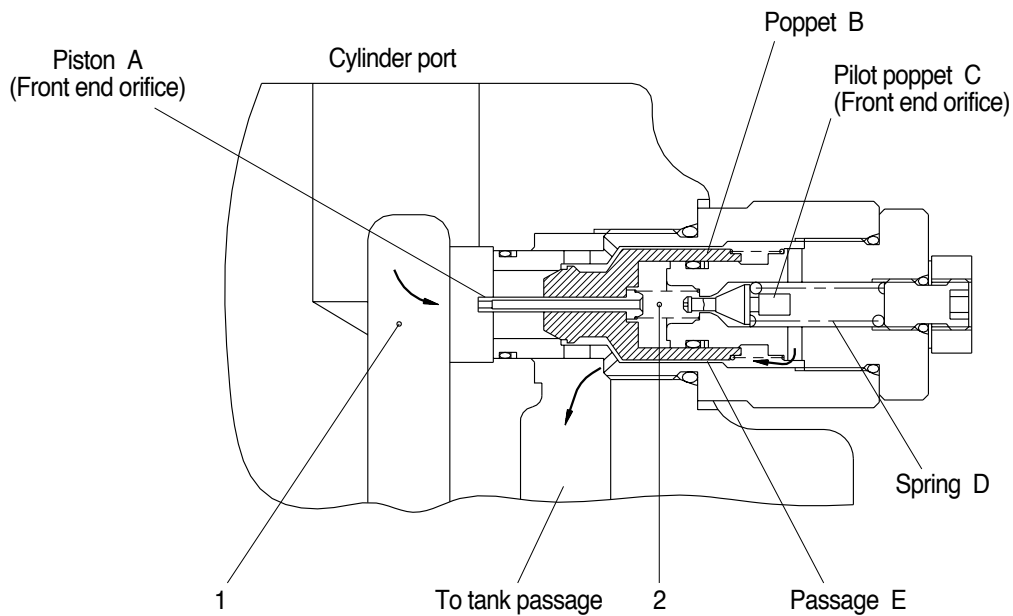

360SMCV14(2)

When hydraulic pressure reaches the preset force of spring (D), pilot poppet (C) opens; oil flows around poppet (C) and into the tank passage via side hole and passage (E).

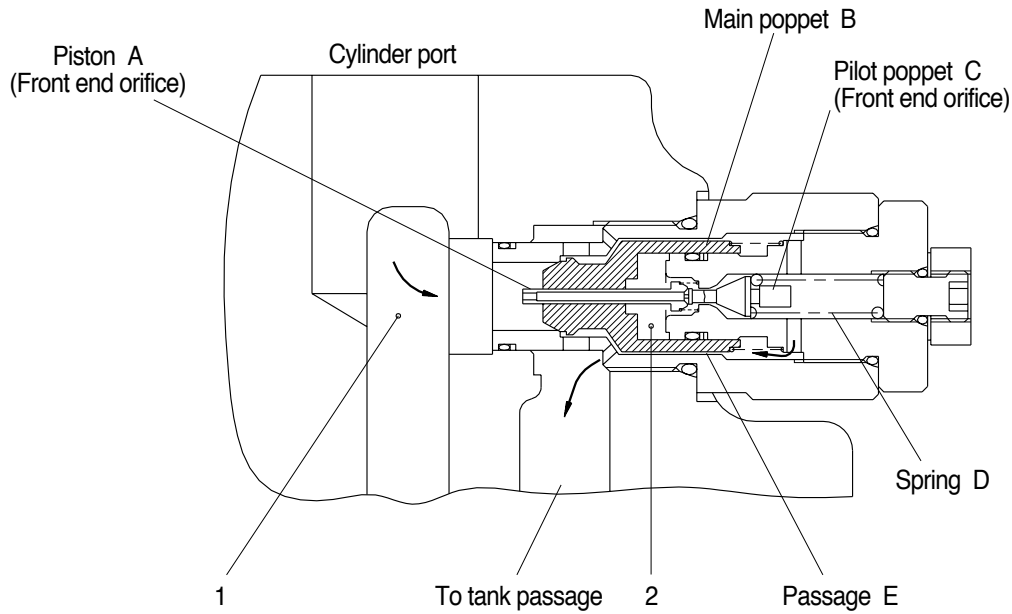

360SMCV15(1)

Oil flow is formed; pressure drops before and behind orifice of piston (A); piston (A) moves to right and seats at the tip of pilot poppet (C).

Hydraulic oil from chamber (1) flows into the tank passage via orifice of piston (A) and pilot poppet (C), side hole and passage (E).

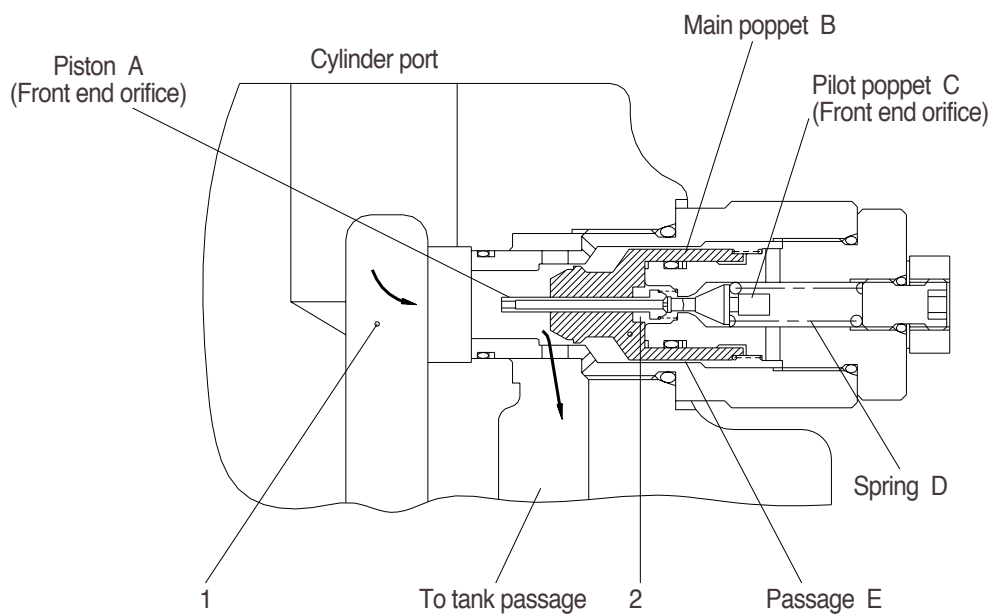

36072MCX

Pressure drops before and behind orifice of pilot poppet (C), making pressure of chamber (1) > pressure of chamber (2); poppet (B) is lifted and hydraulic oil flows into the tank passage.

## Make up operation

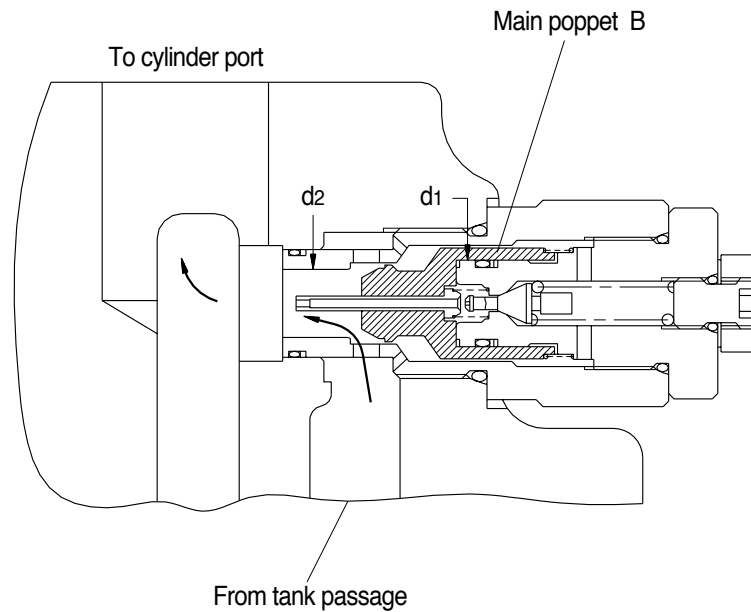

360SMCV16

Poppet (B) is securely seated because the cylinder port pressure is normally higher than the tank pressure and  $d_1 > d_2$ .

When the cylinder port pressure drops (closer to negative pressure) until the cylinder port pressure is lower than the tank pressure, poppet (B) opens receiving the tank pressure for the difference in area between  $d_1$  and  $d_2$ ; oil flows from the tank passage to the cylinder port in order to prevent cavitation.

**(6) Arm regeneration circuit**  
**Arm in operation**

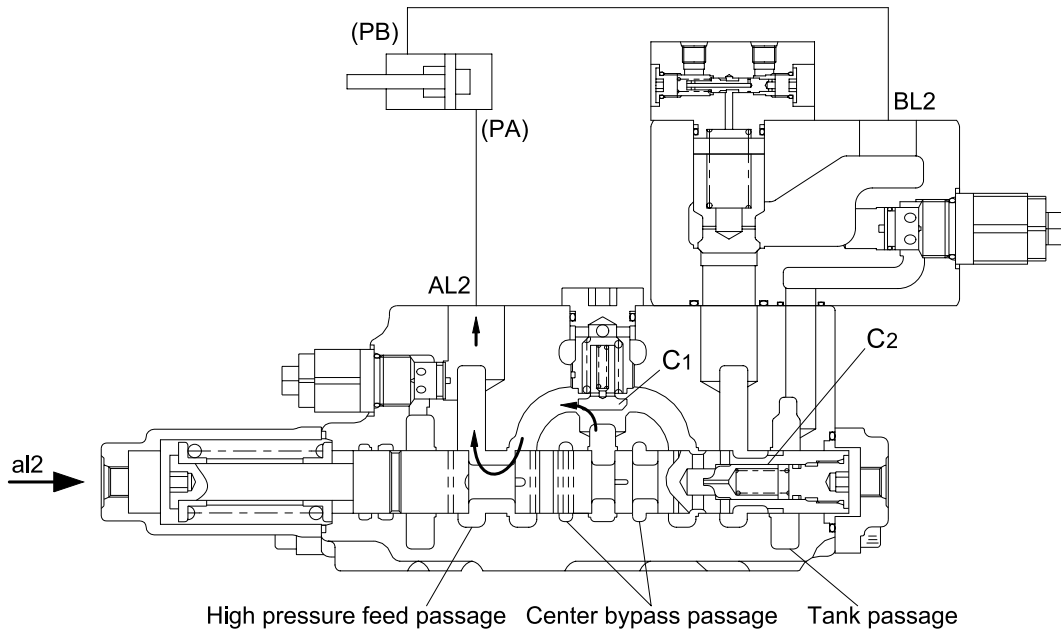

36072MC11

When pressure is applied to pilot port a2 of the arm plunger, the plunger moves to right as shown; the center bypass passage is shut off; oil from the center bypass pushes up check valve (C1) and flows into cylinder bottom port via the high pressure feed passage.

**PA is lower than PB**

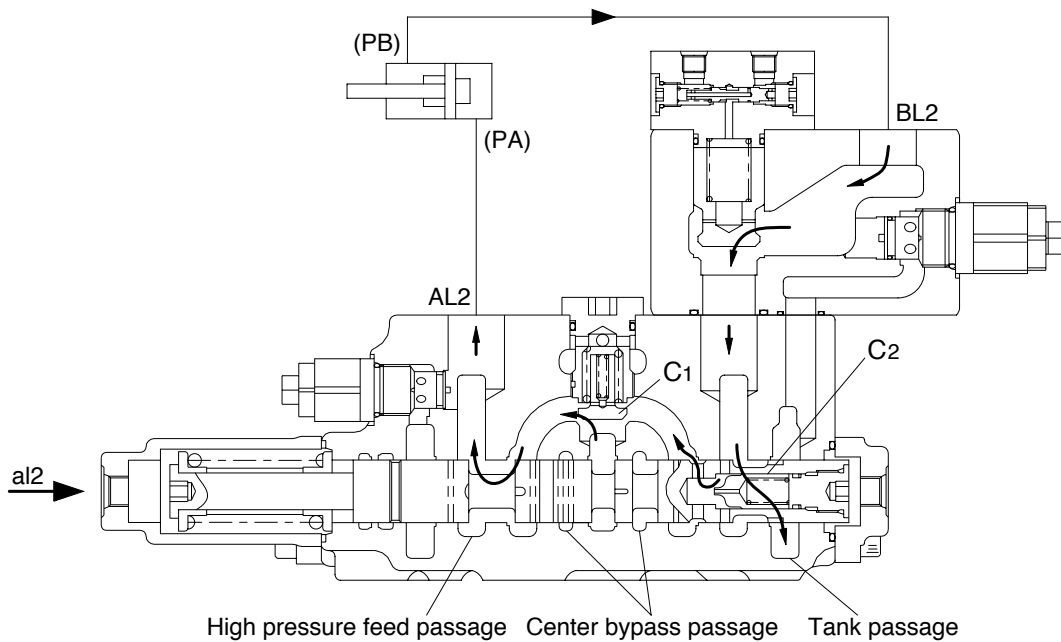

36072MC12

Return oil from cylinder rod side pushes up check valve (C2) in the plunger; it flows into cylinder bottom side after returning to the high pressure feed passage.

**PA is higher than PB**

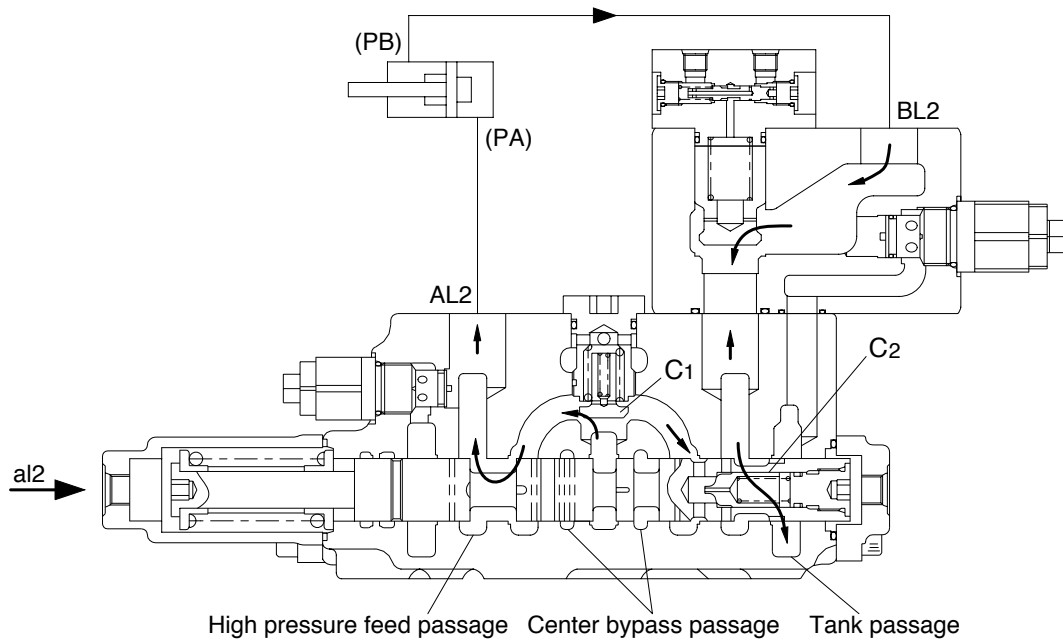

36072MC13

The check (C2) is seated by the pressure (PA) of cylinder bottom side, the return oil from cylinder rod side flows into the tank passage.

**(7) Boom load holding valve operation**

**When the plunger is in neutral (3Pi pilot signal : OFF)**

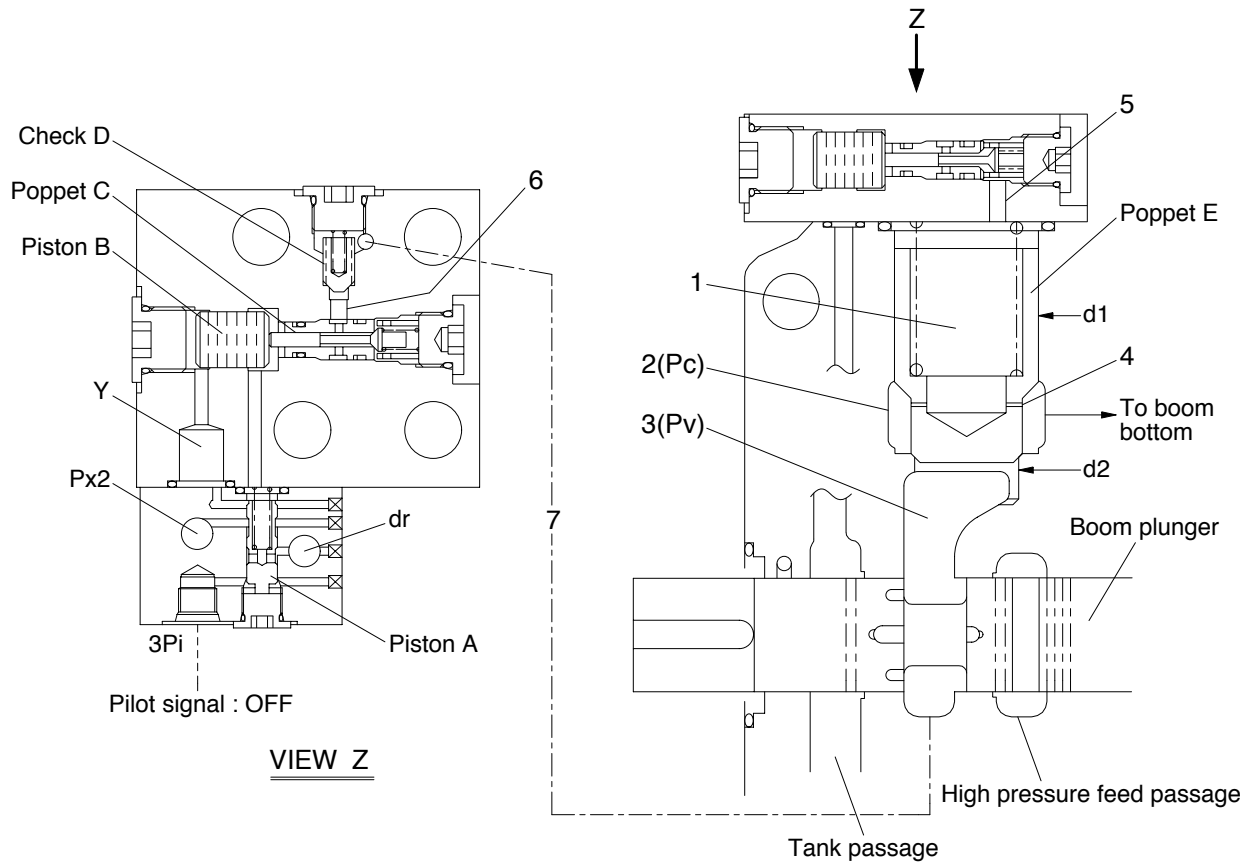

36072MC14

The piston(A) is in the status as shown and the passage from pilot signal(Px2) to chamber(Y) is blocked.

Therefore, piston (B) and poppet (C) are in the status as shown; passages (5) and (6) are shut off by poppet (C).

Therefore, the pressure of chamber (1) becomes PC as it is connected with chamber (2) via orifice (4). Since  $d1 > d2$ , check (D) is seated, chambers (2) and (3) are completely blocked.

**When the plunger is operated (3Pi pilot signal : OFF)**  
**A. When Pc is lower than Pv (in the case of Boom UP)**

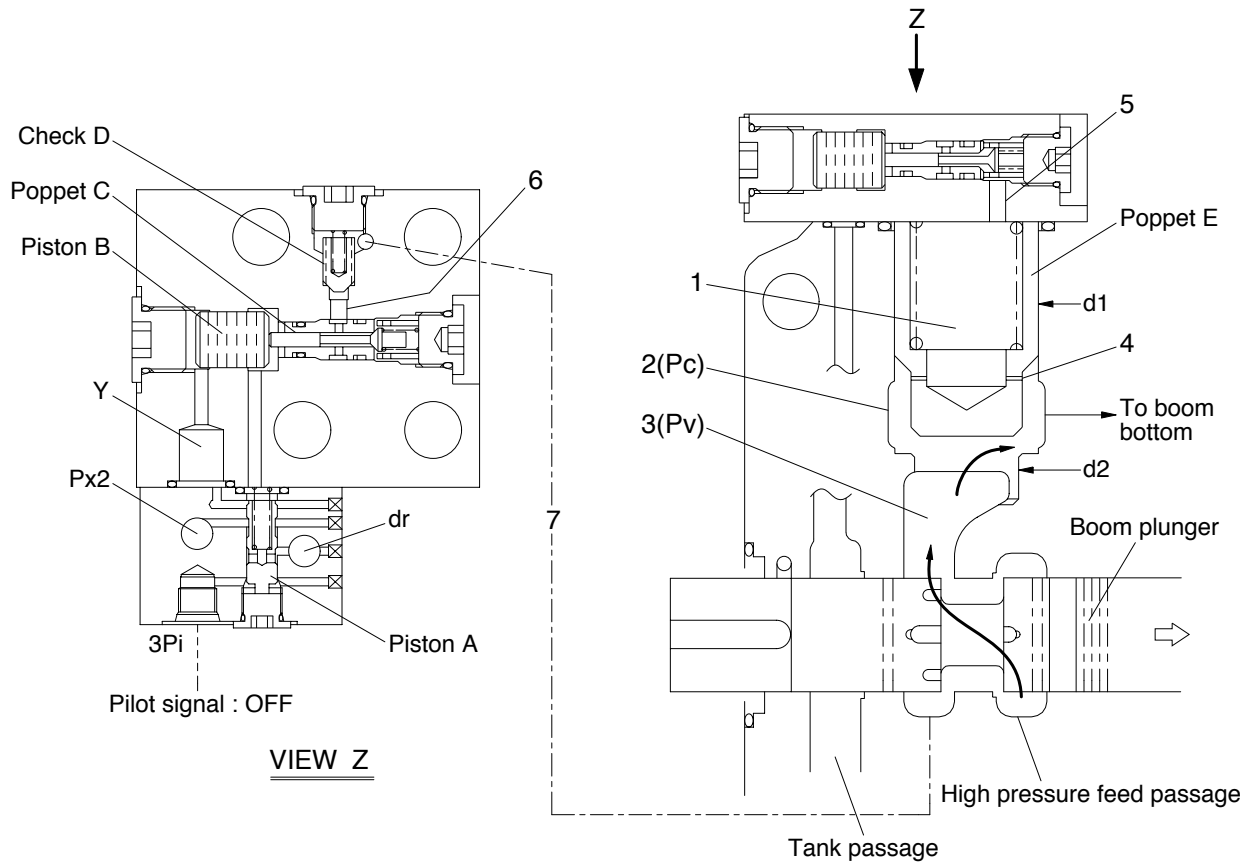

36072MC15

Because check valve (D) is seated, passages (6) and (7) are shut off. Therefore, the pressure of chamber (1) becomes  $P_c$  as it is connected to chamber (2) via orifice (4); poppet (E) is pushed up; oil from high pressure feed passage flows into the cylinder port.

**When the plunger is operated (3Pi pilot signal : ON)**  
**B. When Pc is higher than Pv (In case of Boom down)**

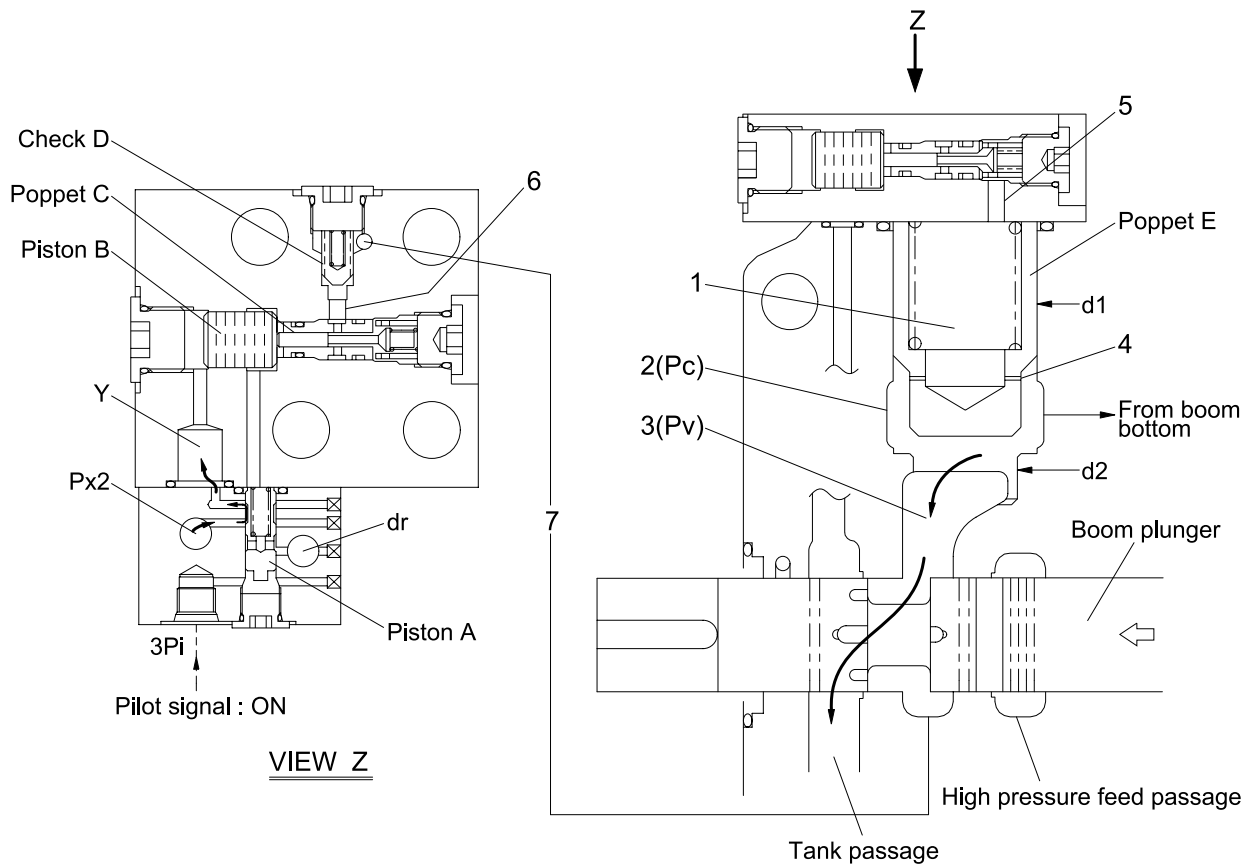

36072MC16

The piston(A) moves up and then the pilot passage(Px2) and chamber(Y) are connected. Therefore, piston (B) moves to right; poppet (C) opens; passages (5) and (6) are connected. If pressure Pc of cylinder port chamber (2) is higher than pressure Pv of chamber (3), oil from chamber (1) pushes up check valve (D) via passages (5) and (6) and enters chamber (3) through passage (7). Chamber (3) is connected with the tank passage because the boom plunger is moved to left. Therefore, pressure Pc is applied to (area d1 - area d2), pushing up check (E), and oil from the cylinder port flows into the tank passage.

**(8) Boom priority valve operation**

**When swing is operated only (4Pc pilot signal : OFF)**

**A. When  $P_o$  is lower than  $P_h$**

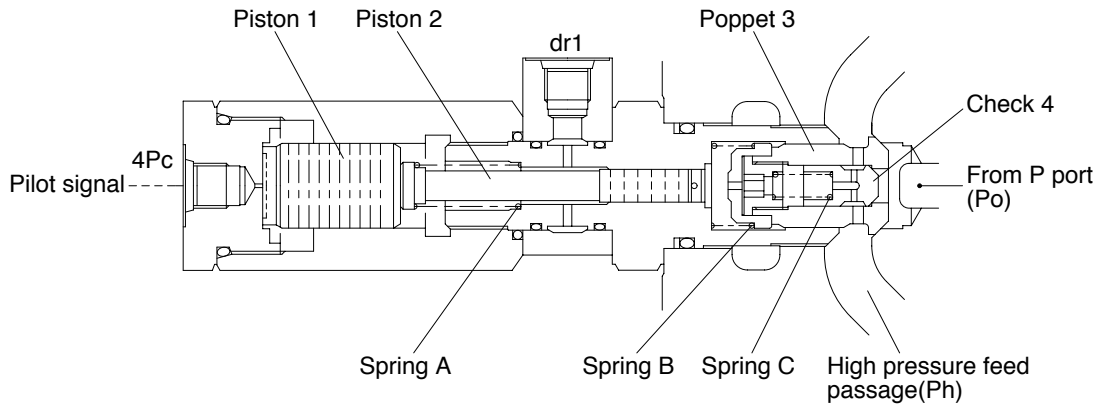

36072MC17

The piston(1) and (2) are in the position as shown by the spring (A) force, and the poppet(3) and the check(4) are seated to hold the pressure of  $P_h$ .

**B. When  $P_o$  is higher than  $P_h$**

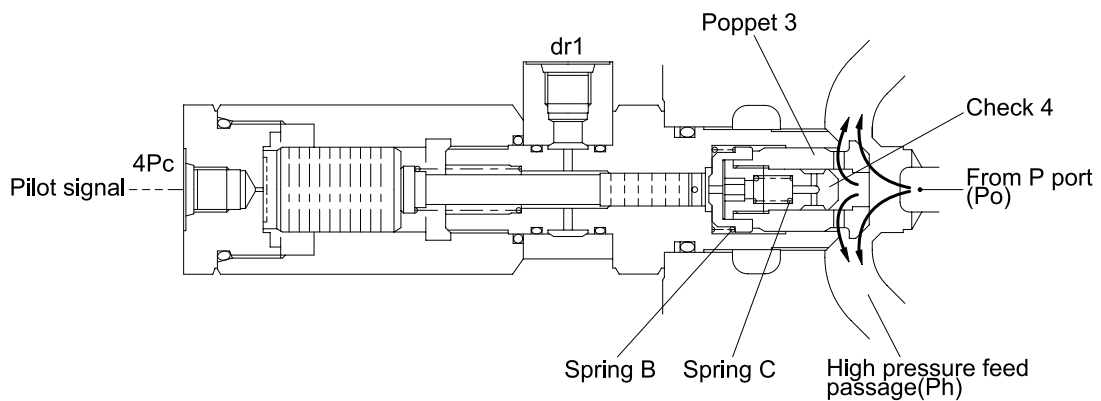

36072MC18

Oil from the P port pushes up the poppet(3) and the check(4), and flows into the high pressure feed passage connecting to the cylinder port.

**Combined swing and boom up operation(4Pc pilot signal : ON)**

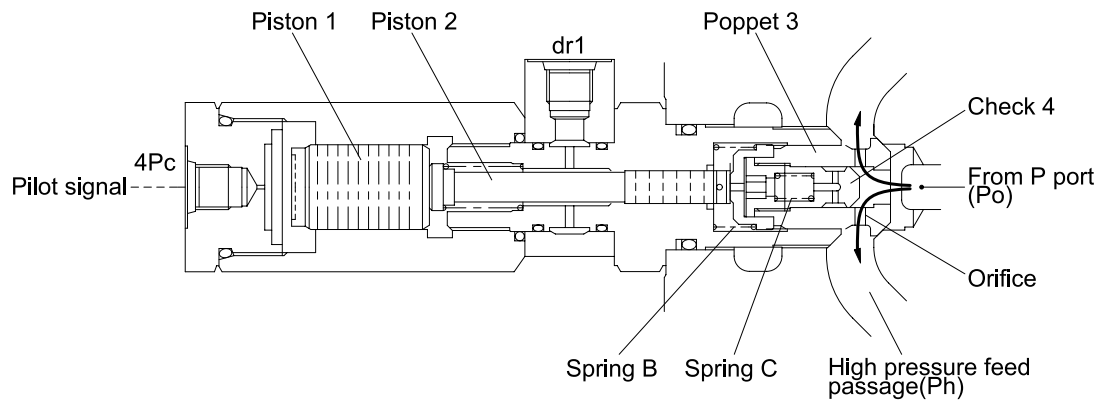

36072MC19

As the poppet(3) is forced to the body by the piston(1) and (2), oil from the P port pushes up the check(4) and flows into the high pressure feed passage of the swing through the orifice put on the poppet(3). Then oil from P port flows into the boom section prior to the swing section.

### (9) Arm load holding valve operation

When the plunger is in neutral (4Pi pilot signal : OFF)

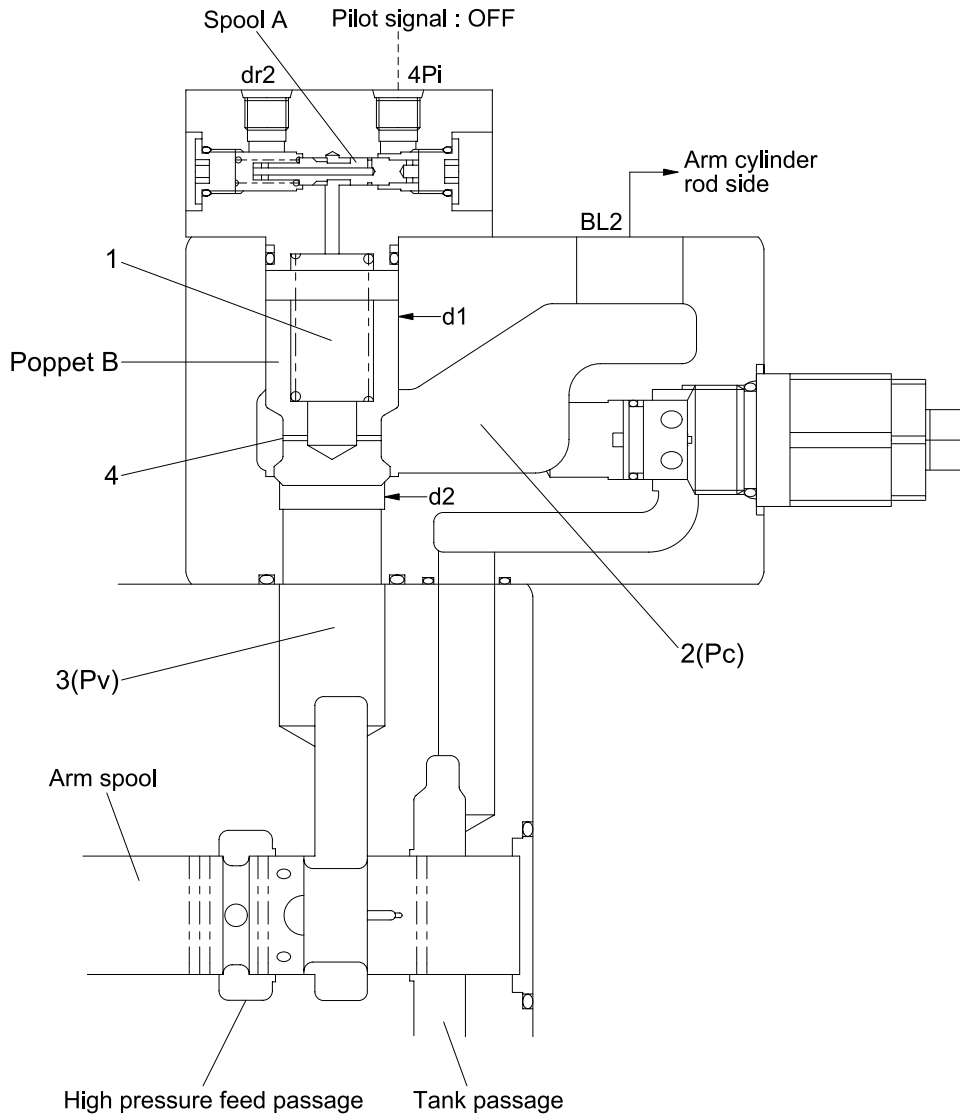

36072MC21

The spool(A) is in the status as shown. The passage from the chamber(1) to the drain port(dr2) is shut off by the spool(A). Therefore, the pressure of the chamber(1) is same to the pressure of Arm cylinder(rod); (equals to  $P_c$ ), as it is connected with the core(2) through the orifice(4) of the main poppet(B).

Since  $d_1 > d_2$ , the main poppet(B) is seated and the core(2) and (3) are completely blocked.

**When the plunger is operated**

**A. When  $P_c$  is lower than  $P_v$  (in the case of Arm OUT, 4Pi pilot signal : OFF)**

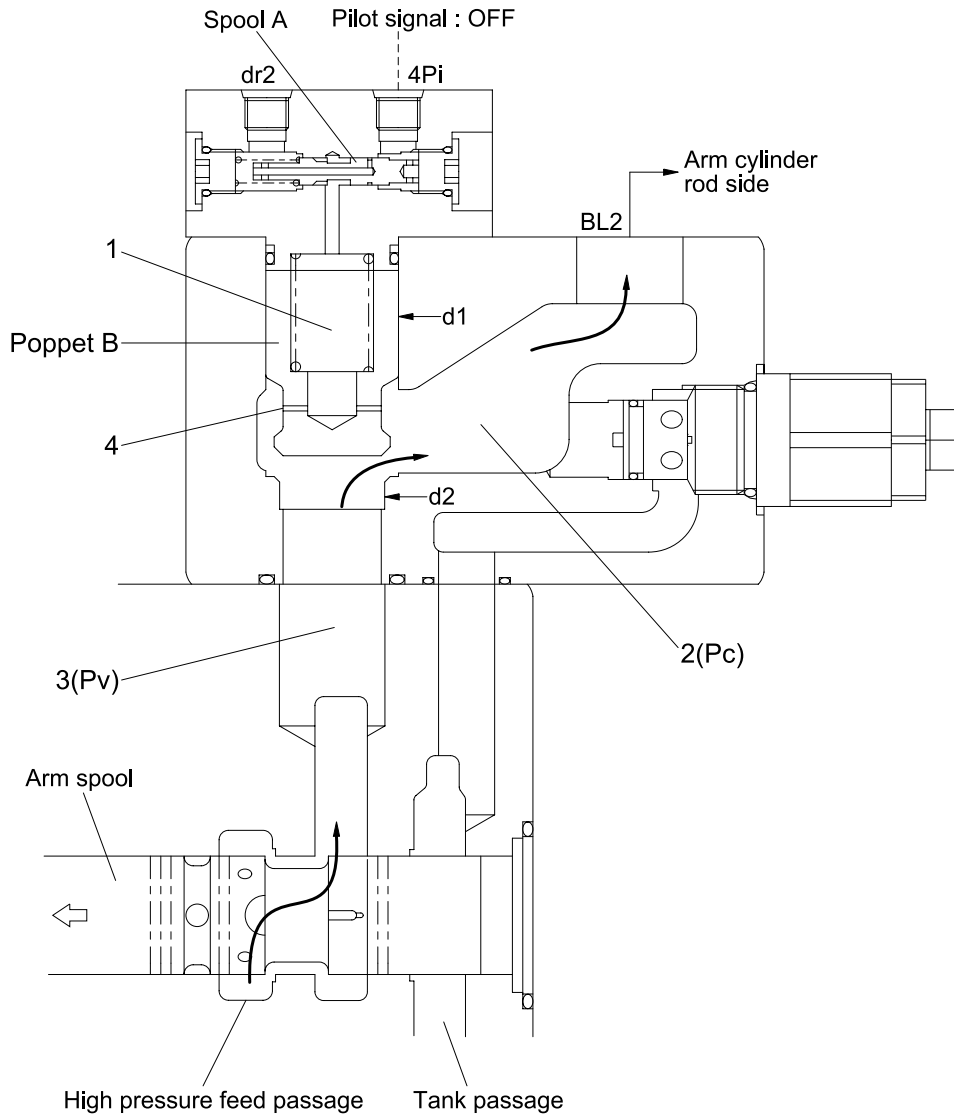

36072MC22

The pressure of the chamber(1) is same to the pressure of Arm cylinder(rod); (equals to  $P_c$ ), as it is connected with the core(2) through the orifice(4).

The main poppet(B) is pushed up and oil from the high pressure feed line flows into the Arm cylinder port.

**B. When  $P_c$  is higher than  $P_v$  (In case of Arm in, 4Pi pilot signal : ON)**

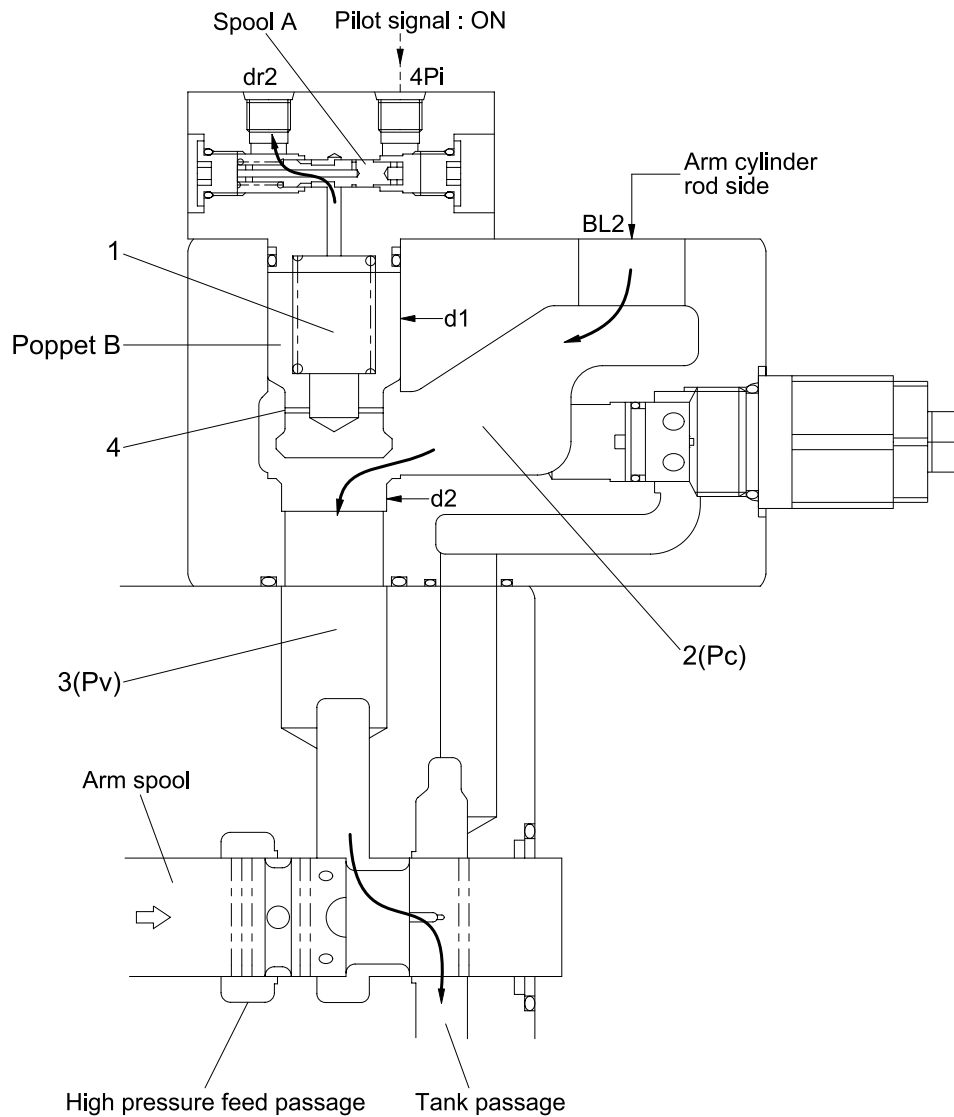

36072MC23

The spool(A) is switched by the pilot pressure, the chamber(1) is connected to the drain port(dr2). Then the pressure of the chamber(1) comes to lower than that of the core(2), and the pressure of the core(2) acts on the differential area( $d_1 - d_2$ ) to push up the main poppet(B). Return oil from Arm cylinder flows into the tank passage through the core(3) and around the main plunger.