

GROUP 9 STEERING VALVE

1. REMOVAL AND INSTALL

1) REMOVAL

- (1) Lower the work equipment to the ground and stop the engine.
- (2) Operate the control levers and pedals several times to release the remaining pressure in the hydraulic piping.
- (3) Loosen the breather slowly to release the pressure inside the hydraulic tank.
- ▲ Escaping fluid under pressure can penetrate the skin causing serious injury.
- (4) Disconnect steering line hoses(3).
- (5) Loosen the hexagon bolt(2) and remove the steering valve assembly(1).
 - Tightening torque : $4.8 \pm 0.3 \text{kgf} \cdot \text{m}$
($34.7 \pm 2.2 \text{lb} \cdot \text{ft}$)

2) INSTALL

- (1) Carry out installation in the reverse order to removal.
- (2) Confirm the hydraulic oil level and check the hydraulic oil leak or not.
When removing the steering valve assembly, check that all the hoses have been disconnected.

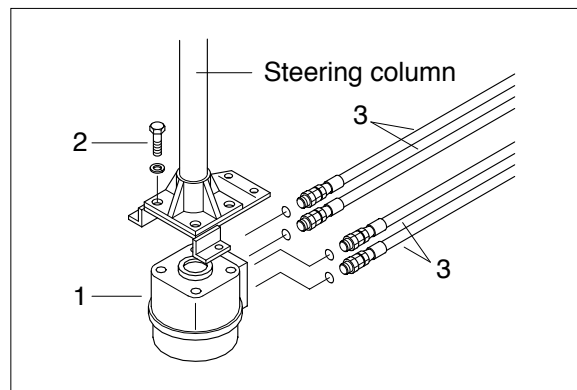

2. STEERING VALVE

1) STRUCTURE

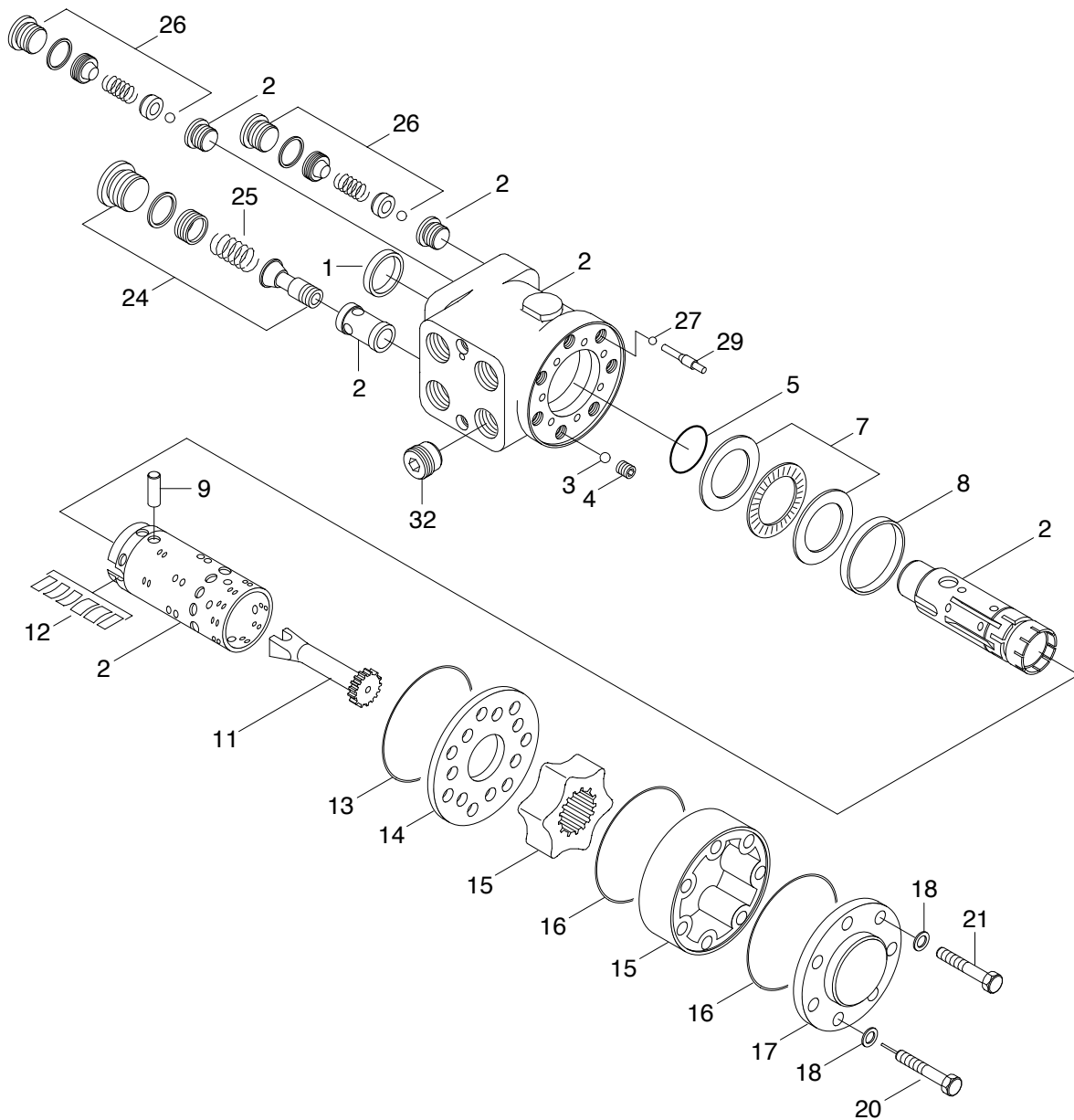

1	Dust seal ring	12	Spring set	22	Name plate
2	*Housing assy	13	O-ring	23	Drive screw
3	Ball	14	Distributor plate	24	Pressure relief valve
4	Bushing	15	Gearwheel set	25	Wire spring
5	O-ring	16	O-ring	26	Shock valve
7	Bearing assy	17	End cover	27	Ball
8	Ring	18	Washer	29	Bushing
9	Cross pin	20	Pin screw	32	Check valve
11	Shaft	21	Screw		

* Housing, spool and sleeve(Check valve and the seats for relief and dual shock valves are loctited).

2) TOOLS

(1) Holding tool.

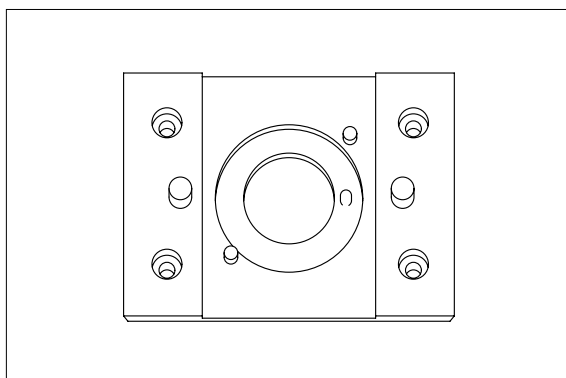

(2) Assembly tool for O-ring(5,13,16) and kin-
ring(6).

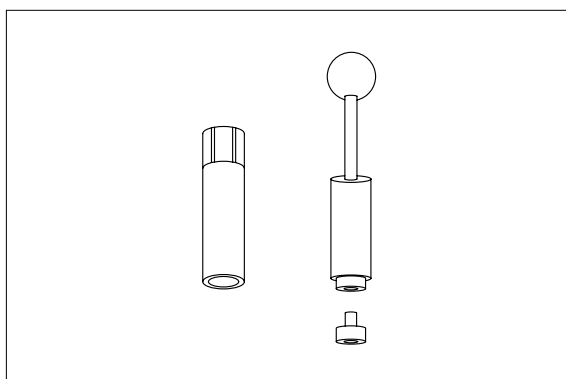

(3) Assembly tool for cardan shaft(11).

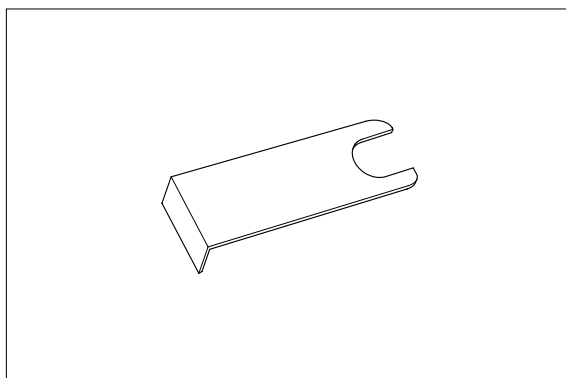

(4) Assembly tool for dust seal(1).

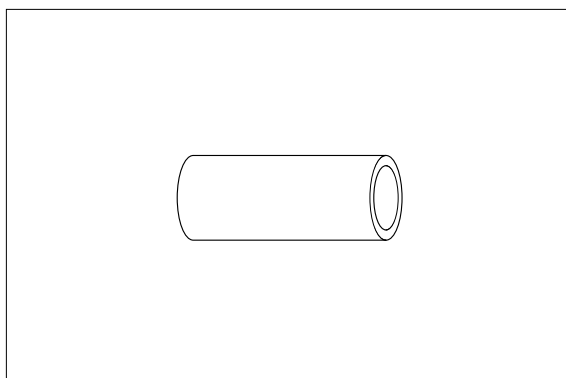

- (5) Torque wrench : 0~7.1kgf · m
(0~54.4lbf · ft).
- 13mm socket spanner.
 - 6, 8mm and 12mm hexagon sockets.
 - 12mm screwdriver.
 - 2mm screwdriver.
 - 13mm ring spanner.
 - 6, 8mm and 12mm hexagon socket spanners.
 - Plastic hammer.
 - Tweezers.

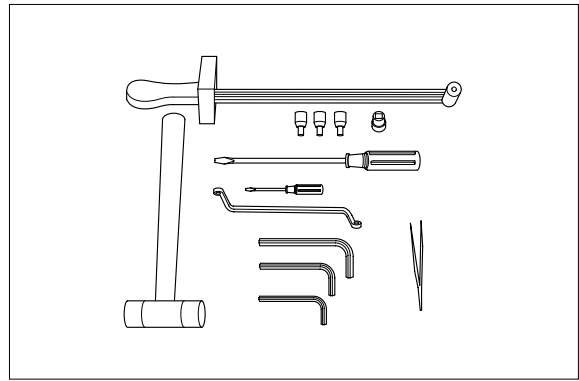

3) TIGHTENING TORQUE AND HYDRAULIC CONNECTIONS

(1) Hydraulic connections

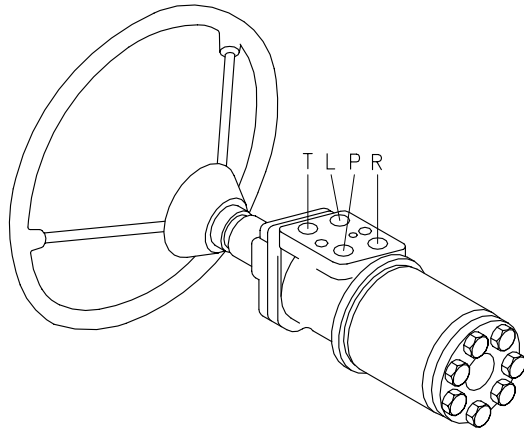

L : Left port
 R : Right port
 T : Tank
 P : Pump

(2) Tightening torque

Screwed connection	Max. tightening torque [kgf · m (lbf · ft)]			
	With cutting edge	With copper washer	With aluminum washer	With O-ring
1.4 BSP.F	4.1(29.7)	2.0(14.5)	3.1(22.4)	-
3/8 BSP.F	6.1(44.1)	2.0(14.5)	5.1(36.9)	-
1/2 BSP.F	10.2(73.8)	3.1(22.4)	8.2(59.3)	-
7/16-20 UNF	-	-	-	2.0(14.5)
3/4-16 UNF	-	-	-	6.1(44.1)
M12 × 1.5	4.1(29.7)	2.0(14.5)	3.1(22.4)	2.0(14.5)
M18 × 1.5	7.1(51.4)	2.0(14.5)	5.1(36.9)	5.1(36.9)
M22 × 1.5	10.2(73.8)	3.1(22.4)	8.2(59.3)	7.1(51.4)

4) DISASSEMBLY

- (1) Disassemble steering column from steering valve and place the steering valve in the holding tool.
Screw out the screws in the end cover(6-off plus one special screw).

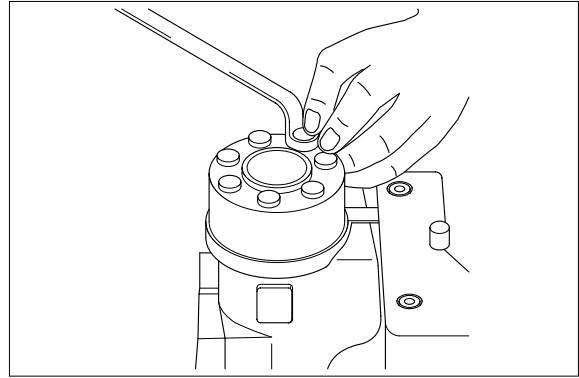

- (2) Remove the end cover, sideways.

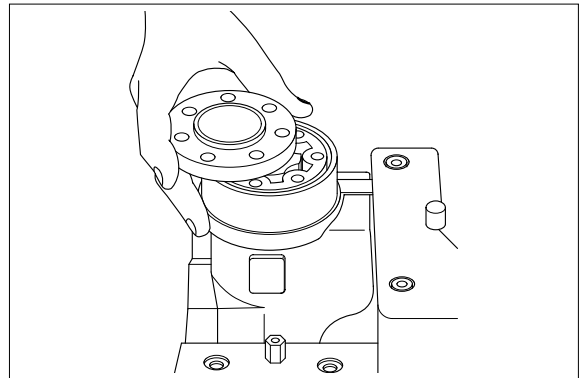

- (3) Lift the gearwheel set(with spacer if fitted) off the unit.
Take out the two O-rings.

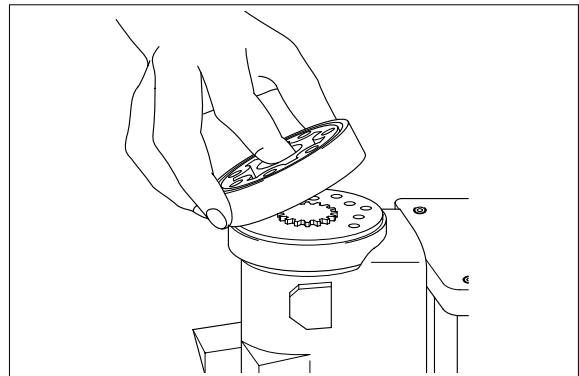

- (4) Remove cardan shaft.

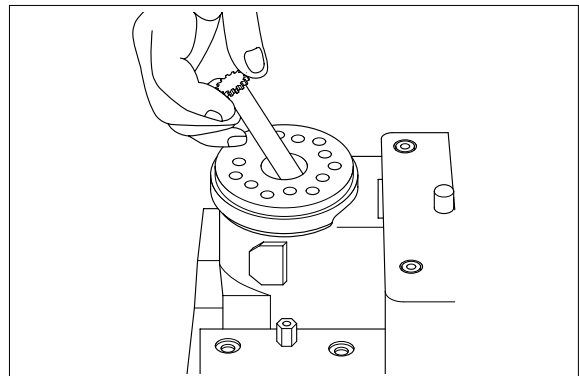

(5) Remove distributor plate.

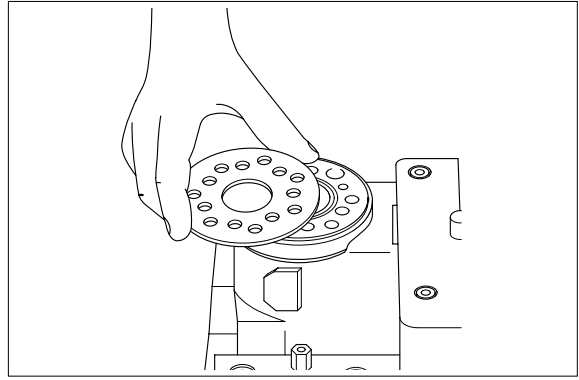

(6) Screw out the threaded bush over the check valve.

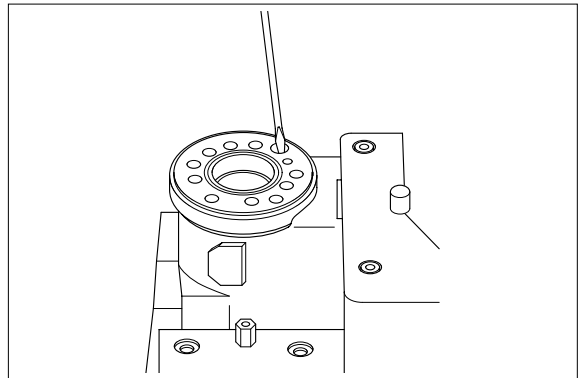

(7) Remove O-ring.

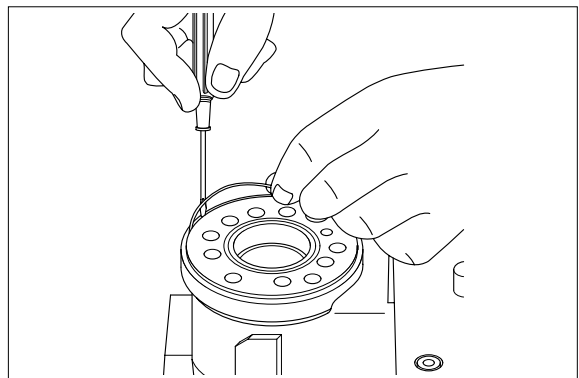

(8) Shake out the check valve ball and suction valve pins and balls.

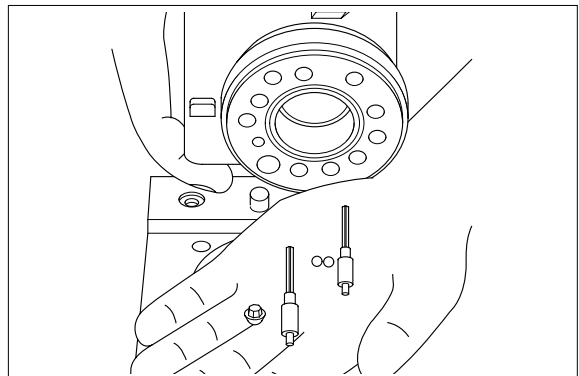

- (9) Take care to keep the cross pin in the sleeve and spool horizontal. The pin can be seen through the open end of the spool. Press the spool inwards and the sleeve, ring, bearing races and needle bearing will be pushed out of the housing together.

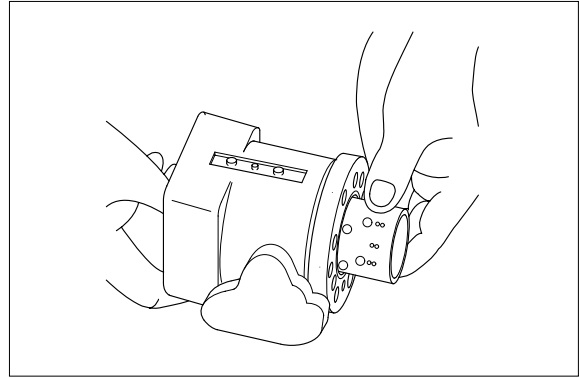

- (10) Take ring, bearing races and needle bearing from sleeve and spool. The outer(thin) bearing race can sometimes "stick" in the housing, therefore check that it has come out.

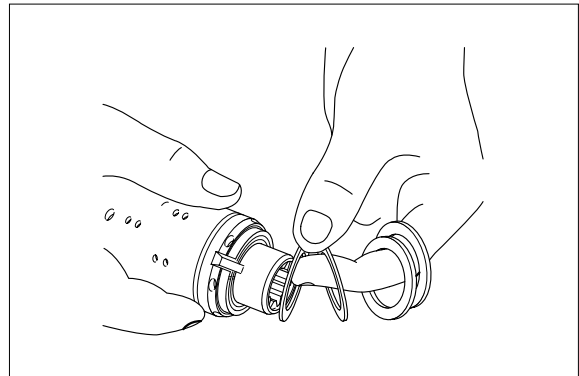

- (11) Press out the cross pin. Use the special screw from the end cover.

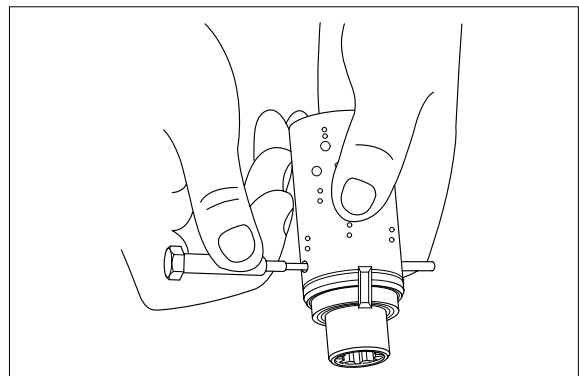

A small mark has been made with a pumice stone on both spool and sleeve close to one of the slots for the neutral position spring as figure.

If the mark is not visible, remember to leave a mark of your own on sleeve and spool before the neutral position springs are disassembled.

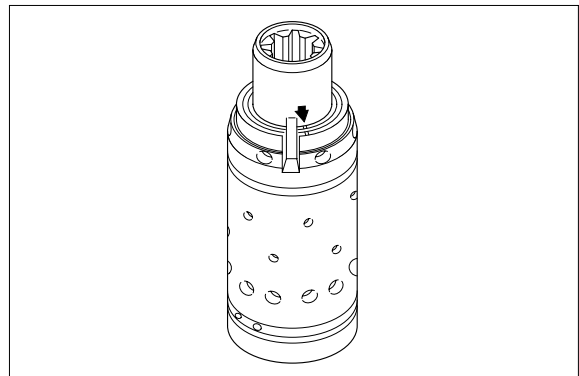

(12) Carefully press the spool out of the sleeve.

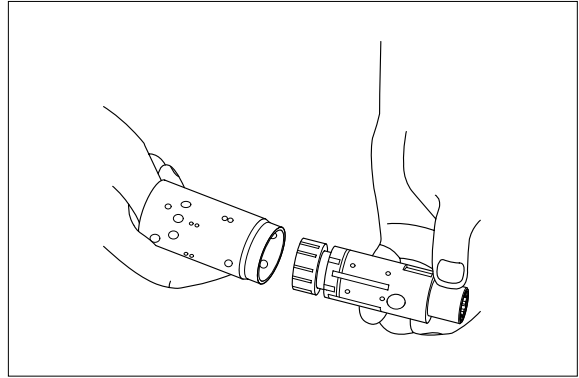

(13) Press the neutral position springs out of their slots in the spool.

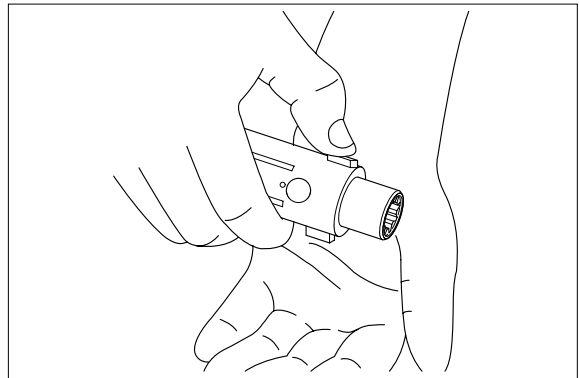

(14) Remove dust seal and O-ring.

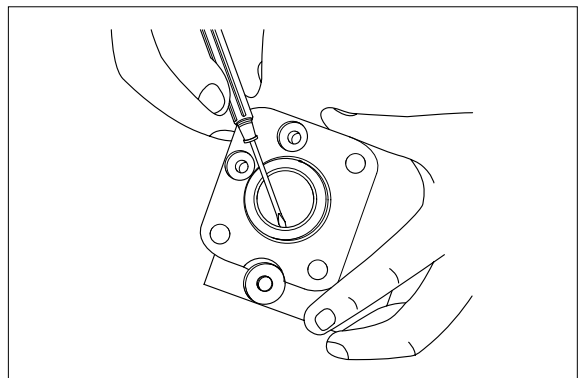

(15) Disassemble the dual shock valve

Remove plugs from shock valves using a 6mm hexagon socket spanner.

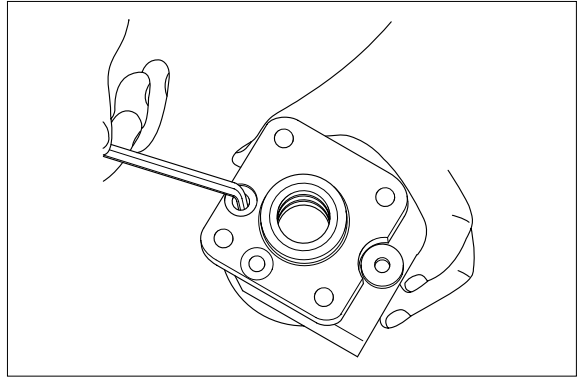

Remove seal washers(2-off).

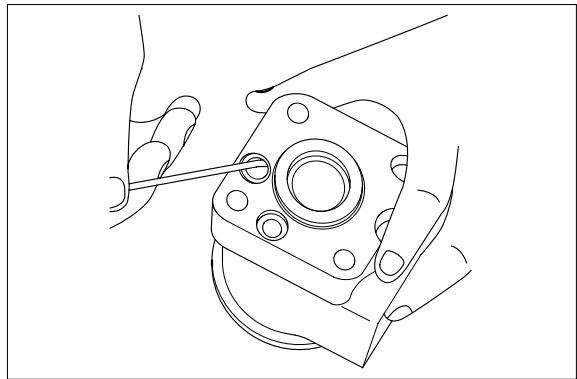

Unscrew the setting screws using a 6mm hexagon socket spanner.

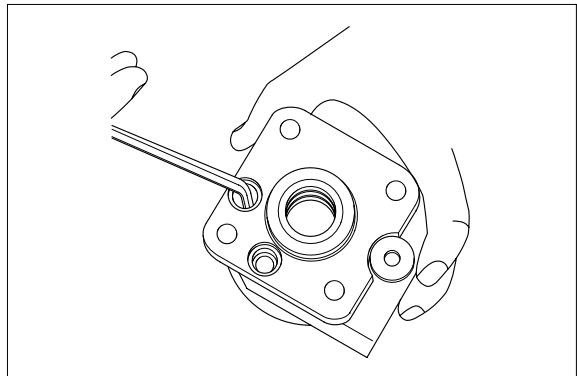

Shake out the two springs and two valve balls into your hand. The valve seats are bonded into the housing and cannot be removed.

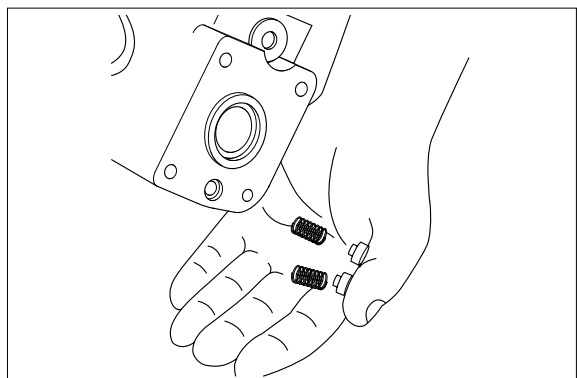

The dual shock valves are now disassembled.

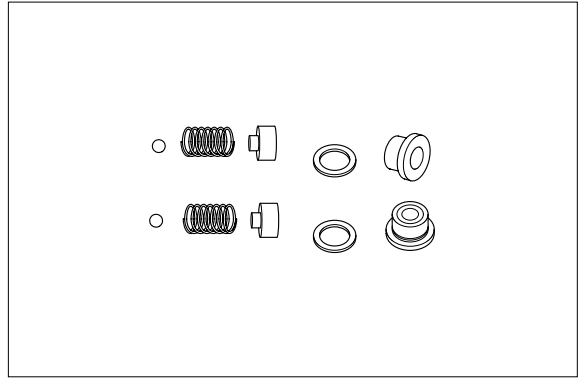

(16) Disassemble the pressure relief valve (Cartridge)

Screw out the plug using an 8mm hexagon socket spanner. Remove seal washers.

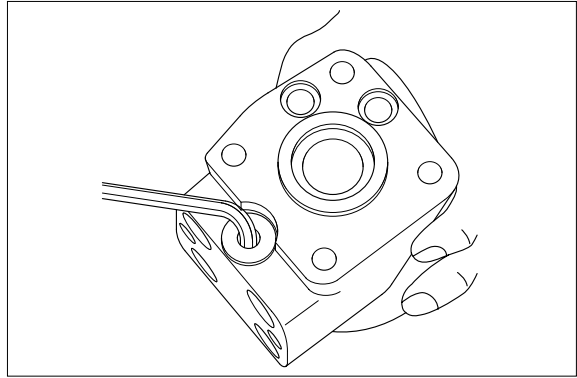

Unscrew the setting screw using an 8mm hexagon socket spanner.

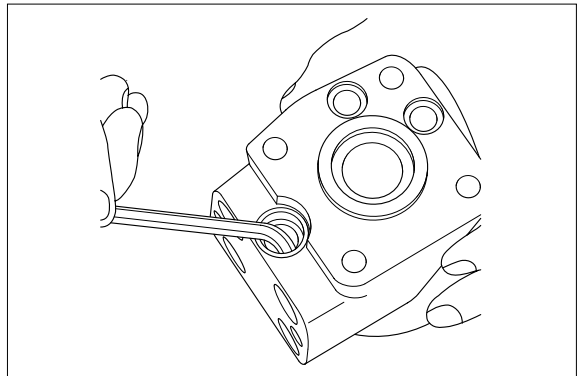

Shake out spring and piston. The valve seat is bonded into the housing and cannot be removed.

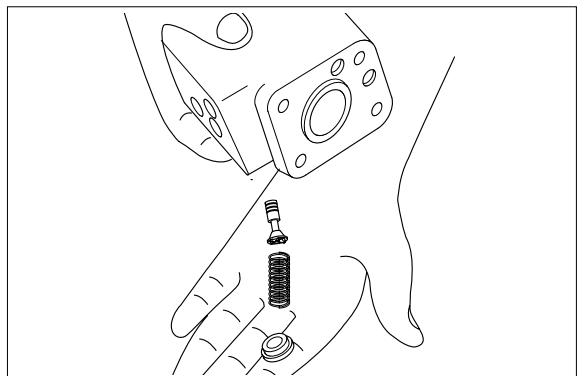

The pressure relief valve is now disassembled.

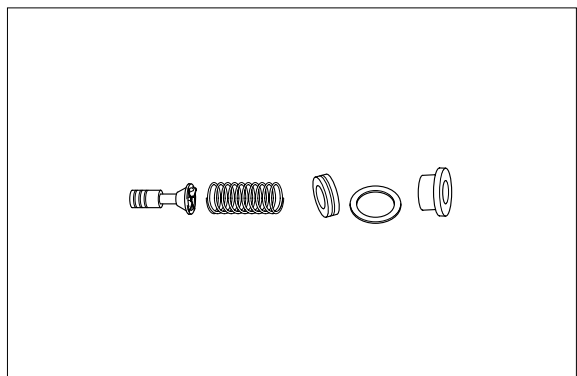

The steering valve is now completely disassembled.

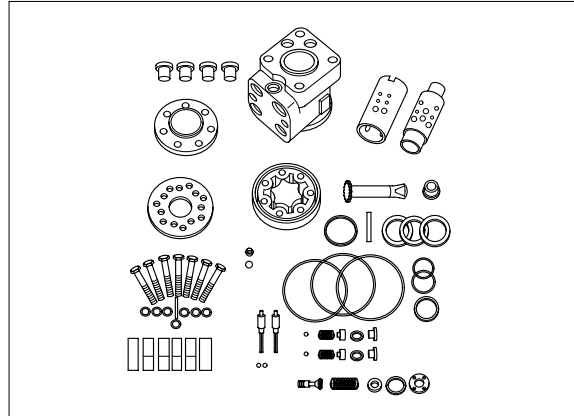

Cleaning

Clean all parts carefully in shellsol K or the like.

Inspection and replacement

Replace all seals and washers. Check all parts carefully and make any replacements necessary.

Lubrication

Before assembly, lubricate all parts with hydraulic oil.

5) ASSEMBLY

(1) Assemble spool and sleeve.

When assembling spool and sleeve only one of two possible ways of positioning the spring slots is correct. There are three slots in the spool and three holes in the sleeve in the end of the spool / sleeve opposite to the end with spring slots.

Place the slots and holes opposite each other so that parts of the holes in the sleeve are visible through the slots in the spool.

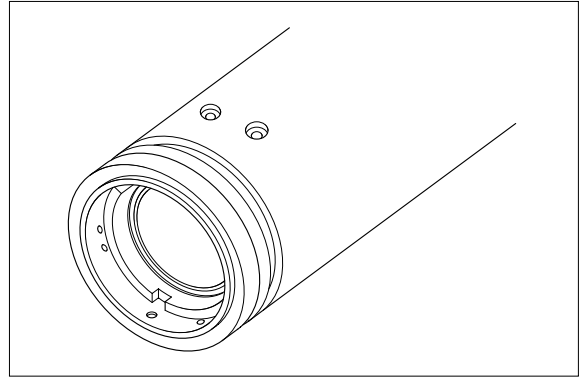

(2) Place the two flat neutral position springs in the slot.

Place the curved springs between the flat ones and press them into place(see assembly pattern).

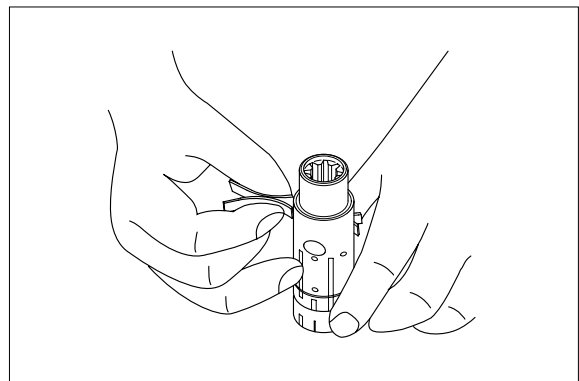

Assembly pattern.

· Part no : 150N4035

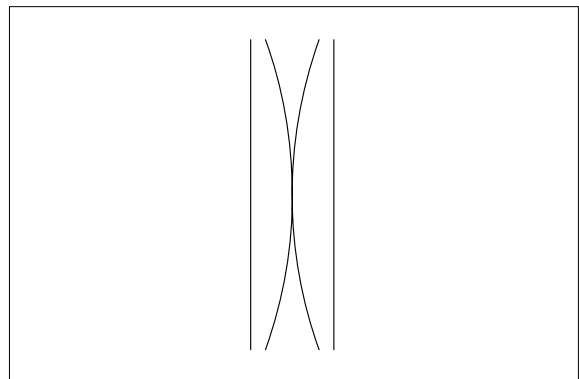

(3) Line up the spring set.

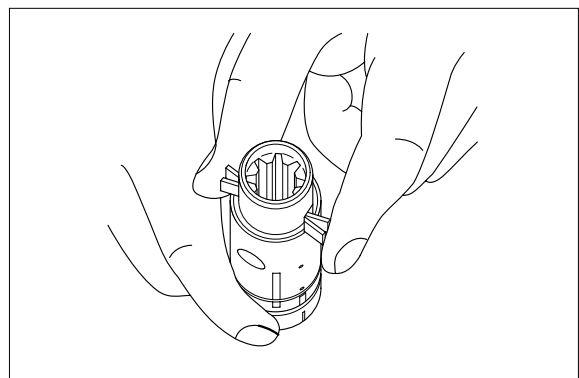

- (4) Guide the spool into the sleeve. Make sure that spool and sleeve are placed correctly in relation to each other.

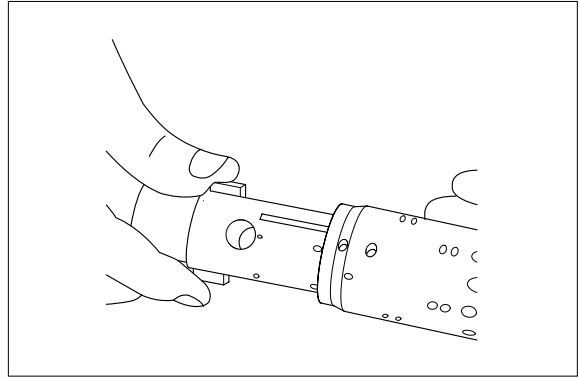

- (5) Press the springs together and push the neutral position springs into place in the sleeve.

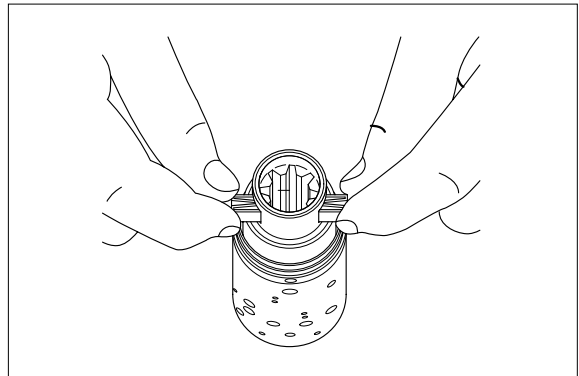

- (6) Line up the springs and center them.

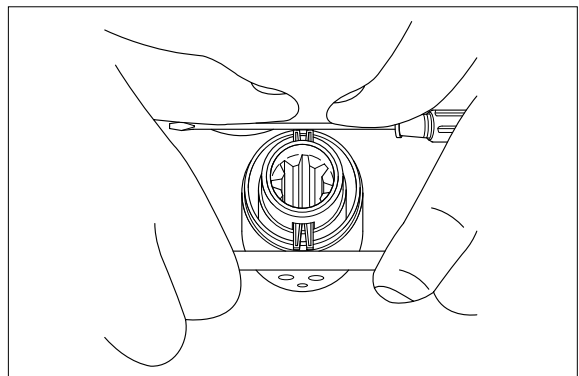

- (7) Guide the ring down over the sleeve. The ring should be able to rotate free of the springs.

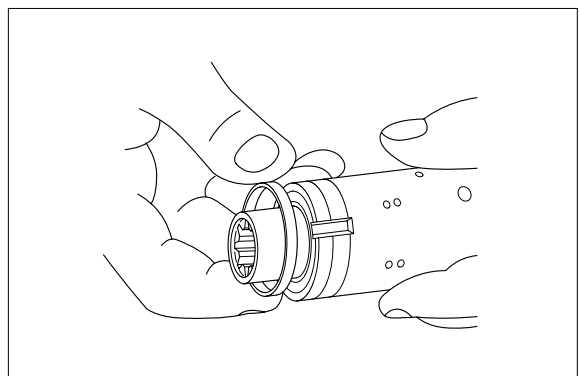

(8) Fit the cross pin into the spool / sleeve.

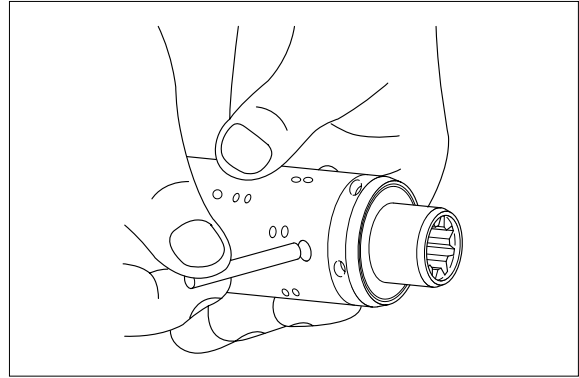

(9) Fit bearing races and needle bearing as shown on below drawing.

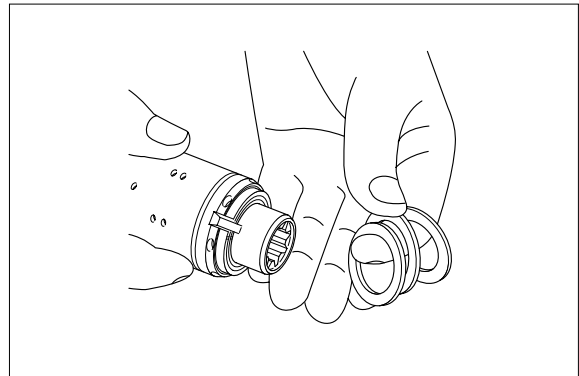

Assembly patted for standard bearings

- 1 Outer bearing race
- 2 Needle bearing
- 3 Inner bearing race
- 4 Spool
- 5 Sleeve

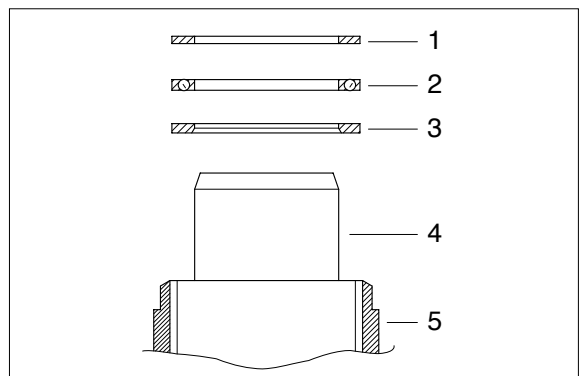

Installation instruction for O-ring

(10) Turn the steering unit until the bore is horizontal. Guide the outer part of the assembly tool into the bore for the spool / sleeve.

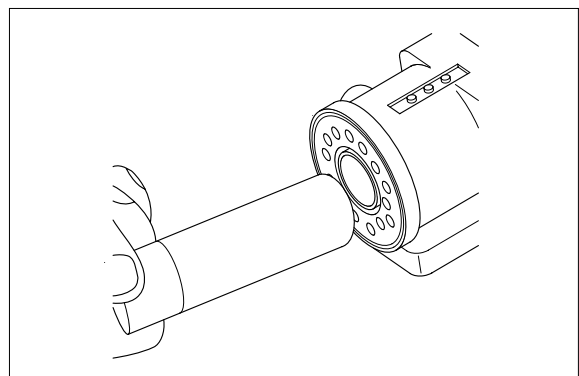

(11) Grease O-ring with hydraulic oil and place them on the tool.

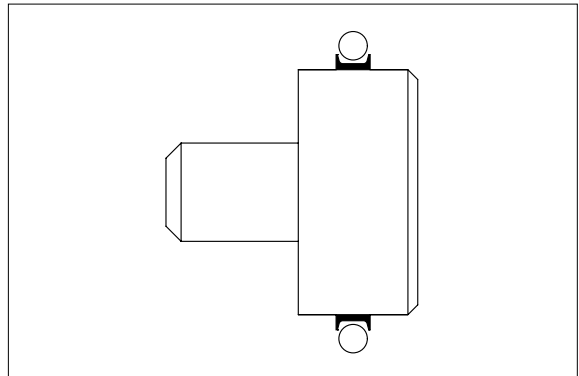
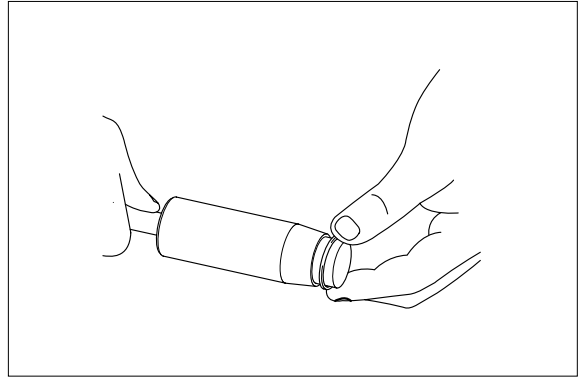

(12) Hold the outer part of the assembly tool in the bottom of the steering unit housing and guide the inner part of the tool right to the bottom.

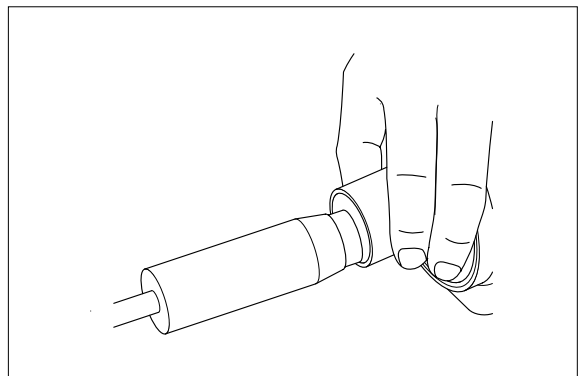

(13) Press and turn the O-ring into position in the housing.

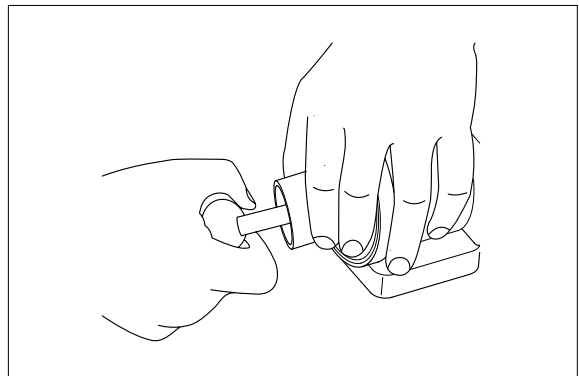

- (14) Draw the inner and outer parts of the assembly tool out of the steering unit bore, leaving the guide from the inner part in the bore.

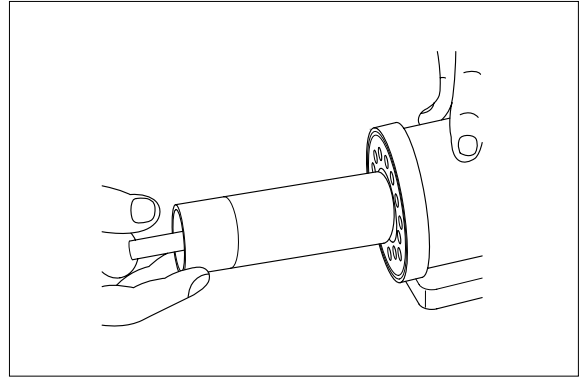

- (15) With a light turning movement, guide the spool and sleeve into the bore. Fit the spool set holding the cross pin horizontal.

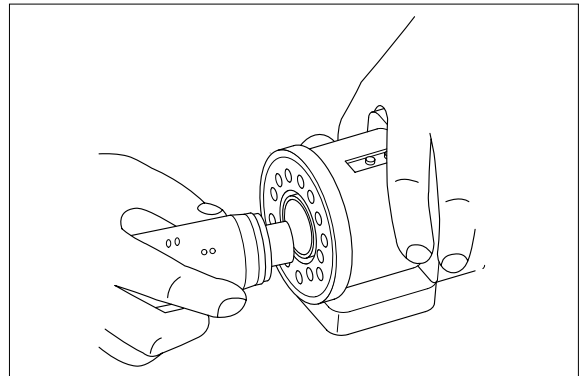

- (16) The spool set will push out the assembly tool guide. The O-ring is now in position.

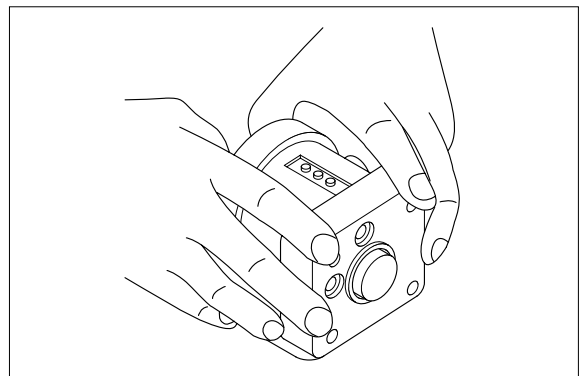

- (17) Turn the steering unit until the bore is vertical again. Put the check valve ball into the hole indicated by the arrow.

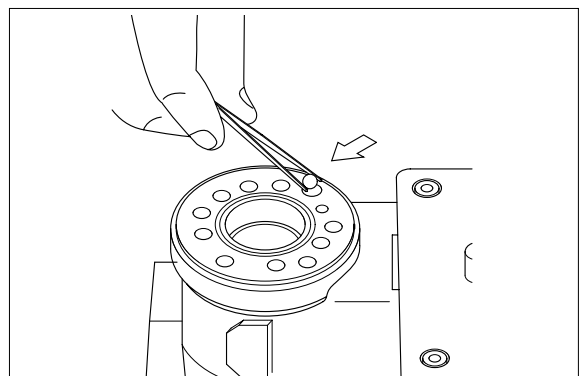

(18) Screw the threaded bush lightly into the check valve bore. The top of the bush must lie just below the surface of the housing.

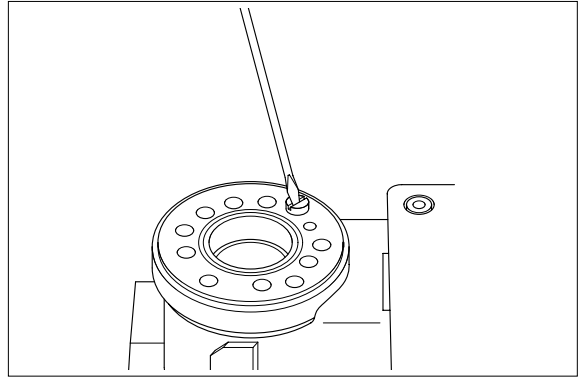

Assembly of the two suction valve

(19) Place a ball in the two holes indicated by the arrows.

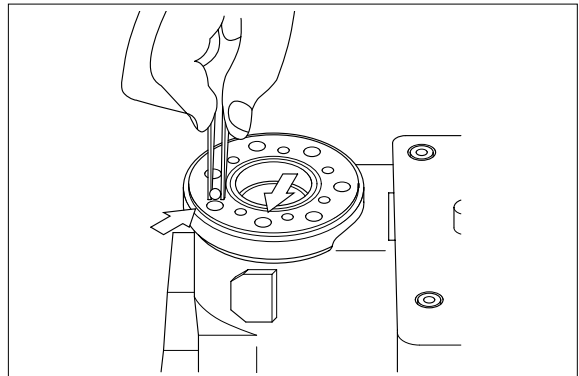

(20) Place a pin in the same two holes.

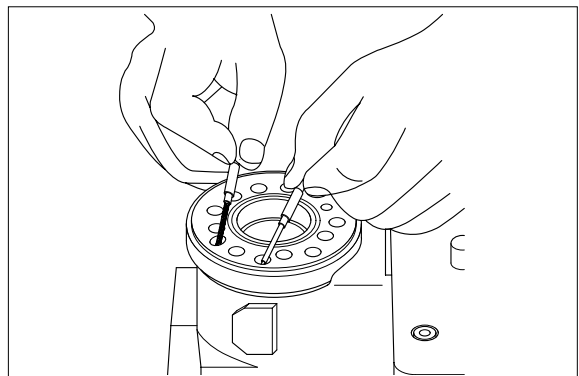

(21) In some cases a spring has to be fitted on the pin before it is placed in the housing.

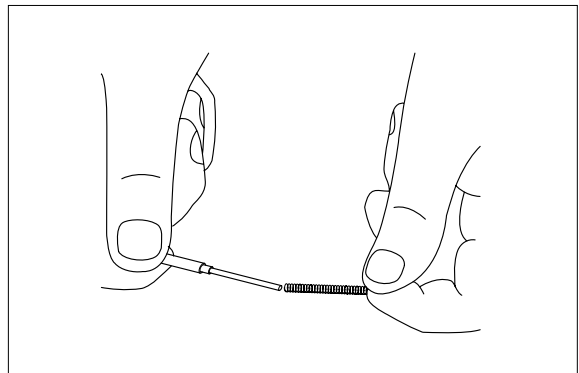

(22) Grease the O-ring with mineral oil approx viscosity 500 cST at 20°C.

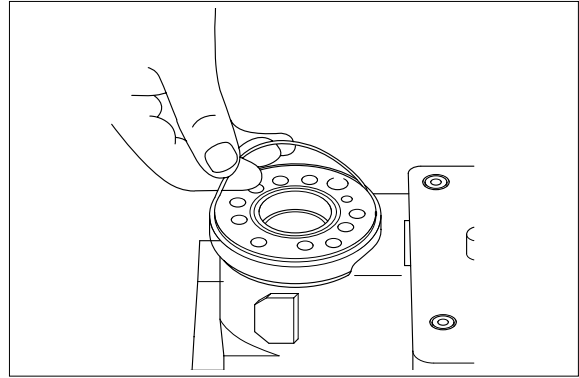

(23) Place the distributor plate so that the channel holes match the holes in the housing.

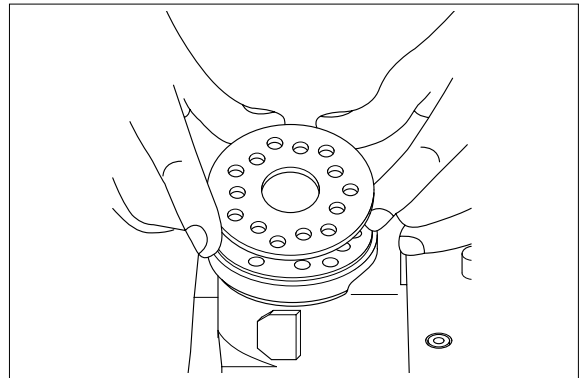

(24) Guide the cardan shaft down into the bore so that the slot is parallel with the connection flange.

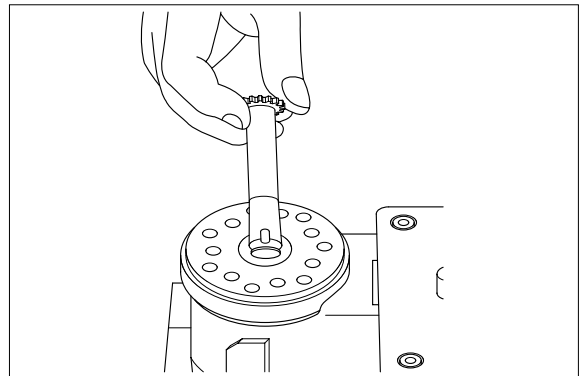

(25) Place the cardan shaft as shown so that it is held in position by the mounting fork.

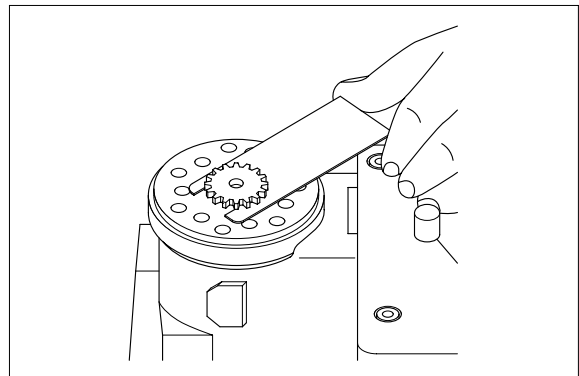

(26) Grease the two O-rings with mineral oil approx. viscosity 500 cST at 20°C and place them in the two grooves in the gear rim. Fit the gearwheel and rim on the cardan shaft.

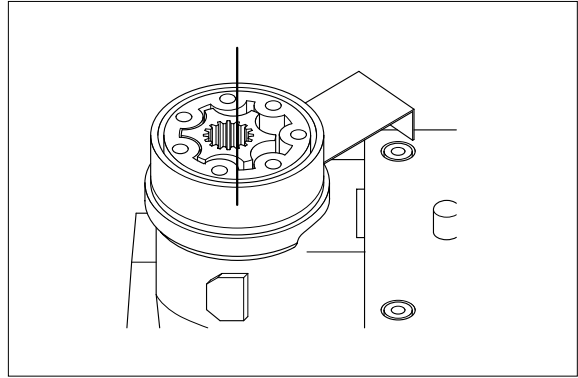

(27) Fit the gearwheel(rotor) and cardan shaft so that a tooth base in the rotor is positioned in relation to the shaft slot as shown. Turn the gear rim so that the seven through holes match the holes in the housing.

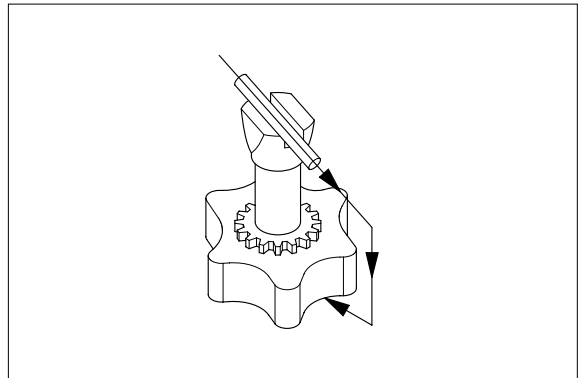

(28) Fit the spacer, if any.

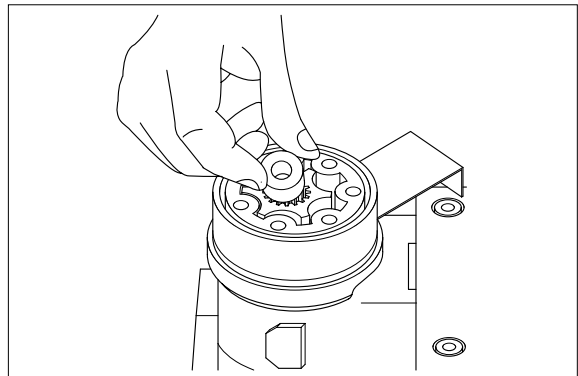

(29) Place the end cover in position.

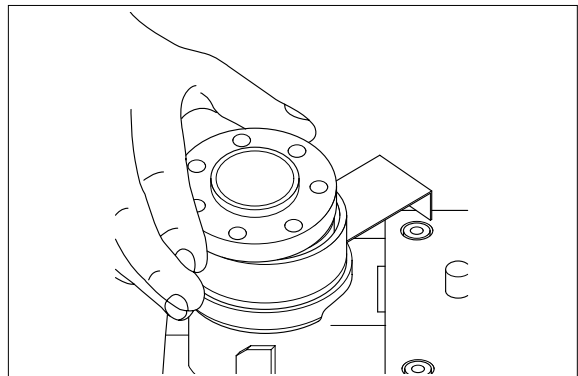

- (30) Fit the special screw with washer and place it in the hole shown.

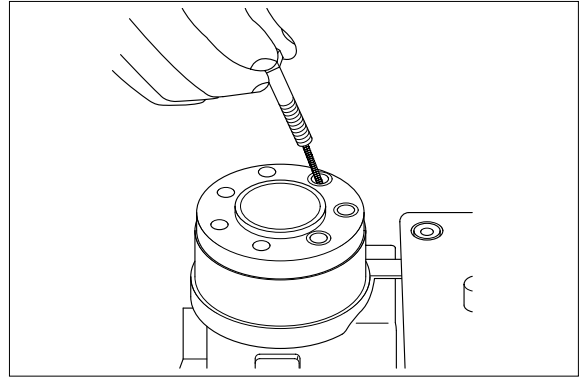

- (31) Fit the six screws with washers and insert them. Cross-tighten all the screws and the rolled pin.

- tightening torque : $3.0 \pm 0.6 \text{ kgf} \cdot \text{m}$
($22.4 \pm 4.3 \text{ lbf} \cdot \text{ft}$)

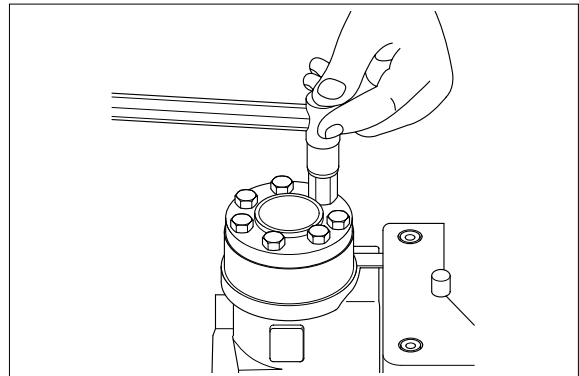

- (32) Place the dust seal ring in the housing.
The dust seal ring must be placed only after the pressure relief valve and shock valves have been fitted.

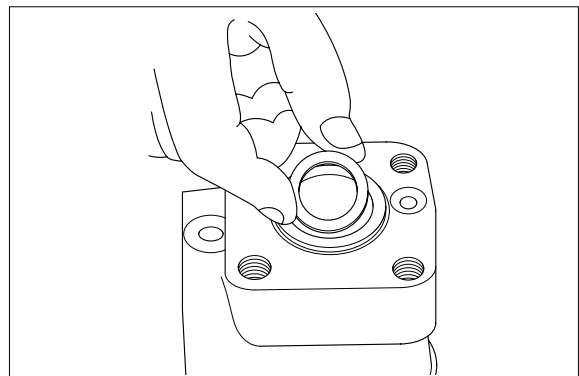

- (33) Fit the dust seal ring in the housing.

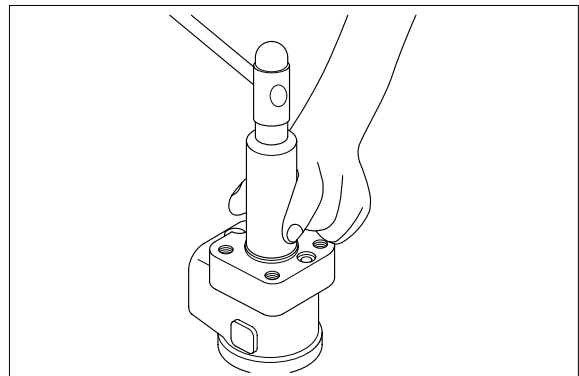

- (34) Press the plastic plugs into the connection ports.
Do not use a hammer!

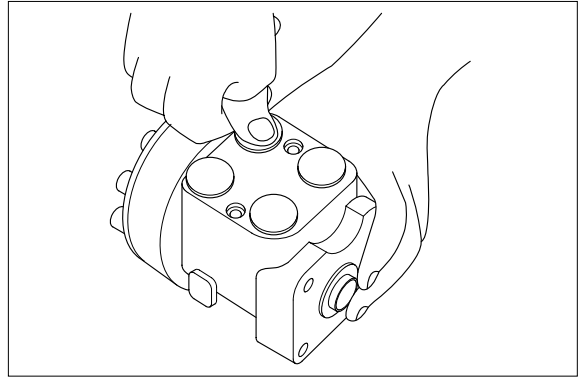

Assembly of the pressure relief valve

- (35) Fit the piston.

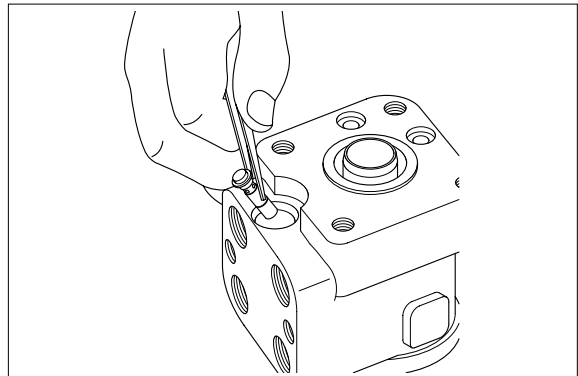

- (36) Fit the spring.

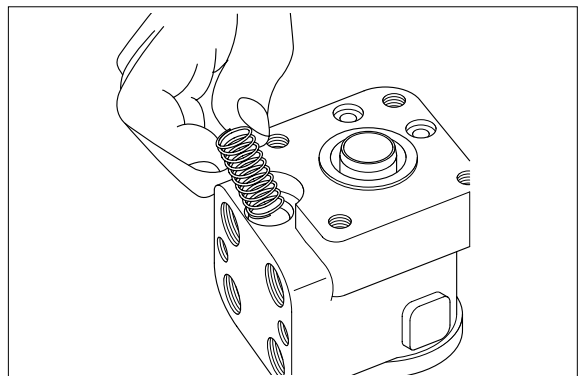

- (37) Screw in the setting screw with an 8mm hexagon socket spanner. Make the pressure setting on a panel or the machine.

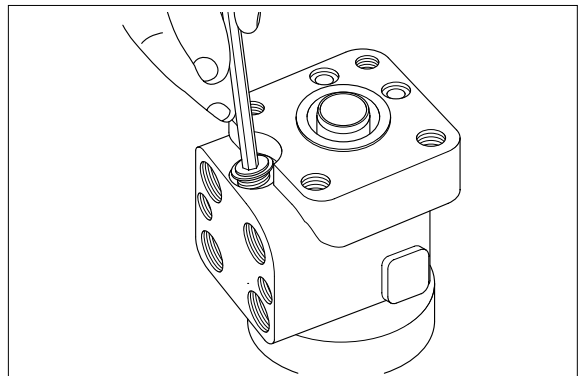

- (38) Screw plug with dust seal into the housing using an 8mm hexagon socket spanner.
- tightening torque : $5.1 \pm 1 \text{ kgf} \cdot \text{m}$
($36.9 \pm 7.2 \text{ lbf} \cdot \text{ft}$)

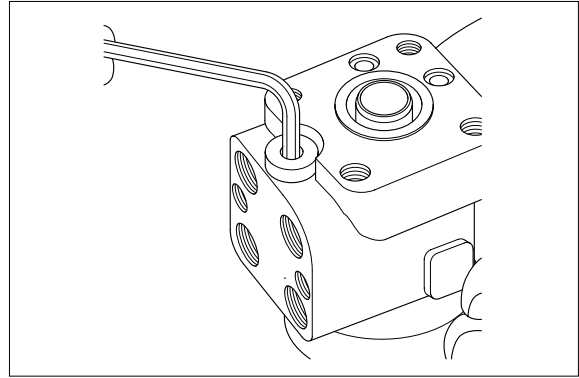

Assembly of the dual shock valve

- (39) Put a ball in the two holes indicated by the arrows.

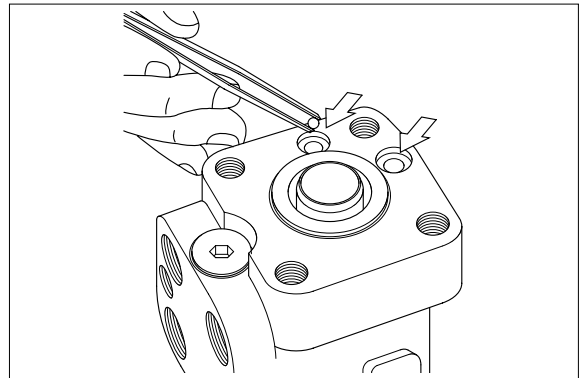

- (40) Place springs and valve cones over the two balls.

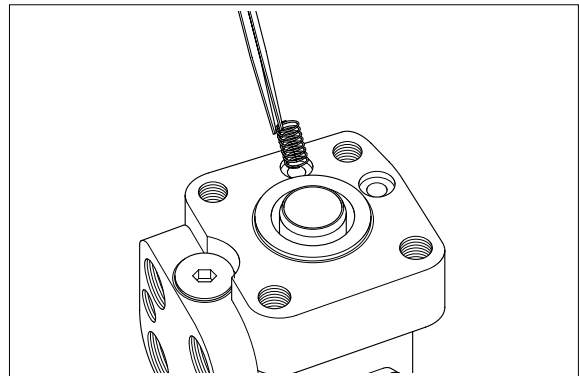

- (41) Screw in the two setting screws using a 6mm hexagon socket spanner. Make the pressure setting on a panel or the machine.

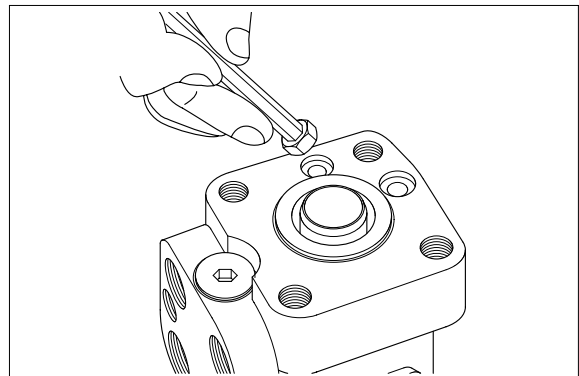

- (42) Screw plug with seal ring into the two shock valves using a 6mm hexagon socket spanner.
- Tightening torque : 3.1kgf · m(22.4lbf · ft)

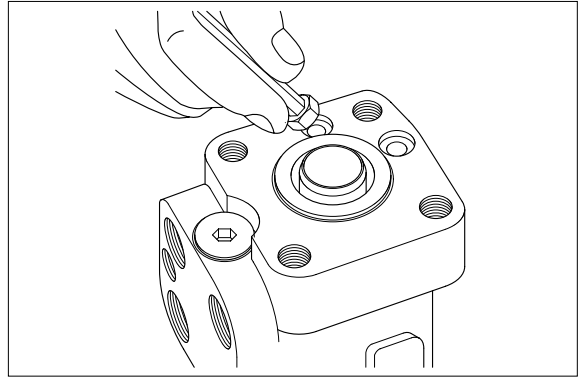

Steering valve is now assembled.