

GROUP 14 WORK EQUIPMENT

1. STRUCTURE

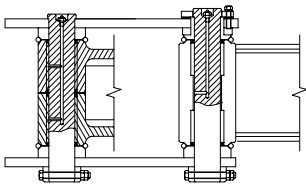

Section A

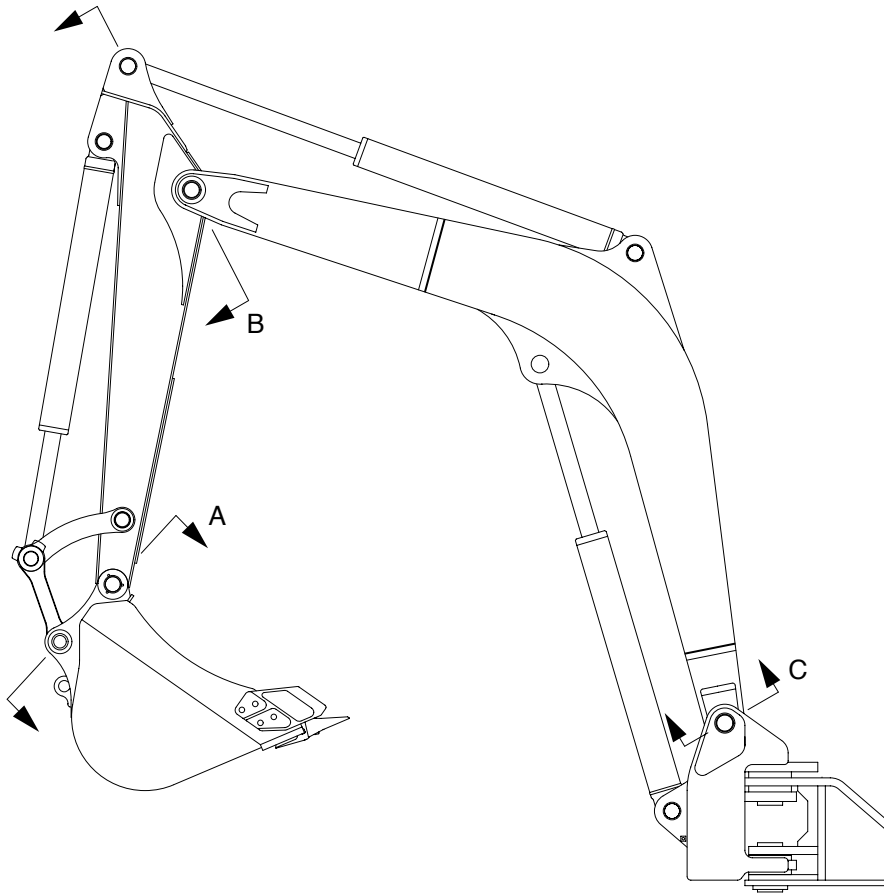
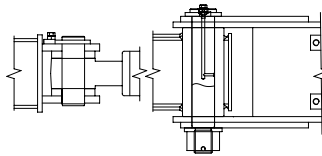

Section B

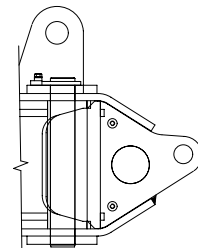

Section C

2. REMOVAL AND INSTALL

1) BUCKET ASSEMBLY

(1) Removal

Lower the work equipment completely to ground with back of bucket facing down.

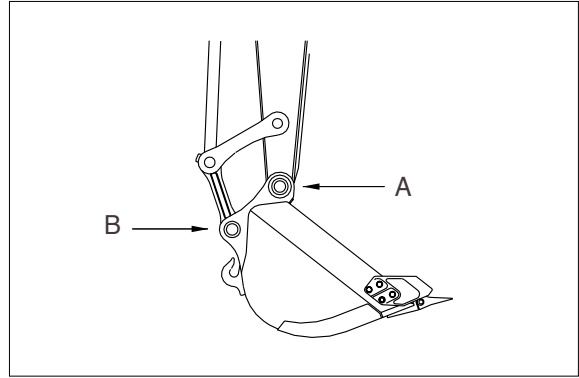

Remove nut(4), bolt(3) and draw out the pin(1).

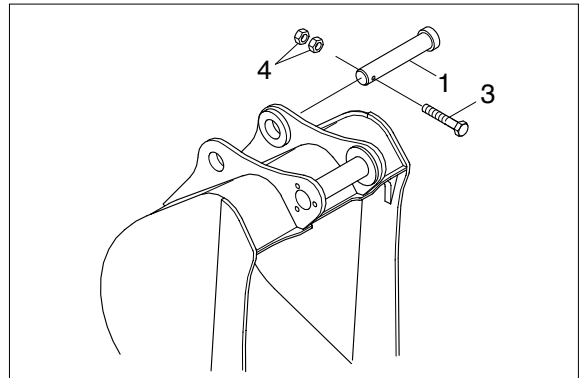

Remove nut(6), bolt(5) and draw out the pin(2).

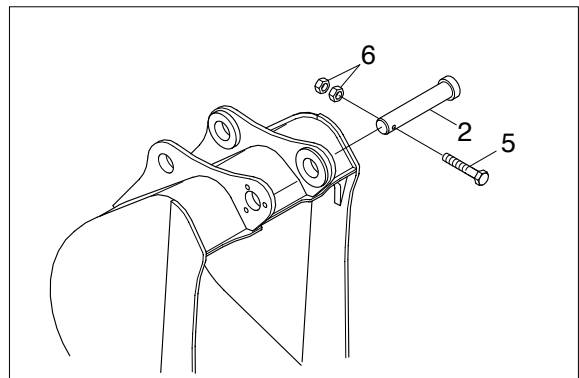

(2) Install

Carry out installation in the reverse order to removal.

- ▲ When aligning the mounting position of the pin, do not insert your fingers in the pin hole.

Adjust the bucket clearance.

For detail, see **operation manual**.

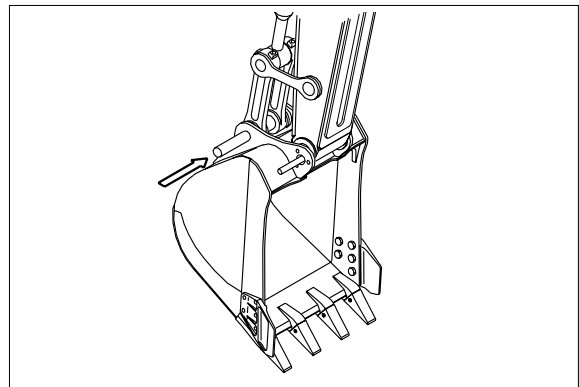

2) ARM ASSEMBLY

(1) Removal

Operate the control levers and pedals several times to release the remaining pressure in the hydraulic piping.

Loosen the breather slowly to release the pressure inside the hydraulic tank.

⚠ Escaping fluid under pressure can penetrate the skin causing serious injury.

Remove bucket assembly.

For details, see **removal of bucket assembly**.

Disconnect bucket cylinder hose(1).

⚠ Fit blind plugs in the piping at the chassis end securely to prevent oil from spurting out when the engine is started.

Sling arm cylinder assembly, remove spring, pin stopper and pull out pin.

Tie the rod with wire to prevent it from coming out.

For details, see **removal of arm cylinder assembly**.

Place a wooden block under the cylinder and bring the cylinder down to it.

Remove bolt(4), plate(3), split pin(5), slotted nut(6) and pull out the pin(2) then remove the arm assembly.

· Weight : 360kg(7900lb)

When lifting the arm assembly, always lift the center of gravity.

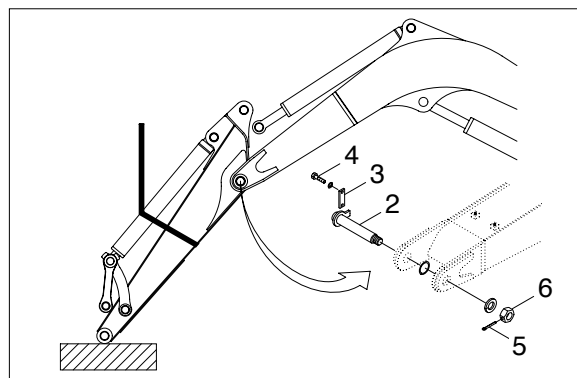
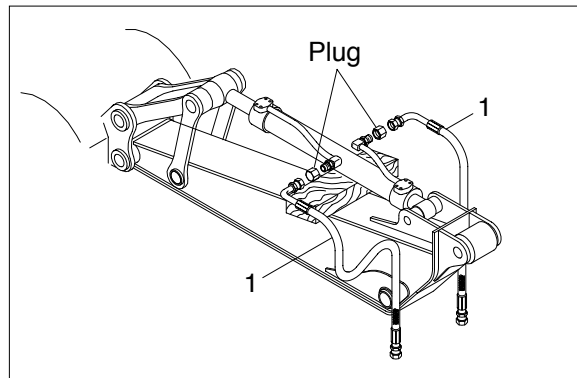
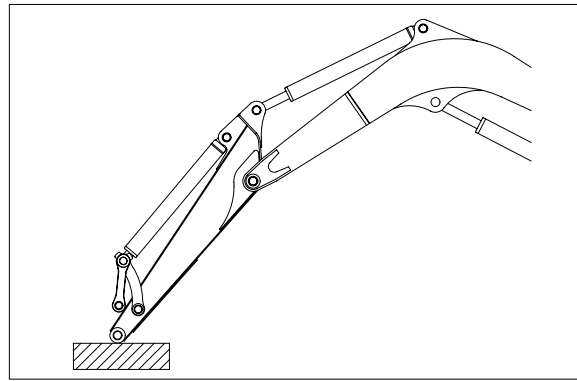

(2) Install

Carry out installation in the reverse order to removal.

⚠ When lifting the arm assembly, always lift the center of gravity.

Bleed the air from the cylinder.

3) BOOM ASSEMBLY

(1) Removal

Remove arm and bucket assembly.

For details, see **removal of arm and bucket assembly**.

Remove boom cylinder assembly from boom.

For details, see **removal of boom cylinder assembly**.

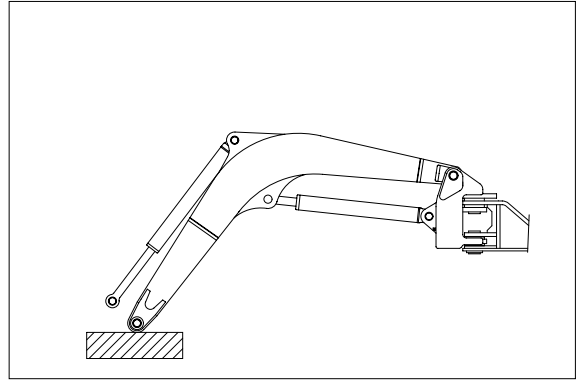

Disconnect head lamp wiring.

Disconnect bucket cylinder hose(2) and arm cylinder hose(1).

When the hose are disconnected, oil may spurt out.

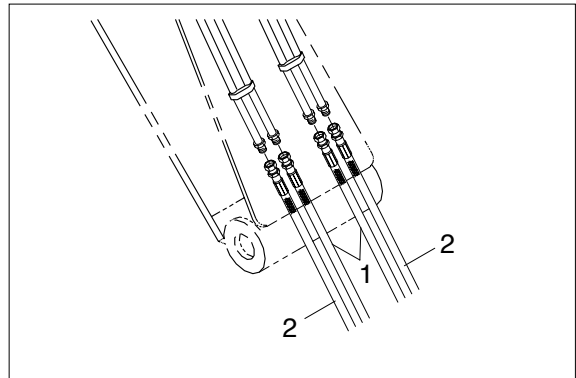

Sling boom assembly(3).

Remove bolt(4), plate(5) and pull out the pin(6) then remove boom assembly.

· Weight : 430kg(948lb)

When lifting the boom assembly always lift the center of gravity.

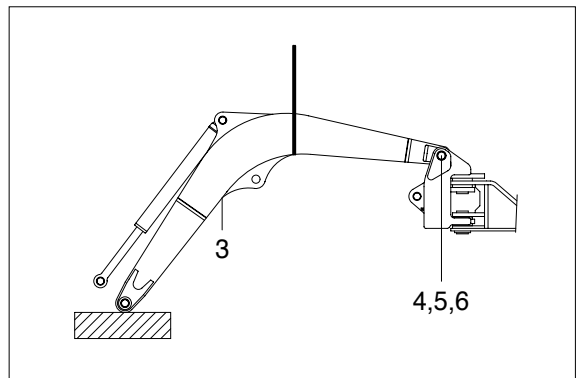

(2) Install

Carry out installation in the reverse order to removal.

▲ When lifting the arm assembly, always lift the center of gravity.

Bleed the air from the cylinder.

