

GROUP 2 MAJOR COMPONENT

1. MAIN PUMP

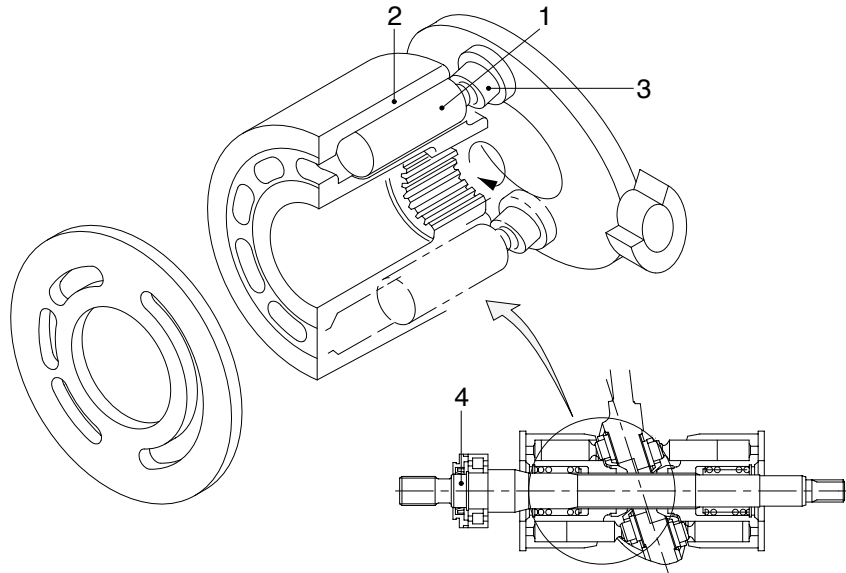
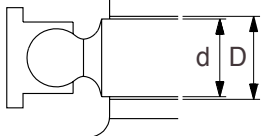
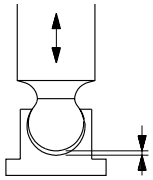
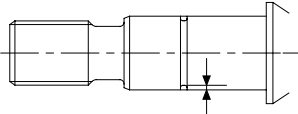

Part name & inspection item		Recommended replacement value	Counter measures
Clearance between piston(1) & cylinder bore(2) (D-d)		0.050	Replace piston or cylinder
Play between piston(1) & shoe caulking section(3) ()		0.2	Replace assembly of piston & shoe
Wear of shaft ()		0.025	Replace shaft

2. MAIN CONTROL VALVE

Part name	Inspection item	Criteria & measure
Casing	<ul style="list-style-type: none"> Existence of scratch, rusting or corrosion 	<ul style="list-style-type: none"> In case of damage in following section, replace part. <ul style="list-style-type: none"> Sliding sections of casing fore and spool, especially land sections applied with holded pressure. Seal pocket section where spool is inserted. Seal section of port where O-ring contacts. Seal section of each relief valve for main, travel, and port. Other damages that may damage normal functions.
Spool	<ul style="list-style-type: none"> Existence of scratch, gnawing, rusting or corrosion. O-ring seal sections at both ends. Insert spool in casing hole, rotate and reciprocate it. 	<ul style="list-style-type: none"> Replacement when its outside sliding section has scratch(Especially on seals-contacting section). Replacement when its sliding section has scratch. Correction or replacement when O-ring is damaged or when spool does not move smoothly.
Poppet	<ul style="list-style-type: none"> Damage of poppet or spring. Insert poppet into casing and function it. 	<ul style="list-style-type: none"> Correction or replacement when sealing is incomplete. Normal when it can function lightly without being caught.
Around spring	<ul style="list-style-type: none"> Rusting, corrosion, deformation or breaking of spring, spring seat, plug or cover. 	<ul style="list-style-type: none"> Replacement for significant damage.
Around seal for spool	<ul style="list-style-type: none"> External oil leakage Rusting, corrosion or deformation of seal plate 	<ul style="list-style-type: none"> Correction or replacement Correction or replacement
Main relief valve, port relief valve & negative control relief valve	<ul style="list-style-type: none"> External rusting or damage Contacting face of valve seat Contacting face of poppet Abnormal spring O-rings, back up rings and seals 	<ul style="list-style-type: none"> Replacement Replacement when damaged Replacement when damaged Replacement 100% replacement in general

3. SWING DEVICE

Part name	Inspection item	Criteria & measure
Balance plate	<ul style="list-style-type: none"> · Worn less than 0.03mm · Worn more than 0.03mm · Sliding surface has a seizure(Even though small). 	<ul style="list-style-type: none"> · Lapping · Replace · Replace
Shoe of piston assembly	<ul style="list-style-type: none"> · Sliding surface has a damage. · Sliding surface depression() dimension less than 0.45mm or has a large damage. 	<ul style="list-style-type: none"> · Lapping · Replace parts or motor
Piston of piston assembly	<ul style="list-style-type: none"> · Sliding surface has a seizure(Even though small). 	<ul style="list-style-type: none"> · Replace motor
Piston hole of cylinder assembly	<ul style="list-style-type: none"> · Sliding surface has a seizure. · Sliding surface has a damage. 	<ul style="list-style-type: none"> · Replace motor · Replace motor
Taper roller bearing Needle bearing Roller bearing	<ul style="list-style-type: none"> · In case 3000hour operation. · Rolling surface has a damage. 	<ul style="list-style-type: none"> · Replace · Replace

4. RCV LEVER

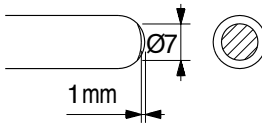
Maintenance check item	Criteria	Remark
Leakage	The valve is to be replaced when the leakage becomes more than 1000cc/m at neutral handle position, or more than 2000cc/m during operation.	Conditions : Primary pressure : 30kgf/cm ² Oil viscosity : 23cSt
Spool	This is to be replaced when the sliding surface has worn more than 10 μm, compared with the non-sliding surface.	The leakage at the left condition is estimated to be nearly equal to the above leakage.
Push rod	 <p>This is to be replaced when the top end has worn more than 1mm.</p>	
Play at operating section	The pin, shaft, and joint of the operating section are to be replaced when their plays become more than 2mm due to wears or so on.	When a play is due to looseness of a tightened section, adjust it.
Operation stability	When abnormal noises, hunting, primary pressure drop, etc. are generated during operation, and these cannot be remedied, referring to section 6 troubleshooting, replace the related parts.	

- Notes
1. It is desirable to replace seal materials, such as O-rings, every disassembling. However, they may be reused, after being confirmed to be free of damage.
 2. When loosening the hexagon socket head cap screw(125), replace the seal washers(121) without fail.

5. ACCELERATOR PEDAL

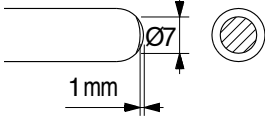
Maintenance check item	Criteria	Remark
Leakage	The valve is to be replaced when the leakage effect to the system. For example, the primary pressure drop.	Conditions : Primary pressure : 30kgf/cm ² Oil viscosity : 23cSt
Spool	This is to be replaced when the sliding surface has worn more than 10 μm, compared with the non-sliding surface.	The leakage at the left condition is estimated to be nearly equal to the above leakage.
Push rod	 <p>This is to be replaced when the top end has worn more than 1mm.</p>	
Play at operating section	The pin, shaft, and joint of the operating section are to be replaced when their plays become more than 2mm due to wears or so on.	When a play is due to looseness of a tightened section, adjust it.
Operation stability	When abnormal noises, hunting, primary pressure drop, etc. are generated during operation, and these cannot be remedied, referring to section 6 troubleshooting, replace the related parts.	

Notes 1. It is desirable to replace seal materials, such as O-rings, every disassembling. However, they may be reused, after being confirmed to be free of damage.

6. TURNING JOINT

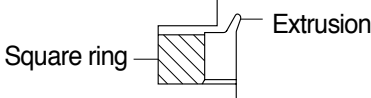
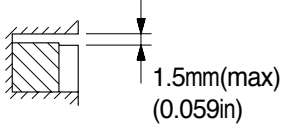
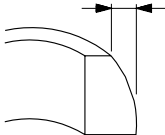
Part name		Maintenance standards	Remedy
Body, Stem	Sliding surface with sealing sections	Plating worn or peeled due to seizure or contamination	Replace
	Sliding surface between body and stem other than sealing section	· Worn abnormality or damaged more than 0.1mm (0.0039in) in depth due to seizure contamination	Replace
		· Damaged more than 0.1mm(0.0039in) in depth	Smooth with oilstone
	Sliding surface with thrust plate	· Worn more than 0.5mm(0.02in) or abnormality	Replace
		· Worn less than 0.5mm(0.02in)	Smooth
		· Damage due to seizure or contamination remediable within wear limit (0.5mm)(0.02in)	Smooth
Cover	Sliding surface with thrust plate	· Worn more than 0.5mm(0.02in) or abnormality	Replace
		· Worn less than 0.5mm (0.02in)	Smooth
		· Damage due to seizure or contamination remediable within wear limit (0.5mm)(0.02in)	
Seal set	-	<ul style="list-style-type: none"> Extruded excessively from seal groove square ring 	Replace
	-	<ul style="list-style-type: none"> Slipper ring 1.5mm(0.059in) narrower than seal groove, or narrower than back ring 	Replace
	-	<ul style="list-style-type: none"> Worn more than 0.5mm(0.02in) ~ 1.5mm(MAX) (0.059in) 	Replace

7. CYLINDER

Part name	Inspecting section	Inspection item	Remedy
Piston rod	· Neck of rod pin	· Presence of crack	· Replace
	· Weld on rod hub	· Presence of crack	· Replace
	· Stepped part to which piston is attached	· Presence of crack	· Replace
	· Threads	· Presence of crack	· Recondition or replace
	· Plated surface	· Plating is not worn off to base metal	· Replace or replate
		· Rust is not present on plating	· Replace or replate
· Scratches are not present		· Recondition, replate or replace	
· Rod	· Wear of O.D.	· Recondition, replate or replace	
Cylinder tube	· Bushing at mounting part	· Wear of I.D.	· Replace
	· Weld on bottom	· Presence of crack	· Replace
	· Weld on head	· Presence of crack	· Replace
	· Weld on hub	· Presence of crack	· Replace
	· Tube interior	· Presence of faults	· Replace if oil leak is seen
	· Bushing at mounting part	· Wear on inner surface	· Replace
Gland	· Bushing	· Flaw on inner surface	· Replace if flaw is deeper than coating