

GROUP 3 ELECTRICAL CIRCUIT

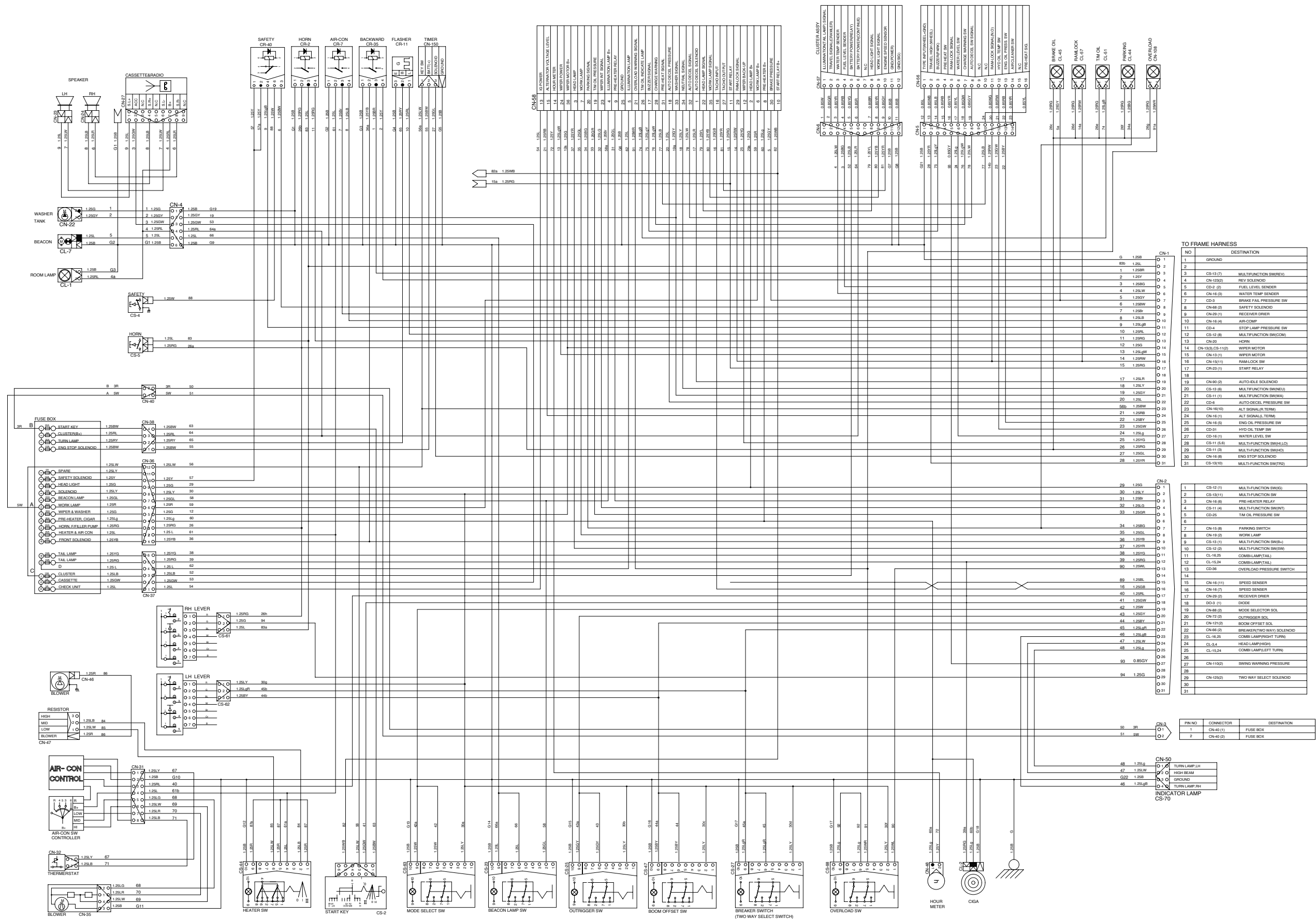

TO FRAME HARNESS

NO	DESTINATION
1	GROUND
2	
3	CS-13 (7) MULTIFUNCTION SW(REV)
4	CN-12(2) REV SOLENOID
5	CS-2 (2) FUEL LEVEL SENSOR
6	CN-14 (3) WATER TEMP SENSOR
7	CS-3 BRAKE FAIL PRESSURE SW
8	CN-8 (2) SAFETY SOLENOID
9	CN-29 (1) RECEIVER DRMR
10	CN-14 (4) AIR COMP
11	CS-4 STOP LAMP PRESSURE SW
12	CS-12 (8) MULTIFUNCTION SW(COM)
13	CN-25 HORN
14	CN-15(CS-110) WIPER MOTOR
15	CN-13 (1) WIPER MOTOR
16	CN-15(11) RAM-LOCK SW
17	CR-23 (1) START RELAY
18	
19	CN-80 (2) AUTO-HEEL SOLENOID
20	CS-13 (8) MULTIFUNCTION SW(W/L)
21	CS-11 (1) MULTIFUNCTION SW(W/L)
22	CS-4 AUTO-HEEL PRESSURE SW
23	CN-16(10) ALT SIGNAL SW
24	CN-18 (1) ALT SIGNAL TERM
25	CN-16 (5) ENG OIL PRESSURE SW
26	CS-31 HYD OIL TEMP SW
27	CS-16 (1) WATER LEVEL SW
28	CS-11 (5,6) MULTIFUNCTION SW(HELD)
29	CS-11 (3) MULTIFUNCTION SW(S)
30	CN-18 (8) ENG STOP SOLENOID
31	CS-12(10) MULTIFUNCTION SW(S)

1	CS-12 (1) MULTIFUNCTION SW(S)
2	CS-13(11) MULTIFUNCTION SW
3	CN-18 (6) PRE-HEATER RELAY
4	CS-11 (4) MULTIFUNCTION SW(S)
5	CS-25 TAM OIL PRESSURE SW
6	
7	CN-15 (8) PARKING SWITCH
8	CN-19 (2) WORK LAMP
9	CS-13 (1) MULTIFUNCTION SW(S)
10	CS-12 (2) MULTIFUNCTION SW(S)
11	CL-16,25 COMB(LAMP/TAL)
12	CL-15,24 COMB(LAMP/TAL)
13	CS-26 OVERLOAD PRESSURE SWITCH
14	
15	CN-16 (11) SPEED SENSOR
16	CN-16 (7) SPEED SENSOR
17	CN-29 (2) RECEIVER DRMR
18	CS-3 (1) COKE
19	CN-8 (2) MODE SELECTOR SW
20	CN-7 (2) OUTRIGGER SW
21	CN-12(10) BOOM OFFSET SW
22	CN-8 (3) BREAKER/TWO WAY SOLENOID
23	CL-16,25 COMB(LAMP/TAL)
24	CL-3,4 HEAD LAMP(HIGH)
25	CL-15,24 COMB(LAMP/LEFT TURN)
26	
27	CN-11(2) SWING WARNING PRESSURE
28	
29	CN-12(2) TWO WAY SELECT SOLENOID
30	
31	

PR NO	CONNECTOR	DESTINATION
1	CN-40 (1)	FUSE BOX
2	CN-40 (2)	FUSE BOX

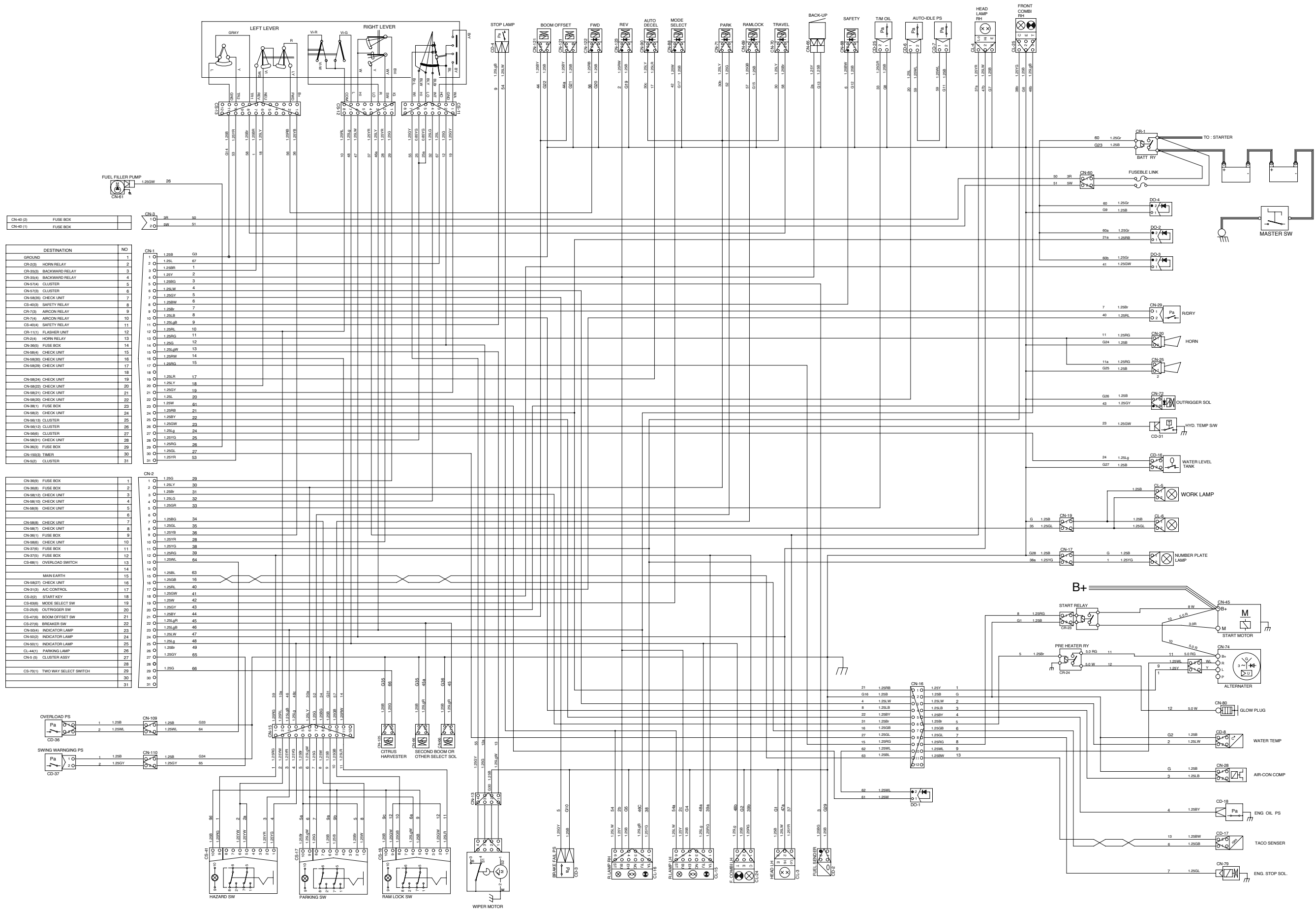

1. POWER CIRCUIT

The negative terminal of battery is grounded to the machine chassis through master switch.
When the start switch is in the OFF position, the current flows from the positive battery terminal as shown below.

1) OPERATING FLOW

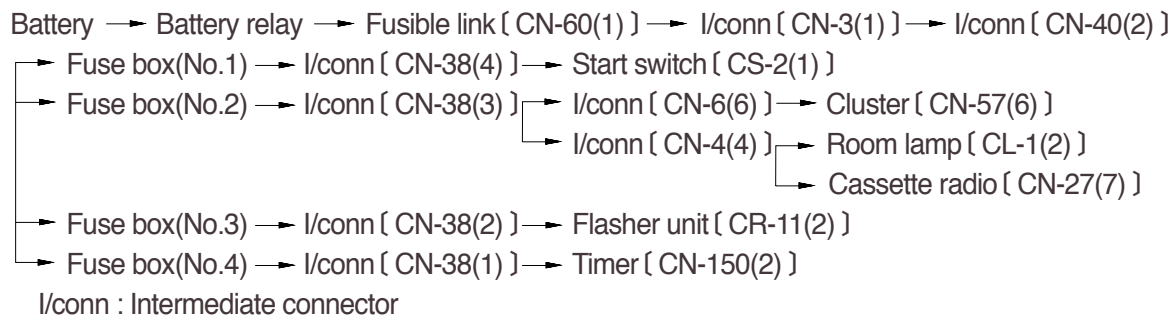

2) CHECK POINT

Engine	Start switch	Check point	Voltage
OFF	OFF	- GND(Battery 1EA)	10~12.5V
		- GND(Battery 2EA)	20~25V
		- GND(Battery 2EA)	20~25V
		- GND(Fusible link)	20~25V

GND : Ground

POWER CIRCUIT

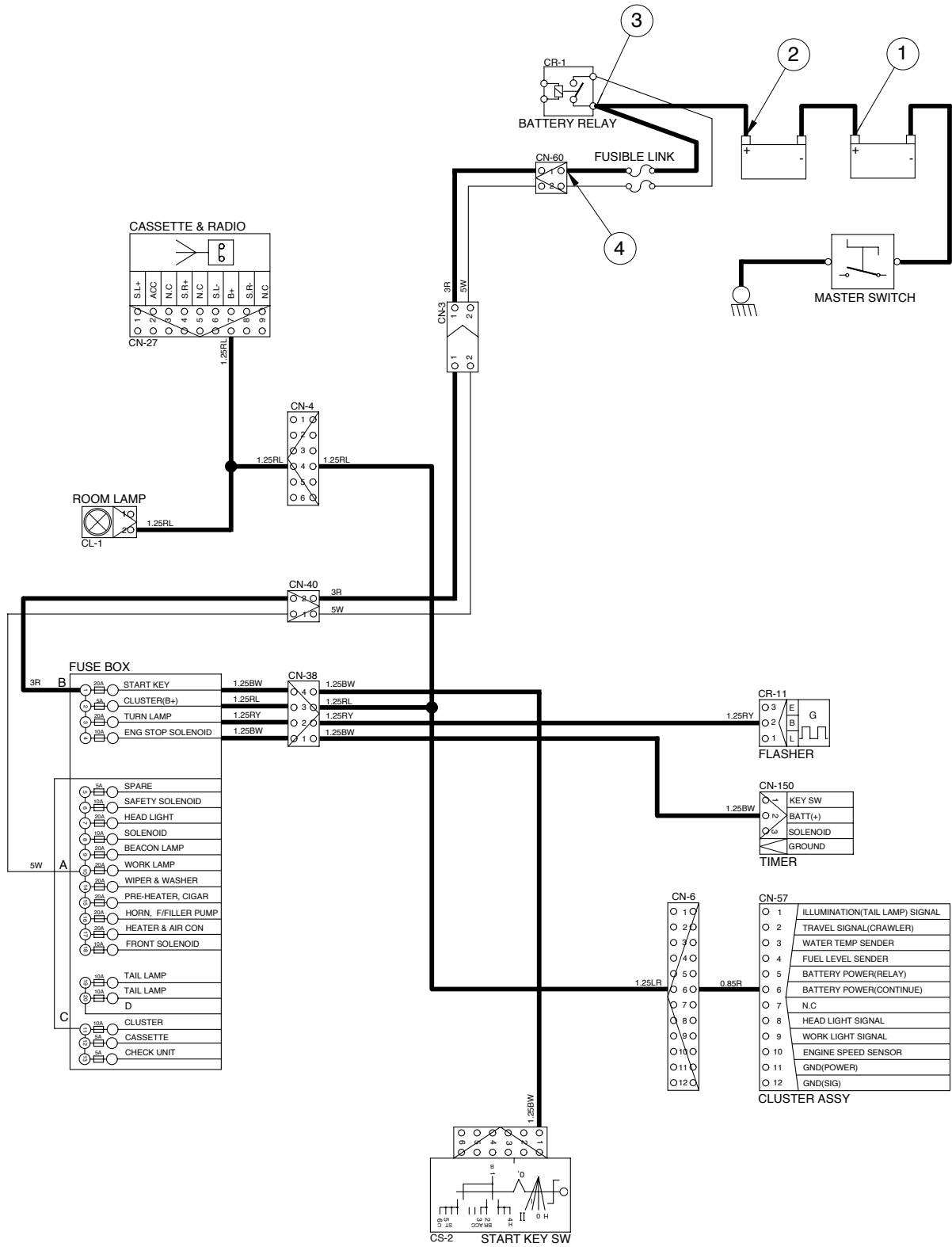

2. STARTING CIRCUIT

1) OPERATING FLOW

Battery(+) terminal → Battery relay(M8, B⁺ terminal) → Fusible link [CN-60(1)]
 → I/conn [CN-3(1)] → I/conn [CN-40(2)] → Fuse box(No.1) → I/conn [CN-38(4)]
 → Start switch [CS-2(1)]

(1) When start key switch is in ON position

→ Start switch ON [CS-2(2)] → I/conn [CN-2(18)] → Battery relay [M4 terminal]
 → Battery relay operating(All power is supplied with the electric component)
 → Start switch ON [CS-2(3)] → I/conn [CN-1(23)] → I/conn [CN-16(10)]
 → Alternater [CN-74(2)] (R terminal)
 → Timer [CN-150(1)]

(2) When start key switch is in START position

Start switch START [CS-2(5)] → Check unit (Start relay B⁺) → I/conn [CN-1(17)]
 → I/conn [CN-16(9)] → Start relay [CR-23(1)]

2) CHECK POINT

Engine	Start switch	Check point	Voltage
OPERATING	START	- GND(Battery) - GND(Start key) - GND(Battery relay M4) - GND(Start B+) - GND(Start M) - GND(Start relay) - GND(Battery relay M8) - GND(Check unit 10) - GND(Check unit 11)	20~25V

GND : Ground

STARTING CIRCUIT

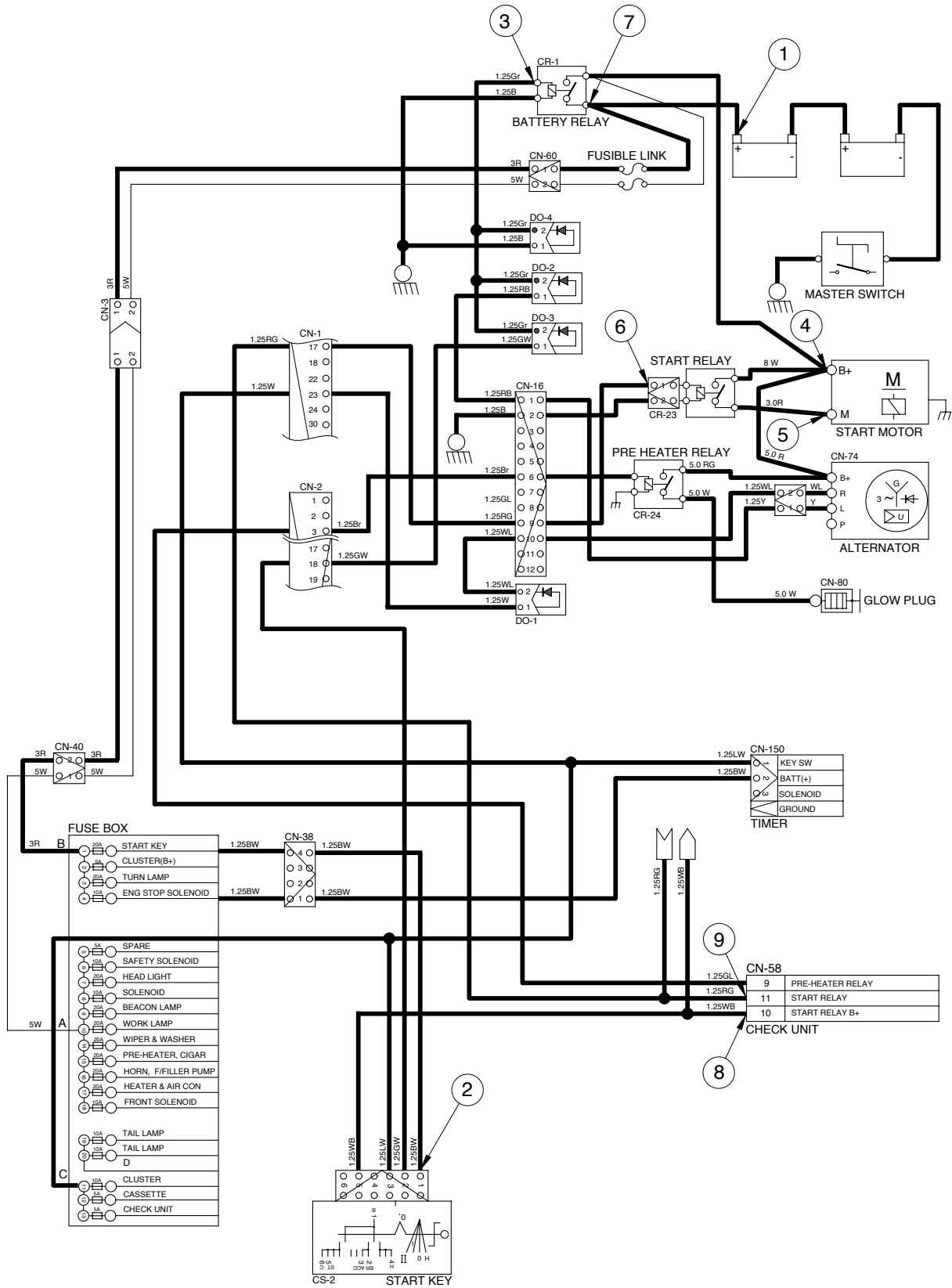

3. CHARGING CIRCUIT

When the starter is activated and the engine is started, the operator releases the key switch to the ON position.

Charging current generated by operating alternator flows into the battery through the Battery relay (CR-1).

The current also flows from alternator to each electrical component and controller through the fuse box.

1) OPERATING FLOW

(1) Warning flow

Alternator "L" terminal → I/conn [CN-16(1)] → I/conn [CN-1(24)]

→ Check unit alternator voltage level [CN-58(15)] → I/conn [CN-5(7)]

→ Cluster charging warning switch [CN-56(7)]

(2) Charging flow

Alternator B⁺ terminal → Battery relay(M8) → Battery(+) terminal

2) CHECK POINT

Engine	Start switch	Check point	Voltage
RUN	ON	- GND(Battery voltage) - GND(Battery relay) - GND(Alternator B terminal) - GND(Alternator L terminal) - GND(Check unit)	20~30V

GND : Ground

CHARGING CIRCUIT

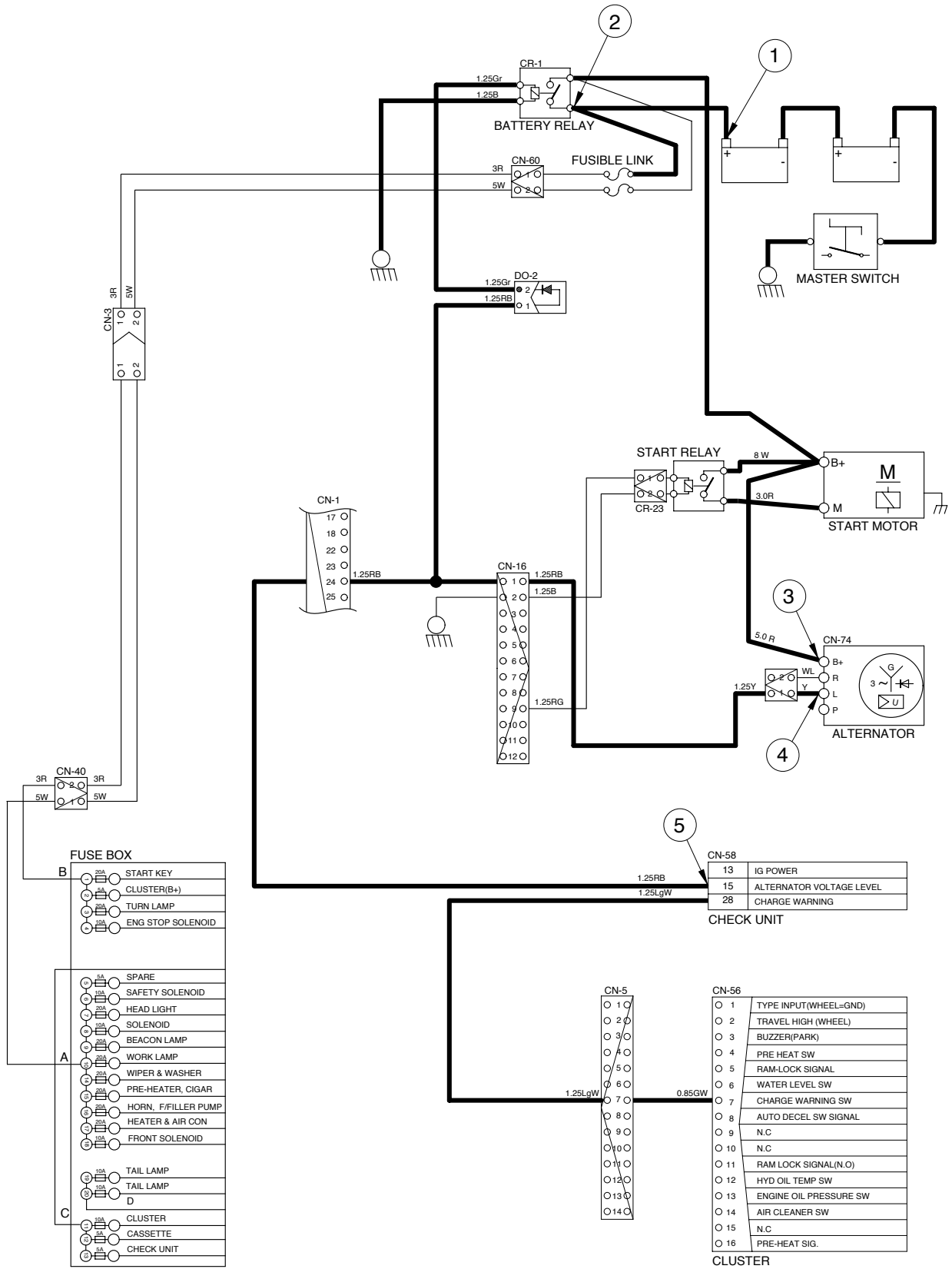

4. HEAD LIGHT AND CLEARANCE LAMP CIRCUIT

1) OPERATING FLOW

Fuse box(No.7) → I/conn [CN-36(9)] → I/conn [CN-2(1)] → RH multifunction switch(IG)
 → Passing function operating by RH multifunction up and down
 → I/conn [CN-36(9)] → Check unit head lamp B⁺ [CN-58(2)]

(1) Head light switch ON : 1st step

→ Cluster illumination lamp ON [CN-58(5)]
 → Fuse box (No.19) → I/conn [CN-37(6)] → I/conn [CN-2(11)] → RH clearance lamp ON
 → [Rear : CL-16(1), Front : CL-25(1)]
 → Fuse box (No.20) → I/conn [CN-37(5)] → I/conn [CN-2(12)] → LH clearance lamp ON
 → [Rear : CL-15(1), Front : CL-24(1)]
 → Number plate lamp ON [CN-17(2)]

(2) Head light switch ON : 2nd step

Head light switch ON [CS-12(2)] → or

RH multifunction switch : Lo

I/conn [CS-12(4)] → Head light low beam ON [CL-3(1), CL-4(1)]

RH multifunction switch : Hi

I/conn [CS-12(6)] → Head light high beam ON [CL-3(2), CL-4(2)]

2) CHECK POINT

Engine	Start switch	Check point	Voltage
STOP	ON	- GND(Fuse box) - GND(Switch power input) - GND(Switch power output) - GND(Head lamp) - GND(Clearance lamp) - GND(Numberplate lamp)	20~25V

GND : Ground

5. WORK LAMP CIRCUIT

1) OPERATING FLOW

Fuse box(No.10) → I/conn [CN-36(6)] → Check unit work lamp B+ [CN-58(6)]

When work light switch ON

Work light switch ON [CN-57(9)] → I/conn [CN-6(9)] → Check unit [CN-58(35) (7)]
→ I/conn [CN-2(8)] → I/conn [CN-19(2)] → Work light ON [CL-5(2), CL-6(2)]

2) CHECK POINT

Engine	Start switch	Check point	Voltage
STOP	ON	- GND(Fuse box) - GND(Switch power output) - GND(Switch power input) - GND(Cluster work lamp) - GND(Work lamp)	20~25V

GND : Ground

WORK LAMP CIRCUIT

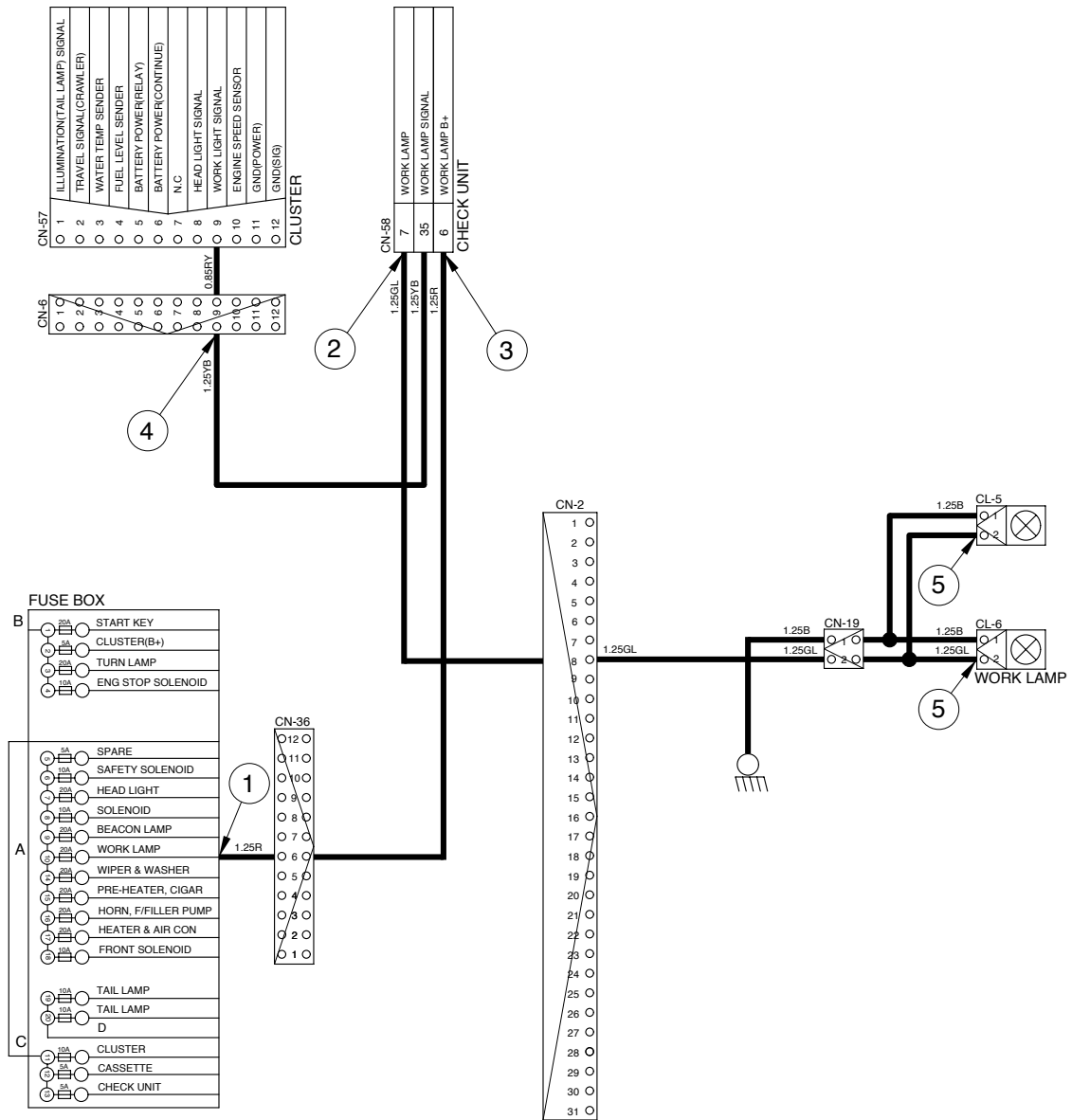

6. BEACON LAMP CIRCUIT

1) OPERATING FLOW

Fuse box(No.9) → I/conn { CN-36(7) } → Beacon lamp switch { CS-23(2) }

When Lamp switch ON

Beacon lamp switch ON { CS-23(6) } → Switch indicator lamp ON { CS-23(9) }
Beacon lamp switch ON { CS-23(6) } → I/conn { CN-14(5) } → Beacon lamp ON { CL-7 }

2) CHECK POINT

Engine	Start switch	Check point	Voltage
STOP	ON	- GND(Fuse box) - GND(Switch power input) - GND(Switch power output) - GND(Beacon lamp)	20~25V

GND : Ground

BEACON LAMP CIRCUIT

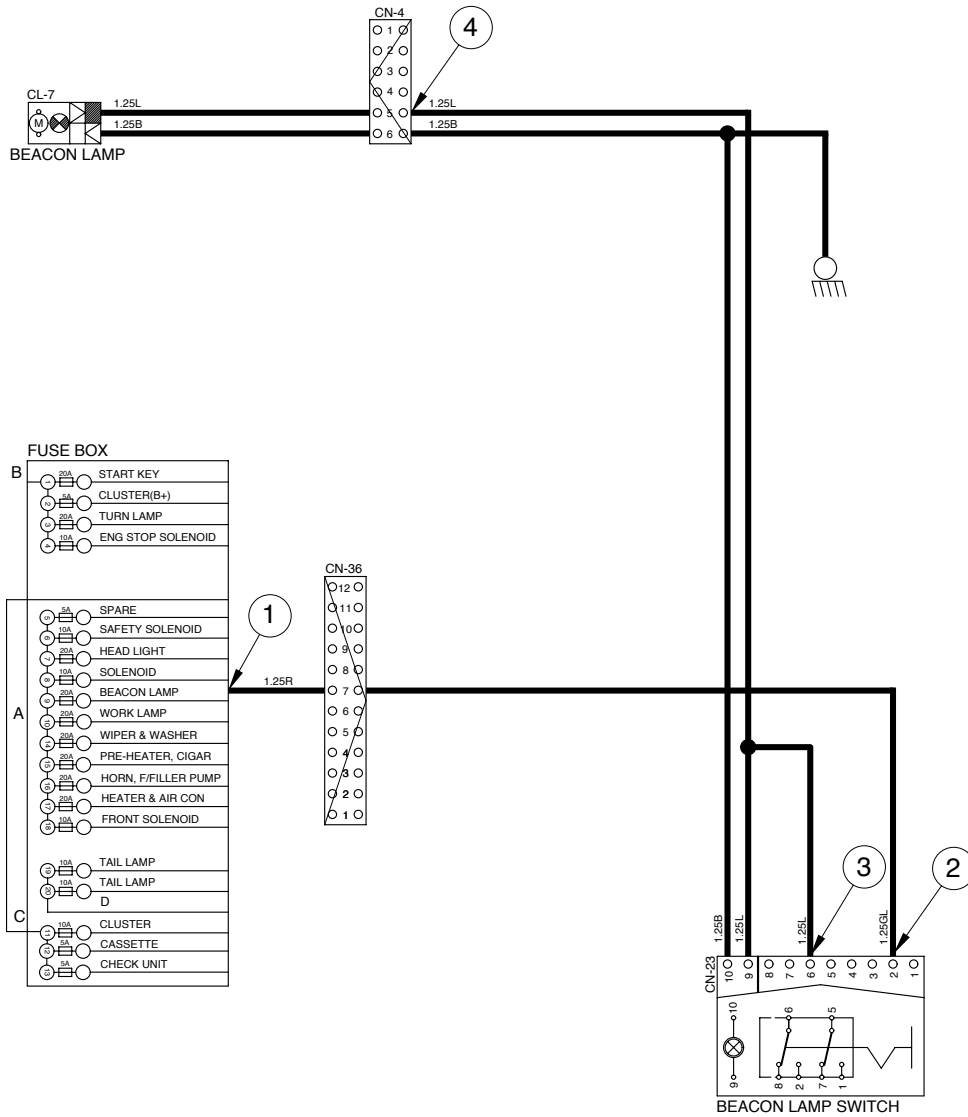

7. WIPER AND WASHER CIRCUIT

1) OPERATING FLOW

Fuse box (No.14) → I/conn [CN-36(5)]

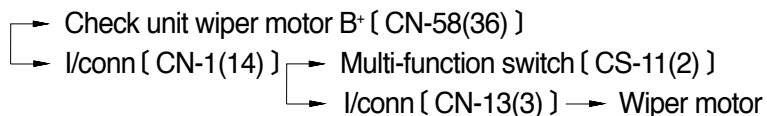

(1) Washer switch ON

Washer switch ON [CS-11(2) (1)] → I/conn [CN-1(21)]

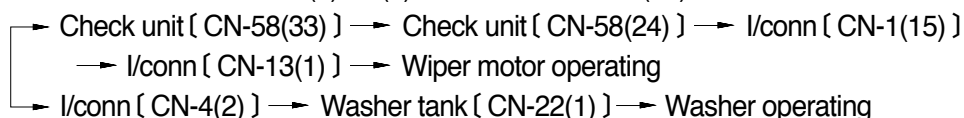

(2) Wiper switch ON : INT Position

Wiper switch ON [CS-11(2) (4)] → I/conn [CN-2(4)] → Check unit [CN-58(23)]

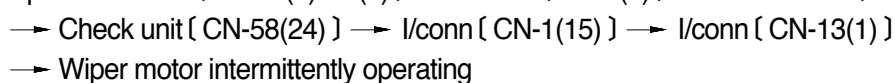

(3) Wiper switch ON : Low and Hi Position

Wiper switch ON [CS-11(2) (5) or (6)] → I/conn [CN-1(28)] → Check unit [CN-58(12)]

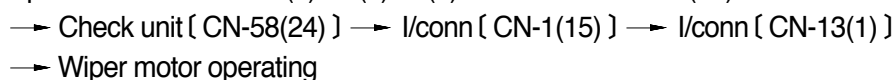

(4) Auto-parking(When switch OFF)

Wiper motor [CS-21(1)] → OFF → Fuse box (No.14) → I/conn [CN-36(5)]

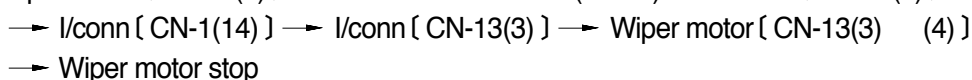

2) CHECK POINT

Engine	Start switch	Check point	Voltage
STOP	ON	- GND(Fuse box) - GND(Washer power output) - GND(Switch power input) - GND(Switch power input) - GND(Wiper power input) - GND(Wiper motor)	20~25V

GND : Ground

WIPER AND WASHER CIRCUIT

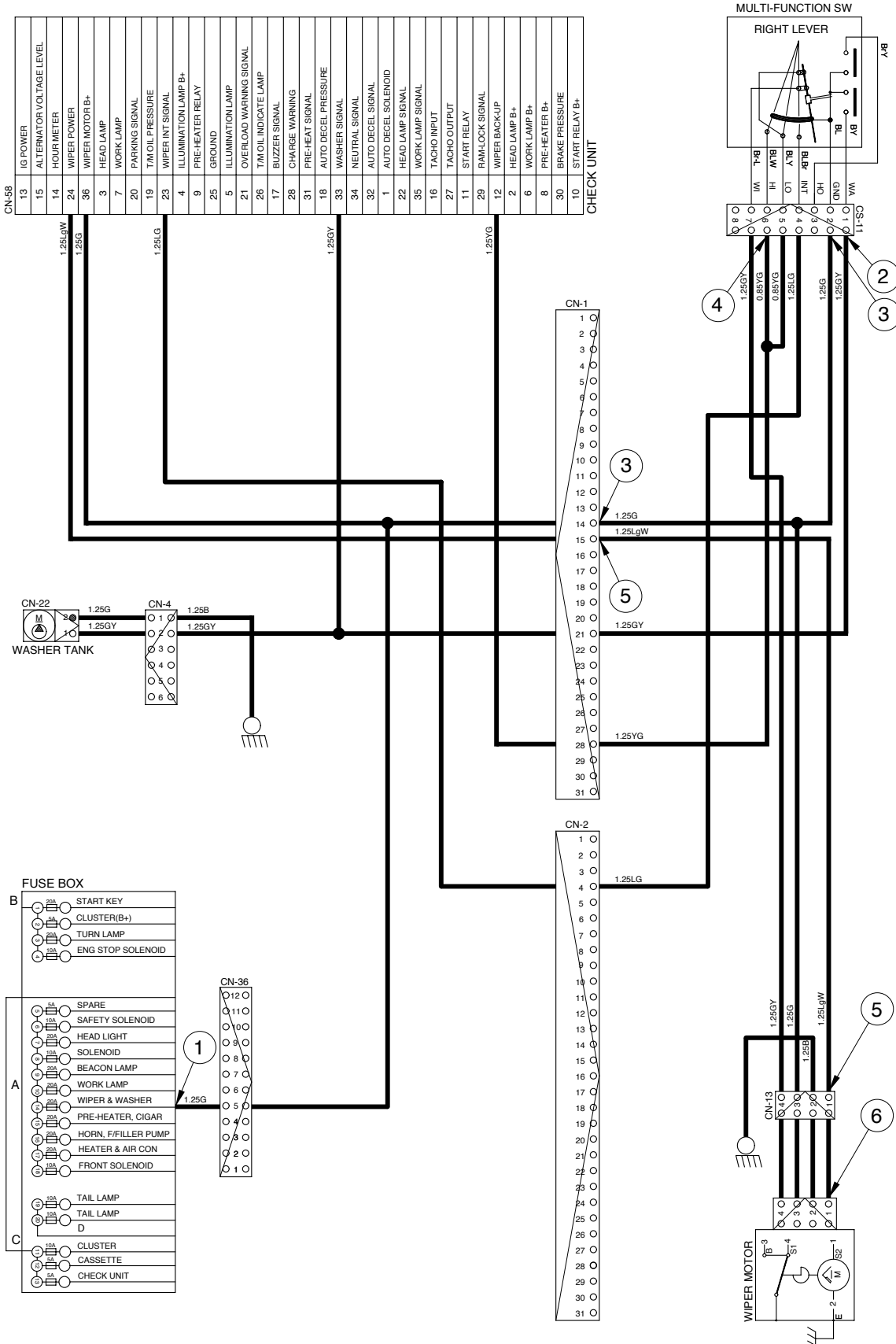

CN-58	13	IG POWER
	15	ALTERNATOR VOLTAGE LEVEL
	14	HOURLY METER
	24	WIPER POWER
	36	WIPER MOTOR B+
	7	WORK LAMP
	20	PARKING SIGNAL
	19	T/M OIL PRESSURE
	23	WIPER INT SIGNAL
	4	ILLUMINATION LAMP B+
	9	PRE-HEATER RELAY
	25	GROUND
	5	ILLUMINATION LAMP
	21	OVERLOAD WARNING SIGNAL
	26	T/M OIL INDICATE LAMP
	17	Buzzer SIGNAL
	28	CHARGE WARNING
	31	PRE-HEAT SIGNAL
	18	AUTO DECEL PRESSURE
	33	WASHER SIGNAL
	34	NEUTRAL SIGNAL
	1	AUTO DECEL SOLENOID
	22	HEAD LAMP SIGNAL
	35	WORK LAMP SIGNAL
	16	TACHO INPUT
	27	TACHO OUTPUT
	11	START RELAY
	29	RAM LOCK SIGNAL
	12	WIPER BACK-UP
	2	HEAD LAMP B+
	6	WORK LAMP B+
	8	PRE-HEATER B+
	30	BRAKE PRESSURE
	10	START RELAY B+
		CHECK UNIT

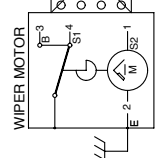
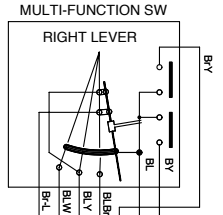
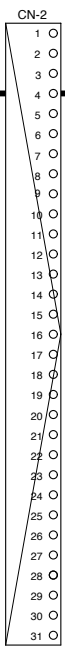
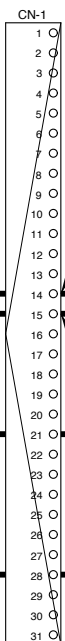
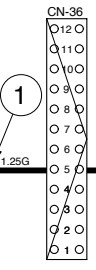
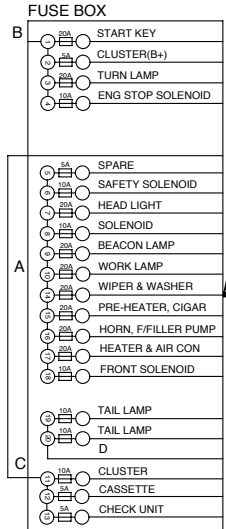
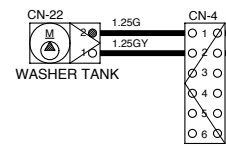

8. ANTI-RESTART CIRCUIT

- 1) After 5 seconds from the engine starts to run, check unit turns off the start safety relay to protect the starter from inadvertent restarting.
- 2) When a replacement or taking-off of the check unit is needed, connect CN-7 and CN-8 to ensure the engine start without the check unit.

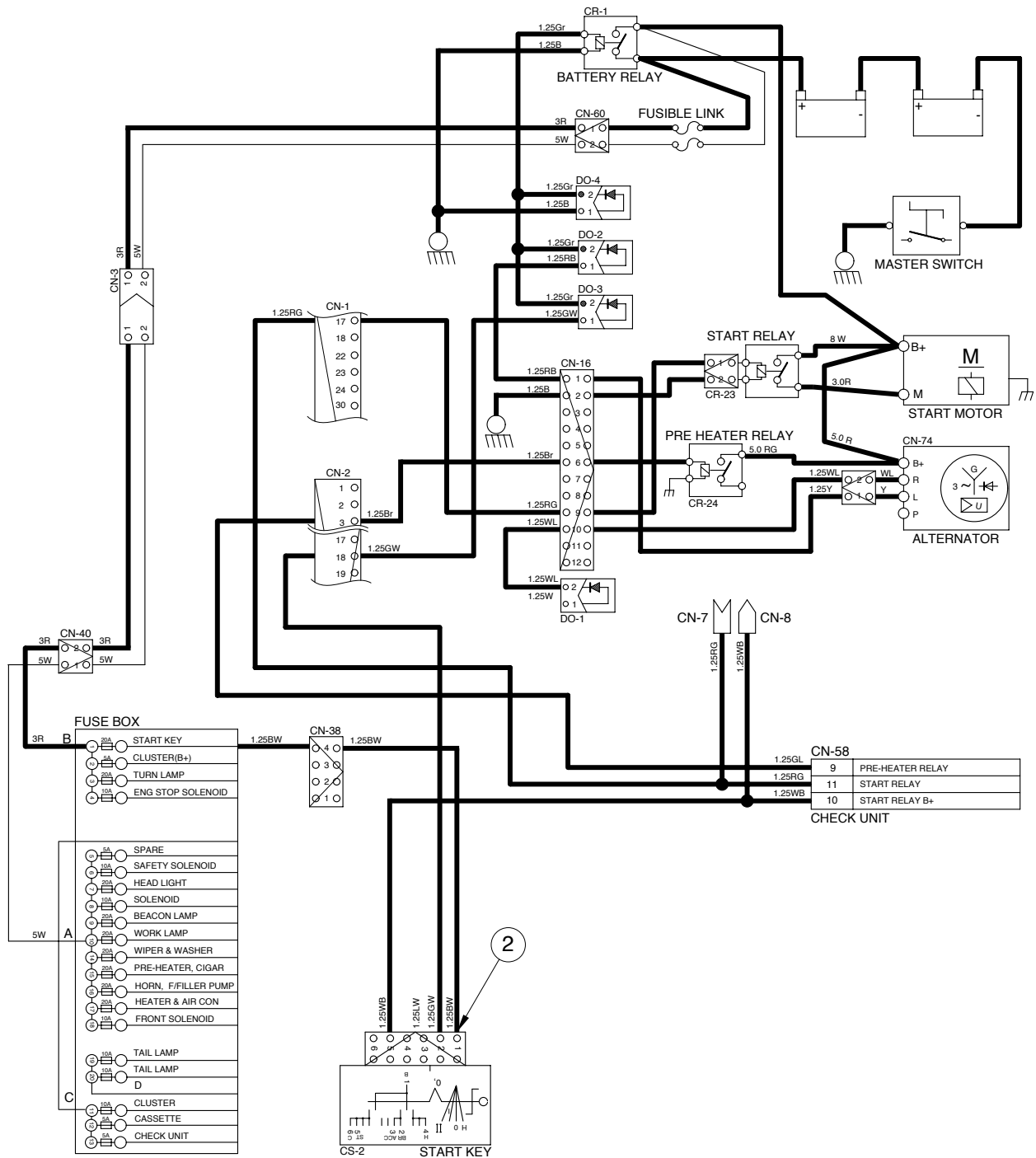

ELECTRIC CIRCUIT FOR HYDRAULIC

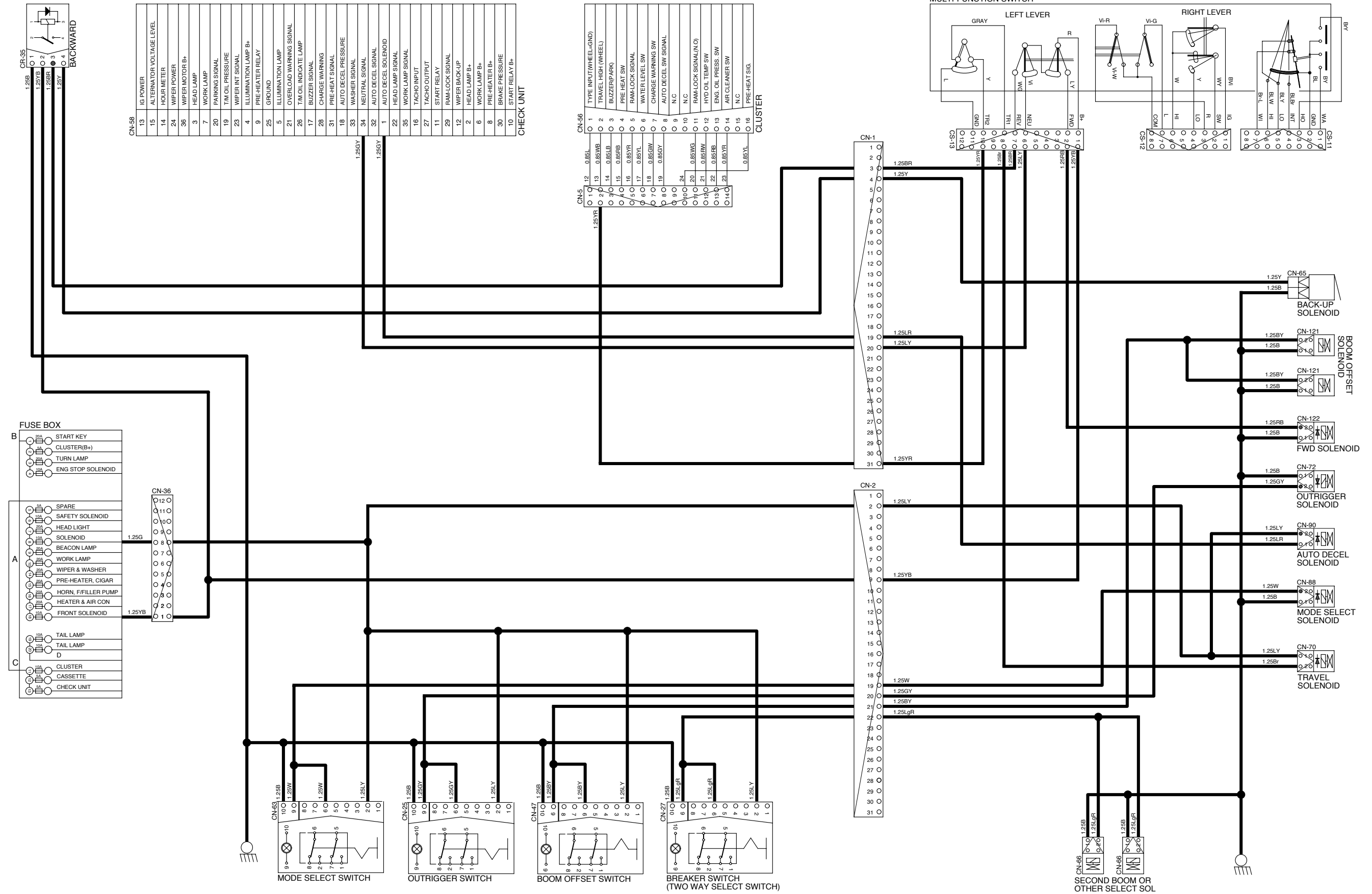

INDICATOR CIRCUIT

