

GROUP 5 COMBINED OPERATION

1. OUTLINE

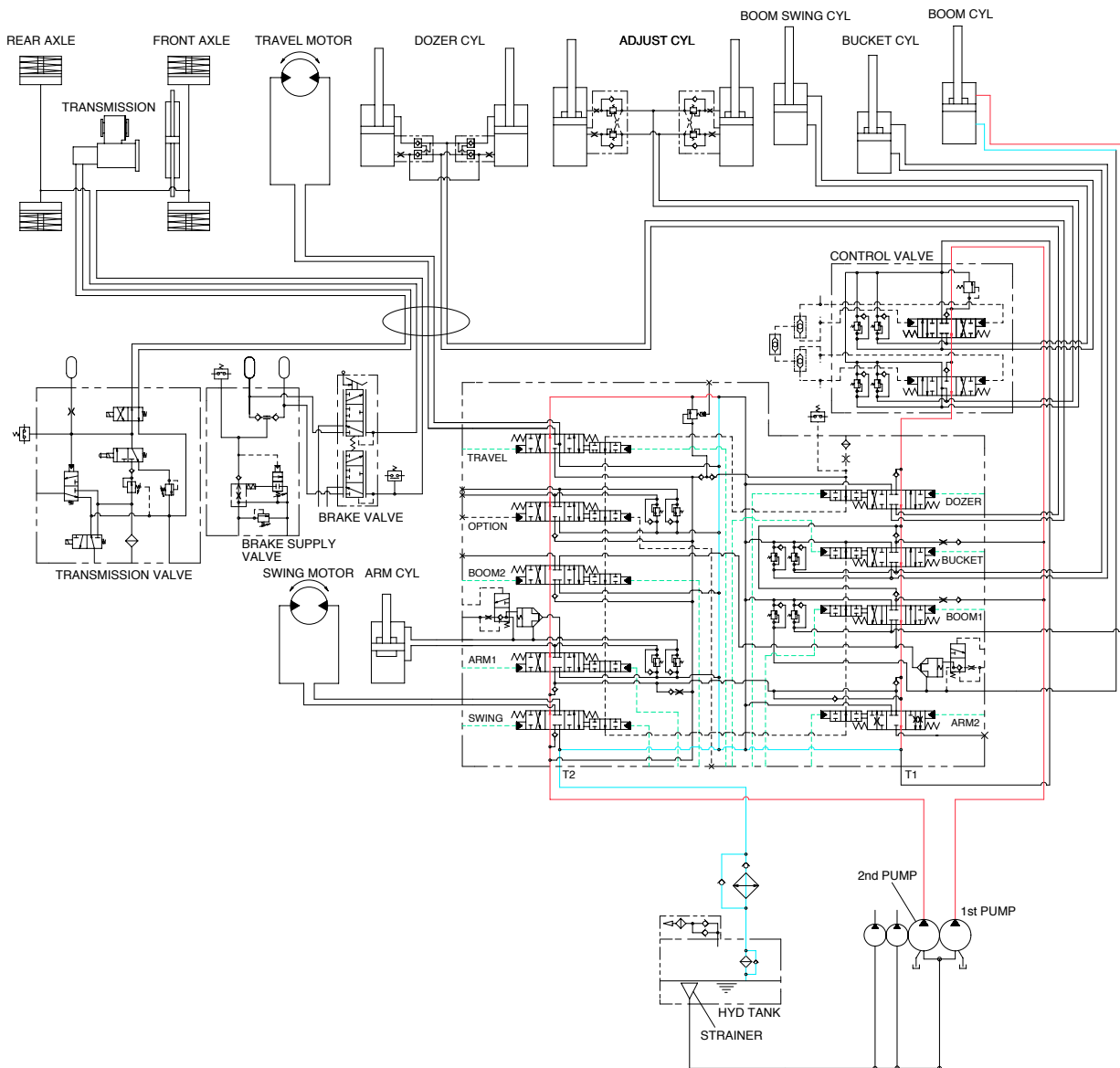

The oil from the 1st and 2nd pump flows through the neutral oil passage, bypass oil passage and confluence oil passage in the main control valve. Then the oil goes to each actuator and operates them. Check valves and orifices are located on these oil passage in the main control valve. These control the oil from the main pumps so as to correspond to the operation of each actuator and smooth the combined operation.

2. COMBINED SWING AND BOOM OPERATION

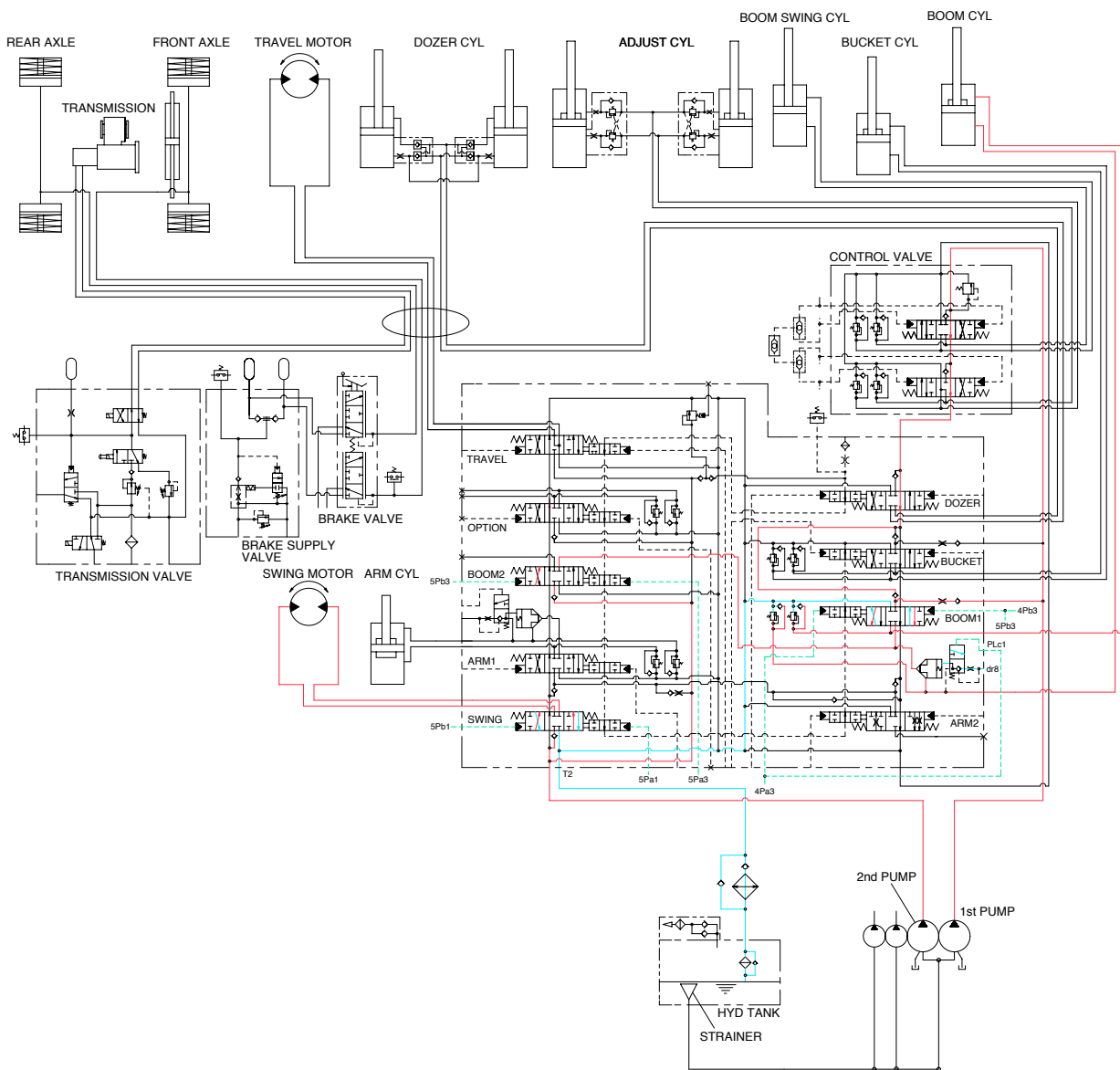

When the swing and boom functions are operated, simultaneously the swing spool and boom spools in the main control valve are moved to the functional position by the pilot oil pressure from the remote control valve.

The oil from the 1st pump flows into the boom cylinders through boom 1 spool in the right control valve.

The oil from the 2nd pump flows into the swing motor through swing spool.

At the same time, the pressure in the boom circuits can be high while the swing pressure is low, therefore the oil from the 2nd pump flows into the boom cylinders through boom 2 spool via confluence passage in case of boom raise operation. The superstructure swings and the boom is operated.

3. COMBINED SWING AND ARM OPERATION

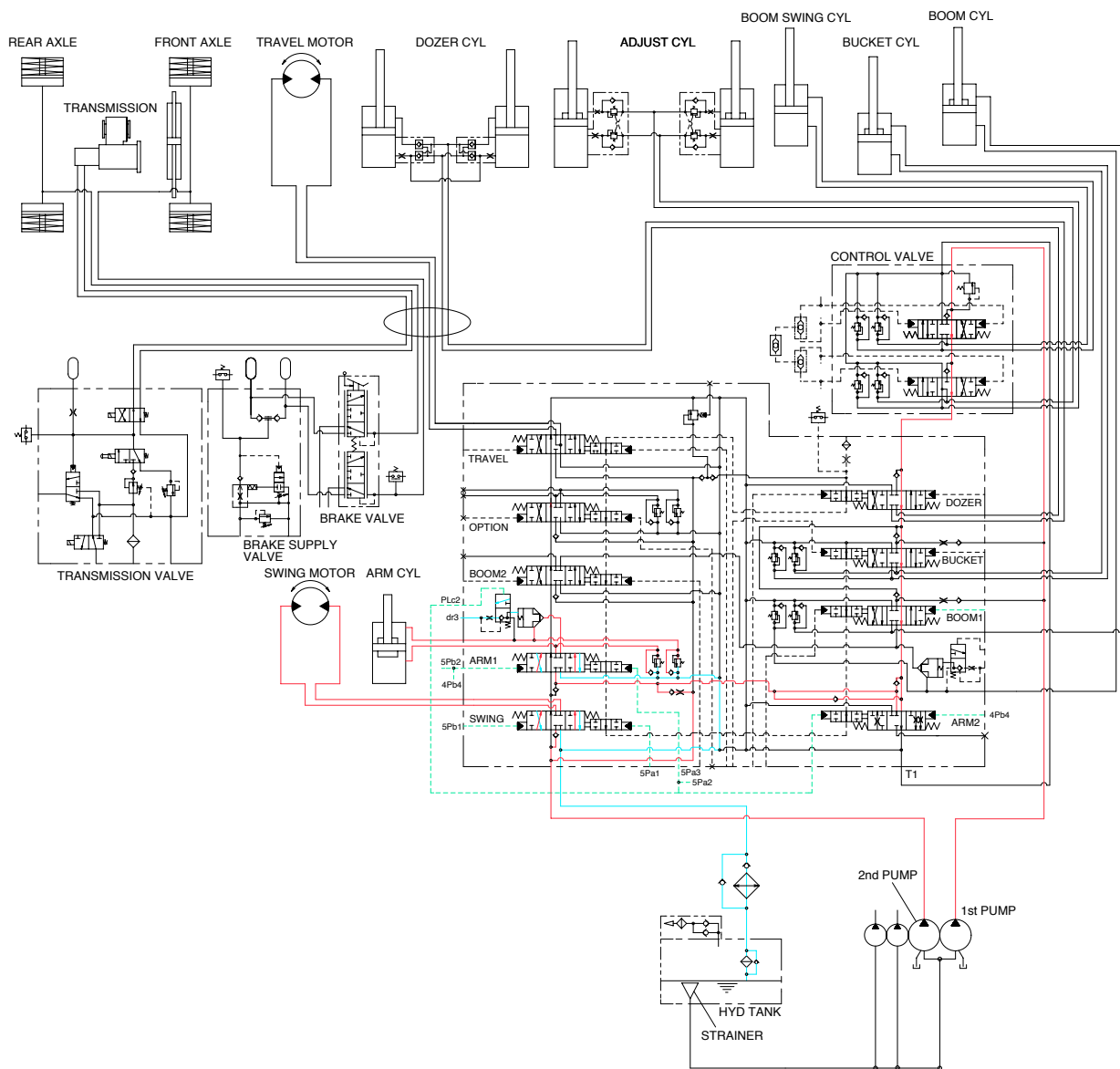

When the swing and arm functions are operated, simultaneously the swing spool and arm spools in the main control valve are moved to the functional position by the pilot oil pressure from the remote control valve. The oil from the 2nd pump flows into the swing motor through swing spool and arm cylinder through arm 1 spool.

At the same time, the pressure in the arm circuits can be high while the swing pressure is low, therefore the oil from the 1st pump flows into the arm cylinder through arm 2 spool via confluence passage. The superstructure swings and the arm is operated.

4. COMBINED SWING AND BUCKET OPERATION

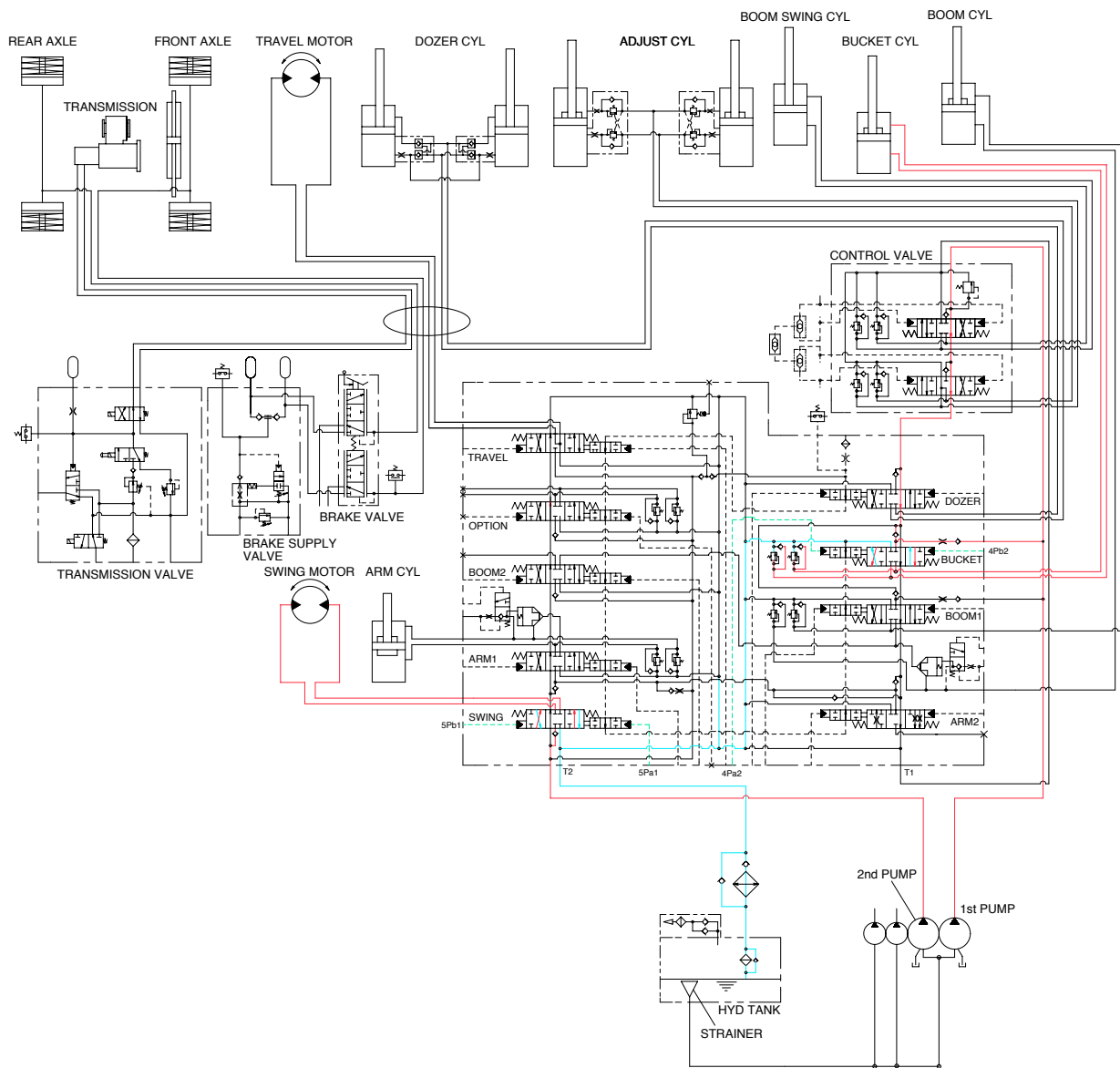

When the swing and bucket functions are operated, simultaneously the swing spool and bucket spool in the main control valve are moved to the functional position by the pilot oil pressure from the remote control valve.

The oil from the 1st pump flows into the bucket cylinder through bucket spool in the right control valve.

The oil from the 2nd pump flows into the swing motor through swing spool in the left control valve. The superstructure swings and the bucket is operated.

5. COMBINED SWING, BOOM, ARM AND BUCKET OPERATION

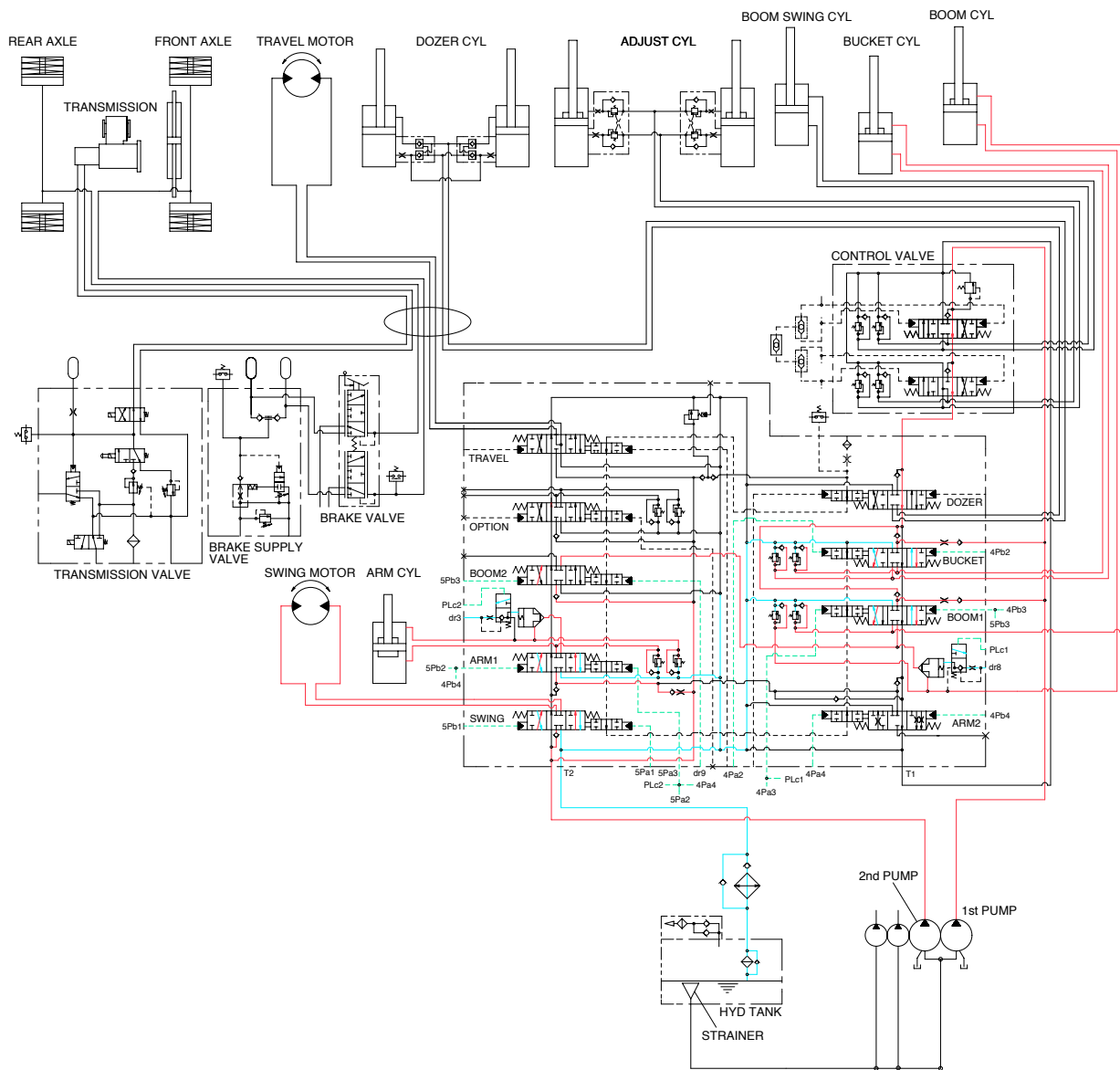

When the swing, boom, arm and bucket functions are operated, simultaneously each spool in the main control valve is moved to the functional position by the pilot oil pressure from the remote control valve. The oil from the 1st pump flows into the boom cylinder, bucket cylinder and arm cylinder through the boom 1 spool, bucket spool, arm 2 spool and the parallel and confluence oil passage in the right control valve. The oil from the 2nd pump flows into the swing motor, boom cylinder and arm cylinder through the swing spool, boom 2 spool, arm 1 spool, and the parallel and confluence oil passage in the left control valve. The superstructure swings and the boom, arm and bucket are operated.