

GROUP 2 MAIN CIRCUIT

The main hydraulic circuit consists of suction circuit, delivery circuit, return circuit and drain circuit.

The hydraulic system consists of one main pump, one control valve, one swing motor, six cylinders, one travel motor, one transmission, one front axle and one rear axle.

The variable displacement open loop bent axis double pump is used as the main pump and is driven by the engine at ratio 1.0 of engine speed.

1. SUCTION AND DELIVERY CIRCUIT

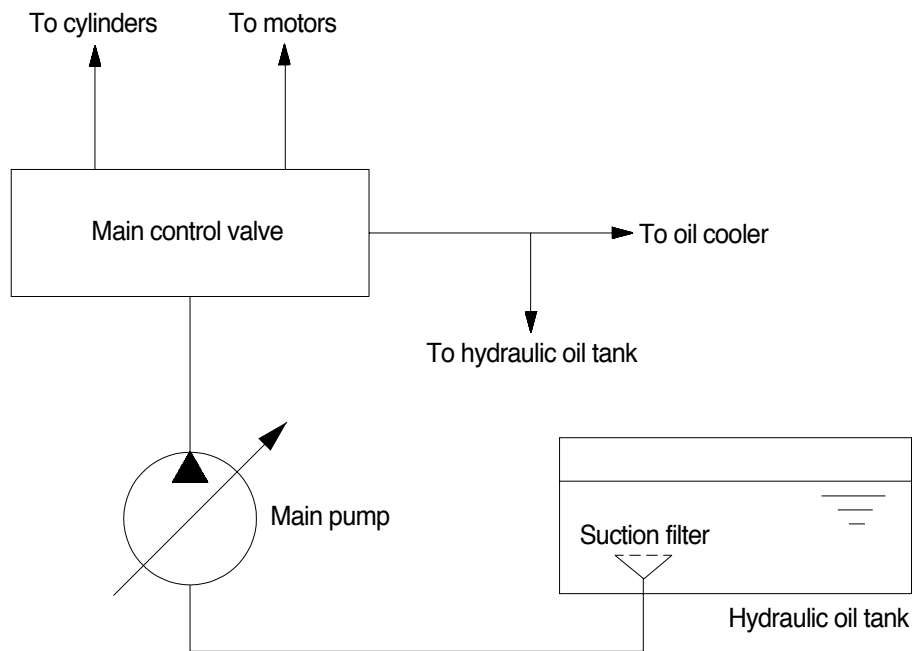

The pumps receive oil from the hydraulic tank through a suction filter. The discharged oil from the pump flows into the control valve and goes out of the tank ports.

The oil discharged from the main pump flows to the actuators through the control valve.

The control valve controls the hydraulic functions.

The oil returned from the actuators flows to the hydraulic tank through the control valve and the oil cooler.

2. RETURN CIRCUIT

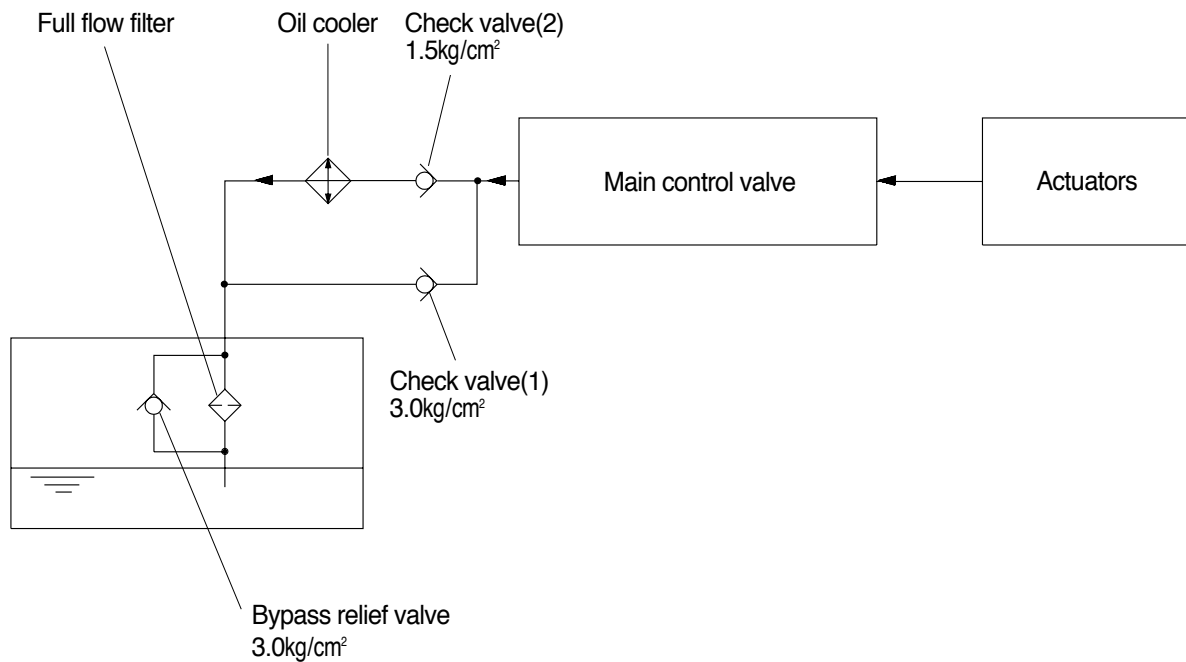

All oil returned from each actuator returns to the hydraulic tank through the control valve.

The bypass check valves are provided in the return circuit.

The setting pressure of bypass check valves are 1.5kg/cm²(21psi) and 3.0kg/cm²(43psi). Usually, oil returns to the hydraulic tank from the left side of control valve through oil cooler.

When oil temperature is low, viscosity becomes higher and flow resistance increases when passing through the oil cooler. The oil pressure exceeds 3.0kg/cm²(43psi), the oil returns directly to the hydraulic tank, resulting in the oil temperature being raised quickly at an appropriate level.

When the oil cooler is clogged, the oil returns directly to the hydraulic tank through bypass check valve(1).

The return filter and bypass relief valve are provided in the hydraulic tank.

The oil from right and left side of control valve is combined and filtered by the return filter. A bypass relief valve is provided in the full-flow filter.

When the filter element is clogged, the bypass relief valve opens at 3.0kg/cm²(43psi) differential pressure.

3. DRAIN CIRCUIT

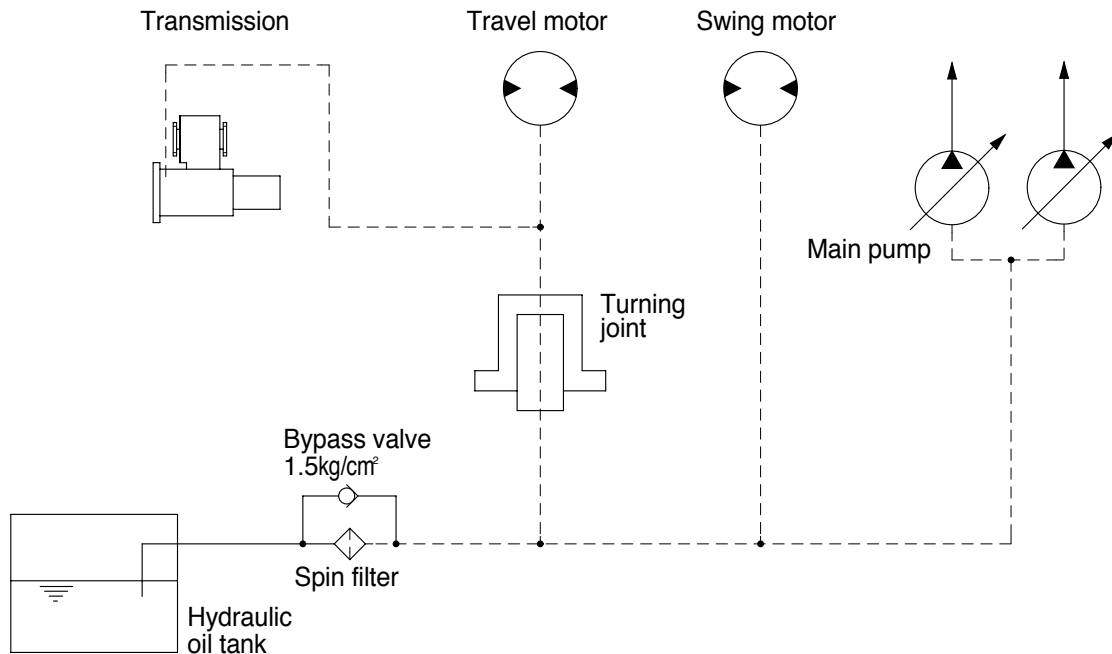

Besides internal leaks from the motor, main pump, transmission, front and rear axle, the oil for lubrication circulates. These oil have to be fed to the hydraulic tank passing through spin filter. When the drain oil pressure exceeds 1.5kg/cm^2 (21psi), the oil returns to the hydraulic tank directly.

1) TRAVEL MOTOR DRAIN CIRCUIT

Oil leaking from the travel motor comes out of the drain ports provided in the respective motor casing. This oil passes through the turning joint and returns to the hydraulic tank after being filtered by spin filter.

2) SWING MOTOR DRAIN CIRCUIT

Oil leaking from the swing motor comes out and returns to the hydraulic tank passing through a spin filter.

3) MAIN PUMP DRAIN CIRCUIT

Oil leaking from main pump comes out and returns to the hydraulic tank passing through drain filter.

4) TRANSMISSION DRAIN CIRCUIT

Oil leaking from transmission comes out and returns to the hydraulic tank passing through spin filter.