

**SECTION 3 HYDRAULIC SYSTEM**

**GROUP 1 HYDRAULIC CIRCUIT**

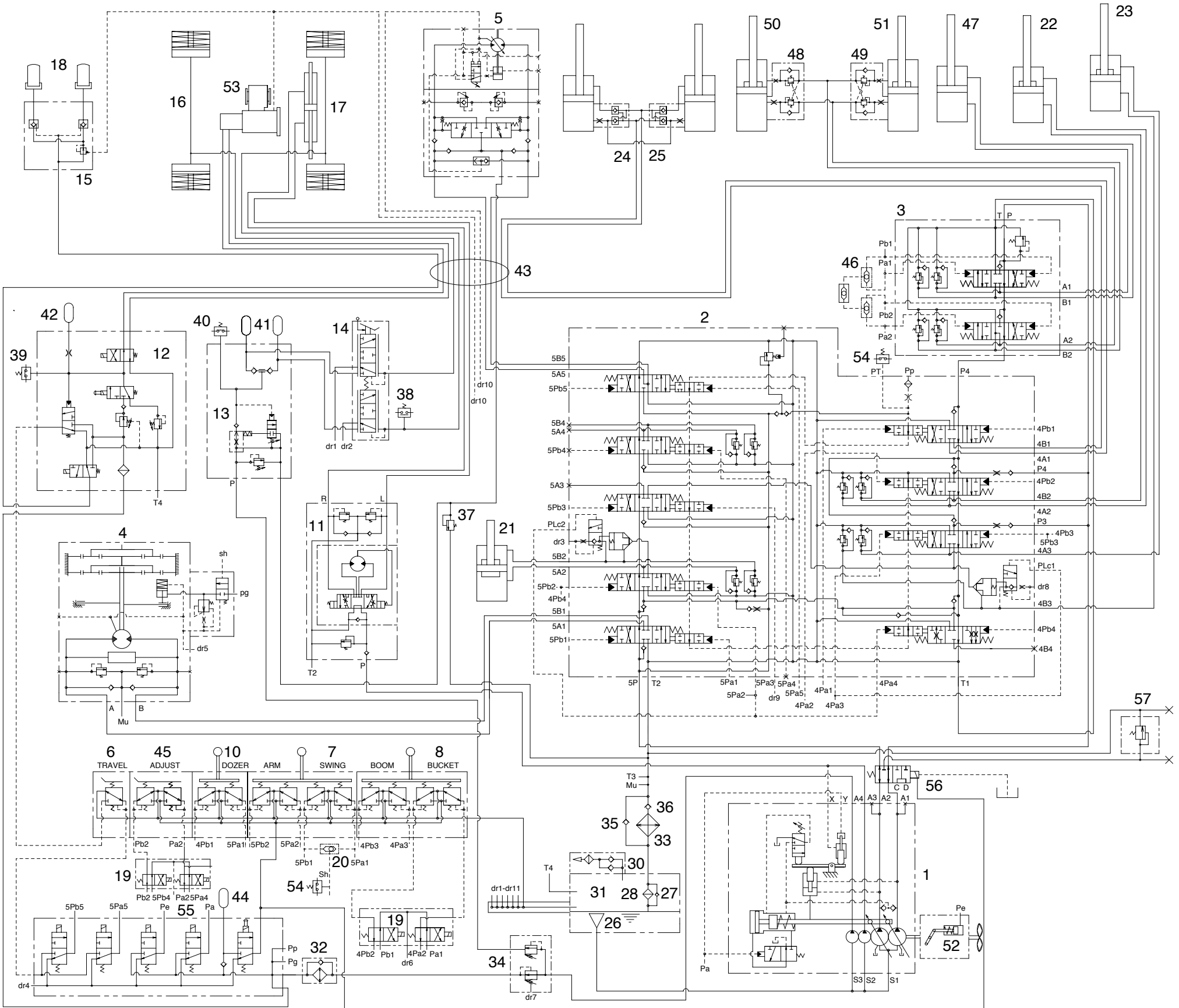

- |    |                            |    |                     |
|----|----------------------------|----|---------------------|
| 1  | Main pump                  | 30 | Air breather        |
| 2  | Main control valve         | 31 | Hydraulic tank      |
| 3  | Control valve              | 32 | Line filter         |
| 4  | Swing motor                | 33 | Oil cooler          |
| 5  | Travel motor               | 34 | Relief valve        |
| 6  | RCV pedal                  | 35 | Check valve         |
| 7  | RCV lever(LH)              | 36 | Check valve         |
| 8  | RCV lever(RH)              | 37 | Relief valve        |
| 9  | Pressure switch            | 38 | Pressure switch     |
| 10 | RCV dozer                  | 39 | Pressure switch     |
| 11 | Steering valve             | 40 | Pressure switch     |
| 12 | Transmission control valve | 41 | Accumulator         |
| 13 | Brake supply valve         | 42 | Accumulator         |
| 14 | Brake valve                | 43 | Turning joint       |
| 15 | Locking valve              | 44 | Accumulator         |
| 16 | Rear axle                  | 45 | Double pedal        |
| 17 | Front axle                 | 46 | Tee shuttle         |
| 18 | Locking cylinder           | 47 | Boom swing cylinder |
| 19 | Solenoid selector          | 48 | Holding valve(LH)   |
| 20 | Tee shuttle                | 49 | Holding valve(RH)   |
| 21 | Arm cylinder               | 50 | Adjust cylinder(LH) |
| 22 | Bucket cylinder            | 51 | Adjust cylinder(RH) |
| 23 | Boom cylinder              | 52 | Decel cylinder      |
| 24 | Blade cylinder             | 53 | Transmission        |
| 25 | Blade cylinder             | 54 | Pressure switch     |
| 26 | Strainer                   | 55 | 5 cartridge valve   |
| 27 | Bypass valve               | 56 | Divert valve        |
| 28 | Return filter              | 57 | Relief valve        |
| 29 | Tee shuttle                |    |                     |