

GROUP 6 ACCELERATOR PEDAL

1. STRUCTURE

The casing has the oil inlet port A(Primary pressure), and the oil return port T(Tank). In addition the secondary pressure is taken out through port P.

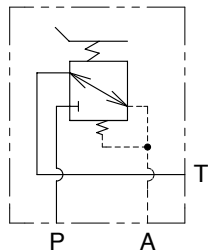
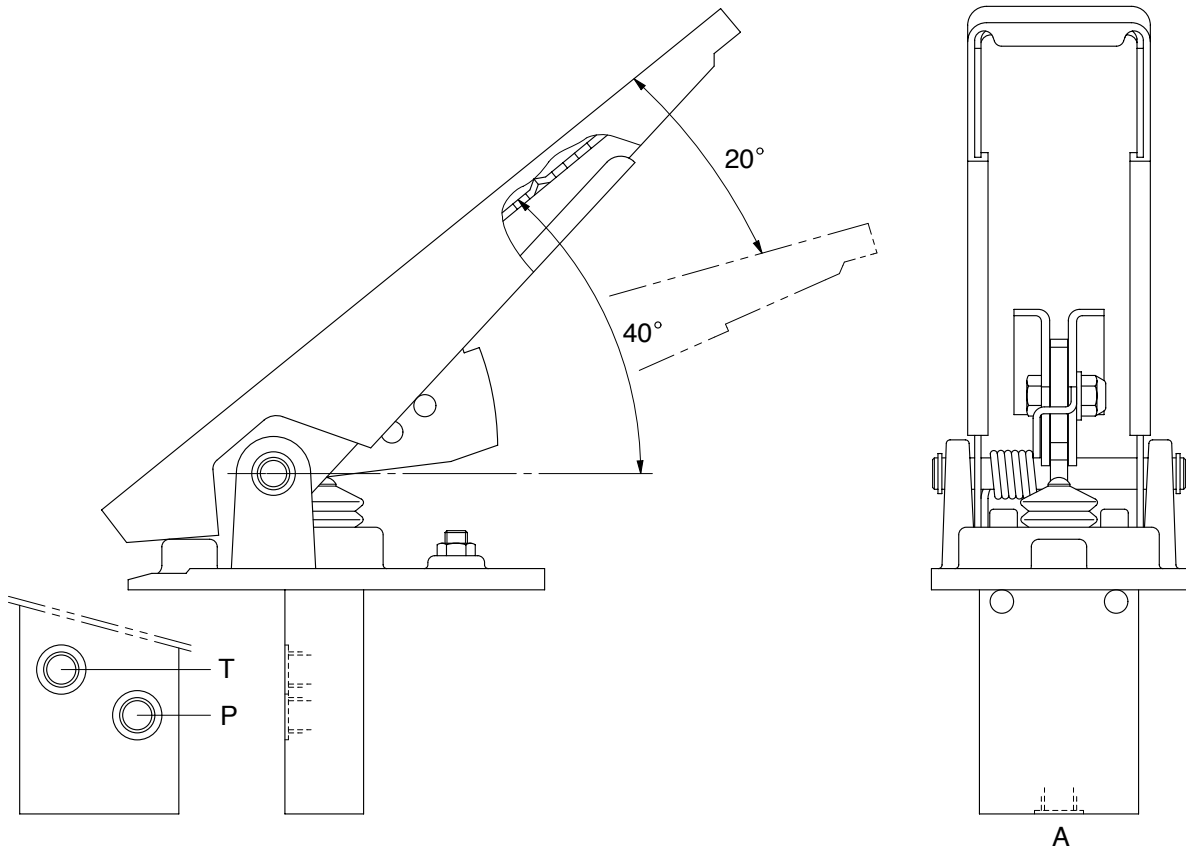

Hydraulic circuit

Port	Port name	Port size
A	Pilot oil inlet port	PF 1/4
T	Pilot oil return port	
P	Pilot oil output port	

2. COMPONENT

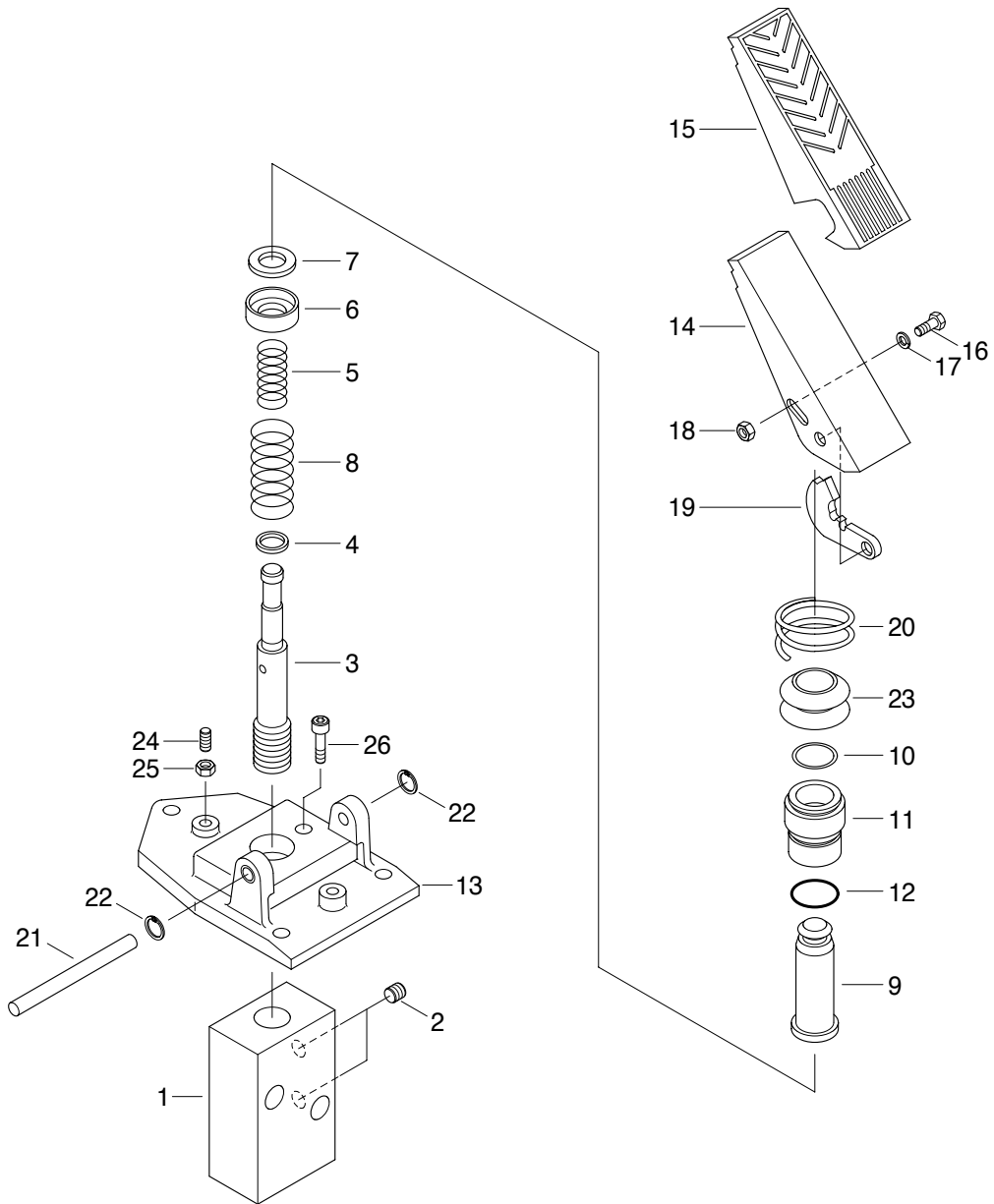

- | | | | | | |
|---|-------------|----|--------------|----|---------------------|
| 1 | Body | 10 | Rod seal | 19 | Yoke |
| 2 | Plug | 11 | Plug | 20 | Spring |
| 3 | Spool | 12 | O-ring | 21 | Guide pin |
| 4 | Spring seat | 13 | Plate | 22 | Snap ring |
| 5 | Spring | 14 | Pedal | 23 | Bellows |
| 6 | Spring seat | 15 | Pedal cover | 24 | Set screw |
| 7 | Stopper | 16 | Hexagon bolt | 25 | Nut |
| 8 | Spring | 17 | Washer | 26 | Hexagon socket bolt |
| 9 | Push rod | 18 | Nut | | |