

## GROUP 6 TRAVEL MOTOR

### 1. REMOVAL AND INSTALL

#### 1) REMOVAL

- (1) Lower the work equipment to the ground and stop the engine.
- (2) Operate the control levers and pedals several times to release the remaining pressure in the hydraulic piping.
- (3) Loosen the breather slowly to release the pressure inside the hydraulic tank.

**▲ Escaping fluid under pressure can penetrate the skin causing serious injury.**

- (4) Loosen the socket stud (1) and remove the pipe assy (2).
  - (5) Disconnect hoses (3,4,5).
  - (6) Loosen the hex bolt (6) and remove travel motor (7).
    - Weight : 80 kg (180 lb)
- ※ When removing the travel motor assembly, check that all the hoses have been disconnected.

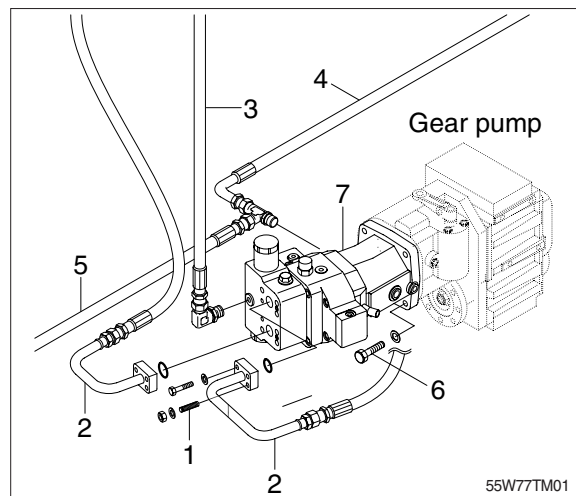

#### 2) INSTALL

- (1) Carry out installation in the reverse order to removal.
- (2) Confirm the hydraulic oil level and check the hydraulic oil leak or not.

## 2. STRUCTURE

### 1) MOTOR UNIT

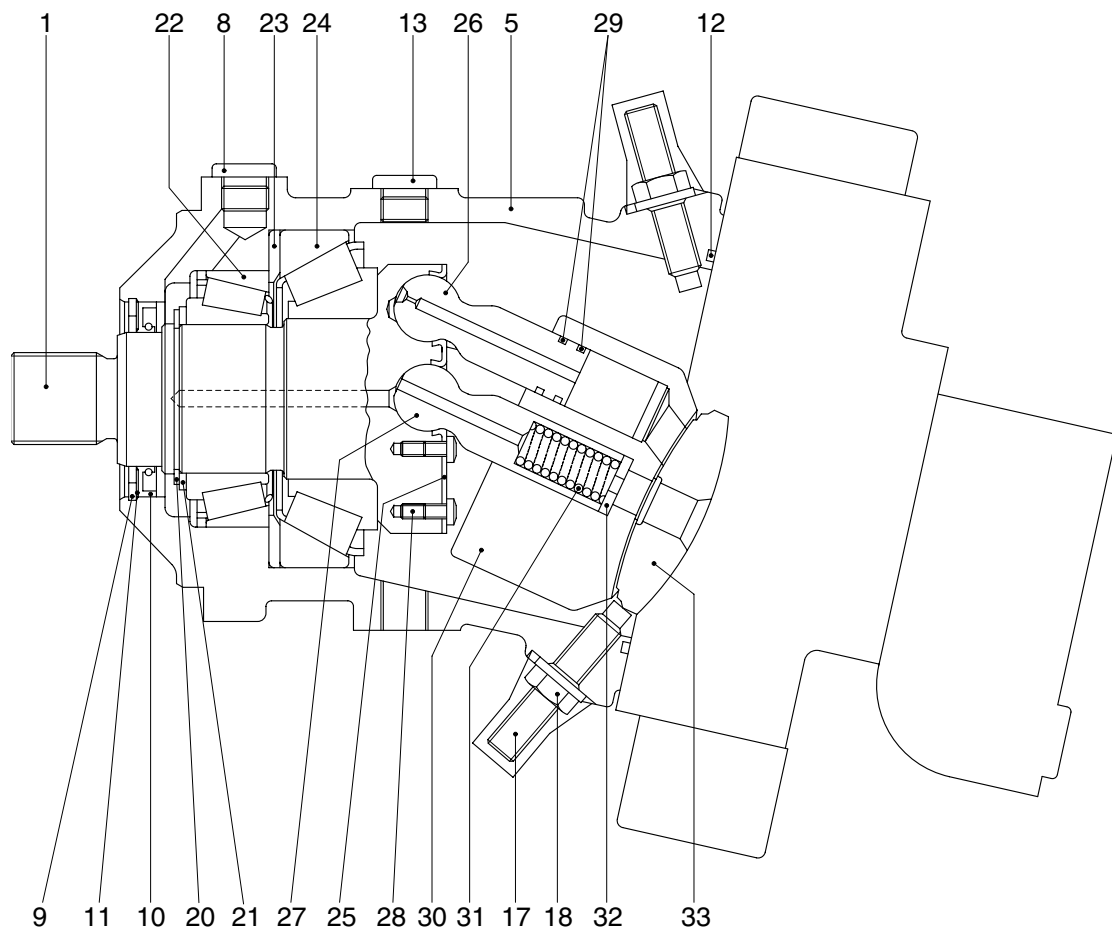

200W34TM02

1	Drive shaft	17	Threaded pin	26	Piston
5	Housing	18	Seal lock nut	27	Center pin
8	Locking screw	20	Retaining ring	28	Pan head screw
9	Retaining ring	21	Back up plate	29	Steel sealing ring
10	Shaft seal ring	22	Taper roller bearing	30	Cylinder block
11	Back up plate	23	Shim	31	Pressure spring
12	O-ring	24	Taper roller bearing	32	Adjustment shim
13	Locking screw	25	Retaining plate	33	Control lens

## 2) CONTROL UNIT

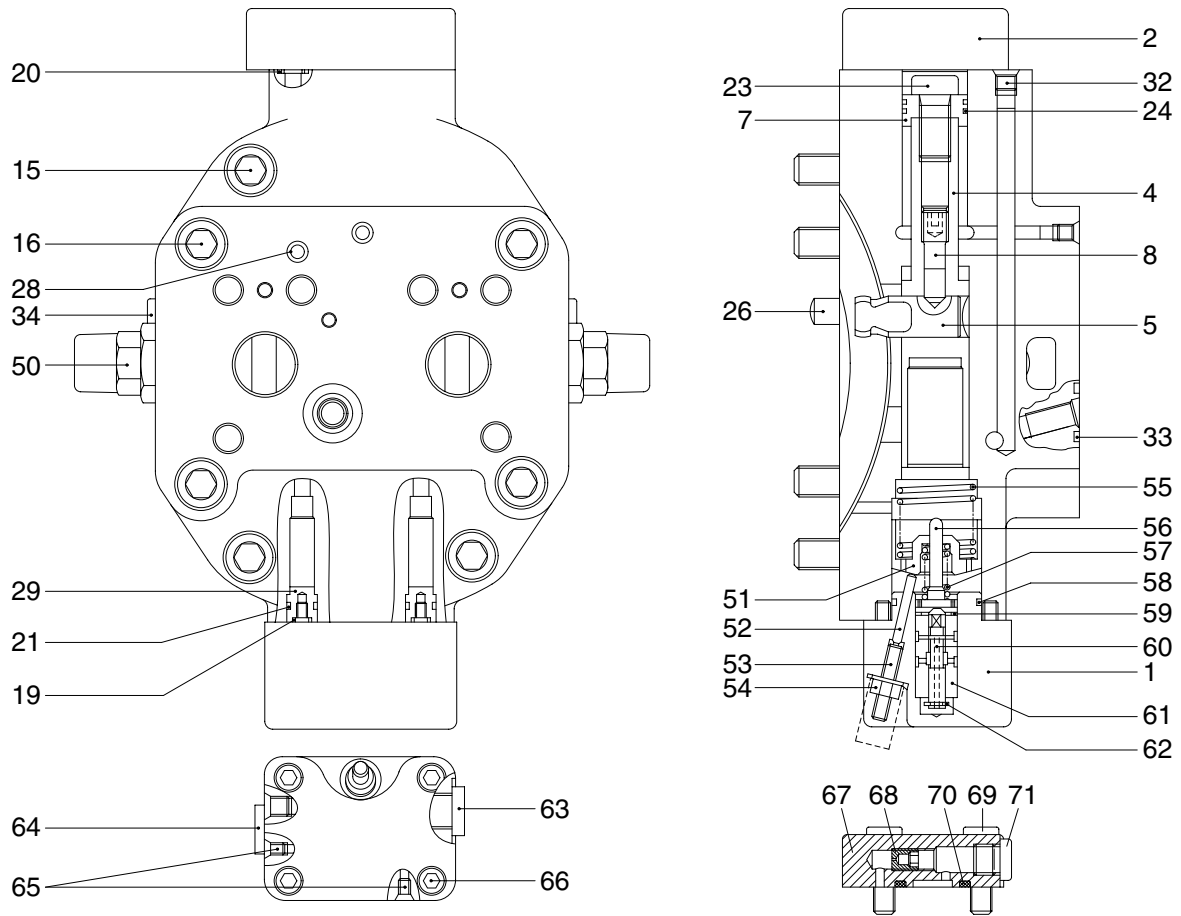

55W72TM03

1	Control housing	28	Double break off pin	59	Retaining ring
2	Cover	29	Plug	60	Control piston
4	Positioning piston	32	Double break off pin	61	Control bushing
5	Positioning trunnion	33	O-ring	62	Retaining disc
7	Piston	34	Locking screw	63	Locking screw
8	Threaded pin	50	Relief valve	64	Locking screw
15	Socket head screw	51	Adjusting bushing	65	Double break off pin
16	Socket head screw	52	Cylinder pin	66	Socket head screw
19	O-ring	53	Threaded pin	67	Cover
20	O-ring	54	Seal lock nut	68	Throttle screw
21	O-ring	55	Pressure spring	69	Socket head screw
23	Socket head screw	56	Spring collar	70	O-ring
24	Square ring	57	Pressure spring	71	Locking screw
26	Cylinder pin	58	O-ring		

### 3) COUNTER-BALANCE VALVE

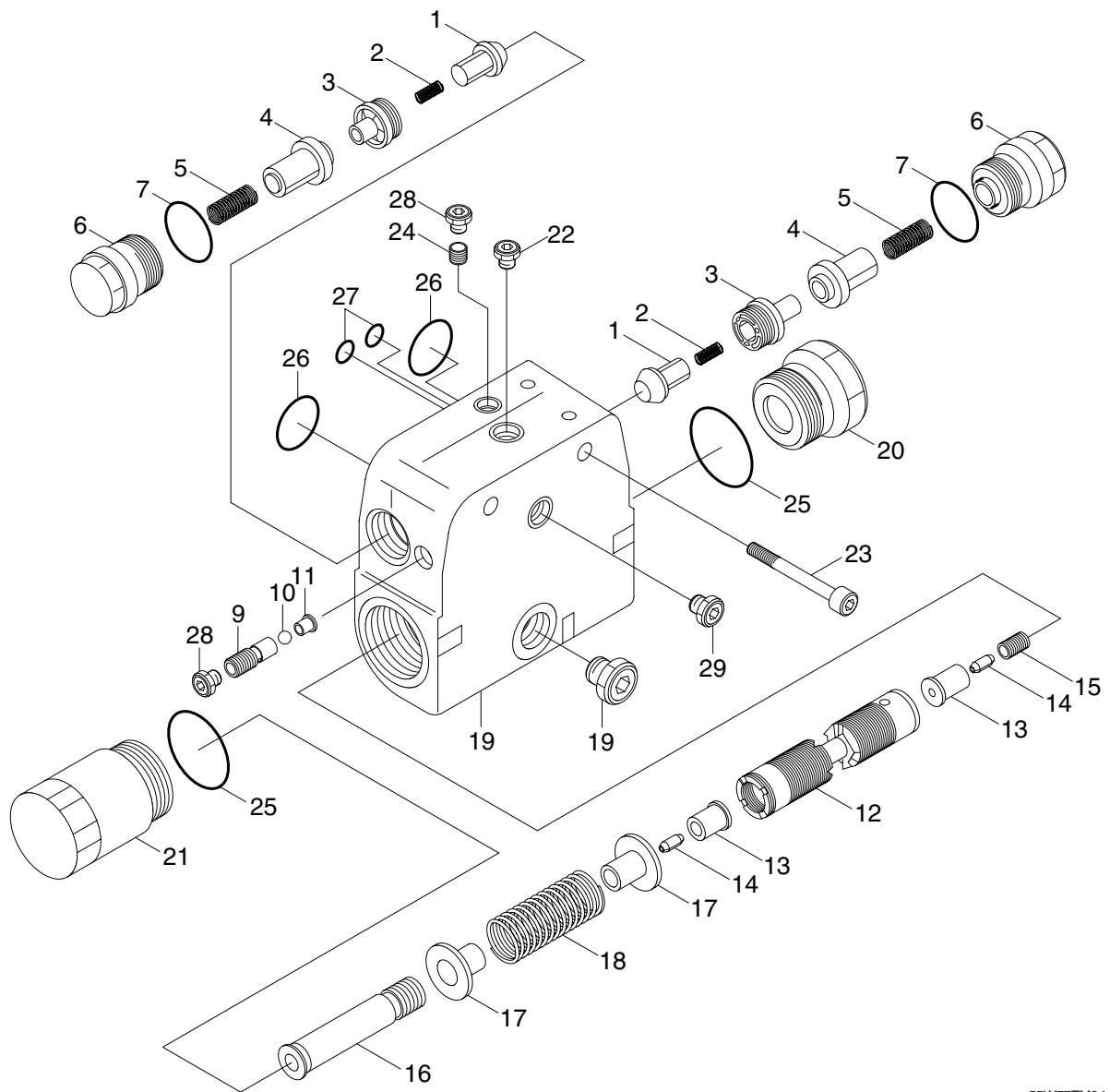

55W77TM04

- |    |                 |    |                 |    |                 |
|----|-----------------|----|-----------------|----|-----------------|
| 1  | Valve poppet    | 12 | Brake piston    | 21 | Locking screw   |
| 2  | Pressure spring | 13 | Valve bushing   | 22 | Locking screw   |
| 3  | Poppet seat     | 14 | Throttle pin    | 23 | Socket screw    |
| 4  | Valve poppet    | 15 | Valve screw     | 24 | Plug            |
| 5  | Pressure spring | 16 | Bolt            | 25 | O-ring          |
| 6  | Locking screw   | 17 | Spring collar   | 26 | O-ring          |
| 7  | O-ring          | 18 | Pressure spring | 27 | O-ring          |
| 9  | Valve screw     | 19 | Housing         | 28 | Locking screw   |
| 10 | Ball            | 20 | Locking screw   | 29 | D/Break OFF pin |
| 11 | Bushing         |    |                 |    |                 |

### 3. TIGHTENING TORQUE

The torques given are standard figures. Any figures specifically described in the procedure has priority.

Page	Item	Size	kgf · m	lbf · ft
8-75	8	M22 × 1.5	6.1	44
	13	M26 × 1.5	7.1	51
	18	M12	7.0	50.9
	28	M 6 × 20	1.4	10.3
8-76	15	M16 × 45	21.4	155
	23	M14 × 25	13.8	99.5
	34	M18 × 1.5	4.0	29
	53	M 6 × 30	1.4	10.3
	54	M6	1.0	7.4
	63	M14 × 1.5	3.0	22
	66	M 8 × 40	2.5	18.4
	69	M12 × 35	12.2	88.4
	71	M14 × 1.5	3.0	22

## 4. DISASSEMBLY AND ASSEMBLY

### 1) GENERAL PRECAUTIONS

#### (1) Disassembly

- ① Before disassembling the motor, check the items to be inspected and, for remedy against trouble, closely examine the nature of the trouble, so that the motor can be disassembled effectively.
- ② To disassemble the motor, use the disassembling procedures described in section 2) and select a clean place.
- ③ Place a rubber or vinyl sheet or other such protective materials on your working bench to protect the surface of the motor to be serviced.
- ④ During disassembly, give a match mark to the mating surfaces of each part.
- ⑤ Arrange removed parts in order so that they will not become damaged or missing during disassembly.
- ⑥ Once seals have been disassembled, they should be replaced even if damage is not observed. Have replacement seals ready on hand before starting your disassembling job.

#### (2) Assembly

- ① Reassemble in a work area that is clean and free from dust and grit.
- ② Handle parts with bare hands to keep them free of linty contaminants.
- ③ Repair or replace the damaged parts.  
Each parts must be free of burrs its corners.
- ④ Do not reuse O-ring oil seal and floating seal that were removed in disassembly.  
Provide the new parts.
- ⑤ Wash all parts thoroughly in a suitable solvent.  
Dry thoroughly with compressed air.  
Do not use the cloths.
- ⑥ When reassembling oil motor components of motor, be sure to coat the sliding parts of the motor and valve with fresh hydraulic oil. (NAS class 9 or above)
- ⑦ Use a torque wrench to tighten bolts and plugs, to the torque specified as follows.

## 2) SEAL KITS AND COMPONENT GROUPS

Observe the following notices when carrying out repair work at hydraulic aggregates.



- (1) Close all ports of the hydraulic aggregates.

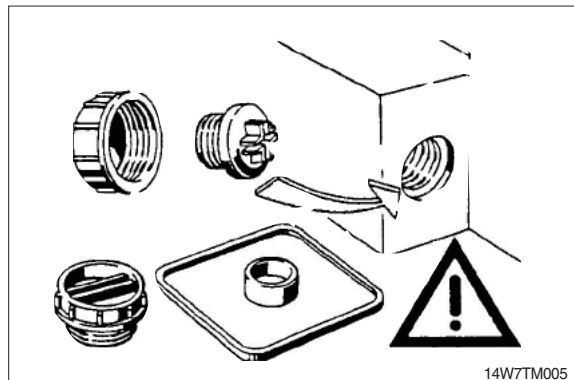

- (2) Replace all seals.  
Use only original hydromatik spare parts.

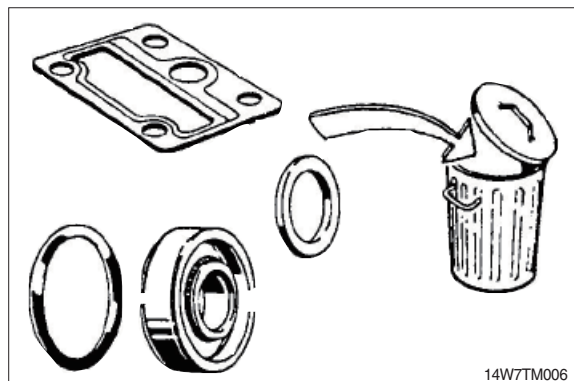

- (3) Check all seal and sliding surfaces for wear.  
※ Rework of sealing area f.ex. with abrasive paper can damage surface.

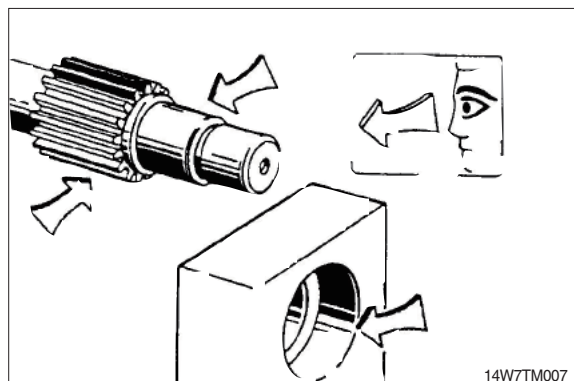

- (4) Fill up hydraulic aggregates with hydraulic oil before start up.

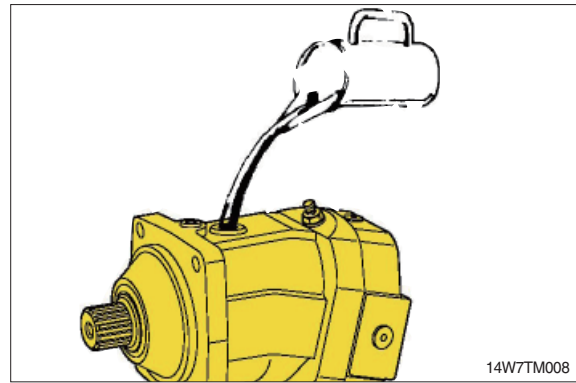

- (5) Seal kit for drive shaft

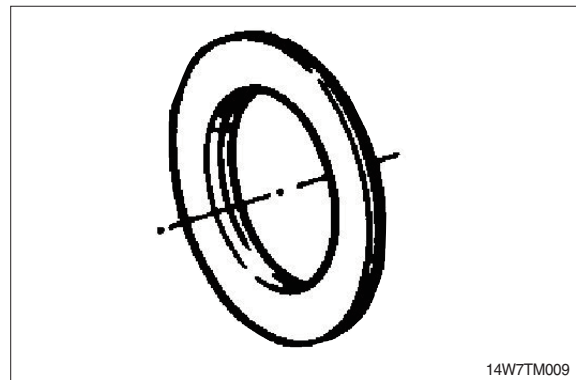

- (6) External seal kit.

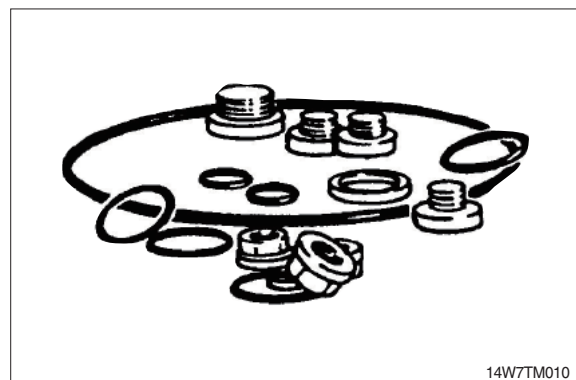

- (7) Housing.

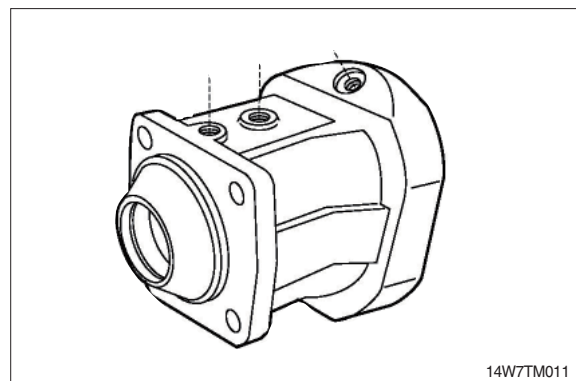

(8) Complete rotary group.

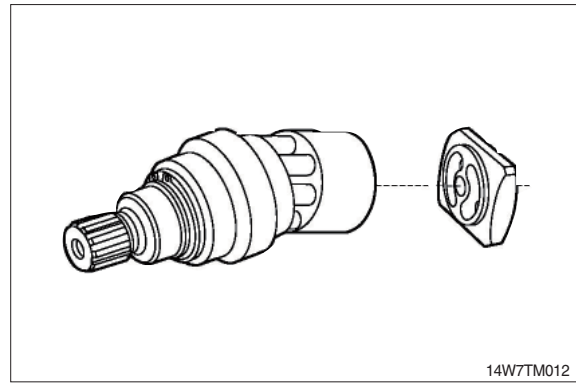

(9) Port plate with control piston.

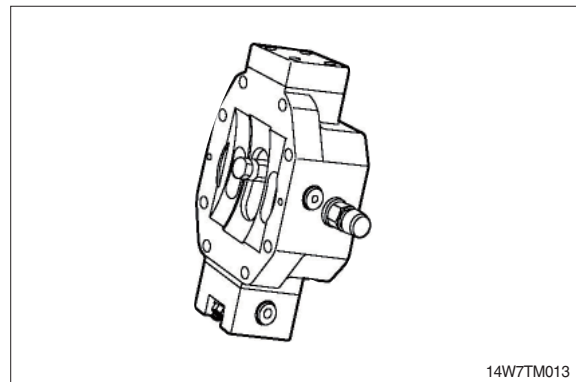

(10) Counter balance valve.

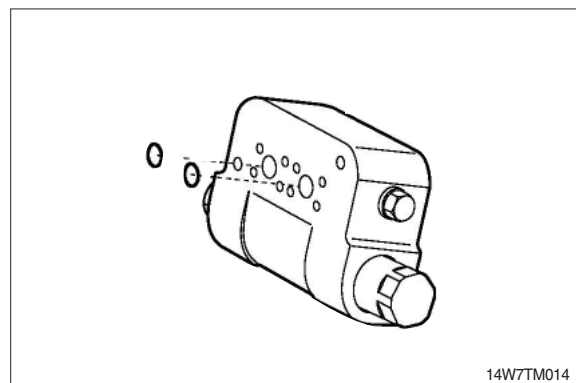

(11) Relief valve / Make up check valve.

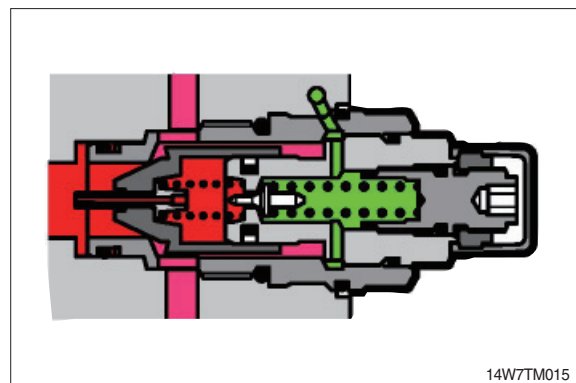

### 3) SEAL NUT

- (1) Replace seal nut.  
First measure and record setting height.

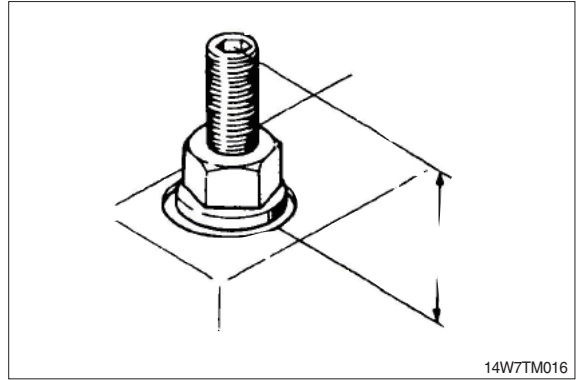

- (2) When tightening, counterhold setting screw, then check setting height.

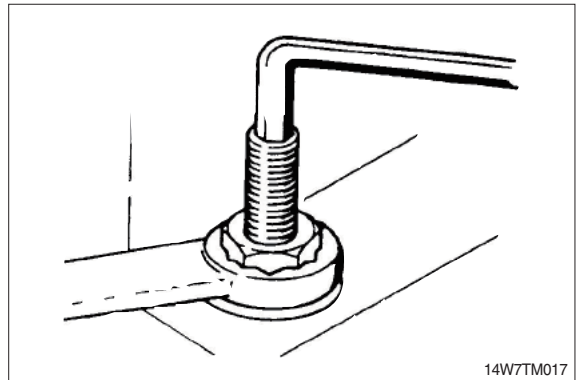

#### 4) SEALING THE DRIVE SHAFT

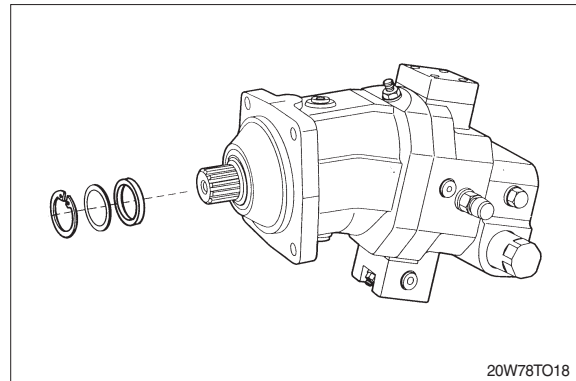

- (1) Protecting the drive shaft.  
Remove retaining ring and shim.

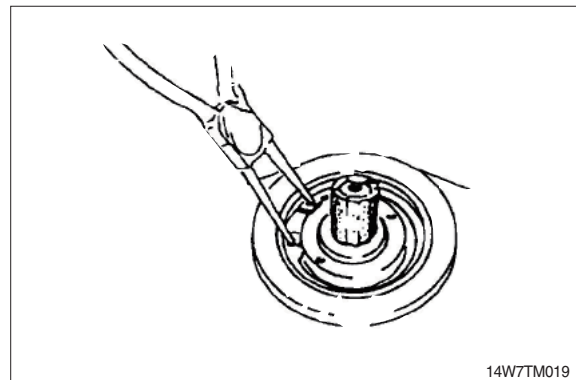

- (2) Screw in sheet metal screw into the holes fitted with rubber.  
Pull out seal with pliers.

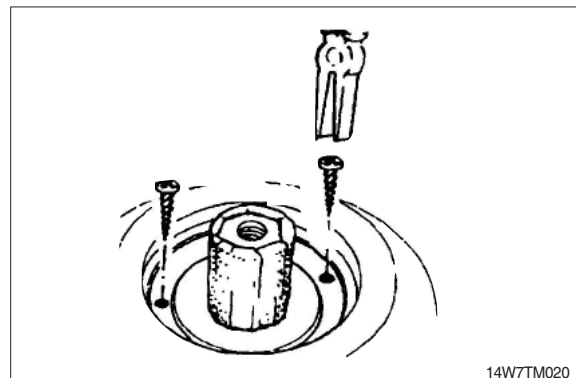

- (3) Press in shaft seal and shim with bush to stop.

**▲ Pay attention to pressing depth.**

\* Mark for pressing depth.

Assemble retaining ring.

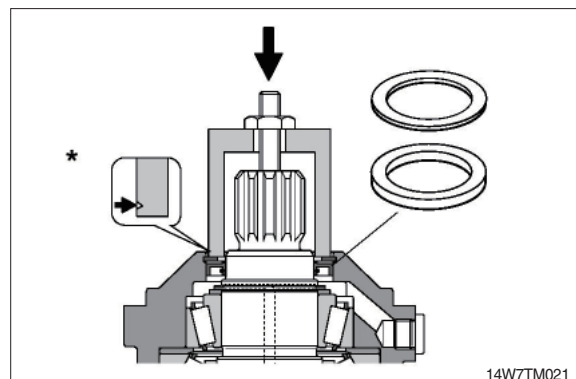

## 5) SEALING OF THE CONTROL PARTS

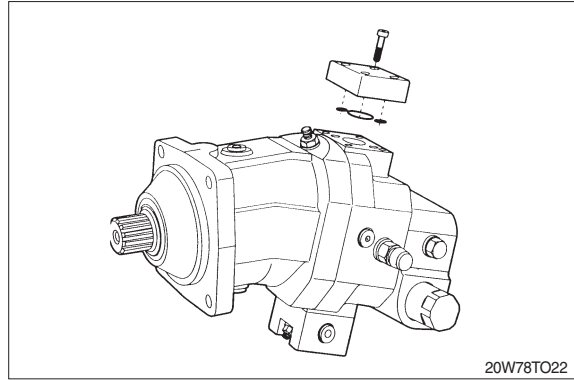

### (1) Disassembly position

Remove cover 1.

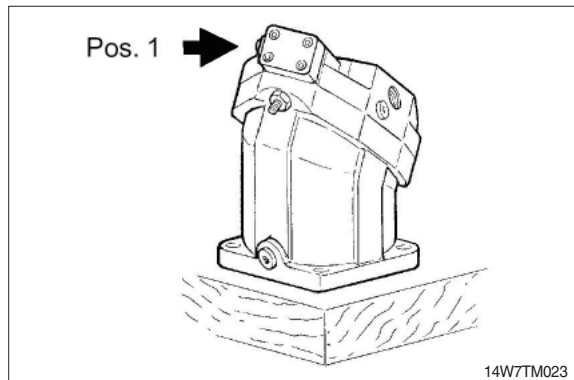

- 1 O-ring
- 2 Input flow of oil control
- 3 Throttle pin

※ Installation position differs according to the control components.

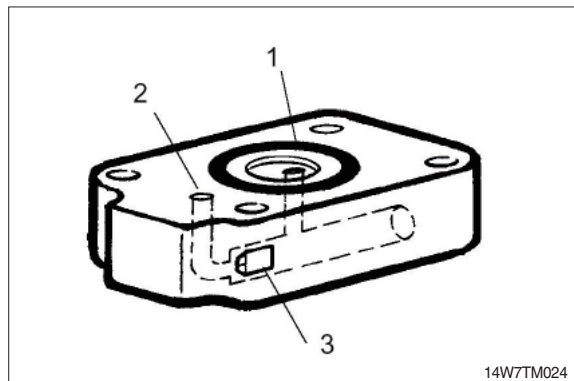

- 1 Input flow of oil control
- 2 High pressure / Low pressure
- 3 High pressure / Low pressure
- 4 Leakage oil
- 5 Control piston

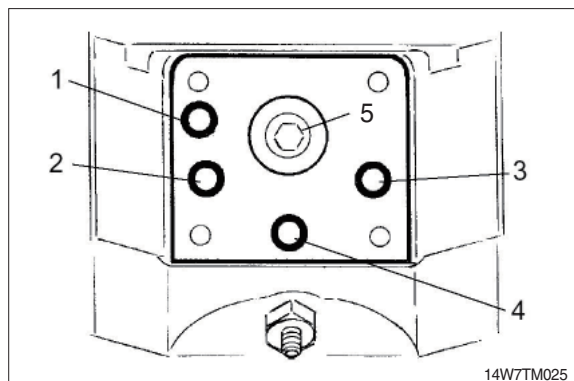

- (2) Disassembly position : Remove cover 2.
- ※ Attention spring load.

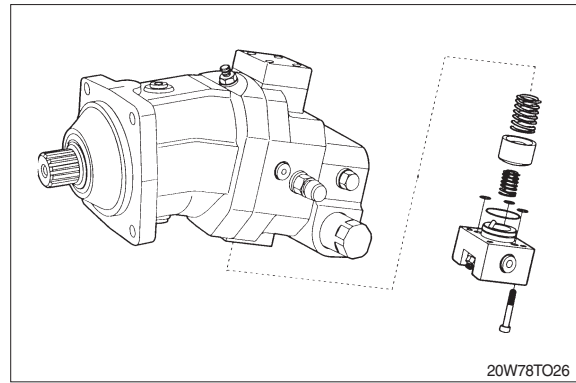

20W78TO26

- ※ Dimension X : Note dimension (begin of regulation)

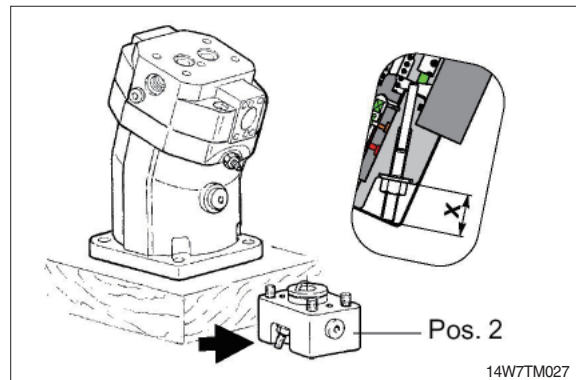

14W7TM027

- 1 Check of O-ring

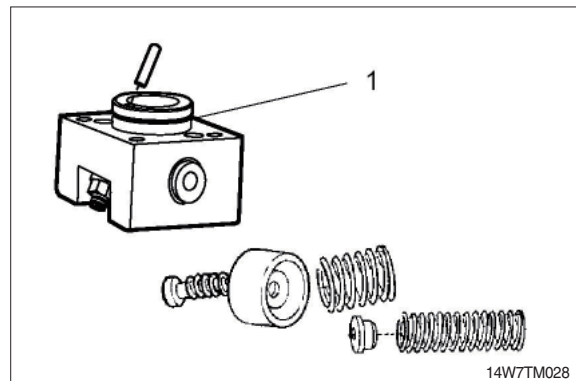

14W7TM028

- 1 O-ring / High pressure-small control position side
- 2 O-ring / Control pressure
- 3 O-ring / High pressure-check valve
- 4 O-ring / High pressure-check valve

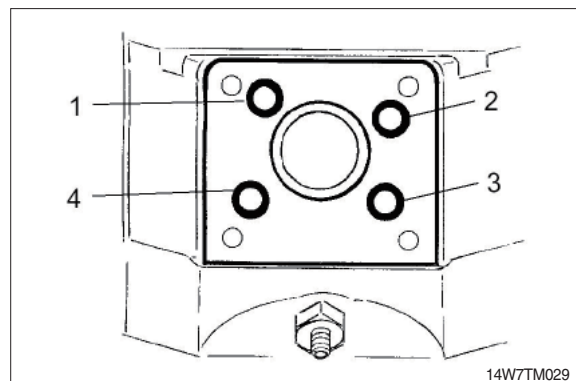

14W7TM029

## 6) SEALING OF THE RELIEF VALVE / COUNTER BALANCE VALVE

- Remove counter balance valve
- Inspect
- O-ring

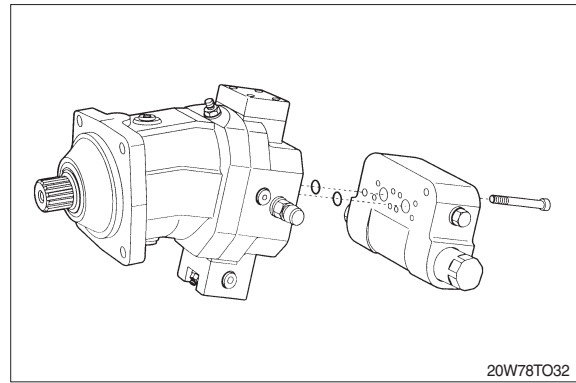

(1) Remove relief valve

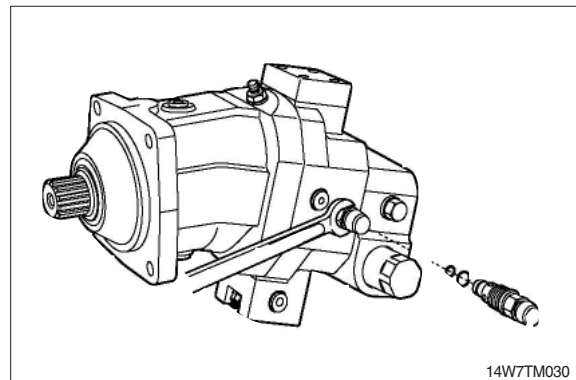

(2) Inspect  
O-ring

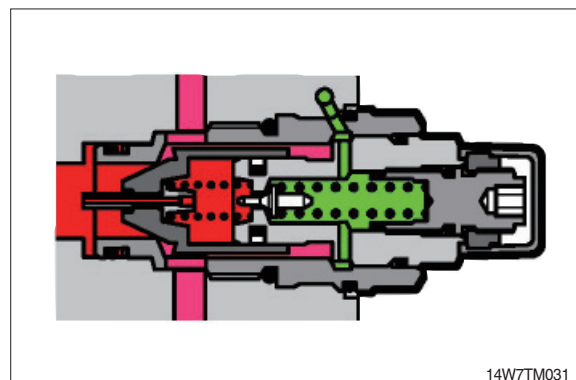

(3) Remove counter-balance valve.  
Inspect  
O-ring

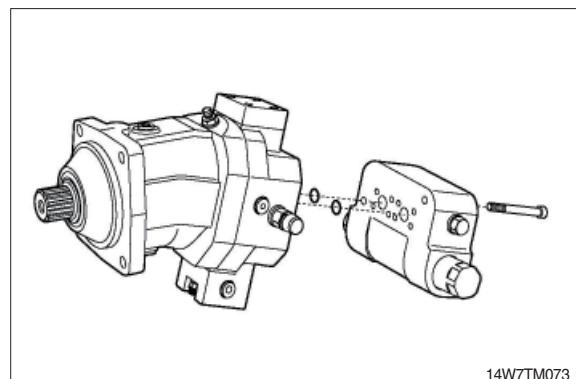

## 7) DISASSEMBLY OF THE PORT PLATE

- Note dimension X
- Remove  $Q_{min}$  screw
- Swivel rotary group to zero P

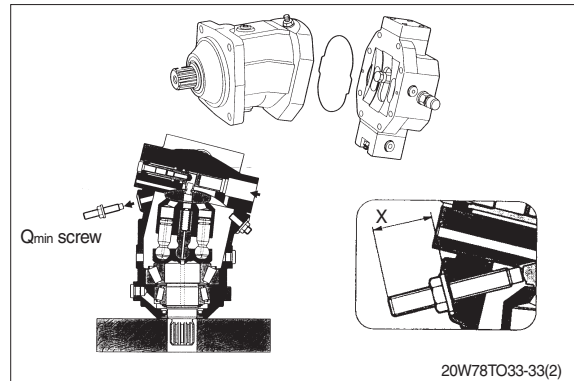

- (1) Port plate.  
Mark position. Loosen screws.  
Removal.

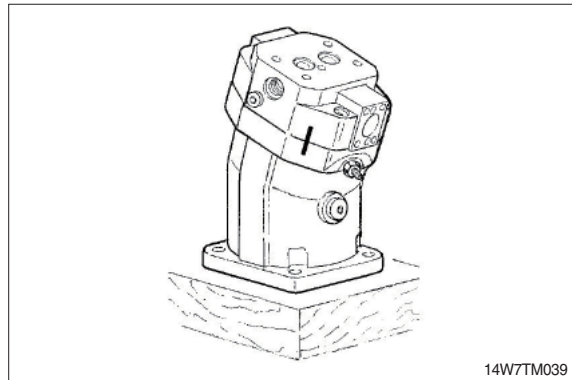

- (2) Check O-ring.  
※ Stick new O-ring with some grease.  
Do not swivel rotary group.  
Piston rings to hang out from the cylinder boring.

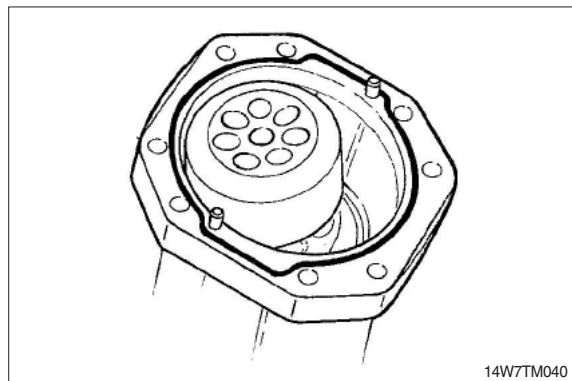

## 8) REMOVE OF THE POSITIONING PISTON

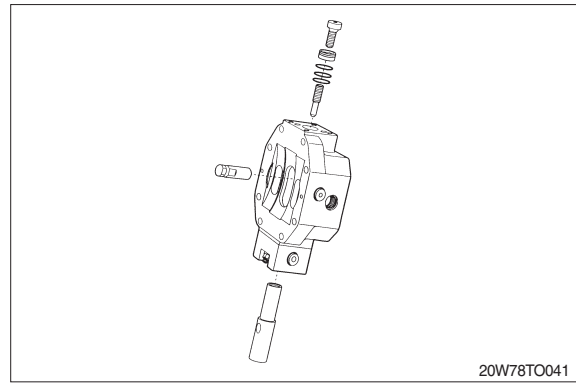

- (1) Loosen fixing screw.  
Use only socket wrench.

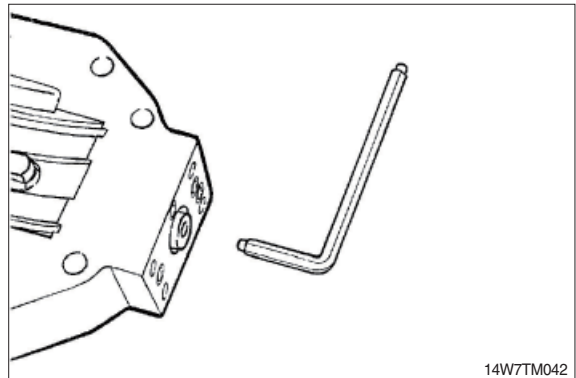

- (2) Remove piston with piston ring.

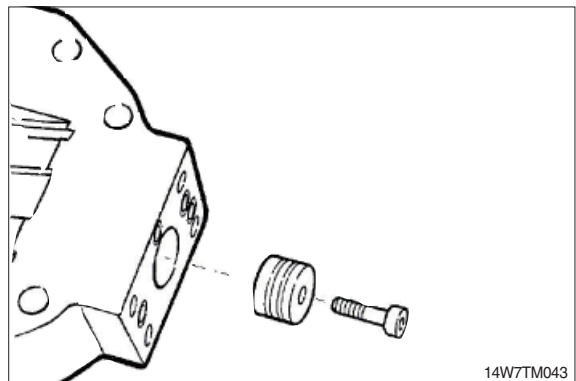

- (3) Warm up fixation screw \*for positioning plug via boring (screw glued-to turn out).  
※ Use new screw.  
Precode coating.  
Note tightening torque.

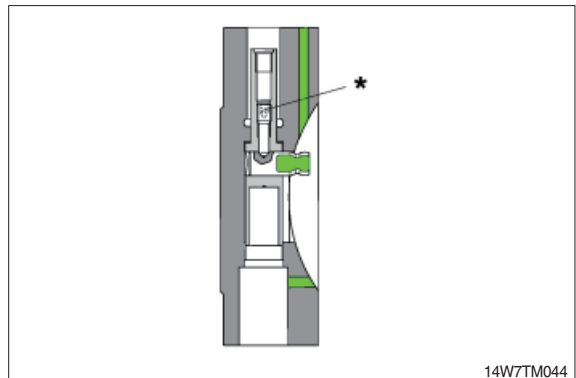

- ※ Stick control lens in sliding surface with grease. Assembly in reversal order. Mount port plate.
- ※ Rotary group vertical.

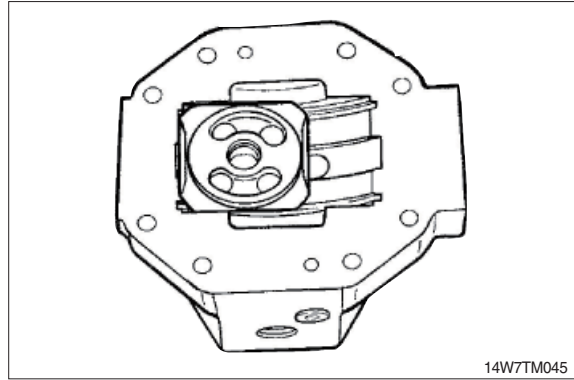

## 9) REMOVE ROTARY GROUP

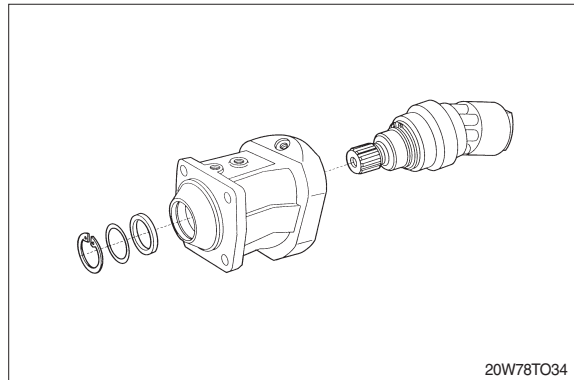

- (1) Screw in threaded pin into center pin.  
Fix the cylinder with disc and locknut.  
M8 × 105 l

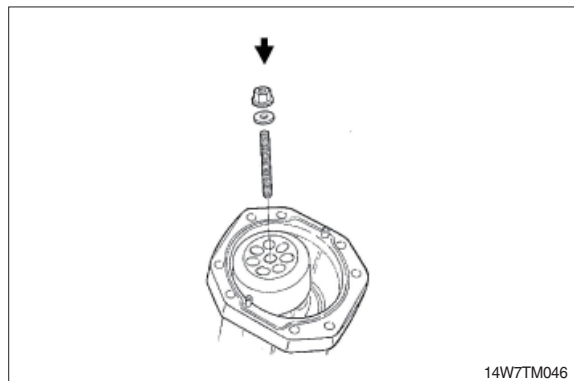

- (2) Press out rotary group.
  - ※ If the bearings are used again do not hit on the drive shaft.

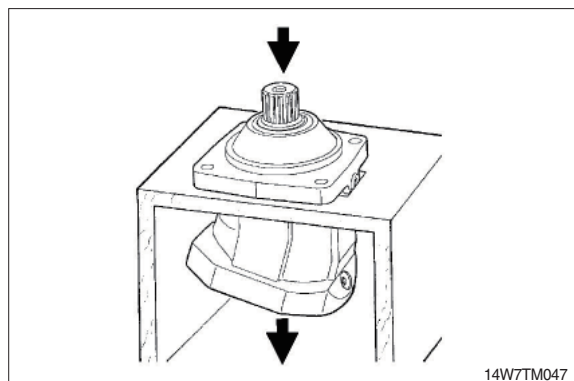

## 10) EXCHANGING OF THE ROTARY GROUP

Complete rotary group

※ Setting of hydraulic part necessary.

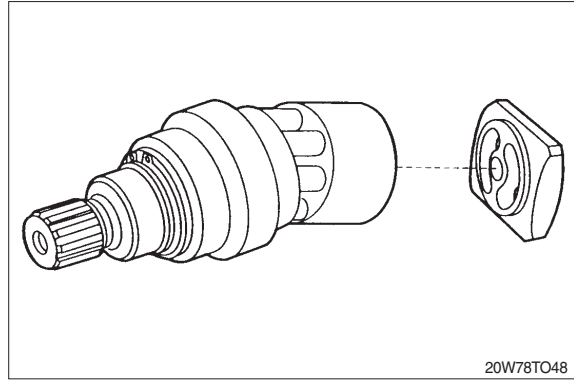

### Rotary group

1 Mechanical part : Adjust drive shaft with bearing

2 Hydraulic part : Adjustment necessary

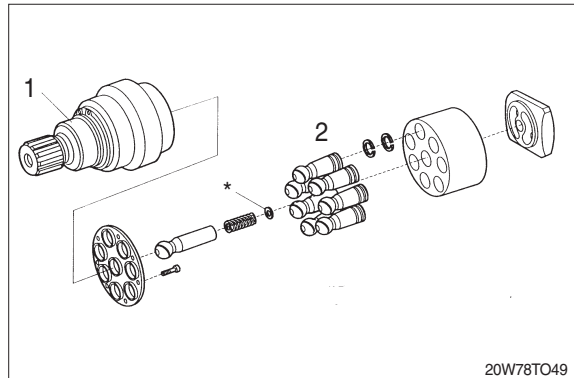

(1) Remove fixing screw (cylinder).  
Remove cylinder.

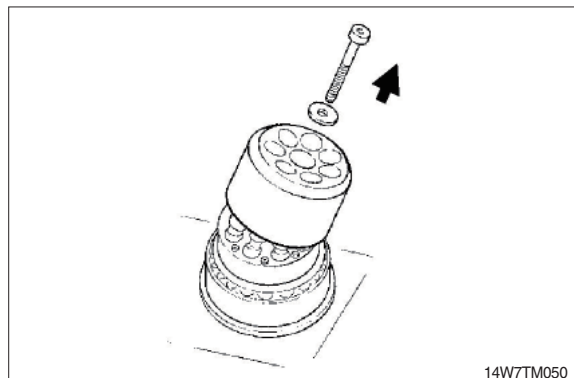

(2) Disassemble retaining plate.

※ Screws are glued.

Use Torx tools.

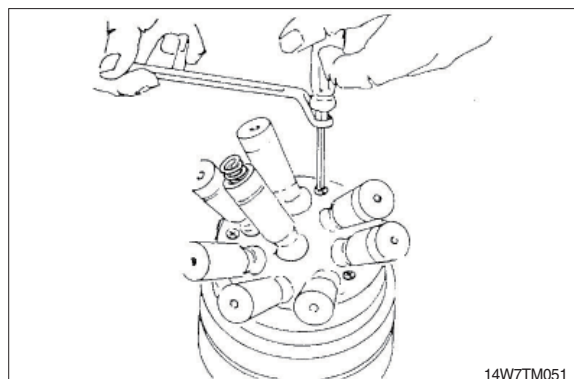

## 11) INSPECTION INSTRUCTIONS

- (1) Free of corrosion, erosion or fretting; No damage to splines or keyways.

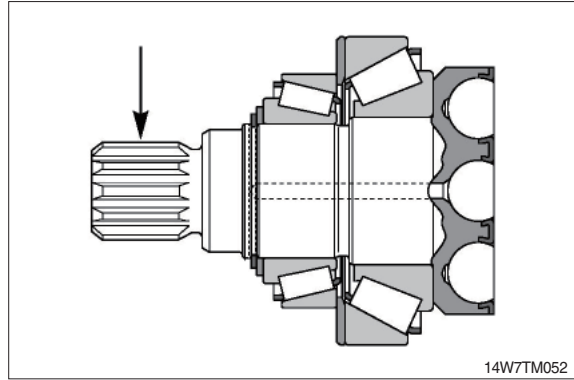

### (2) Pistons

- No scoring and no pittings.

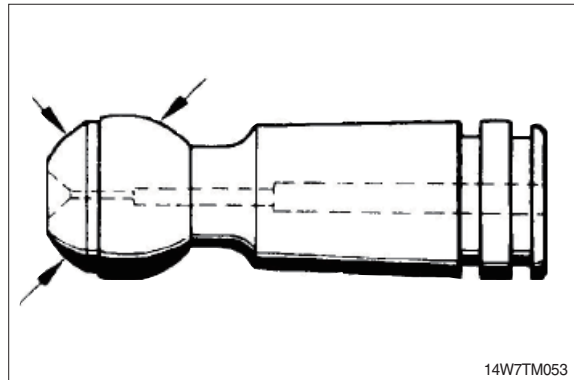

### (3) Center pin

- No scoring and no pittings.

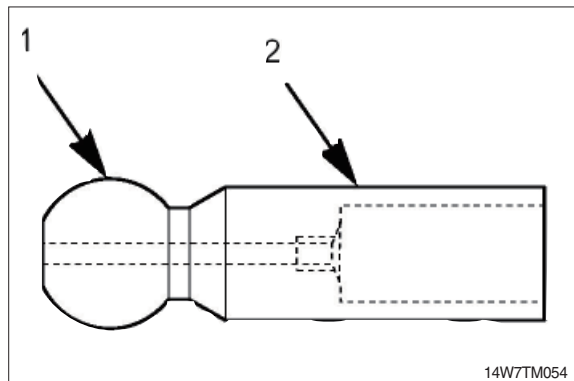

### (4) Retaining plate

- No scoring and no evidence of wear.

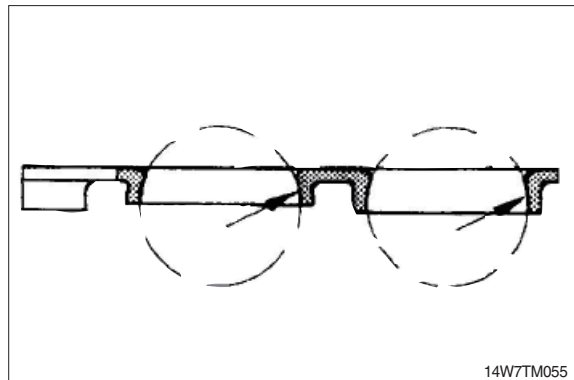

**(5) Cylinder block / Control lens**

- 1 Bores free of scoring, no evidence of wear
- 2 Faces smooth and even, free of cracks and scoring

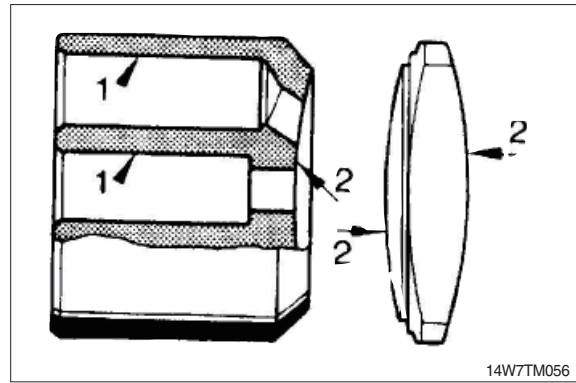

**(6) Control housing**

Sliding surface and side guides free of scoring and no wear.

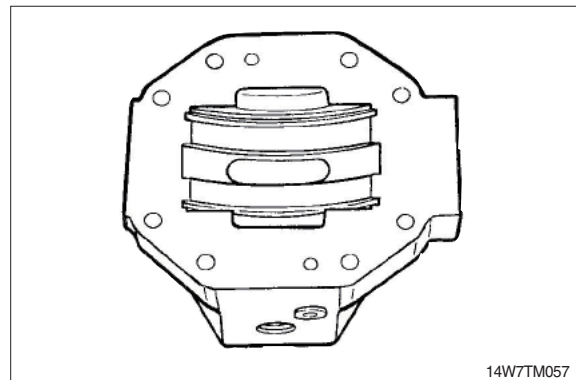

**(7) Visual check**

Bearing areas free of scoring and no evidence of wear.

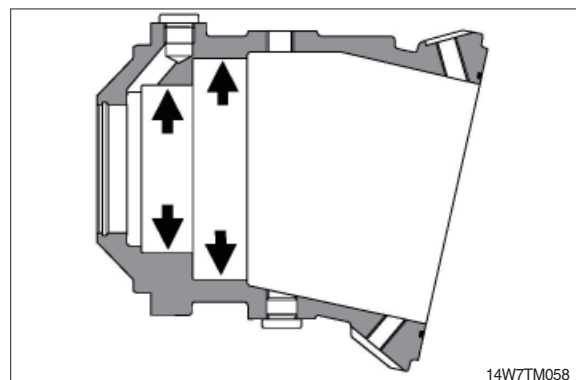

## 12) ROTARY GROUP ASSEMBLY

- (1) Rotary group completely assembled ready for assembly.

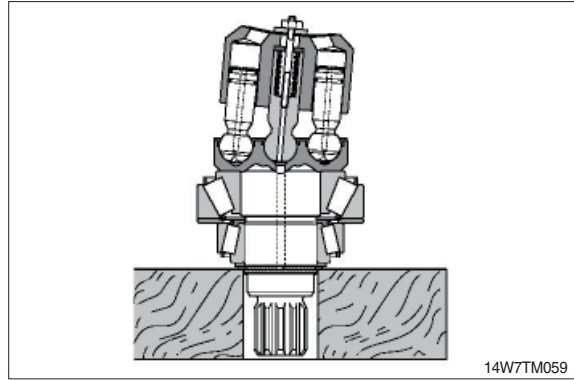

- (2) Place assembly sleeve.

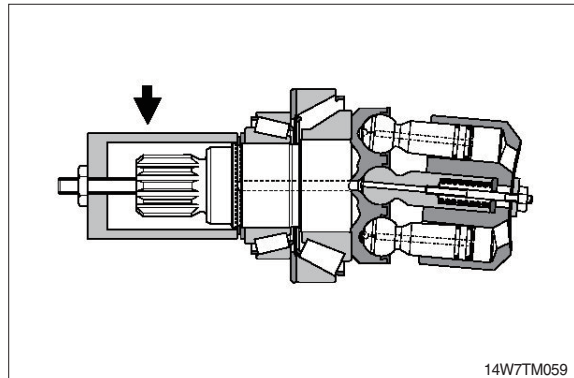

- (3) Warm up housing to 80°C.

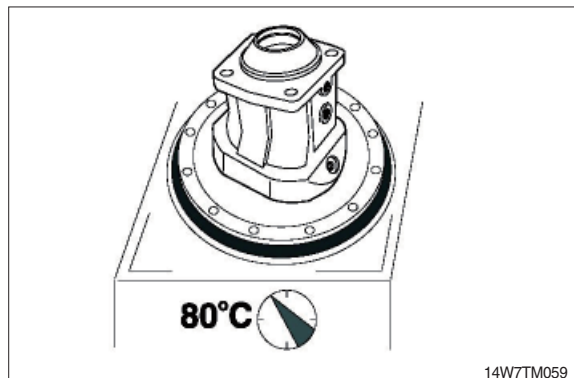

- (4) Insert rotary group into housing to seat position.

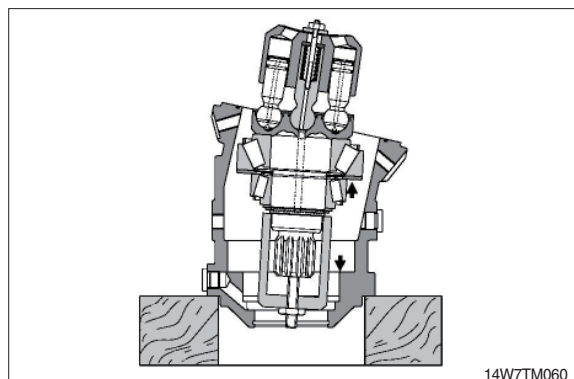

- (5) Insert rotary group into housing to seat position.

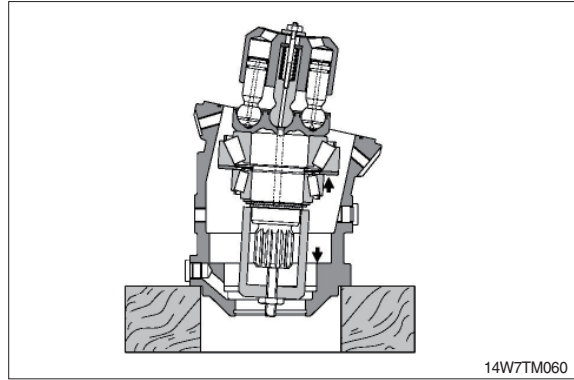

- (6) Fix zero position of cylinder with  $Q_{max}$  screw.
- 1 Disassemble cylinder fixing screw
  - 2 Insert O-ring

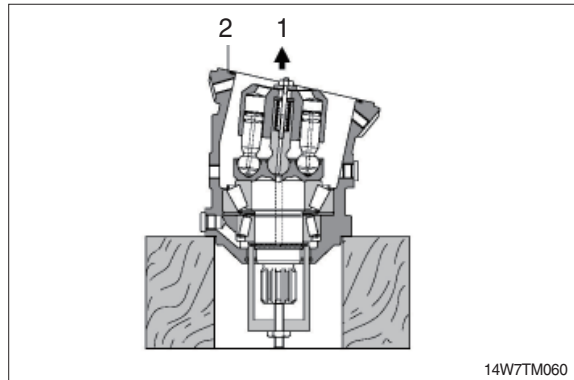

### 13) ROTARY GROUP ADJUSTMENT

- (1) Determine cylinder swivel range to max angle with screw.

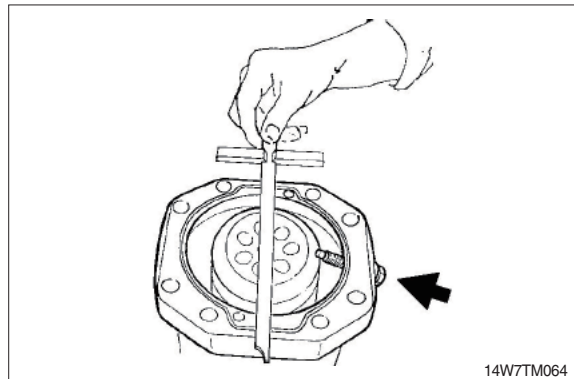

- (2) \* Disc

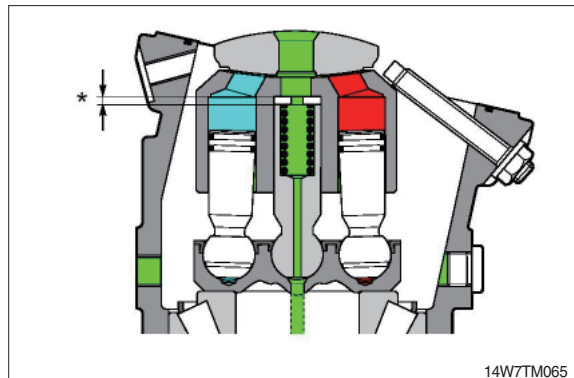

(3) Place centering disc.

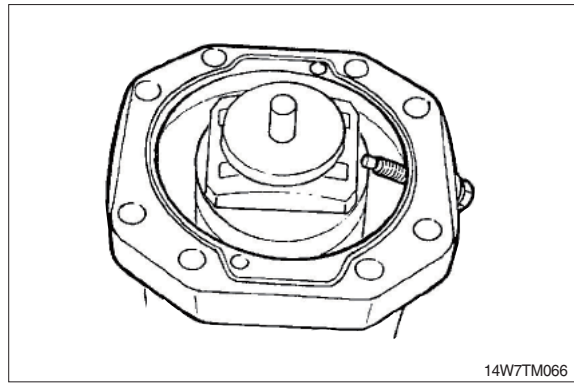

(4) Mount measuring device.

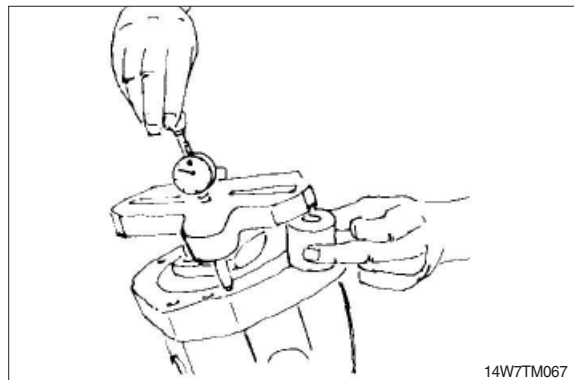

(5) Check dimension X.

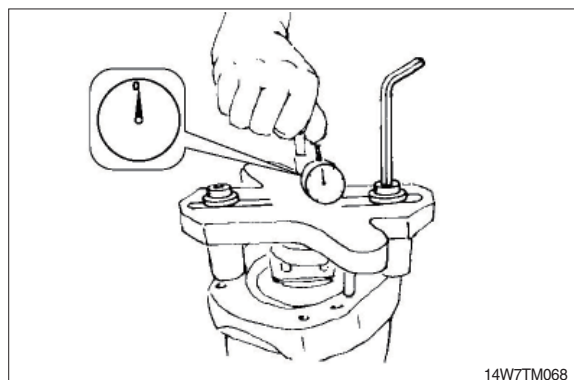

#### 14) ASSEMBLY OF THE PORT PLATE

- (1) Assemble port plate.
  - ※ Take care of assembly design.
  - Tighten fixing screws with torque.
- (2) Set  $Q_{\min}$  screw to dimension (\*).
- (3) Assemble plug.
- (4) Remove assembly sleeve.

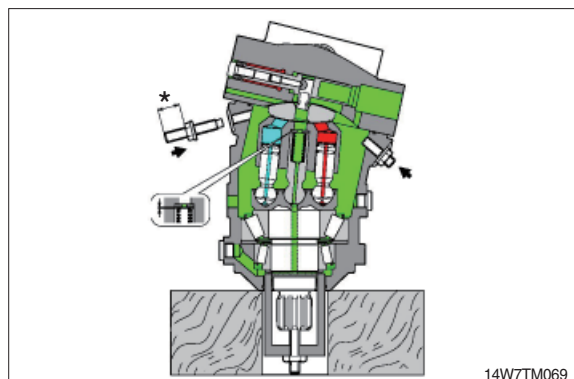

(5) Assemble control components.

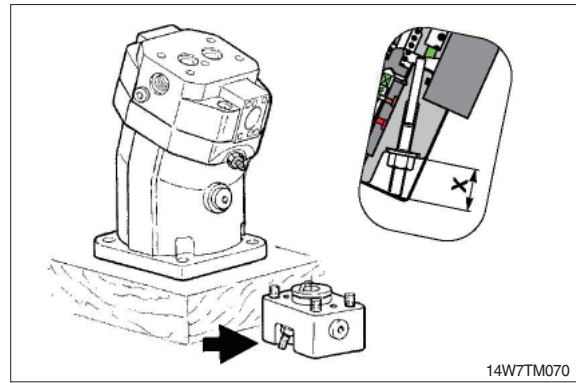

(6) Assemble cover.

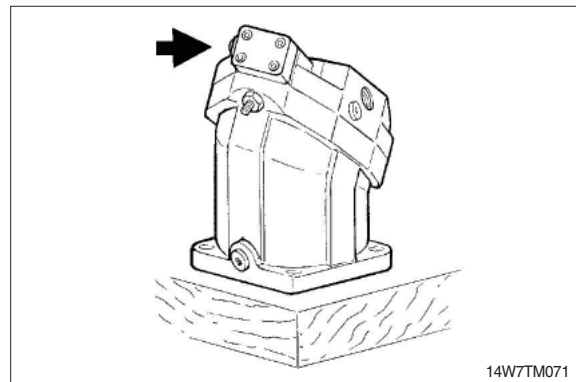

(7) Assemble shaft seal, disc and safety ring.

Press in with assembly sleeve.

※ Take care of press in depth.

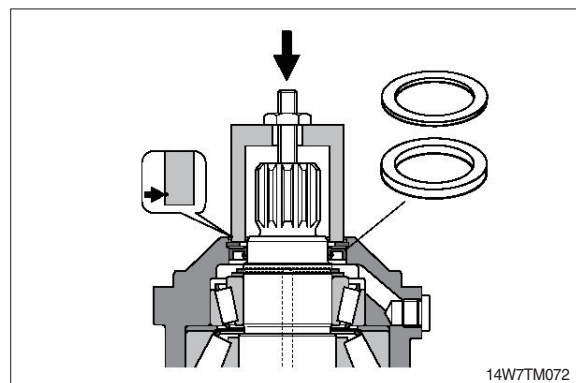

(8) Assemble counter balance valve.

