

GROUP 4 MAIN CONTROL VALVE

1. REMOVAL AND INSTALL OF MOTOR

1) REMOVAL

- (1) Lower the work equipment to the ground and stop the engine.
- (2) Operate the control levers and pedals several times to release the remaining pressure in the hydraulic piping.
- (3) Loosen the breather slowly to release the pressure inside the hydraulic tank.

▲ Escaping fluid under pressure can penetrate the skin causing serious injury.

※ When pipes and hoses are disconnected, the oil inside the piping will flow out, so catch it in oil pan.

- (4) Disconnect hydraulic hose.
- (5) Disconnect pilot line hoses.
- (6) Remove link.
- (7) Sling the control valve assembly and remove the control valve mounting bolt.
 - Weight : 40 kg (90 lb)
- (8) Remove the control valve assembly.
When removing the control valve assembly, check that all the piping have been disconnected.

2) INSTALL

- (1) Carry out installation in the reverse order to removal.
- (2) Bleed the air from below items.
 - ① Cylinder (boom, arm, bucket)
 - ② Swing motor
 - ③ Travel motor※ See each item removal and install.
- (3) Confirm the hydraulic oil level and recheck the hydraulic oil leak or not.

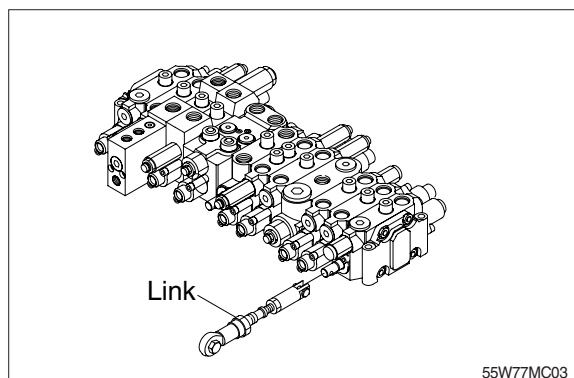
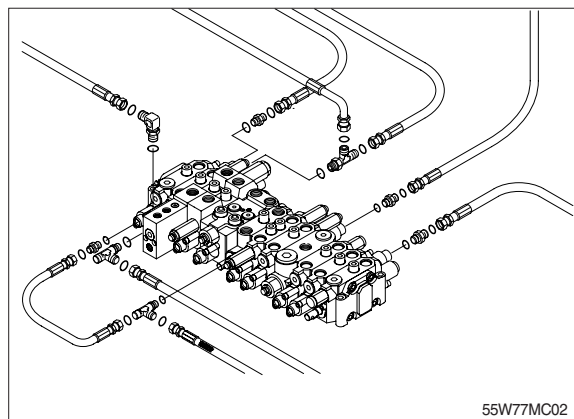
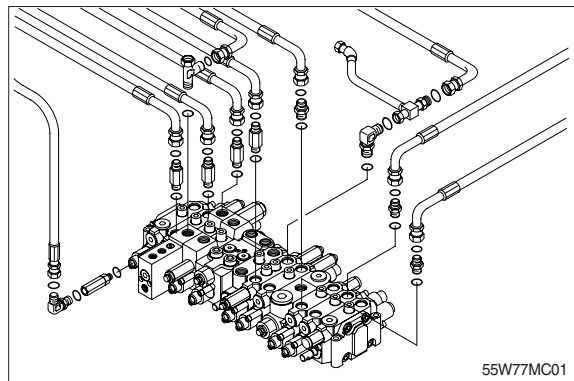

2. STRUCTURE (1/4)

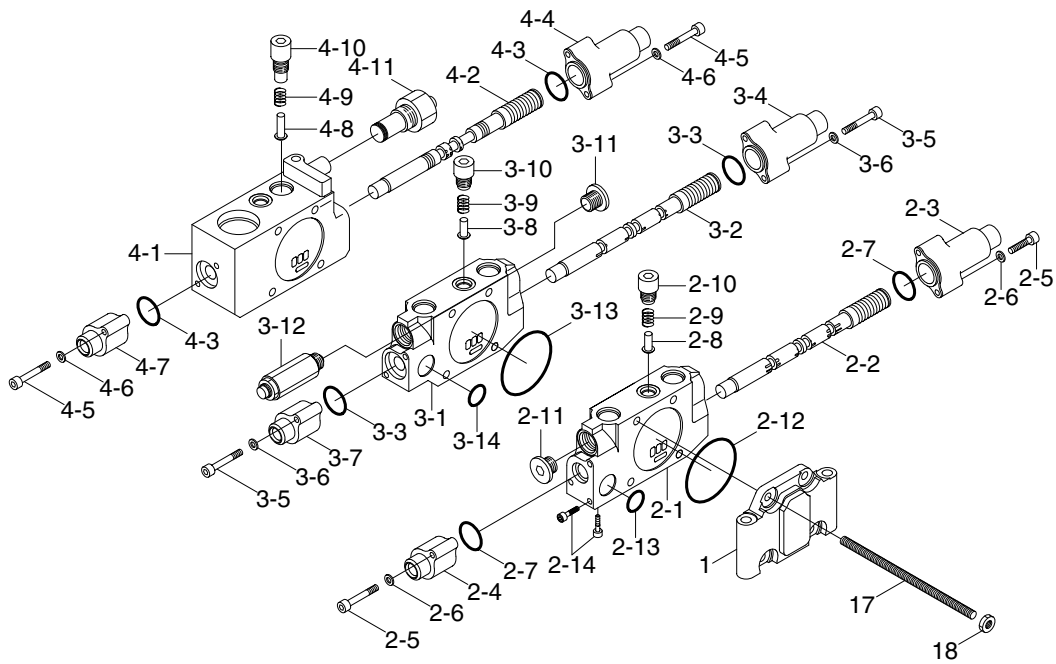

555W92MC02

1	Cover	2-14	Plug	3-14	O-ring
2	Swing block	3	Dozer block	4	Inlet block
2-1	Block	3-1	Block	4-1	Block
2-2	Swing spool assy	3-2	Dozer spool assy	4-2	Inlet spool assy
2-3	Pilot cap (A)	3-3	O-ring	4-3	O-ring
2-4	Pilot cap (B1)	3-4	Pilot cap (A)	4-4	Pilot cap (A)
2-5	Wrench bolt	3-5	Wrench bolt	4-5	Wrench bolt
2-6	Plain washer	3-6	Plain washer	4-6	Plain washer
2-7	O-ring	3-7	Cap	4-7	Pilot cap (B1)
2-8	Check poppet	3-8	Check poppet	4-8	Check poppet
2-9	Check spring	3-9	Check spring	4-9	Check spring
2-10	Plug	3-10	Plug	4-10	Plug
2-11	Plug	3-11	Plug	4-11	Main relief valve
2-12	O-ring	3-12	Check valve	17	Tie bolt
2-13	O-ring	3-13	O-ring	18	Nut

STRUCTURE (2/4)

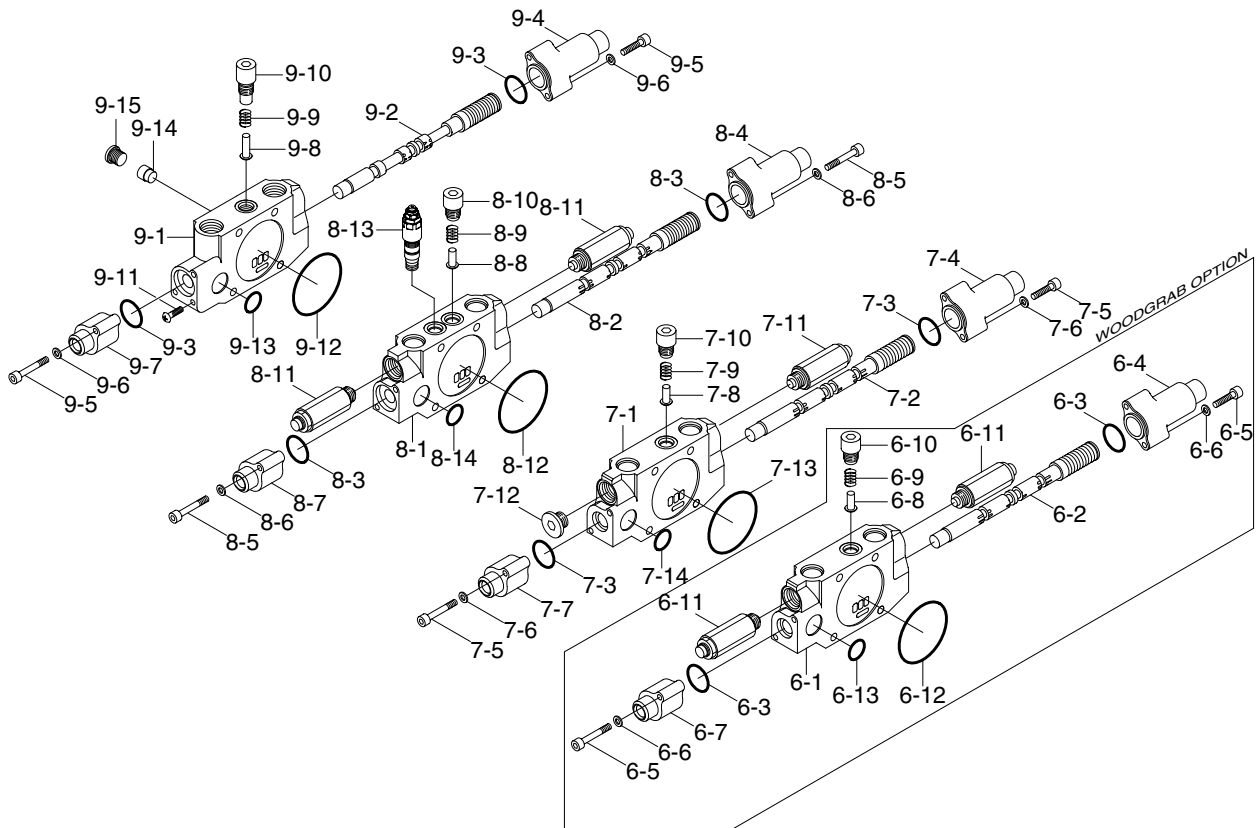

555W92MC03

6	Woodgrab block	7-6	Plain washer	8-11	Overload relief valve
6-1	Block	7-7	Pilot cap (B1)	8-12	O-ring
6-2	Woodgrab spool assy	7-8	Check poppet	8-13	Check valve
6-3	O-ring	7-9	Check spring	8-14	O-ring
6-4	Pilot cap (A)	7-10	Plug	9	Travel block
6-5	Wrench bolt	7-11	Overload relief valve	9-1	Block
6-6	Plain washer	7-12	Plug	9-2	Travel spool assy
6-7	Pilot cap (B1)	7-13	O-ring	9-3	O-ring
6-8	Check poppet	7-14	O-ring	9-4	Pilot cap (A)
6-9	Check spring	8	Arm 1 block	9-5	Wrench bolt
6-10	Plug	8-1	Block	9-6	Plain washer
6-11	Overload relief valve	8-2	Arm 1 spool assy	9-7	Pilot cap (B1)
6-12	O-ring	8-3	O-ring	9-8	Check poppet
6-13	O-ring	8-4	Pilot cap (A)	9-9	Check spring
7	Boom 2 block	8-5	Wrench bolt	9-10	Plug
7-1	Block	8-6	Plain washer	9-11	Plug
7-2	Boom 2 spool assy	8-7	Pilot cap (B1)	9-12	O-ring
7-3	O-ring	8-8	Check poppet	9-13	O-ring
7-4	Pilot cap (A1)	8-9	Check spring	9-14	Poppet
7-5	Wrench bolt	8-10	Plug	9-15	Spring seat

STRUCTURE (3/4)

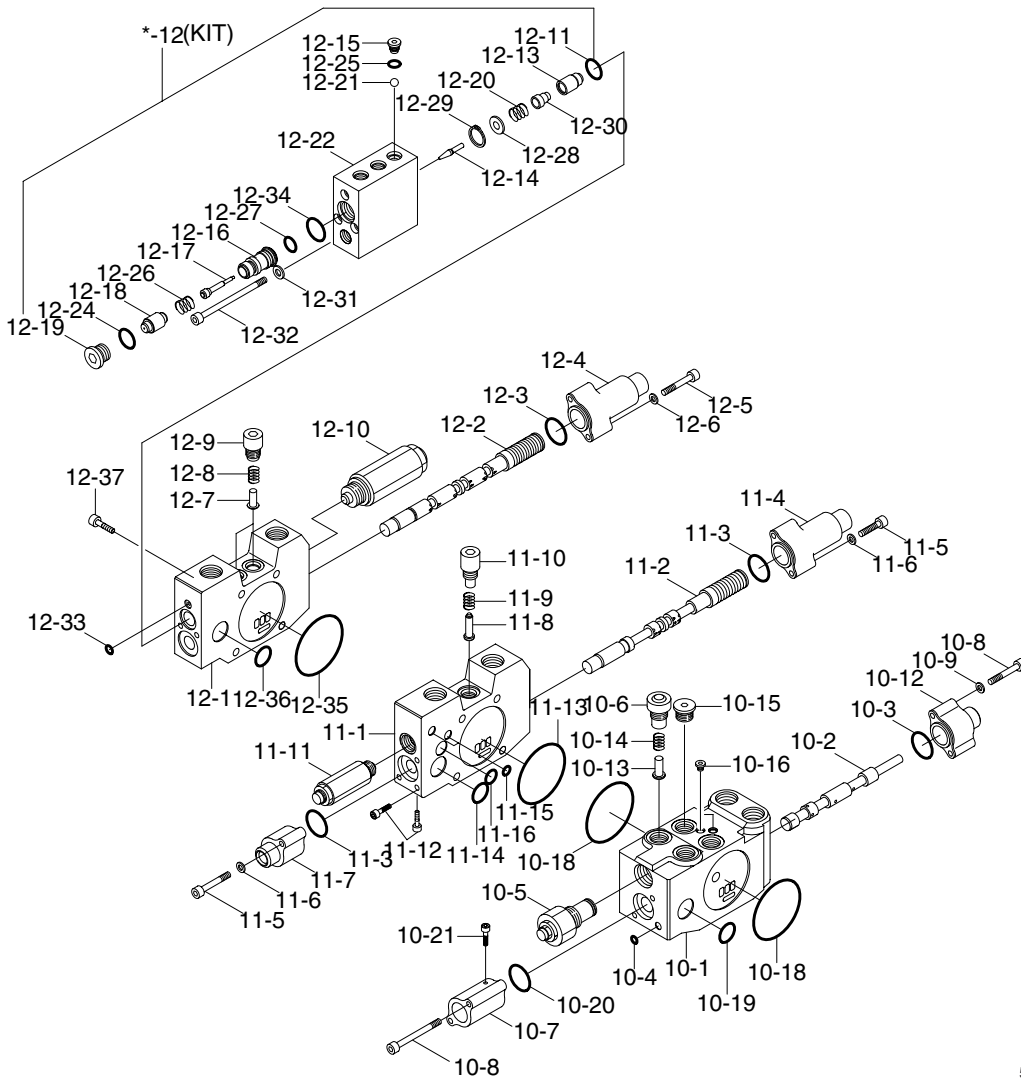

555W92MC04

10	Inlet block	10-21	Plug	12	Boom 1 block	12-19	Plug
10-1	Block	11	Travel block	12-1	Block	12-20	Spring
10-2	Travel straight spool assy	11-1	Block	12-2	Boom 1 spool assy	12-21	Steel ball
10-3	O-ring	11-2	Travel spool assy	12-3	O-ring	12-22	Pilot cover
10-4	O-ring	11-3	O-ring	12-4	Pilot cap (A)	12-24	O-ring
10-5	Main relief valve	11-4	Pilot cap (A)	12-5	Wrench bolt	12-25	O-ring
10-6	Plug 3	11-5	Wrench bolt	12-6	Plain washer	12-26	Spring
10-7	Pilot cap (B3)	11-6	Plain washer	12-7	Check poppet	12-27	O-ring
10-8	Wrench bolt	11-7	Pilot cap (B1)	12-8	Check spring	12-28	Spring seat
10-9	Plain washer	11-8	Check poppet	12-9	Plug	12-29	Snap ring
10-12	Pilot cap (B2)	11-9	Check spring	12-10	Overload relief valve	12-30	Resistor
10-13	Check poppet	11-10	Plug	12-11	O-ring	12-31	Plain washer
10-14	Check spring	11-11	Overload relief valve	12-12	Holding poppet	12-32	Wrench bolt
10-15	Plug	11-12	Set screw	12-13	Pilot poppet	12-33	O-ring
10-16	Plug	11-13	O-ring	12-14	Pilot poppet	12-34	O-ring
10-18	O-ring	11-14	O-ring	12-15	Plug	12-35	O-ring
10-19	O-ring	11-15	O-ring	12-16	Piston guide	12-36	O-ring
10-20	O-ring	11-16	O-ring	12-17	Piston	12-37	Socket bolt
				12-18	Pilot piston		

STRUCTURE (4/4)

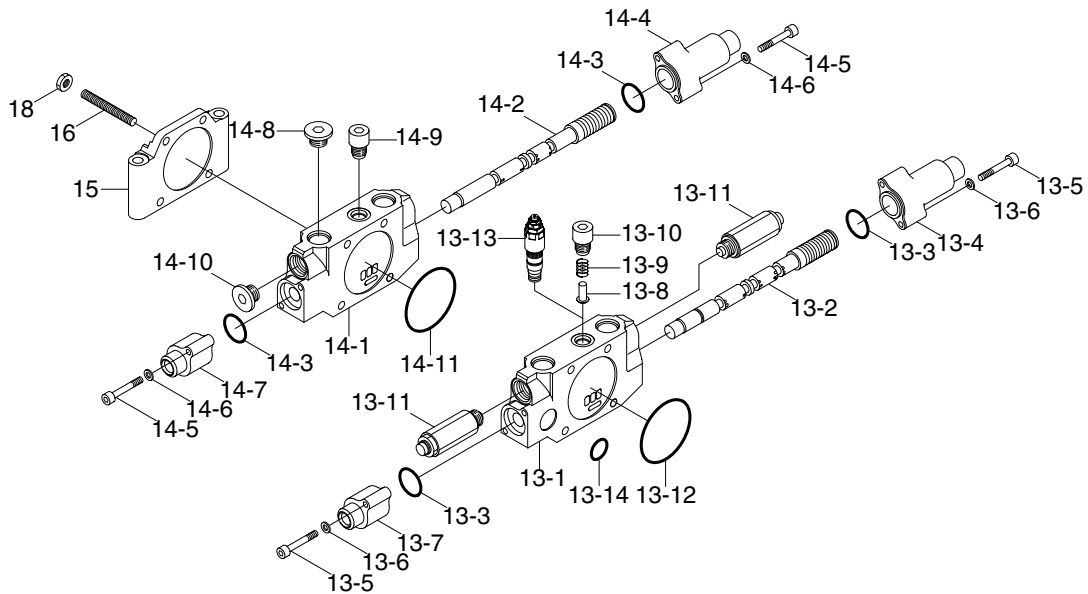

555W92MC05

13	Bucket block	13-10	Plug	14-5	Wrench bolt
13-1	Block	13-11	Relief valve	14-6	Plain washer
13-2	Bucket spool assy	13-12	O-ring	14-7	Pilot cap (B1)
13-3	O-ring	13-13	Check valve	14-8	Plug
13-4	Pilot cap (A)	13-14	O-ring	14-9	Plug
13-5	Wrench bolt	14	Arm 2 block	14-10	Plug
13-6	Plain washer	14-1	Block	14-11	O-ring
13-7	Pilot cap (B1)	14-2	Arm 2 assy	15	Cover
13-8	Check poppet	14-3	O-ring	16	Tie bolt
13-9	Check spring	14-4	Pilot cap (A)	18	Nut

3. DISASSEMBLY AND ASSEMBLY

1) GENERAL PRECAUTIONS

- (1) All hydraulic components are manufactured to a high precision. Consequently, before disassembling and assembling them, it is essential to select an especially clean place.
- (2) In handling a control valve, pay full attention to prevent dust, sand, etc. from entering into it.
- (3) When a control valve is to be removed from the machine, apply caps and masking seals to all ports. Before disassembling the valve, recheck that these caps and masking seals are fitted completely, and then clean the outside of the assembly. Use a proper bench for working. Spread paper or a rubber mat on the bench, and disassemble the valve on it.
- (4) Support the body section carefully when carrying or transferring the control valve. Do not lift by the exposed spool, end cover section etc.
- (5) After disassembling and assembling of the component it is desired to carry out various tests (for the relief characteristics, leakage, flow resistance, etc.), but hydraulic test equipment is necessary for these tests. Therefore, even when its disassembling can be carried out technically, do not disassemble such components that cannot be tested, adjusted, and so on. Additionally one should always prepare clean cleaning oil, hydraulic oil, grease, etc. beforehand.

2) TOOLS

Before disassembling the control valve, prepare the following tools beforehand.

Name of tool	Quantity	Size (mm)
Vice mounted on bench (soft jaws)	1 unit	
Hexagon wrench	Each 1 piece	5, 6, 10, 12 and 14
Socket wrench	Each 1 piece	5 and 6
Spanner	Each 1 piece	13, 21 and 30
Rod	1 piece	Less than 10 × 250

3) DISASSEMBLY

(1) Disassembly of spools

- ① Loosen hexagon socket head bolts (5) with washer (6).
(Hexagon wrench : 5 mm)
- ② Remove the pilot cover (3).
 - ※ Pay attention not to lose the O-ring (7) under the pilot cover.
- ③ Remove the spool assembly (2) from the body by hand slightly.
 - ※ When extracting each spool from its body, pay attention not to damage the body.
 - ※ When extracting each spool assembly, it must be extracted from spring side only.
 - ※ When any abnormal parts are found, replace it with completely new spool assembly.
 - ※ When disassembled, tag the components for identification so that they can be reassembled correctly.

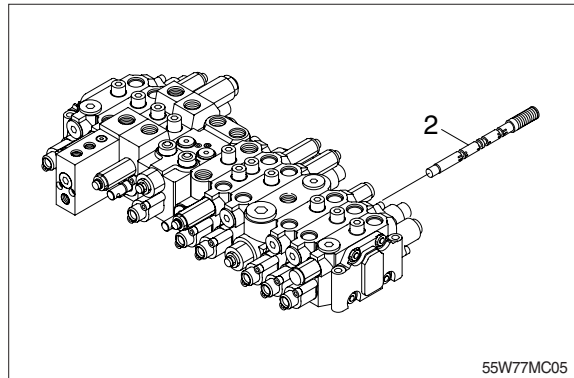
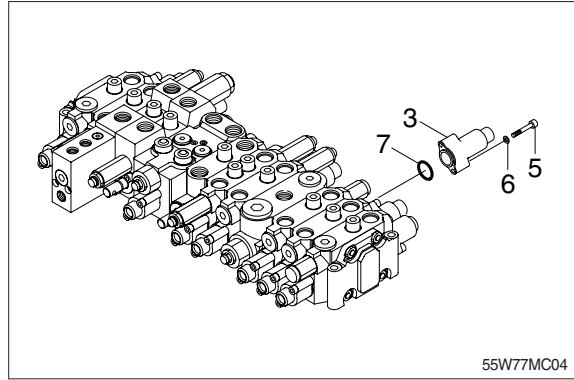

(2) Disassembly of holding valve (boom 1)

- ① Loosen hexagon socket head bolts (7).
(hexagon wrench : 5 mm)
- ② Remove the holding valve.
 - ※ Pay attention not to lose the O-ring and the poppet under the pilot cover.
 - ※ Pay attention not to damage the "piston A" under pilot cover.
 - ※ When any abnormal parts are found, replace it with completely new holding valve assembly.
 - ※ When disassembled, tag the components for identification so that they can be reassembled correctly.

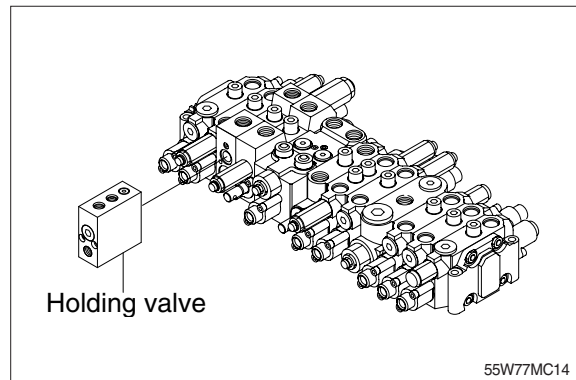
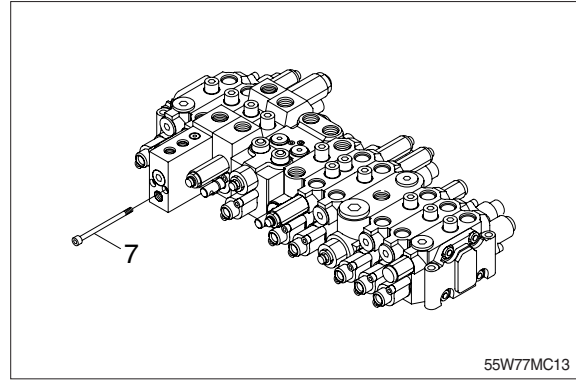

(3) Disassembly of the load check valve and the negative relief valve

- ① The load check valve
 - a. Fix the body to suitable work bench.
 - ※ Pay attention not to damage the body.
 - b. Loosen the plug (10)
(hexagon wrench : 10 mm).
 - c. Remove the spring (9) and the load check valve (8) with pincers or magnet.

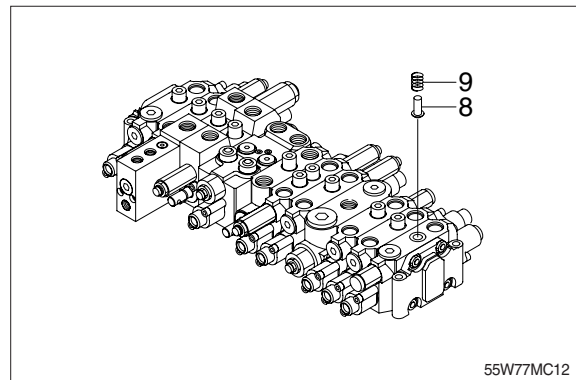
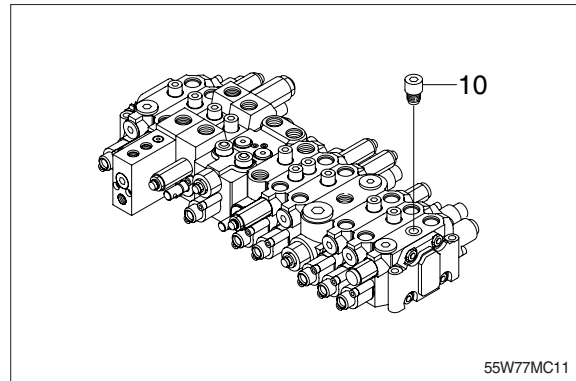

(4) Disassembly of the main and overload relief valve

- ① Fix the body to suitable work bench.
 - ② Remove the main relief valve (5).
(spanner : 30 mm)
 - ③ Remove the overload relief valve (12).
(spanner : 22 mm)
- ※ When disassembled, tag the relief valve for identification so that they can be reassembled correctly.
 - ※ Pay attention not to damage seat face.
 - ※ When any abnormal parts are found, replace it with completely new relief valve assembly.

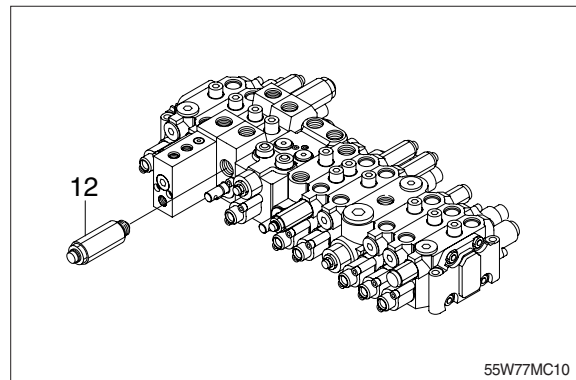
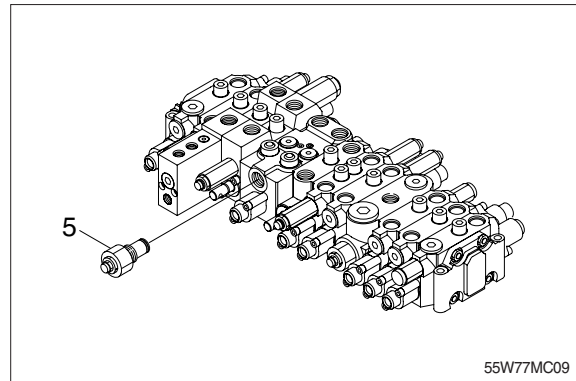

(5) Disassembly of the block assembly

- ① Fix the body to suitable work bench.
- ② Remove the nut (20).
(spanner : 13 mm)
 - ※ The work block is assembled by two sets of tie-bolts.
- ③ Remove the end cover (1) and the work blocks.
 - ※ Do not removed the tie bolt.
 - ※ Pay attention not to lose the O-ring (16).

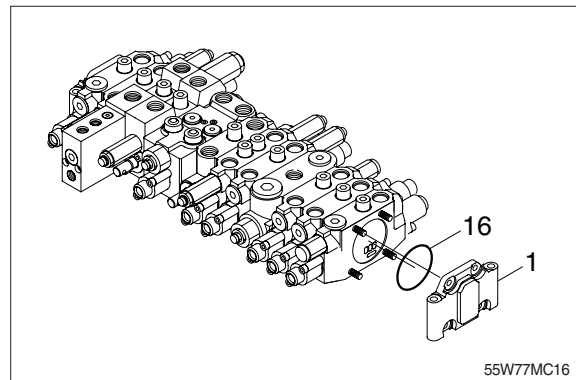
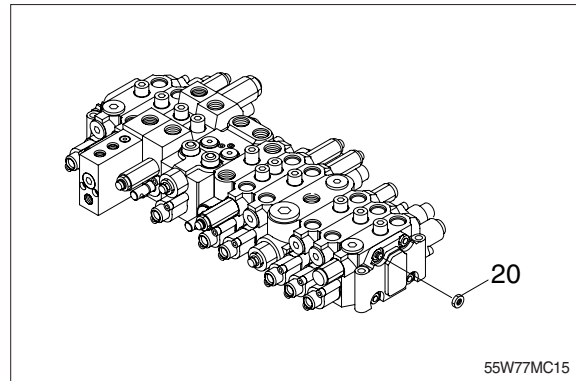

(6) Inspection after disassembly

Clean all disassembled parts with clean mineral oil fully, and dry them with compressed air. Then, place them on clean papers or cloths for inspection.

① Control valve

- a. Check whole surfaces of all parts for burrs, scratches, notches and other defects.
- b. Confirm that seal groove faces of body and block are smooth and free of dust, dent, rust etc.
- c. Correct dents and damages and check seat faces within the body, if any, by lapping.
※ Pay careful attention not to leave any lapping agent within the body.
- d. Confirm that all sliding and fitting parts can be moved manually and that all grooves and paths are free foreign matter.
- e. If any spring is broken or deformed, replace it with new one.
- f. When a relief valve does not function properly, repair it, following it's the prescribed disassembly and assembly procedures.
- g. Replace all seals and O-rings with new ones.

② Relief valve

- a. Confirm that all seat faces at ends of all poppets and seats are free of defects and show uniform and consistent contact faces.
- b. Confirm manually that main poppet and seat can slide lightly and smoothly.
- c. Confirm that outside face of main poppet and inside face of seat are free from scratches and so on.
- d. Confirm that springs are free from breakage, deformation, and wear.
- e. Confirm that orifices of main poppet and seat section are not clogged with foreign matter.
- f. Replace all O-rings with new ones.
- g. When any light damage is found in above inspections, correct it by lapping.
- h. When any abnormal part is found, replace it with a completely new relief valve assembly.

4) ASSEMBLY

(1) General precaution

- ① In this assembly section, explanation only is shown.
For further understanding, please refer to the figures shown in the previous structure & disassembly section.
- ② Pay close attention to keeping all seals free from handling damage and inspect carefully for damage before using them.
- ③ Apply clean grease or hydraulic oil to the seal so as to ensure it is fully lubricated before assembly.
- ④ Do not stretch seals so much as to deform them permanently.
- ⑤ In fitting O-rings, pay close attention not to roll them into their final position in addition, a twisted O-ring cannot easily untwist itself naturally and could thereby cause inadequate sealing and thereby both internal and external oil leakage.
- ⑥ Tighten fitting bolts for all sections with a torque wrench adjusted to the respective tightening torque.
- ⑦ Do not reuse removed O-rings and seals.

(2) Load check valve

- ① Assemble the load check valve (8) and spring (9).
- ② Put O-rings on to plug (10).
- ③ Tighten plug to the specified torque.
 - Hexagon wrench : 8 mm
 - Tightening torque : 3.7 kgf · m
(26.7 lbf · ft)

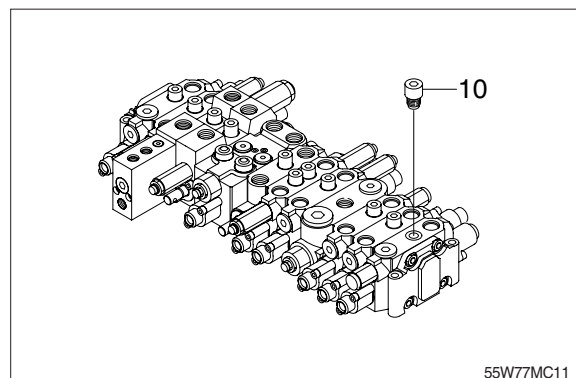
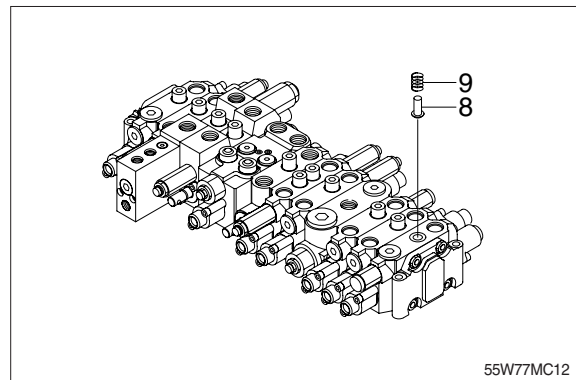

(3) Main relief, port relief valves

- ① Install the main relief valve (5).
 - Spanner : 30 mm
 - Tightening torque : 6 kgf · m (43.4 lbf · ft)
- ② Install the over load relief valve (12).

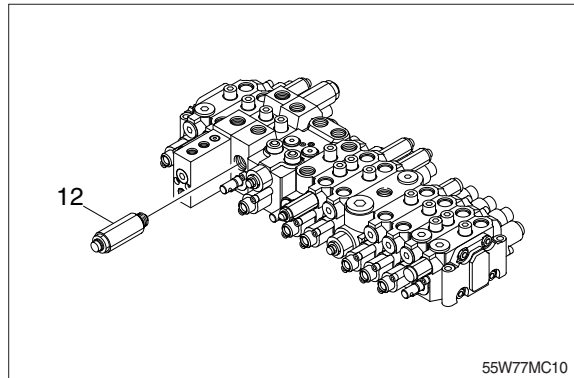
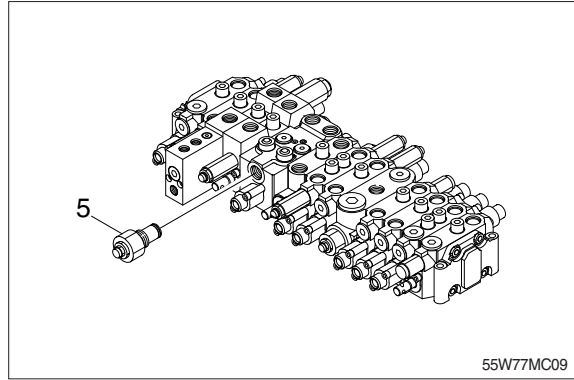

(4) Main spools

- ① Carefully insert the previously assembled spool assemblies into their respective bores within of body.
- ※ Fit spool assemblies into body carefully and slowly. Do not under any circumstances push them forcibly in.

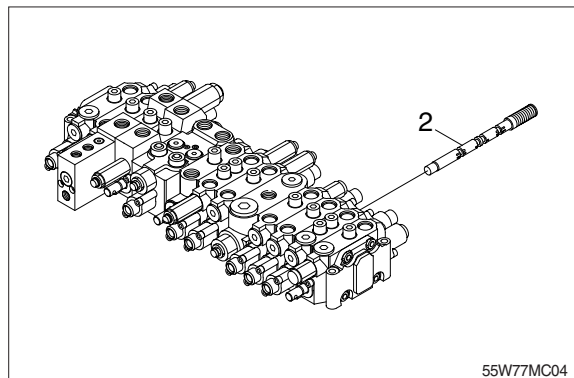

(5) Covers

- ① Fit spool covers (3) tighten the hexagonal socket head bolts (5) to the specified torque.
- Hexagon wrench : 5 mm
 - Tightening torque : 1~1.1 kgf · m
(7.2~7.9 lbf · ft)
- ※ Confirm that O-rings (7) have been fitted.

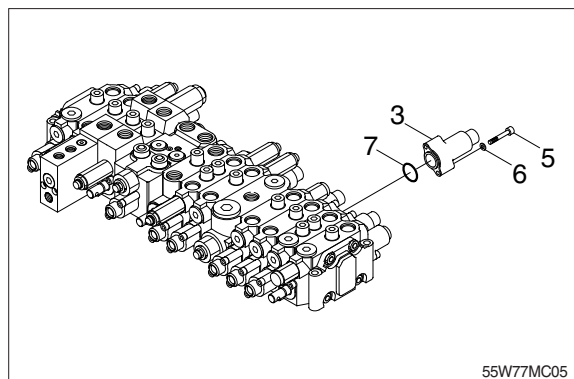

(6) Holding valve

① Fit the holding valve to the body and tighten hexagon socket head bolt (7) to specified torque.

- Hexagon wrench : 5 mm
- Tightening torque : 1.1 kgf · m (7.9 lbf · ft)

