

GROUP 2 MAJOR COMPONENT

1. MAIN PUMP

Before inspection, wash the parts well and dry them completely.

Inspect the principal parts with care and replace them with new parts when any abnormal wear exceeding the allowable limit or damage considered harmful is found.

Replace the seal also when any remarkable deformation and damage are found.

1) PISTON ASSEMBLY AND CYLINDER BLOCK

- (1) Check the appearance visually.

No damage, scouring, abnormal wear (particularly, in the slide portion) should be found.

- (2) Check the clearance between the piston outside dia and cylinder block inside dia.

$$D-d \leq 0.050 \text{ mm}$$

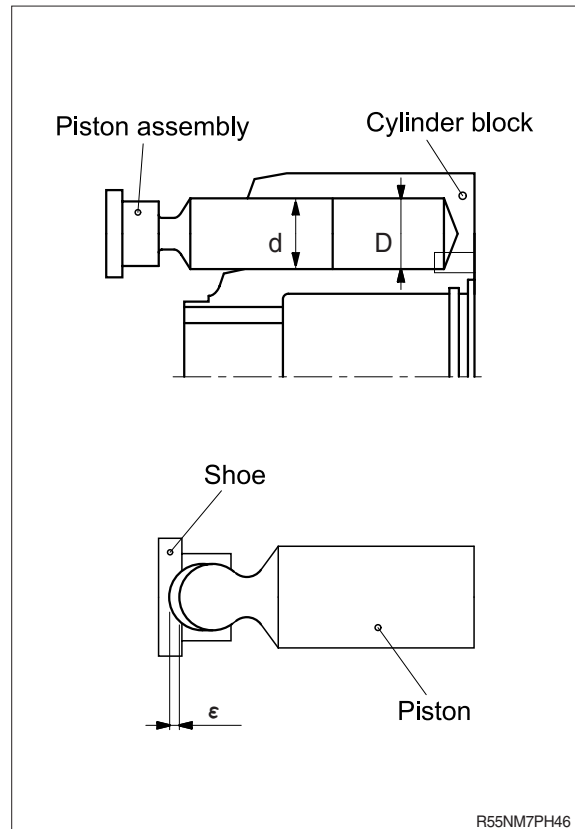

2) PISTON SHOE AND PISTON

- (1) Check the axial play of the piston and piston shoe.

$$\epsilon \leq 0.2\text{mm}$$

3) SHAFT

- (1) Check the wear amount of the oil seal mounting section.

$$\text{Wear amount} \leq 0.025 \text{ mm}$$

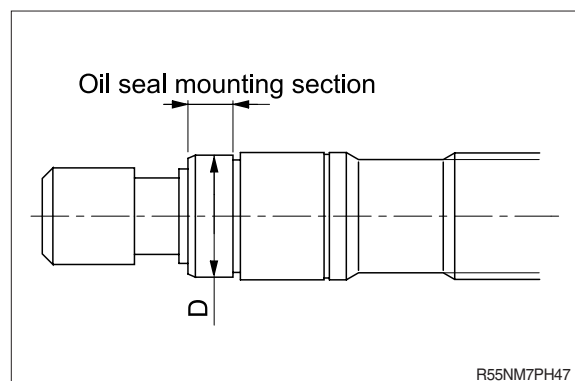

4) CONTROL PLATE

- (1) Check the slide surface for any damage.
When the damage is large, replace the plate with new one.

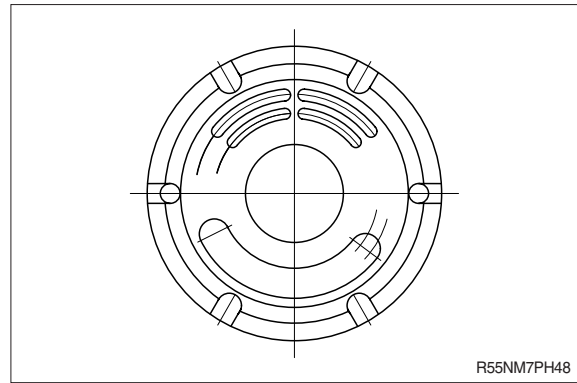

5) GUIDE AND RETAINER

- (1) Check for scouring or stepped wear.
If this can not be corrected, replace the guide and retainer with new full-set.
- (2) Fine scouring or damage can be corrected with lapping.
Carry out thorough washing after lapping.

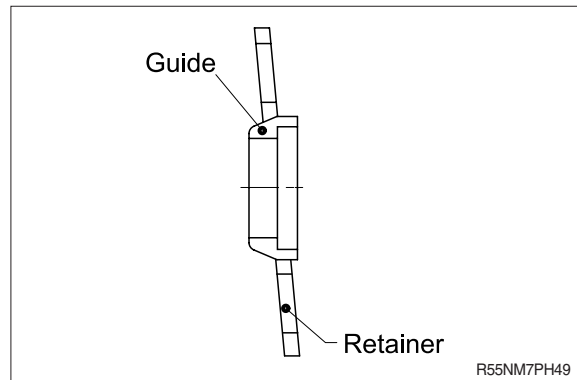

2. MAIN CONTROL VALVE

Part name	Inspection item	Criteria & measure
Block	<ul style="list-style-type: none"> Existence of scratch, rusting or corrosion. 	<ul style="list-style-type: none"> In case of damage in following section, replace part. <ul style="list-style-type: none"> Sliding sections of casing fore and spool, especially land sections applied with holded pressure. Seal pocket section where spool is inserted. Seal section of port where O-ring contacts. Seal section of each relief valve for main, travel, and port. Other damages that may damage normal functions.
Spool	<ul style="list-style-type: none"> Existence of scratch, gnawing, rusting or corrosion. O-ring seal sections at both ends. Insert spool in casing hole, rotate and reciprocate it. 	<ul style="list-style-type: none"> Replacement when its outside sliding section has scratch (Especially on seals-contacting section). Replacement when its sliding section has scratch. Correction or replacement when O-ring is damaged or when spool does not move smoothly.
Poppet	<ul style="list-style-type: none"> Damage of poppet or spring Insert poppet into casing and function it. 	<ul style="list-style-type: none"> Correction or replacement when sealing is incomplete. Normal when it can function lightly without being caught.
Around spring	<ul style="list-style-type: none"> Rusting, corrosion, deformation or breaking of spring, spring seat, plug or cover. 	<ul style="list-style-type: none"> Replacement for significant damage.
Around seal for spool	<ul style="list-style-type: none"> External oil leakage. Rusting, corrosion or deformation of seal plate. 	<ul style="list-style-type: none"> Correction or replacement. Correction or replacement.
Main relief valve & port relief valve	<ul style="list-style-type: none"> External rusting or damage. Contacting face of valve seat. Contacting face of poppet. Abnormal spring. O-rings, back up rings and seals. 	<ul style="list-style-type: none"> Replacement. Replacement when damaged. Replacement when damaged. Replacement. 100% replacement in general.

3. SWING DEVICE

1) WEARING PARTS

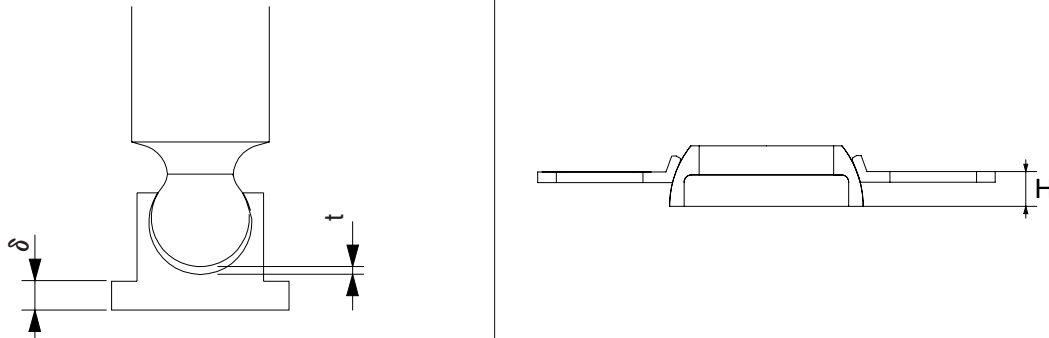
Inspection item	Standard dimension	Recommended replacement value	Counter measures
Clearance between piston and cylinder block bore	0.020	0.045	Replace piston or cylinder block
Play between piston and shoe caulking section (t)	0	0.3	Replace assembly of piston and shoe
Thickness of shoe (δ)	4	3.8	Replace assembly of piston and shoe
Combined height of set plate and guide (H)	17.4	17	Replace set of set plate and guide
Thickness of friction plate	3.6	3.2	Replace
			

2) SLIDING PARTS

Part name	Standard roughness	Remark
Shoe	0.8S	
Shoe plate	0.8S	
Cylinder	0.8S	
Valve plate	0.8S	

4. TRAVEL MOTOR

- 1) Free of corrosion, erosion or fretting; no damage to splines or keyways.

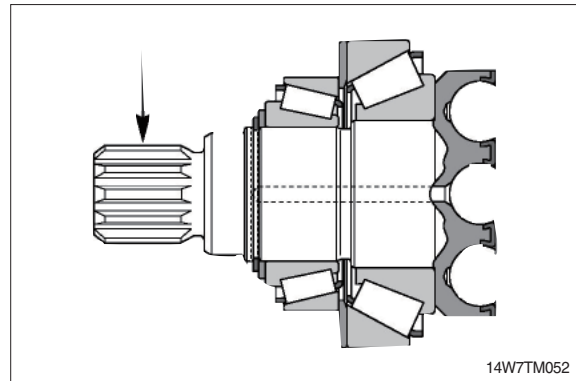

2) Pistons

- No scoring and no pittings.

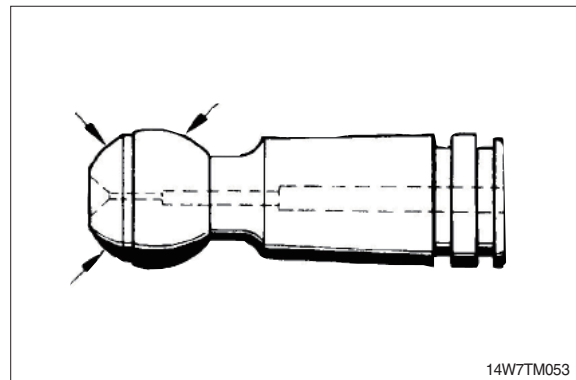

3) Center pin

- No scoring and no pittings.

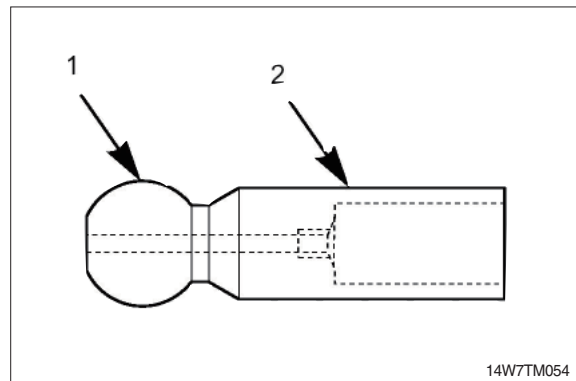

4) Retaining plate

- No scoring and no evidence of wear.

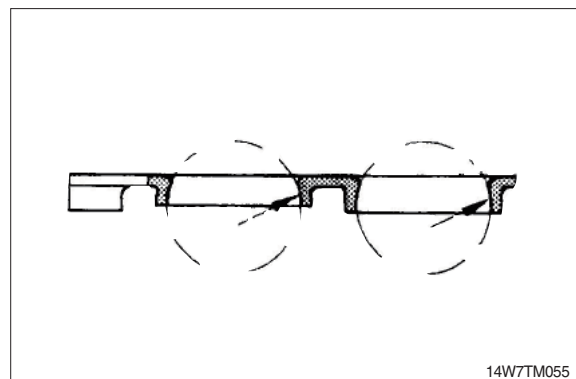

5) Cylinder block/control lens

- ① Bores free of scoring, no evidence of wear.
- ② Faces smooth and even, free of cracks and scoring.

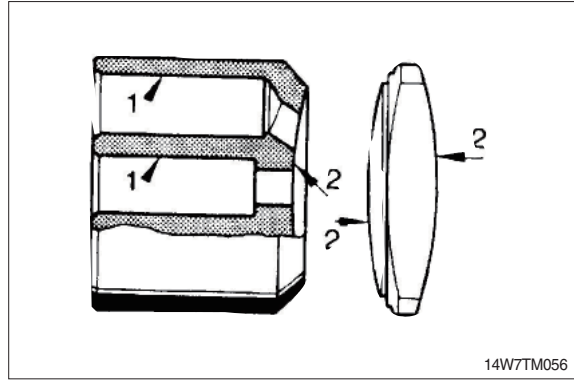

6) Control housing

Sliding surface and side guides free of scoring and no wear.

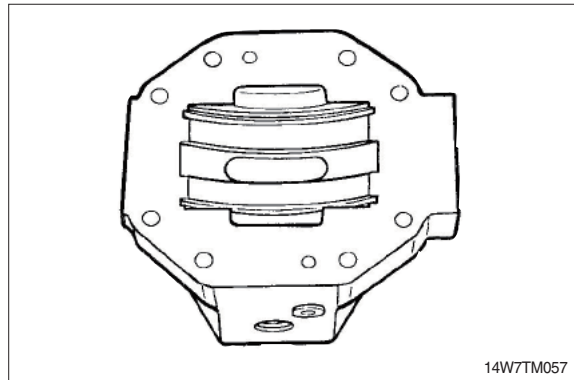

7) Visual check

Bearing areas free of scoring and no evidence of wear.

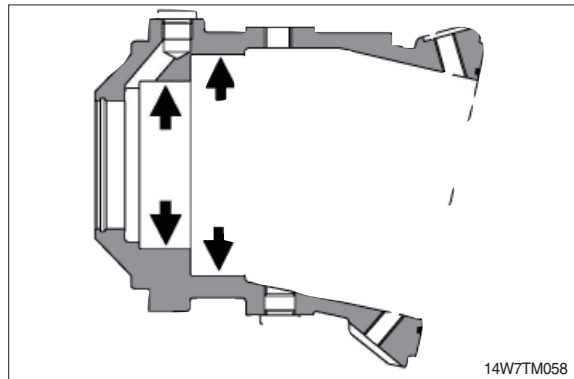

5. RCV LEVER

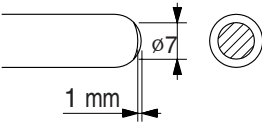
Maintenance check item	Criteria	Remark
Leakage	The valve is to be replaced when the leakage becomes more than 1000 cc/m at neutral handle position, or more than 2000 cc/m during operation.	Conditions : Primary pressure : 30 kgf/cm ² Oil viscosity : 23 cSt
Spool	This is to be replaced when the sliding surface has worn more than 10 μ m, compared with the non-sliding surface.	The leakage at the left condition is estimated to be nearly equal to the above leakage.
Push rod	 <p>This is to be replaced when the top end has worn more than 1mm.</p>	
Play at operating section	The pin, shaft, and joint of the operating section are to be replaced when their plays become more than 2 mm due to wears or so on.	When a play is due to looseness of a tightened section, adjust it.
Operation stability	When abnormal noises, hunting, primary pressure drop, etc. are generated during operation, and these cannot be remedied, referring to section 6 troubleshooting, replace the related parts.	

Notes 1. It is desirable to replace seal materials, such as O-rings, every disassembling. However, they may be reused, after being confirmed to be free of damage.

6. ACCELERATOR PEDAL

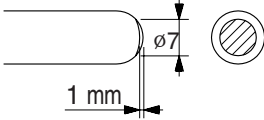
Maintenance check item	Criteria	Remark
Leakage	The valve is to be replaced when the leakage effect to the system. For example, the primary pressure drop.	Conditions : Primary pressure : 30 kgf/cm ² Oil viscosity : 23 cSt
Spool	This is to be replaced when the sliding surface has worn more than 10 μ m, compared with the non-sliding surface.	The leakage at the left condition is estimated to be nearly equal to the above leakage.
Push rod	 <p>This is to be replaced when the top end has worn more than 1mm.</p>	
Play at operating section	The pin, shaft, and joint of the operating section are to be replaced when their plays become more than 2mm due to wears or so on.	When a play is due to looseness of a tightened section, adjust it.
Operation stability	When abnormal noises, hunting, primary pressure drop, etc. are generated during operation, and these cannot be remedied, referring to section 6 troubleshooting, replace the related parts.	

Notes 1. It is desirable to replace seal materials, such as O-rings, every disassembling. However, they may be reused, after being confirmed to be free of damage.

7. TURNING JOINT

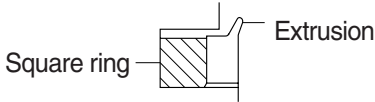
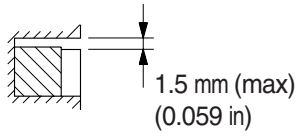
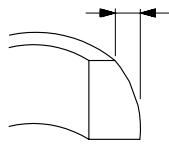
Part name		Maintenance standards	Remedy
Body, Stem	Sliding surface with sealing sections	Plating worn or peeled due to seizure or contamination	Replace
	Sliding surface between body and stem other than sealing section	· Worn abnormality or damaged more than 0.1 mm (0.0039 in) in depth due to seizure contamination	Replace
		· Damaged more than 0.1 mm (0.0039 in) in depth	Smooth with oilstone
	Sliding surface with thrust plate	· Worn more than 0.5 mm (0.02 in) or abnormality	Replace
		· Worn less than 0.5 mm (0.02 in)	Smooth
		· Damage due to seizure or contamination remediable within wear limit (0.5 mm) (0.02 in)	Smooth
Cover	Sliding surface with thrust plate	· Worn more than 0.5 mm (0.02 in) or abnormality	Replace
		· Worn less than 0.5 mm (0.02 in)	Smooth
		· Damage due to seizure or contamination remediable within wear limit (0.5 mm) (0.02 in)	Replace
Seal set	-	<ul style="list-style-type: none"> · Extruded excessively from seal groove square ring 	Replace
	-	<ul style="list-style-type: none"> · Slipper ring 1.5 mm (0.059 in) narrower than seal groove, or narrower than back ring 	Replace
	-	<ul style="list-style-type: none"> · Worn more than 0.5 mm (0.02 in) ~ 1.5 mm (MAX) (0.059 in) 	Replace

8. CYLINDER

Part name	Inspecting section	Inspection item	Remedy
Piston rod	• Neck of rod pin	• Presence of crack	• Replace
	• Weld on rod hub	• Presence of crack	• Replace
	• Stepped part to which piston is attached	• Presence of crack	• Replace
	• Threads	• Presence of crack	• Recondition or replace
	• Plated surface	• Plating is not worn off to base metal Rust is not present on plating Scratches are not present	• Replace or replate • Replace or replate • Recondition, replate or replace
	• Rod	• Wear of O.D.	• Recondition, replate or replace
Cylinder tube	• Bushing at mounting part	• Wear of I.D.	• Replace
	• Weld on bottom	• Presence of crack	• Replace
	• Weld on head	• Presence of crack	• Replace
	• Weld on hub	• Presence of crack	• Replace
	• Tube interior	• Presence of faults	• Replace if oil leak is seen
	• Bushing at mounting part	• Wear on inner surface	• Replace
Gland	• Bushing	• Flaw on inner surface	• Replace if flaw is deeper than coating

9. WORK EQUIPMENT

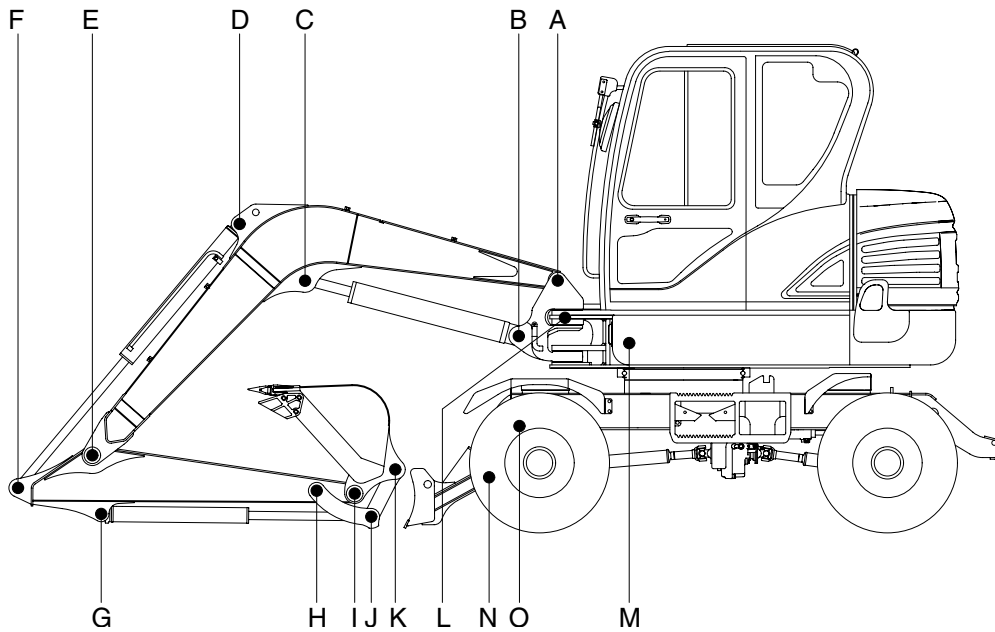

555W96MS30

Unit : mm

Mark	Measuring point (pin and bushing)	Normal value	Pin		Bushing		Remedy & Remark
			Recomm. service limit	Limit of use	Recomm. service limit	Limit of use	
A	Boom Rear	50	49	48.5	50.5	51	Replace
B	Boom Cylinder Head	60	59	58.5	60.5	61	"
C	Boom Cylinder Rod	60	59	58.5	60.5	61	"
D	Arm Cylinder Head	50	49	48.5	50.5	51	"
E	Boom Front	50	49	48.5	50.5	51	"
F	Arm Cylinder Rod	50	49	48.5	50.5	51	"
G	Bucket Cylinder Head	45	44	43.5	45.5	46	"
H	Arm Link	45	44	43.5	45.5	46	"
I	Bucket and Arm Link	45	44	43.5	45.5	46	"
J	Bucket Cylinder Rod	45	44	43.5	45.5	46	"
K	Bucket Link	45	44	43.5	45.5	46	"
L	Boom swing post	110	109	108.5	110.5	111	"
M	Boom swing cylinder	50	49	48.5	50.5	51	"
N	Blade cylinder	55	54	53.5	55.5	56	"
O	Blade and frame link	35	34	33.5	35.5	36	"