

# SECTION 3 HYDRAULIC SYSTEM

## GROUP 1 HYDRAULIC CIRCUIT

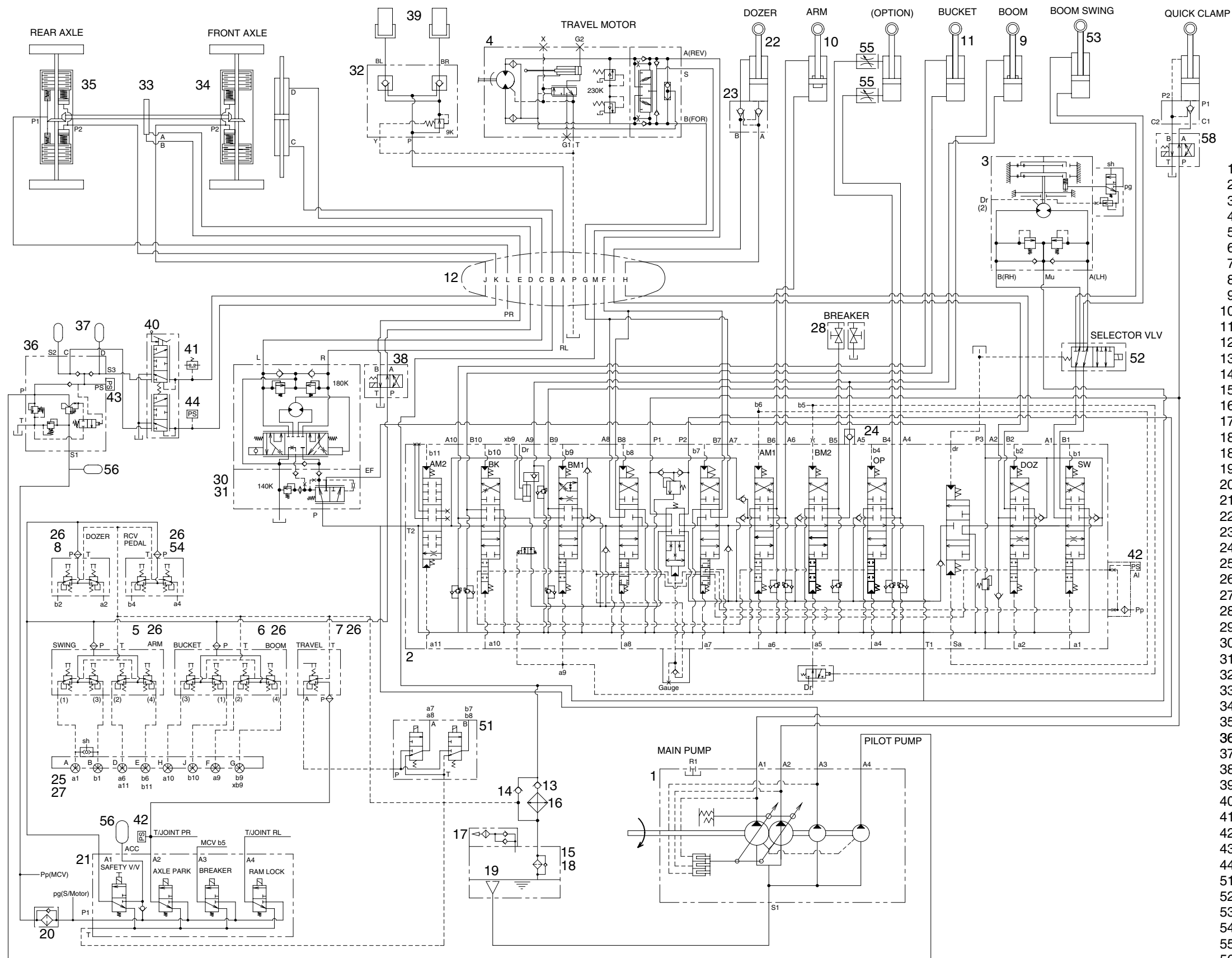

- 1 Main pump
- 2 Main control valve
- 3 Swing motor
- 4 Travel motor
- 5 RCV lever(LH)
- 6 RCV lever(RH)
- 7 RCV pedal
- 8 RCV dozer
- 9 Boom cylinder
- 10 Arm cylinder
- 11 Bucket cylinder
- 12 Turning joint
- 13 Check valve
- 14 Check valve
- 15 Hydraulic tank
- 16 Oil cooler
- 17 Air breather
- 18 Bypass valve
- 18 Return element
- 19 Suction strainer
- 20 Pilot filter
- 21 Solenoid valve
- 22 Dozer cylinder
- 23 Check valve
- 24 Check valve
- 25 Terminal
- 26 Last guard filter
- 27 Shuttle valve
- 28 Stop valve
- 29 Selector valve
- 30 Priority valve
- 31 Steering valve
- 32 Locking valve
- 33 Gear box
- 34 Front axle
- 35 Rear axle
- 36 Cut off valve
- 37 Accumulator
- 38 Solenoid valve
- 39 Oscillating cylinder
- 40 Brake valve
- 41 Pressure switch
- 42 Pressure sensor
- 43 Pressure sensor
- 44 Pressure sensor
- 51 Solenoid valve
- 52 Selector valve
- 53 Boom swing cylinder
- 54 2 Way pedal
- 55 Variable orifice
- 56 Accumulator
- 58 Solenoid valve

55W93HC01