

# GROUP 8 GEAR BOX

## 1. STRUCTURE

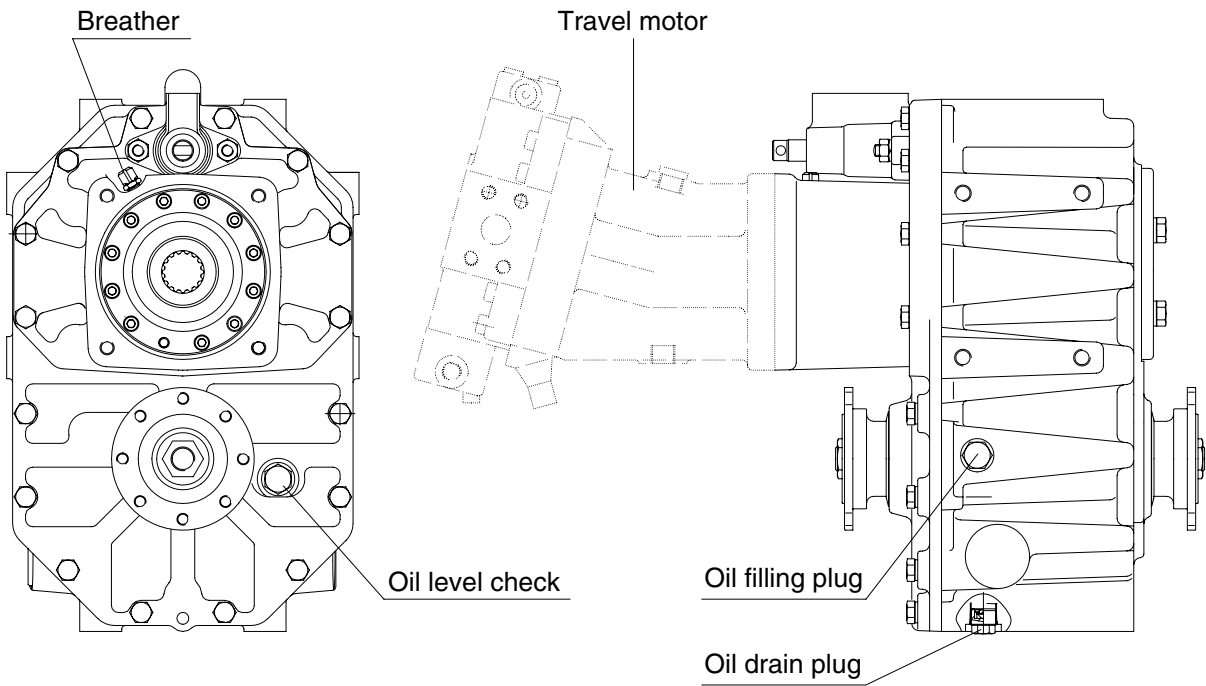
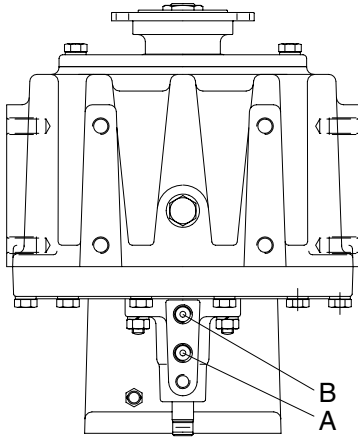

55W72GB01

## 2. GEAR BOX FUNCTION

It explains mechanism, function operation principle and caution in the operation of transfer gear box applied to for this equipment.

### 1) GEAR BOX MECHANISM

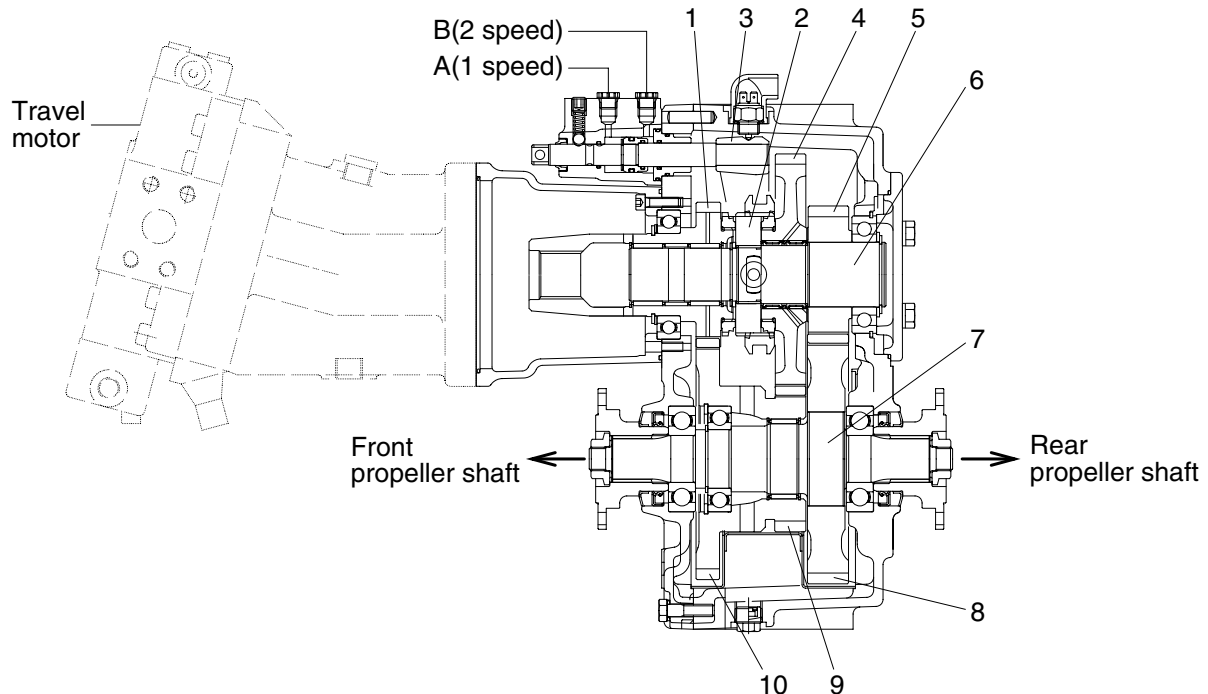

55W72GB02

1	Input shaft gear	5	Input shaft gear	8	Output shaft gear
2	Change selector	6	Input shaft	9	Idle gear
3	Selector shaft	7	Output shaft	10	Idle gear
4	Idle gear				

### 2) FUNCTION

Transfer gear box applied to R55W-7 is a hydraulic system having 1-2 speed gear and its system is dog clutch type.

Once pushing 1 speed button for speed change, exhausted hydraulic power flow from the pump supplied to port "A" by operating 1,2 speed solenoid valve and change selector (2) pushed by selector shift (3) goes in gear with idle gear (4).

The power gear box is moved to input gear shaft (1), idle gear (10), idle gear (9), idle gear (4), change selector (2), input shaft (7) and this procedure lead to 1 speed operation status.

Meanwhile, once pushing 2 speed button in the equipment stop condition, hydraulic power flow from the pump supplied to port "B" and change selector (2) pushed by selector shaft (3) goes in gear with input shaft (1).

The power gear box is moved to input shaft gear (1), change selector (2), input shaft (6), input shaft gear (5), output shaft gear (8), output shaft (7) and this procedure lead to 2 speed operation status.

### 3. TECHNICAL DATA

#### 1) GENERAL DATA

- (1) Max. input power : 33 kW
- (2) Max. input torque : 24.6 kg · m
- (3) Max. input speed : 3114 rpm
- (4) Hydraulic motor : 80 cc/rev
- (5) Gear ration
  - 1st speed : 6,357
  - 2nd speed : 1,961
- (6) Output flange
  - Bolt for propshaft connection : M10 × 1.25
  - Gear box weight : 63 kg (140 lb)

#### 2) GEAR BOX CONTROL

##### (1) Control pressure

- ① At connection P1 and P2 at Low/High speed : 30 kg/cm<sup>2</sup>
- ② Definition of lubricants : SAE 80W-90

##### 3) HOW TO CHANGE THE TRAVEL SPEED

If you want to change the speed, be sure to operate according to the following procedure. Otherwise, unreasonable operation may cause fatal impact and failure to the transfer box (gear box).

- In case of changing the travel speed, be sure to stop the machine completely.
- Keep the machine on the stationary state and stepping the brake pedal to full stroke. Thereafter, select the speed switch to the desired position.

When operating the travel speed switch without stepping brake pedal and stopping the machine completely, the operation of gear box can not be worked actually even though the position of speed switch is left to the desired position.

- When turning the key switch to "OFF" position to stop the machine, be sure to transfer the travel speed switch to the low speed position.

Because the position of solenoid valve for travel is automatically transferred to the low speed position when turning the key switch to "OFF" position.

