

# GROUP 2 MAIN CONTROL VALVE

## 1. OUTLINE

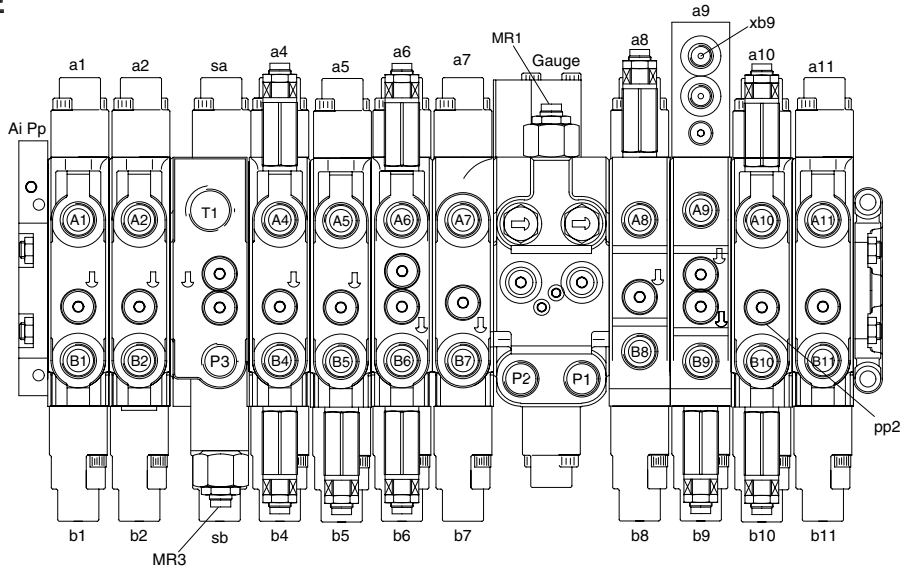

555W92MC01

Mark	Port name	Port size	Tightening torque	Mark	Port name	Port size	Tightening torque
P1	P1 pump port	PF 1/2	6.0~7.0 kgf · m	T1	Tank return port	PF1	10~12 kgf · m
P2	P2 pump port			a1	Swing pilot port (LH)	PF 1/4	2.5~3.0 kgf · m
P3	P3 pump port			b1	Swing pilot port (RH)		
A1	Swing port (LH)			a2	Dozer down pilot port		
B1	Swing port (RH)			b2	Dozer up pilot port		
A2	Dozer down port			a4	Woodgrab open pilot port		
B2	Dozer up port			b4	Woodgrab close pilot port		
A4	Woodgrab close port			a5	Boom 2 pilot port		
B4	Woodgrab open port			b5	Breaker pilot port		
A5	Boom 2 port			a6	Arm out pilot port		
B5	Breaker port			b6	Arm in pilot port		
A6	Arm out port			a7	Travel pilot port (FW)		
B6	Arm in port			b7	Travel pilot port (BW)		
A7	Travel port (FW)			a8	Travel pilot port (FW)		
B7	Travel port (RR)			b8	Travel pilot port (BW)		
A8	Travel port (FW)			a9	Boom up pilot port		
B8	Travel port (RR)			b9	Boom down pilot port		
A9	Boom up port			a10	Bucket out pilot port		
B9	Boom down port			b10	Bucket in pilot port		
A10	Bucket out port			a11	Arm 2 pilot port		
B10	Bucket in port	b11	Arm 2 pilot port				
MR1	Main relief valve	-		PP2	Bucket load check pilot port	PF1/8	
MR2							
B10	Bucket in port	PF 1/2					
B11	Arm 2 port						
T2	Tank return port						

## 2. STRUCTURE (1/4)

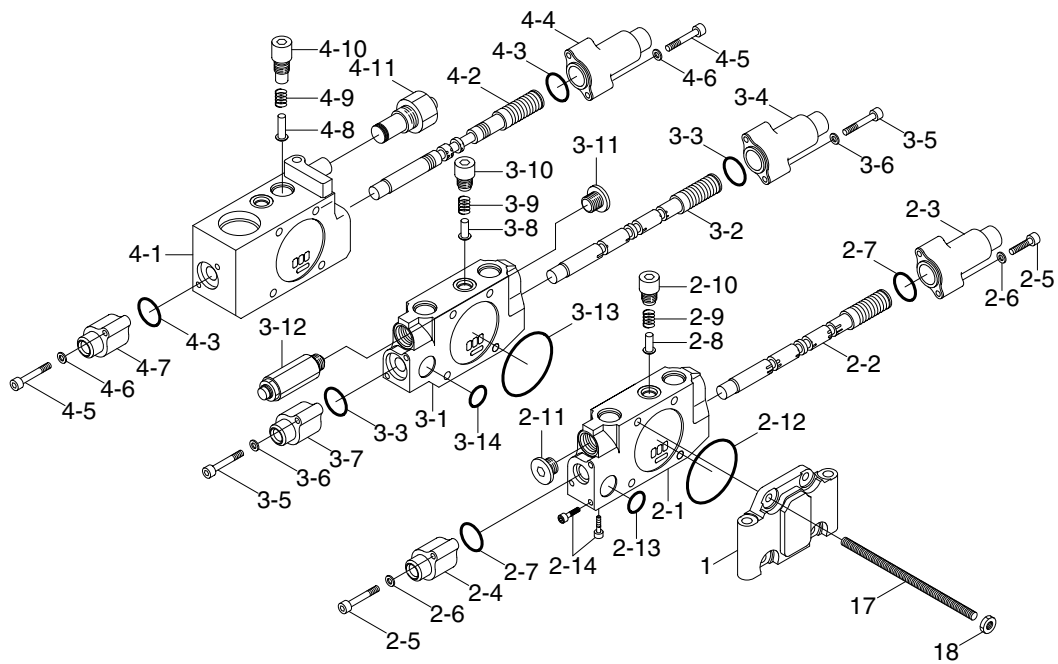

555W92MC02

1	Cover	2-14	Plug	3-14	O-ring
2	Swing block	3	Dozer block	4	Inlet block
2-1	Block	3-1	Block	4-1	Block
2-2	Swing spool assy	3-2	Dozer spool assy	4-2	Inlet spool assy
2-3	Pilot cap (A)	3-3	O-ring	4-3	O-ring
2-4	Pilot cap (B1)	3-4	Pilot cap (A)	4-4	Pilot cap (A)
2-5	Wrench bolt	3-5	Wrench bolt	4-5	Wrench bolt
2-6	Plain washer	3-6	Plain washer	4-6	Plain washer
2-7	O-ring	3-7	Cap	4-7	Pilot cap (B1)
2-8	Check poppet	3-8	Check poppet	4-8	Check poppet
2-9	Check spring	3-9	Check spring	4-9	Check spring
2-10	Plug	3-10	Plug	4-10	Plug
2-11	Plug	3-11	Plug	4-11	Main relief valve
2-12	O-ring	3-12	Check valve	17	Tie bolt
2-13	O-ring	3-13	O-ring	18	Nut

## STRUCTURE (2/4)

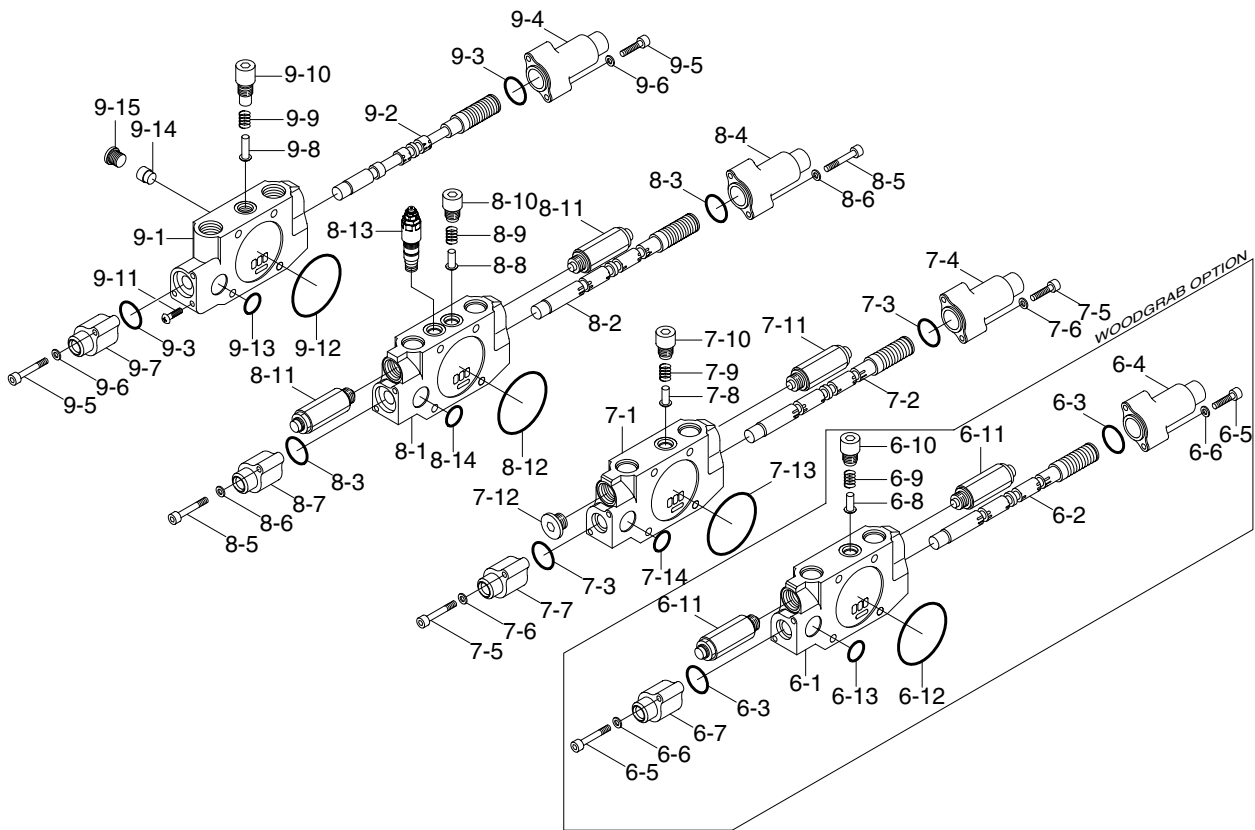

555W92MC03

6	Woodgrab block	7-6	Plain washer	8-11	Overload relief valve
6-1	Block	7-7	Pilot cap (B1)	8-12	O-ring
6-2	Woodgrab spool assy	7-8	Check poppet	8-13	Check valve
6-3	O-ring	7-9	Check spring	8-14	O-ring
6-4	Pilot cap (A)	7-10	Plug	9	Travel block
6-5	Wrench bolt	7-11	Overload relief valve	9-1	Block
6-6	Plain washer	7-12	Plug	9-2	Travel spool assy
6-7	Pilot cap (B1)	7-13	O-ring	9-3	O-ring
6-8	Check poppet	7-14	O-ring	9-4	Pilot cap (A)
6-9	Check spring	8	Arm 1 block	9-5	Wrench bolt
6-10	Plug	8-1	Block	9-6	Plain washer
6-11	Overload relief valve	8-2	Arm 1 spool assy	9-7	Pilot cap (B1)
6-12	O-ring	8-3	O-ring	9-8	Check poppet
6-13	O-ring	8-4	Pilot cap (A)	9-9	Check spring
7	Boom 2 block	8-5	Wrench bolt	9-10	Plug
7-1	Block	8-6	Plain washer	9-11	Plug
7-2	Boom 2 spool assy	8-7	Pilot cap (B1)	9-12	O-ring
7-3	O-ring	8-8	Check poppet	9-13	O-ring
7-4	Pilot cap (A1)	8-9	Check spring	9-14	Poppet
7-5	Wrench bolt	8-10	Plug	9-15	Spring seat

## STRUCTURE (3/4)

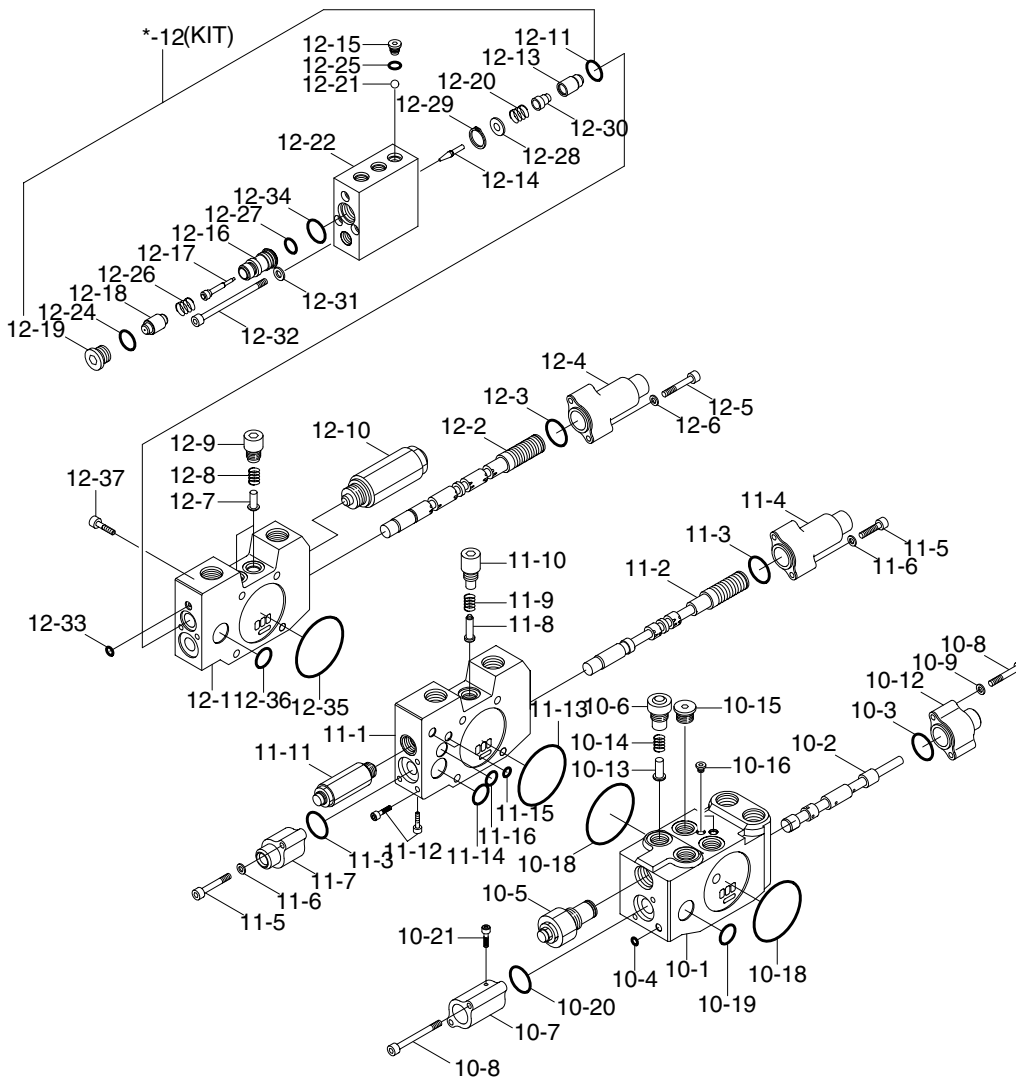

555W92MC04

10 Inlet block	10-21 Plug	12 Boom 1 block	12-19 Plug
10-1 Block	11 Travel block	12-1 Block	12-20 Spring
10-2 Travel straight spool assy	11-1 Block	12-2 Boom 1 spool assy	12-21 Steel ball
10-3 O-ring	11-2 Travel spool assy	12-3 O-ring	12-22 Pilot cover
10-4 O-ring	11-3 O-ring	12-4 Pilot cap (A)	12-24 O-ring
10-5 Main relief valve	11-4 Pilot cap (A)	12-5 Wrench bolt	12-25 O-ring
10-6 Plug 3	11-5 Wrench bolt	12-6 Plain washer	12-26 Spring
10-7 Pilot cap (B3)	11-6 Plain washer	12-7 Check poppet	12-27 O-ring
10-8 Wrench bolt	11-7 Pilot cap (B1)	12-8 Check spring	12-28 Spring seat
10-9 Plain washer	11-8 Check poppet	12-9 Plug	12-29 Snap ring
10-12 Pilot cap (B2)	11-9 Check spring	12-10 Overload relief valve	12-30 Resistor
10-13 Check poppet	11-10 Plug	12-11 O-ring	12-31 Plain washer
10-14 Check spring	11-11 Overload relief valve	12-13 Holding poppet	12-32 Wrench bolt
10-15 Plug	11-12 Set screw	12-14 Pilot poppet	12-33 O-ring
10-16 Plug	11-13 O-ring	12-15 Plug	12-34 O-ring
10-18 O-ring	11-14 O-ring	12-16 Piston guide	12-35 O-ring
10-19 O-ring	11-15 O-ring	12-17 Piston	12-36 O-ring
10-20 O-ring	11-16 O-ring	12-18 Pilot piston	12-37 Socket bolt

## STRUCTURE (4/4)

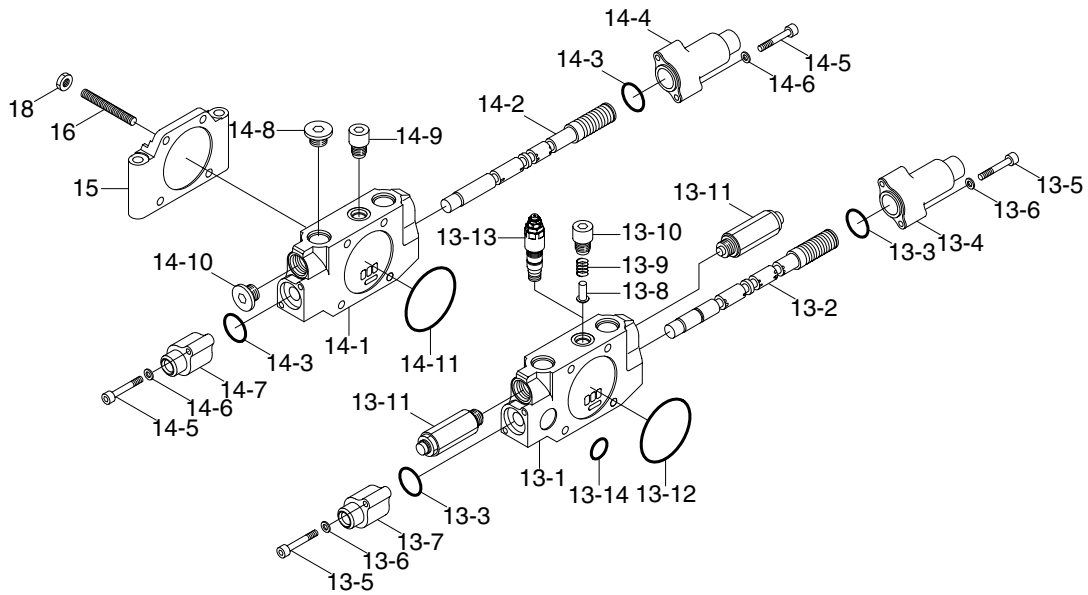

555W92MC05

13	Bucket block	13-10	Plug	14-5	Wrench bolt
13-1	Block	13-11	Relief valve	14-6	Plain washer
13-2	Bucket spool assy	13-12	O-ring	14-7	Pilot cap (B1)
13-3	O-ring	13-13	Check valve	14-8	Plug
13-4	Pilot cap (A)	13-14	O-ring	14-9	Plug
13-5	Wrench bolt	14	Arm 2 block	14-10	Plug
13-6	Plain washer	14-1	Block	14-11	O-ring
13-7	Pilot cap (B1)	14-2	Arm 2 assy	15	Cover
13-8	Check poppet	14-3	O-ring	16	Tie bolt
13-9	Check spring	14-4	Pilot cap (A)	18	Nut

### 3. HYDRAULIC CIRCUIT

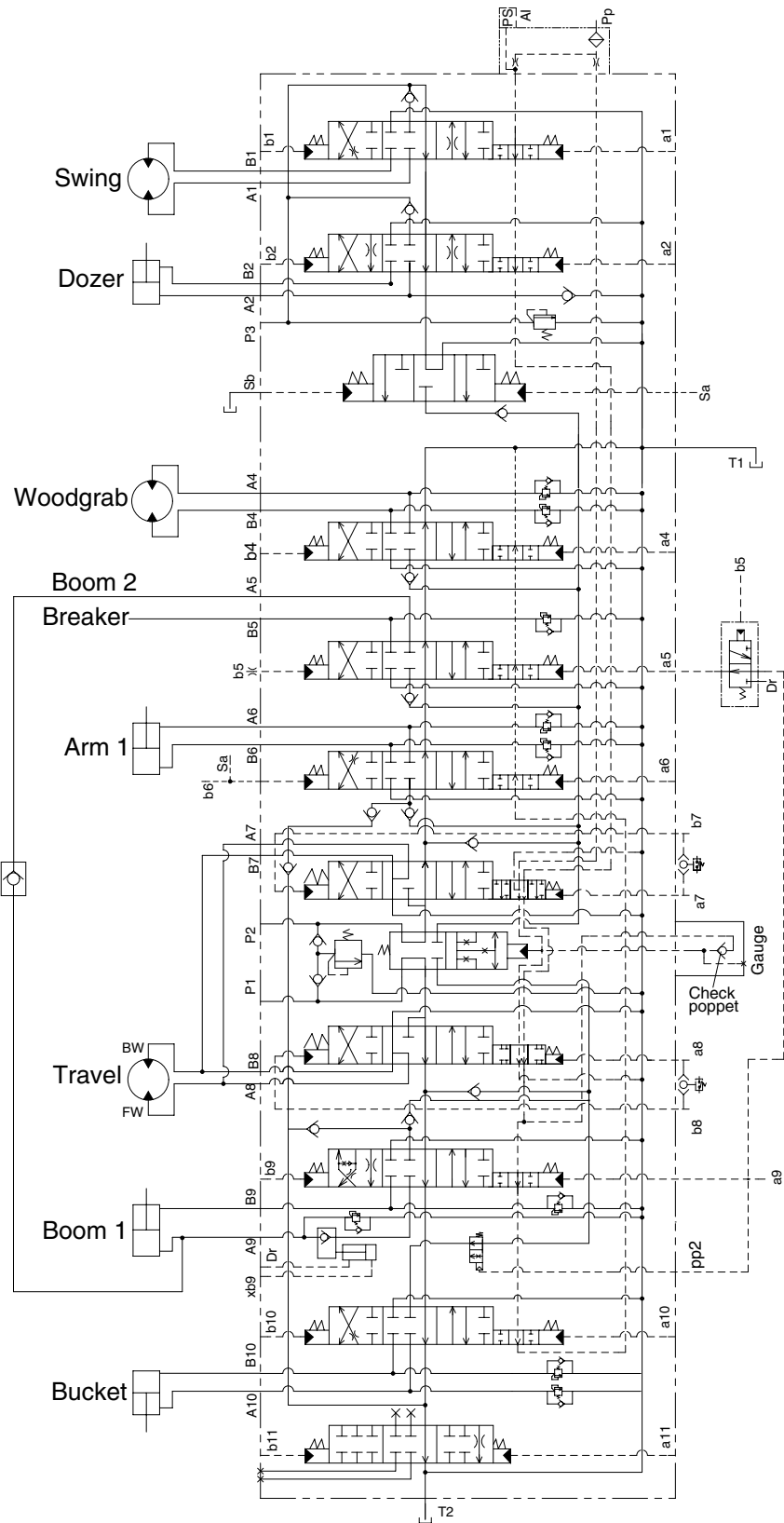

#### 4. FUNCTION

##### 1) CONTROL IN NEUTRAL FUNCTION

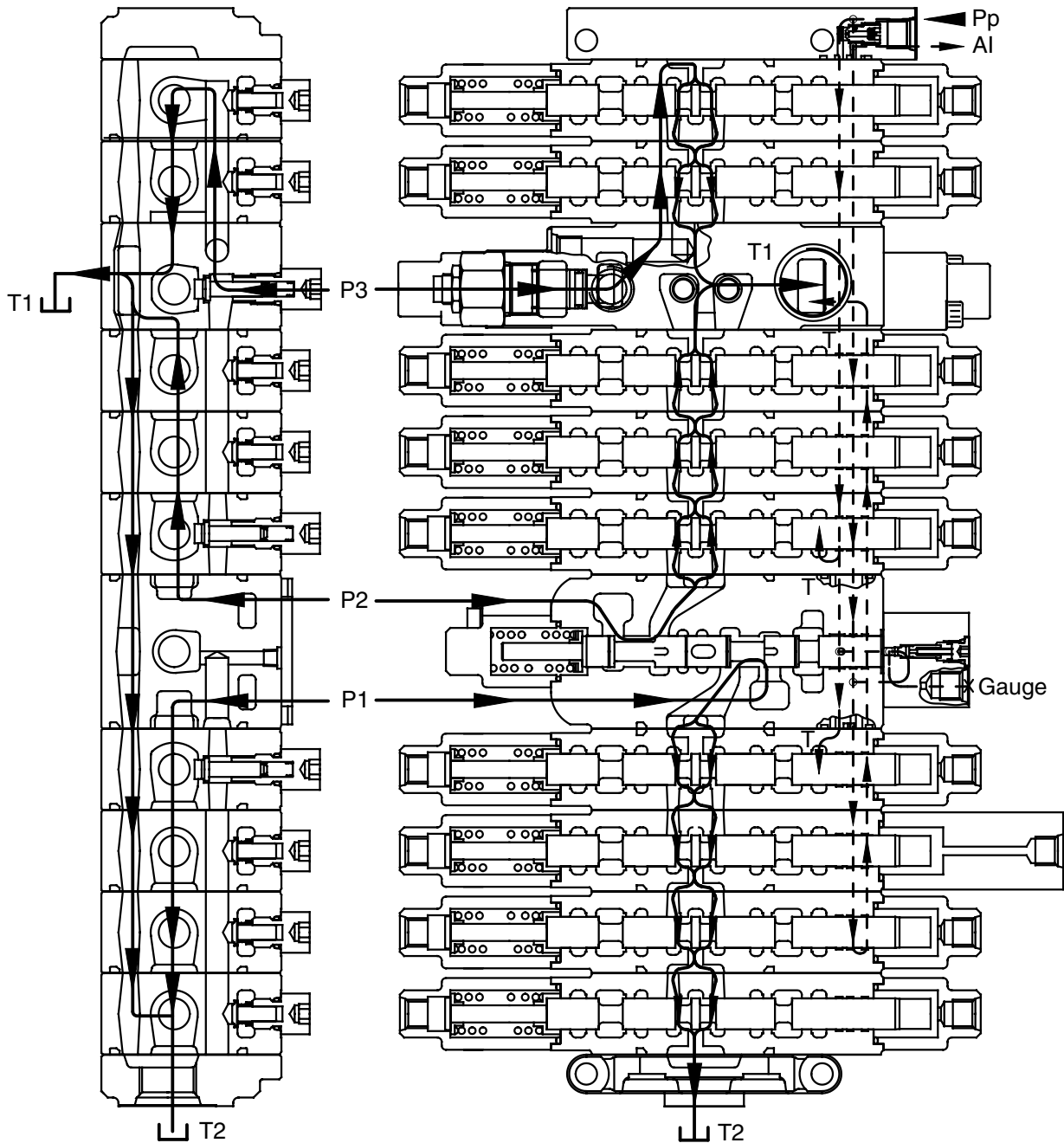

55W92MC02

In neutral, spring sets the spool at the neutral position, the hydraulic oil from pumps flows to the tank through the center bypass.

**(1) P1**

The oil discharged from the hydraulic pump flows into control valve P1 port, and then flows the right side travel valve through the travel straight valve. In neutral, the oil flows through the center bypass passage in the direction of right travel → boom 1 → bucket → arm 2 spool, and then flows from the center bypass passage to the tank port T1 and T2.

**(2) P2**

The oil discharged from the hydraulic pump flows into control valve P2 port, and then flows the left side travel valve through the travel straight valve. In neutral, the oil flows through the center bypass passage in the direction of left travel → arm 1 → boom 2/breaker spool, and then flows from the center bypass passage to the tank port T1 and T2.

**(3) P3**

The oil discharged from the hydraulic pump flows into control valve P3.

In neutral, the oil flows through the center bypass passage in the direction of swing → dozer spool, and then flows from the center bypass passage to the tank port T1 and T2.

**(4) Pp**

When Pp port is applied with pilot pressure, the oil flows into the swing block through TS signal passage and Ai signal passage independently via an orifice.

With the spool in neutral, the oil flows into the tank passage through the all section of the control valve(except arm 2 section). As a result, the TS valve is not shifted and the auto idle signal pressure is not raised.

## 2) EACH SPOOL OPERATION

### (1) Travel operation (forward / backward)

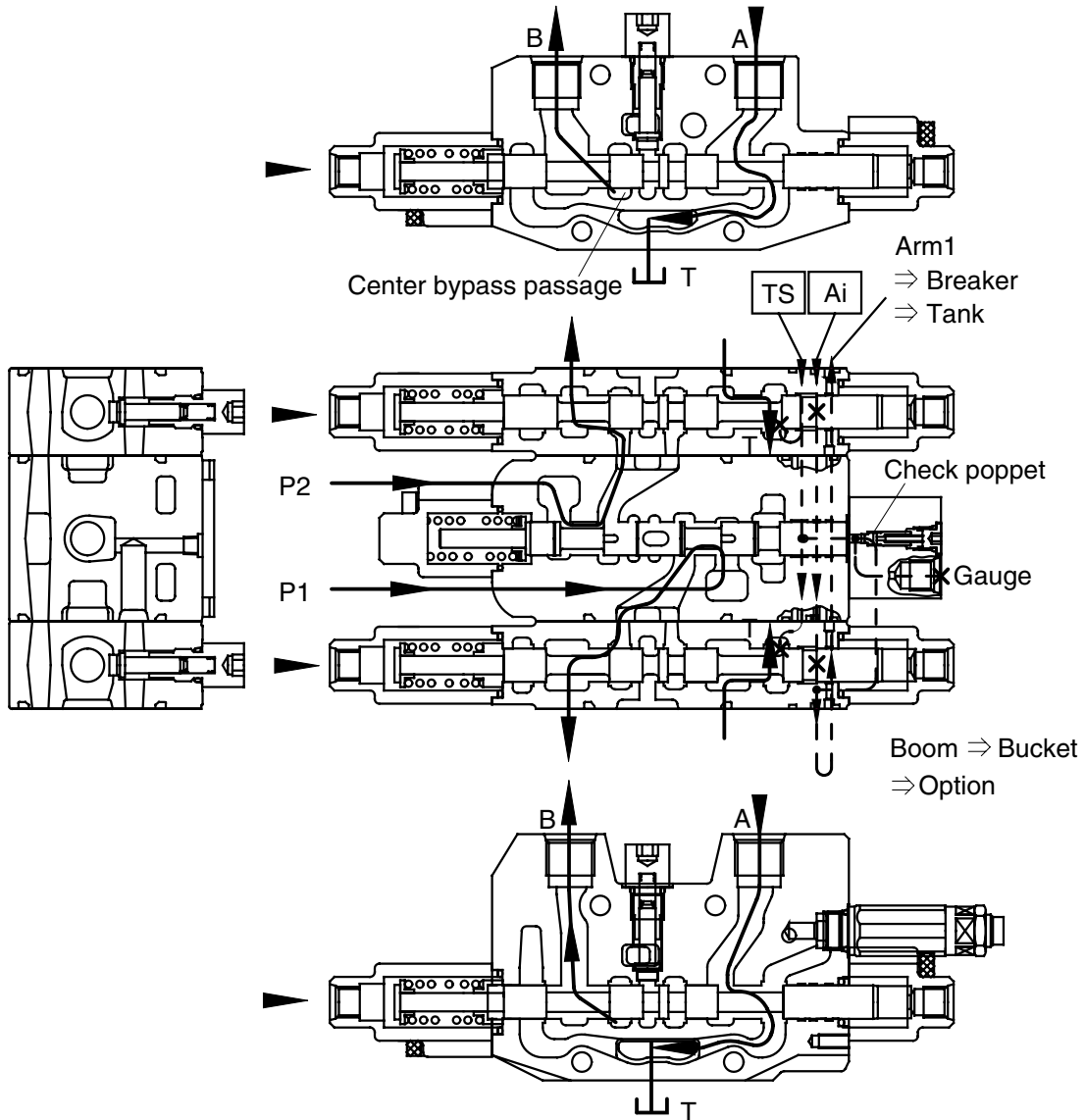

55W92MC03

- During travel (forward/backward) operation, the pilot pressure from RCV is supplied into the travel pilot port and shift the travel spool in the right direction.
- The hydraulic oil fluid from pump is entered center bypass passage of inlet block (P1, P2) and then flows into the port of travel motor.
- The oil from the port A of travel motor flows into the main control valve and return to the hydraulic oil tank through the tank passage.
- The TS signal passage is shut off by shifting of the travel spool, but it is connected with Ai signal passage and drain to the hydraulic oil tank. As a result, the travel straight spool is not shifted.
- The Ai signal passage is connected with travel block through swing and dozer block and it is shut off by shifting of the travel spool and then signal pressure of auto idle is raised.

(2) Boom operation

① Boom up operation (P1 and P2 summation)

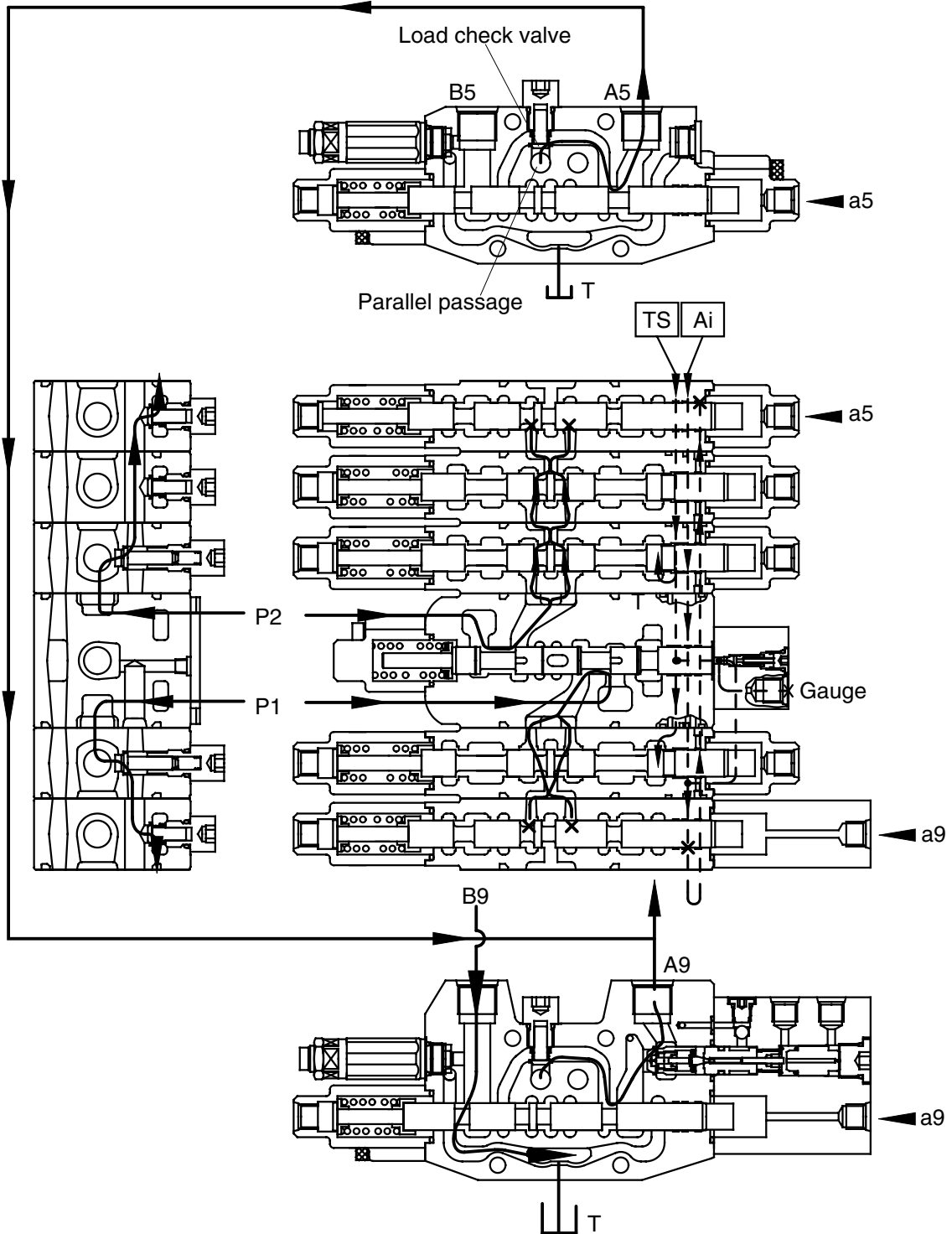

55W92MC04

- During boom up operation, the pilot pressure from RCV is supplied into the port a9 and shift the boom 1 spool in the left direction. The hydraulic oil fluid from pump P1 is entered P1 parallel passage and then passes through the load check valve then flows into the port A9. Following this, it flows into the head side of the boom cylinder.  
At the same time the pilot pressure through the port a5 shifts the boom 2 spool. The hydraulic oil fluid from pump P2 is entered P2 parallel passage and then passes through the load check valve then flows into the port A5. The flows combine in hydraulic hoses and are directed to the cylinder head side of boom cylinder.  
The flow from rod side of the boom cylinder return to the boom 1 spool through the port B9. There after it is directed to the hydraulic oil tank through the tank passage.
- The TS signal passage oil from the Pp port is drain to the hydraulic oil tank through the left/right travel valve and the signal pressure is not raised.
- The Ai signal passage oil from the Pp port is shut off by shifting of the boom 1 spool and then signal pressure of auto idle is raised.

## ② Boom down operation

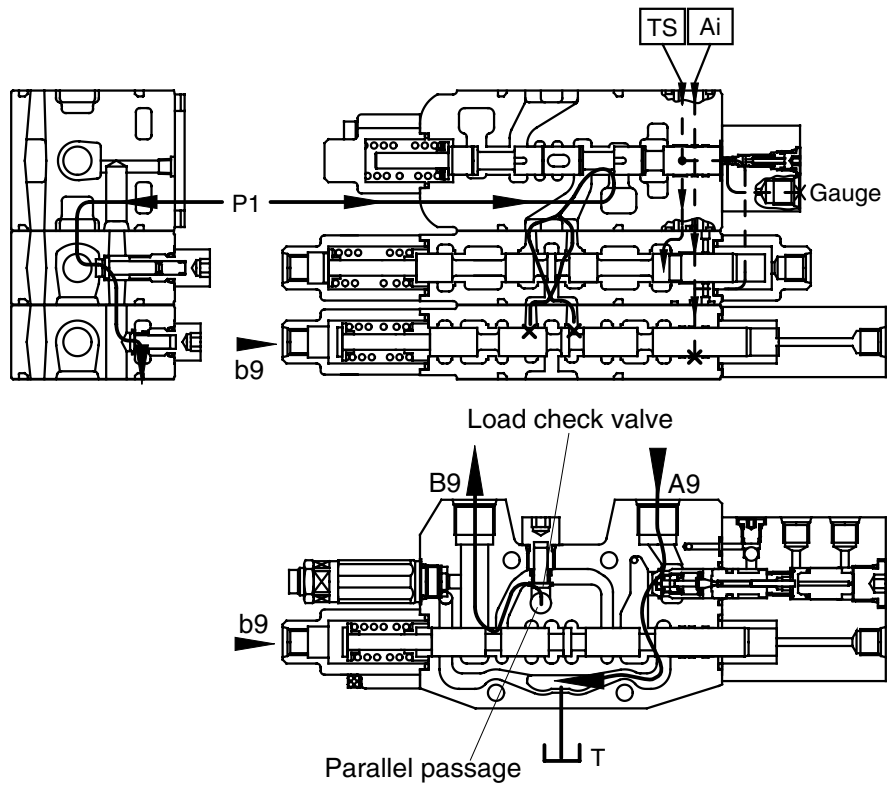

55W92MC05

- During the boom lowering operation, the pilot pressure from RCV is supplied to the port b9 and shift the boom 1 spool in the right direction.  
The hydraulic fluid from the pump P1 enters the parallel passage and is directed to the port B9 through the load check valve. Following this, it flows into the rod side of the boom cylinder.  
The return flow from the head side of the boom cylinder returns to the boom 1 spool through the port A9. Thereafter it is directed to the hydraulic oil tank through tank passage.
- The hydraulic oil flow from the Pp port is same as the boom up operation.

### (3) Bucket operation

#### ① Bucket roll in operation

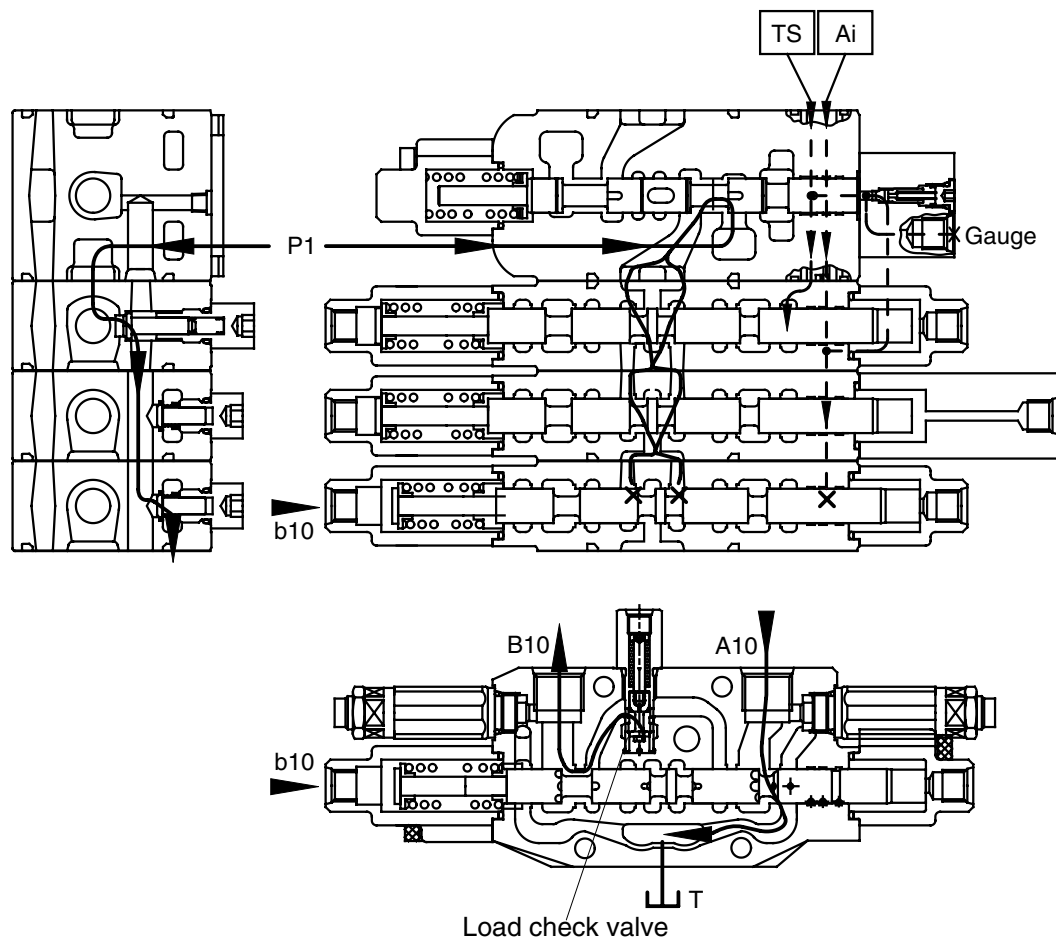

55W92MC06

- During the bucket roll in operation, the pilot pressure from RCV is supplied to port b10 and shift the bucket spool in the right direction.  
The hydraulic fluid from pump P1 entered P1 parallel passage and is directed to the port B10 through the load check valve.  
Following this, it flows into the head side of the bucket cylinder.  
The return flow from the rod side of the bucket cylinder returns to the bucket spool through the port A10. Thereafter it is directed to the hydraulic oil tank through the tank passage.
- The TS signal passage oil from the Pp port is drain to the hydraulic oil tank through the left/right travel valve and the signal pressure is not raised.
- The Ai signal passage oil from the Pp port is shut off by shifting of the bucket spool and then signal pressure of auto idle is raised.

② Bucket roll out operation

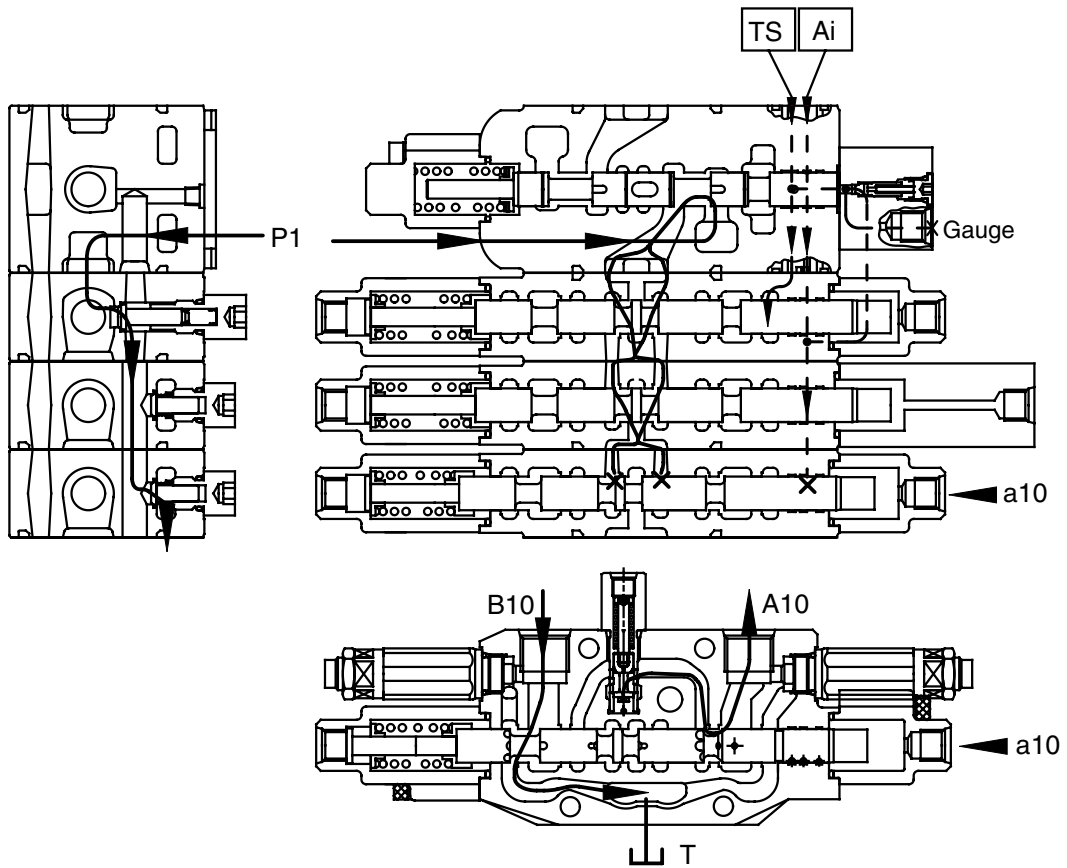

55W92MC07

- In case of the bucket roll out operation, the operation is similar.
- The hydraulic oil flow from the Pp port is same as the bucket in operation.

### ③ Bucket load check valve operation

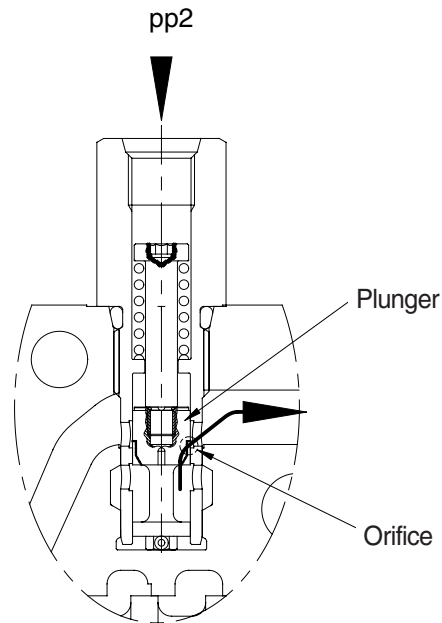

555C92MC13

- This function is used to speed up of the boom or arm by reducing the bucket speed when bucket operation with boom or arm operation simultaneously.
- When the signal pressure flows into port pp2, the plunger is shifted and orifice is made.
- The hydraulic oil from the port P1 flow into bucket cylinder via the orifice and then the speed of bucket cylinder is slow down.

Accordingly, the much fluid from the port P1 is supplied other cylinder than the bucket cylinder.

(4) Arm operation

① Arm roll in operation (P1 and P2 summation)

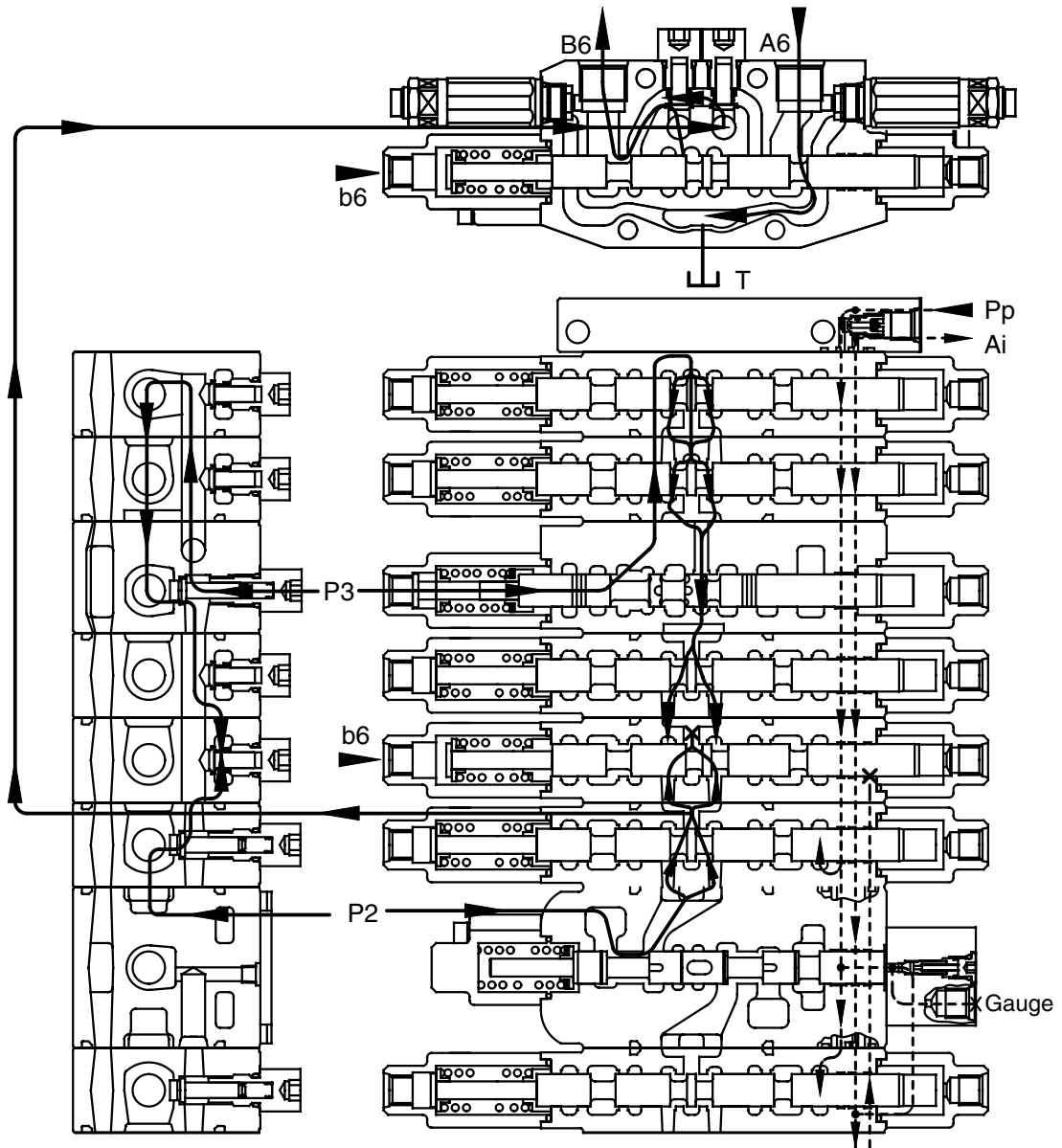

55W92MC08

- During arm roll in operation the pilot pressure from the RCV is supplied to the port b6 and shifts arm 1 spool in the right direction.
- Also, the pilot pressure is supplied to the port Sa through the external piping and shift the spool of P3 inlet block.

The hydraulic oil from the pump P2 flows into the arm cylinder head side through P2 parallel passage, the load check valve and the port B6.

At same time, the hydraulic fluid from the pump P3 flows into the arm summation passage in arm 1 spool through the P3 inlet spool. Then it entered the arm cylinder head side with hydraulic fluid from arm 1 spool.

- The TS signal passage oil from the Pp port is drain to the hydraulic oil tank through the left/right travel valve and the signal pressure is not raised.
- The Ai signal passage oil from the Pp port is shut off by shifting of the arm spool and then signal pressure of auto idle is raised.

## ② Arm roll out operation

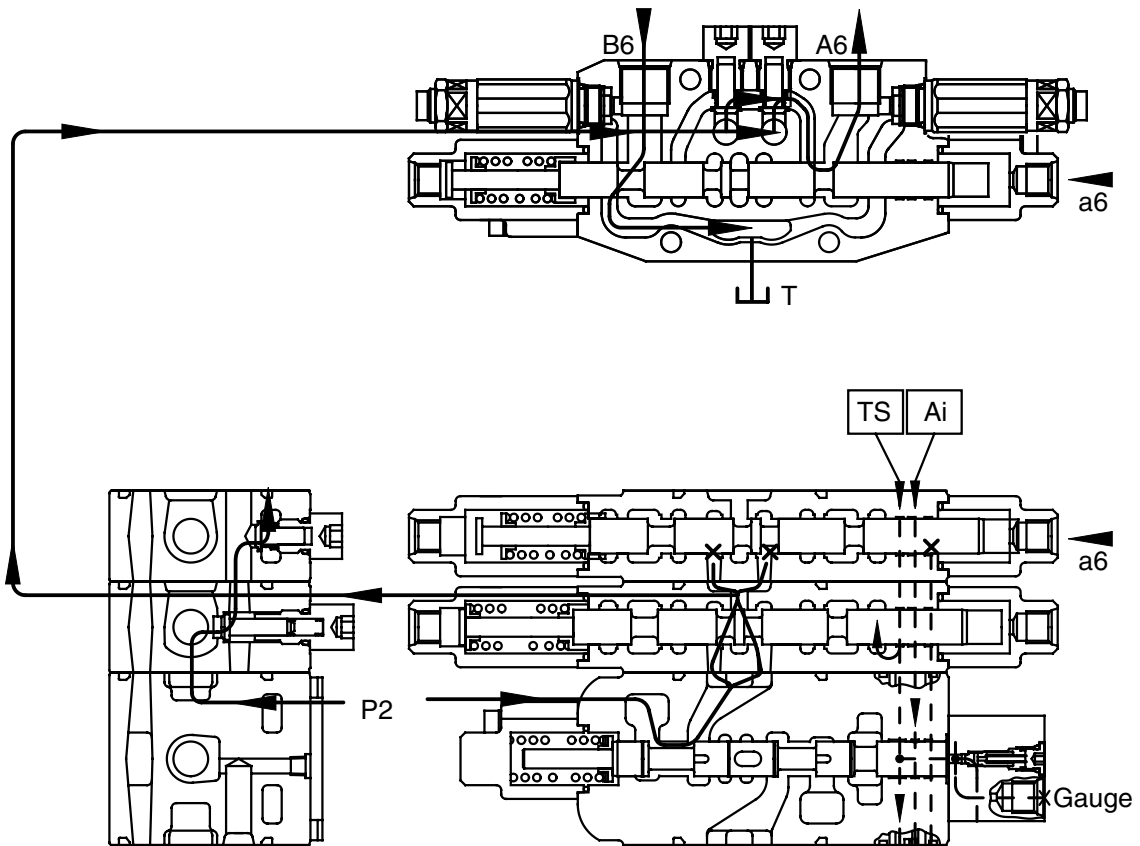

55W92MC09

- During arm roll out operation the pilot pressure from RCV is supplied to the port a6 and shifts arm 1 spool in the left direction.  
The hydraulic fluid from pump P2 flows into arm 1 spool through the parallel passage. Then it enters into the arm cylinder rod side through the load check valve and the port A6.  
The return flow from the arm cylinder head side returns to the hydraulic tank through the port B6 the arm1 spool and tank passage.
- The hydraulic oil flow from the Pp port is same as the arm roll in operation.

## (5) Swing operation

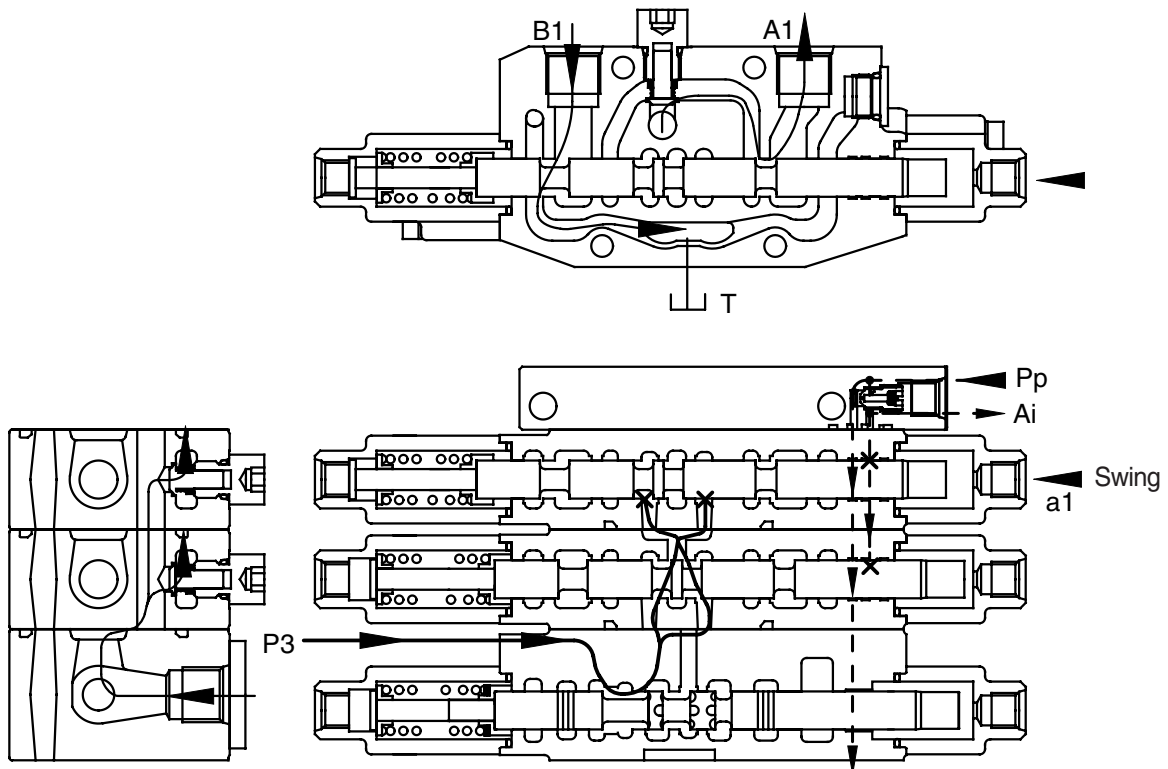

555C92MC16

- The pilot pressure from the RCV is supplied to the a1 and shift the swing spool in left direction. The hydraulic fluid from pump P3 flows into swing spool through the parallel passage. Then it is directed to swing motor through the port A1. As a result, swing motor turns and flow from the swing motor returns to the hydraulic oil tank through the port B1, swing spool and the tank passage.  
In case of swing left operation, the operation is similar.
- The TS signal passage oil from the Pp port is drain to the hydraulic oil tank through the left/right travel valve and the signal pressure is not raised.
- The Ai signal passage oil from the Pp port is shut off by shifting of the swing spool and then signal pressure of auto idle is raised.

(6) Travel straight spool

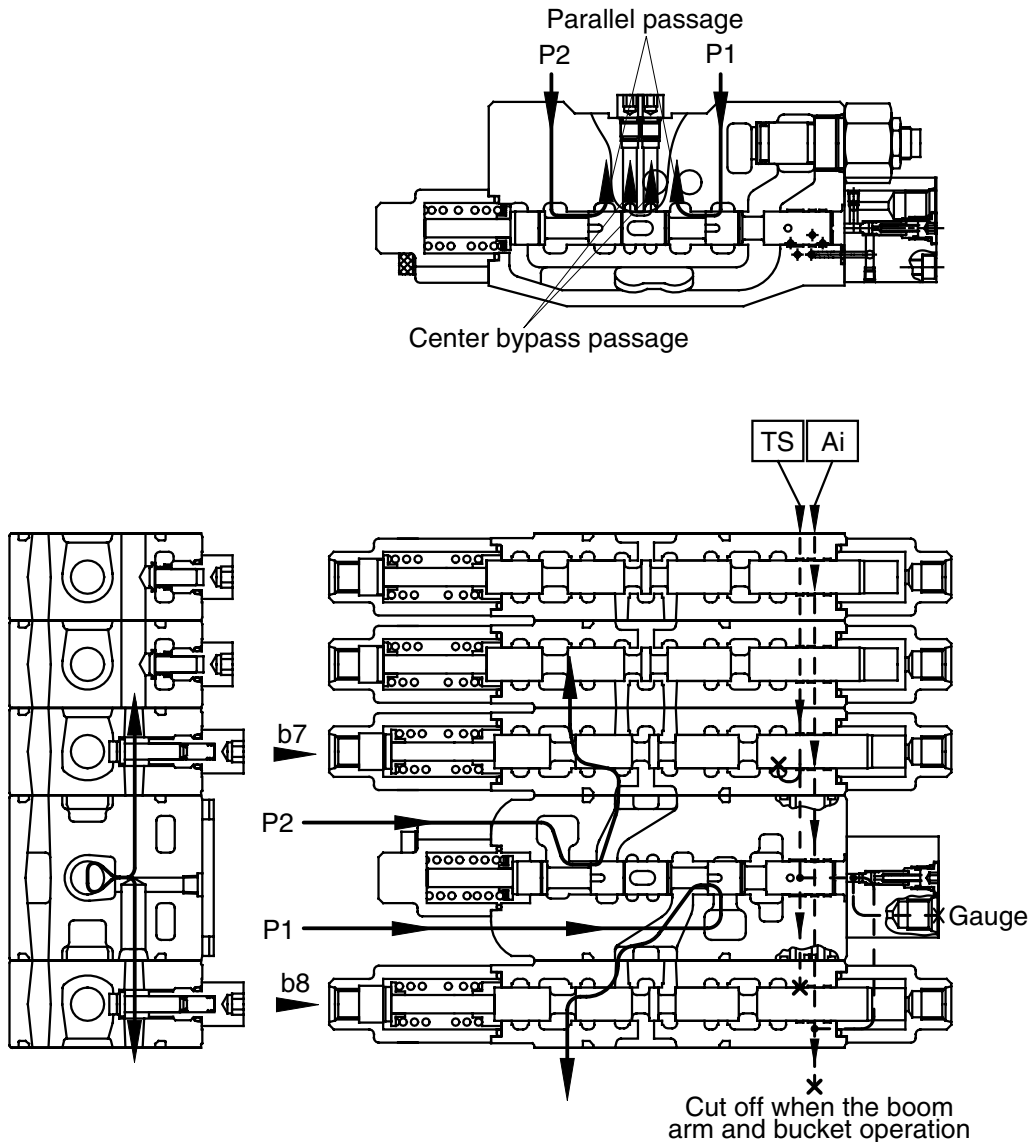

55W92MC10

① The other actuator operation during travel operation.

When the other actuator spool(s) is selected under travel operation, the straight travel spool is moved.

Some of hydraulic fluid from pump P1 and P2 is supplied to the travel motors through parallel passage and the other hydraulic fluid is supplied to the actuator(s) through center bypass passage via orifice passage.

Thus, the machine keeps the speed and power of the actuator and travel.

② The arm in operation during straight travel operation.

The arm in pilot pressure flows into P3 pilot port Sa through the external piping and the spool is shifted. As a result, the fluid of P3 pump is combined with the arm in operation through parallel passage and then the arm in speed up.

Refer to the arm in operation for the details.

## (7) Holding valve operation

### ① Holding operation

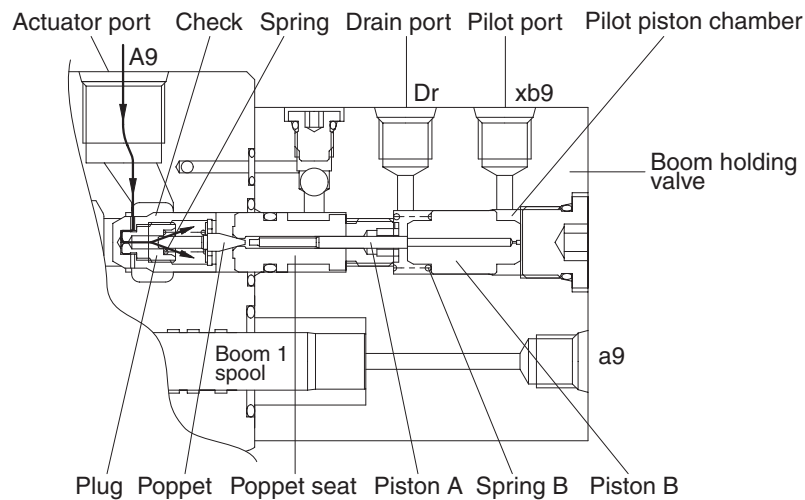

55W72MC16

At neutral condition, the pilot piston chamber is connected to drain port through the pilot port. And the piston "B" is supported with spring "B". Also, the pressured fluid from actuator entered to inside of the holding valve through the periphery hole of check, crevice of the check and the plug and the periphery hole of plug. Then, this pressured oil pushed the poppet to the poppet seat and the check to the seat of body. So the hydraulic fluid from actuator is not escaped and the actuator is not moved.

### ② Release holding operation

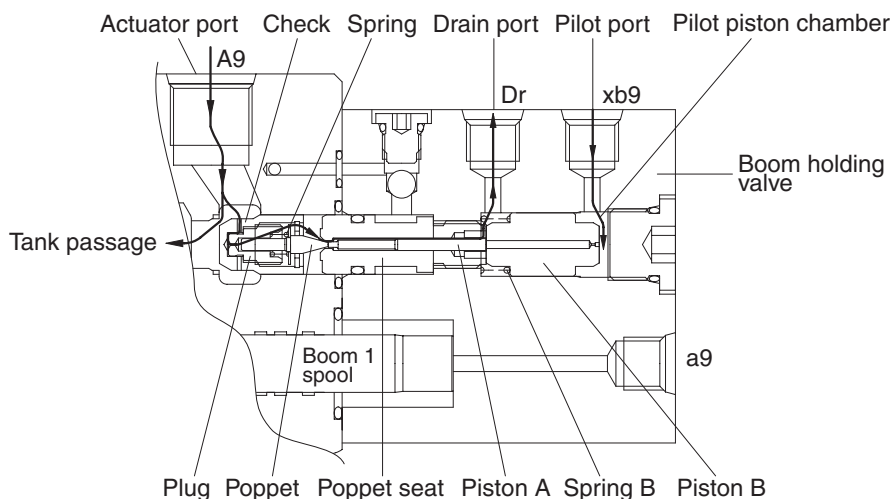

55W72MC17

The pilot pressure is supplied to the pilot port for release holding valve and shifts the piston "B" in the left direction against the spring "B", and shifts the poppet in the left direction through piston "B" and piston "A" against spring "B" and shifts the spool in the left side. At same time, the return fluid from actuator returns to the drain port through the periphery hole of check, crevice of the check and the plug, the periphery hole of the plug, in side of holding valve, crevice of the poppet and the poppet seat, the periphery hole of the poppet seat, crevice of socket and spool and internal passage of spool. When the poppet is opened, pressure of inside of holding valve is decreased and the return fluid from actuator returns to the tank passage through the notch of spool.