

## GROUP 9 FRONT AXLE

### 1. REMOVAL FRONT AXLE

- 1) Propeller shaft mounting nut(2, M10)
  - Tightening torque :  $7.4 \pm 1.5 \text{kgf} \cdot \text{m}$   
( $53.5 \pm 10.8 \text{lb} \cdot \text{ft}$ )
- 2) Wheel nut(3, M18)
  - Tightening torque :  $46 \pm 3.0 \text{kgf} \cdot \text{m}$   
( $333 \pm 21.7 \text{lb} \cdot \text{ft}$ )
- 3) Oscillating cylinder supporting mounting bolt(4, M12)
  - Tightening torque :  $12.8 \pm 3.0 \text{kgf} \cdot \text{m}$   
( $92.6 \pm 21.7 \text{lb} \cdot \text{ft}$ )
- 4) Front axle mounting pin lock bolt(1, M10)
  - Tightening torque :  $6.9 \pm 1.4 \text{kgf} \cdot \text{m}$   
( $49.9 \pm 10.1 \text{lb} \cdot \text{ft}$ )
- 5) Hose assy(5)
- 6) Front axle weight : 275kg(610lb)

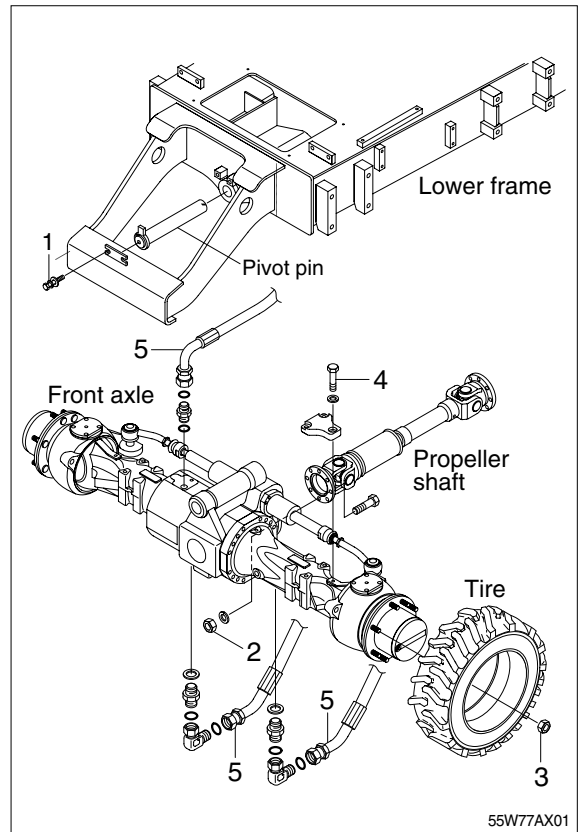

## 2. GENERAL INSTRUCTIONS

- 1) During all operations described in this manual, the axle should be fastened onto a trestle, while the other parts mentioned should rest on supporting benches.
- 2) When removing one of the arms, an anti-tilting safety trestle should be placed under the other arm.
- 3) When working on an arm that is fitted on the machine, make sure that the supporting trestles are correctly positioned and that the machine is locked lengthways.
- 4) Do not admit any other person inside the work area; mark off the area, hang warning signs and remove the ignition key from the machine.
- 5) Use only clean, quality tools; discard all worn, damaged, low-quality or improvised wrenches and tools. Ensure that all dynamometric wrenches have been checked and calibrated.
- 6) Always wear gloves and non-slip rubber shoes when performing repair work.
- 7) Should you stain a surface with oil, remove marks straight away.
- 8) Dispose of all lubricants, seals, rags and solvents once work has been completed. Treat them as special waste and dispose of them according to the relative law provisions obtaining in the country where the axles are being overhauled.
- 9) Make sure that only weak solvents are used for cleaning purposes; avoid using turpentine, dilutants and toluol-, xylol- based or similar solvents; use light solvents such as kerosene, mineral spirits or water-based, environment friendly solvents.
- 10) For the sake of clarity, the parts that do not normally need to be removed have not been reproduced in some of the diagrams.
- 11) The terms RIGHT and LEFT in this manual refer to the position of the operator facing the axle from the side opposite the drive.
- 12) After repair work has been completed, accurately touch up any coated part that may have been damaged.

### 3. BRAKE; SERVICE BRAKE, NEGATIVE BRAKE, 100% LOCKED

#### 1) Disassembly

- (1) Remove the screws of the planetary gearbox cover on the brake side.  
Remove the planetary gearbox cover.

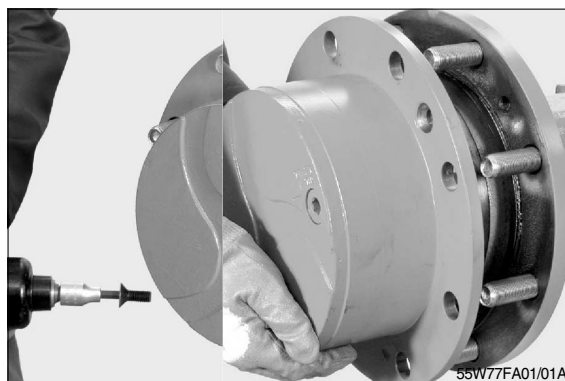

- (2) Remove the axle half shaft.

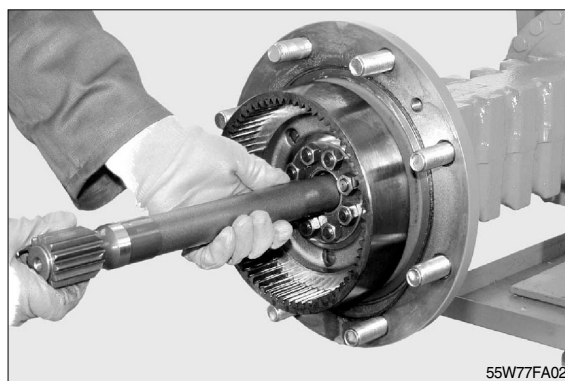

- (3) Sling the arm to be removed and connect it to a hoist, remove screws.

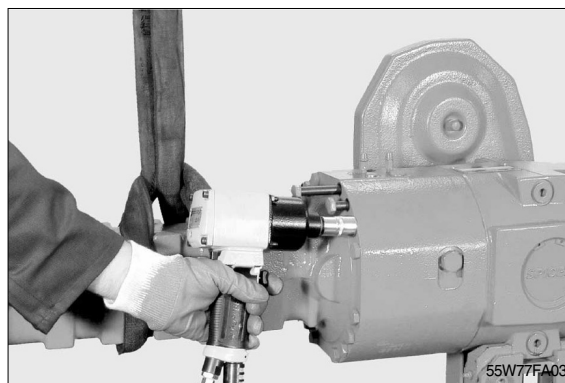

- (4) Take off the arm and lay it down vertically.

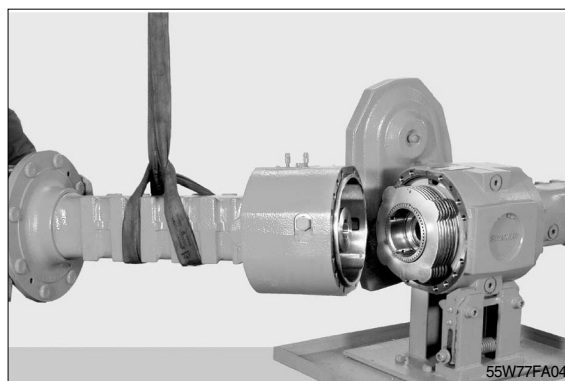

- (5) In order to keep the disc springs of the negative brake preloaded, screw down the screws with washers to the end stop.



- (6) Loosen the before installed provisional screws in the same sequence and same measure.



- (7) Insert the screws of the puller(M12) into the tapholes of the negative brake and remove the pistons of the brake.

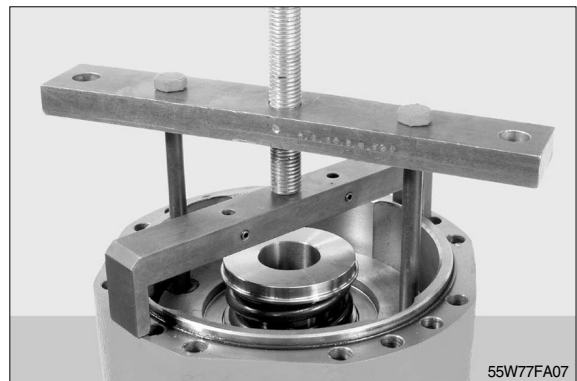

- (8) Pull out brake piston assembly module.

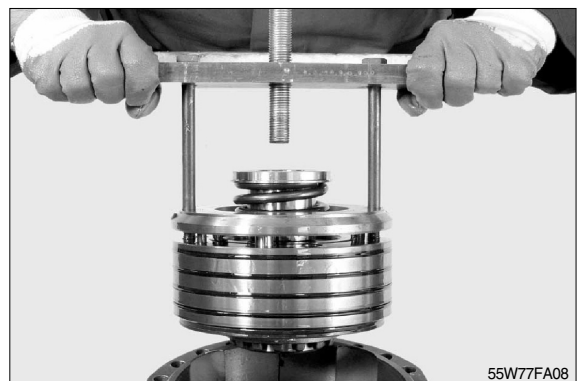

(9) Check locking screw(33) of the brake piston module.

※ Attention!

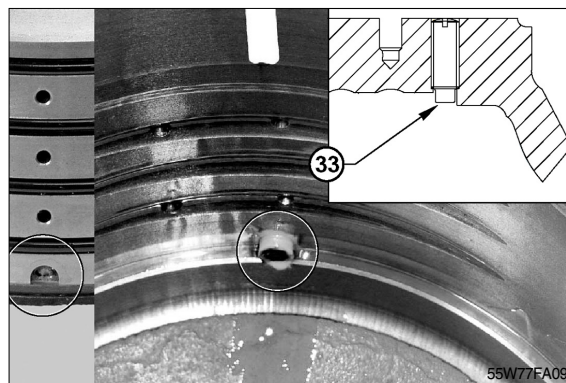

(10) Remove intermediate disc(2).

※ Sign the assembly position.



(11) Applying pressure to the first hole, remove the service brake piston(7).



(12) Applying pressure to the second hole, remove the hydraulic block piston(12).



(13) Applying pressure to the third hole, remove the three bolts(24).

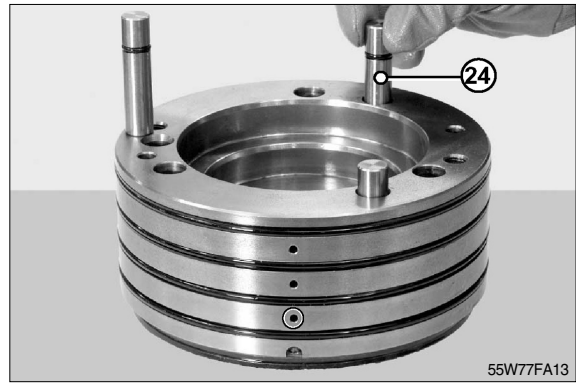

(14) Turn upside down the brake module and with a pin driver remove the locking pin of the slotted nut.



(15) Sign the position of the slotted nut.

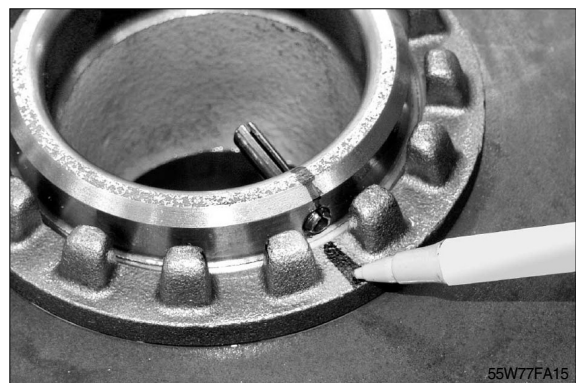

(16) Unscrew the slotted nut(29).

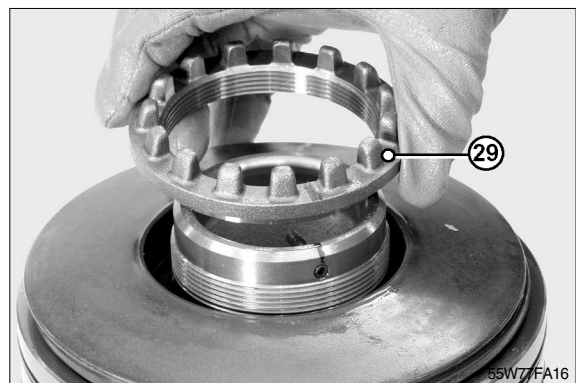

(17) Remove the disc springs(28).



(18) Applying pressure, remove the piston(27) of the negative brake.



(19) Check the position of the anti-extrusion (8)(10)(14)(5) and O-ring(9)(10)(13)(6).

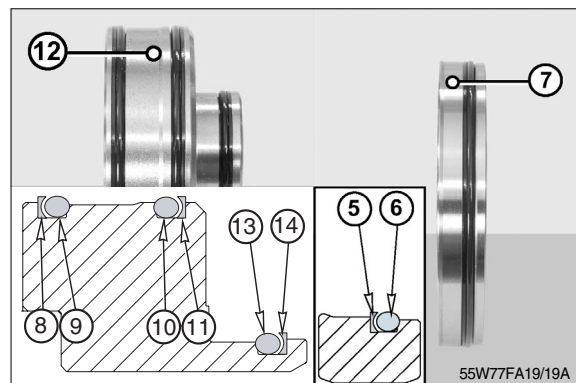

(20) Check the position of the O-rings(25)(26).

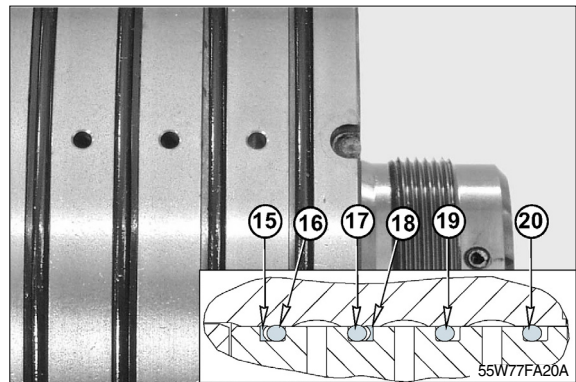
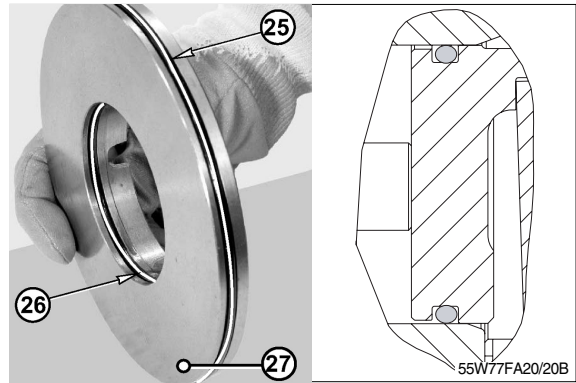

(21) Remove the snap ring(4) from the intermediate disc(2).

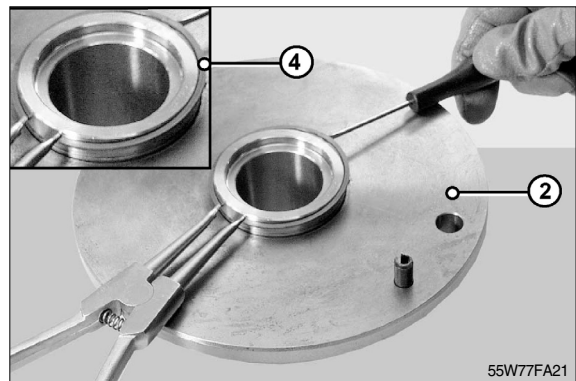

(22) Remove coupling(40) and washers(45).  
※ Build a stack of washers and check the measure.

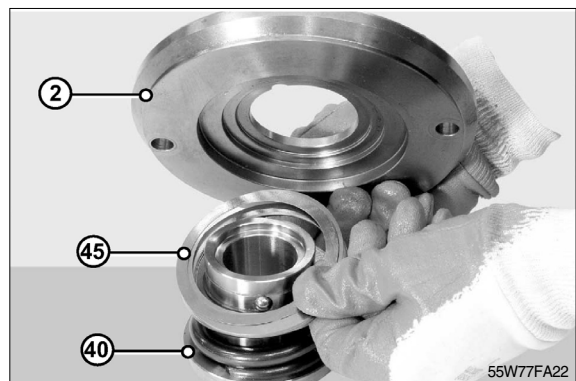

(23) Using a puller, preload the spring(42).



(24) Remove the snap ring(44).  
※ Spring preloaded.



(25) Remove the fixing ball(41).

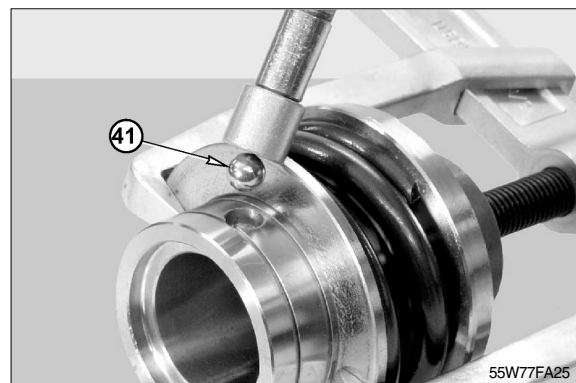

(26) Remove the spring(42) and washer(43).

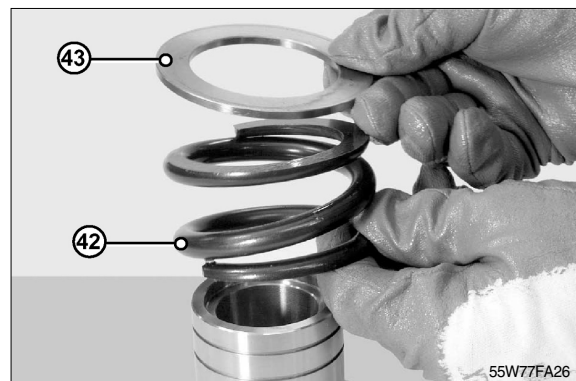

(27) Remove the snap ring of the brake stack.

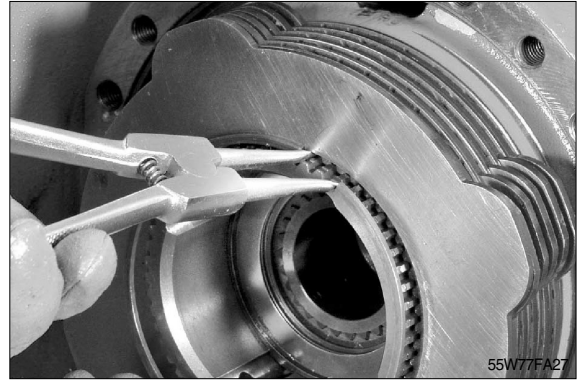

(28) Remove the brake discs one after the other(39)(38).

※ If they are not to be substituted, do not mix up the sequence.

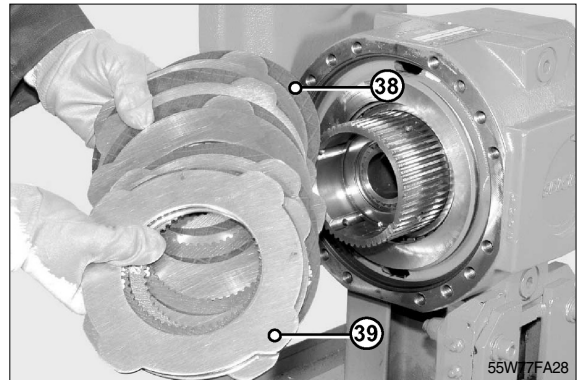

## 2) Assembly

- (1) Insert spring(43) and washer(42) onto the hydraulic block coupling.

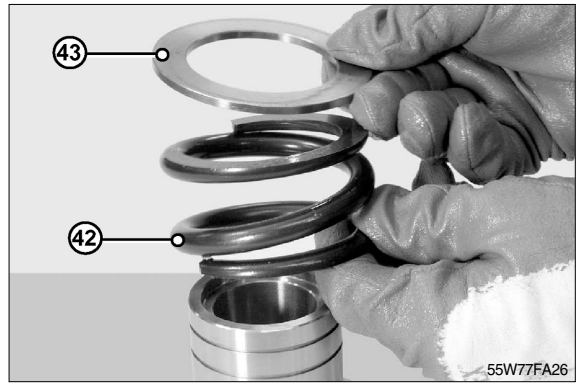

- (2) Preload the spring(42) by using a puller acting on the washer(43). Insert the snap ring(44) and the fixing ball(41).

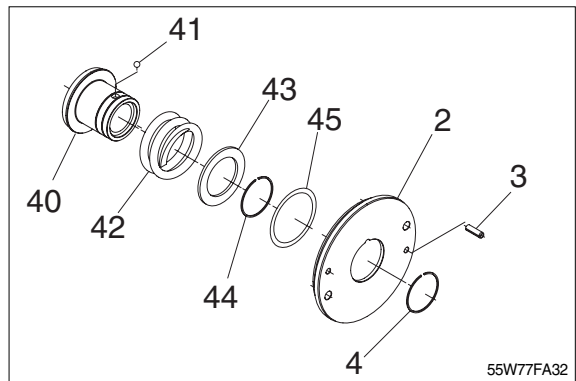
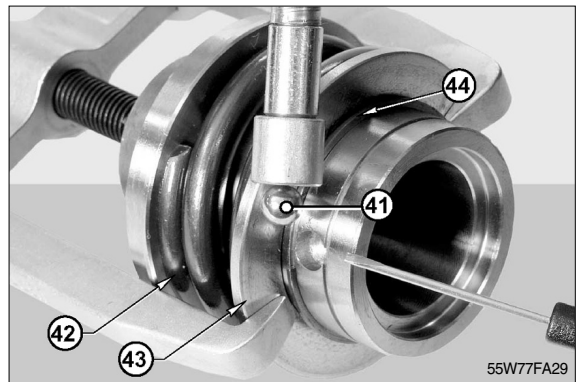

- (3) Shift the cut of the snap ring(15) according to the ball(41).



- (4) Complete the O-rings and anti-extrusion rings on all pistons.  
 ※ The O-rings always have to be assembled from the pressure facing side.

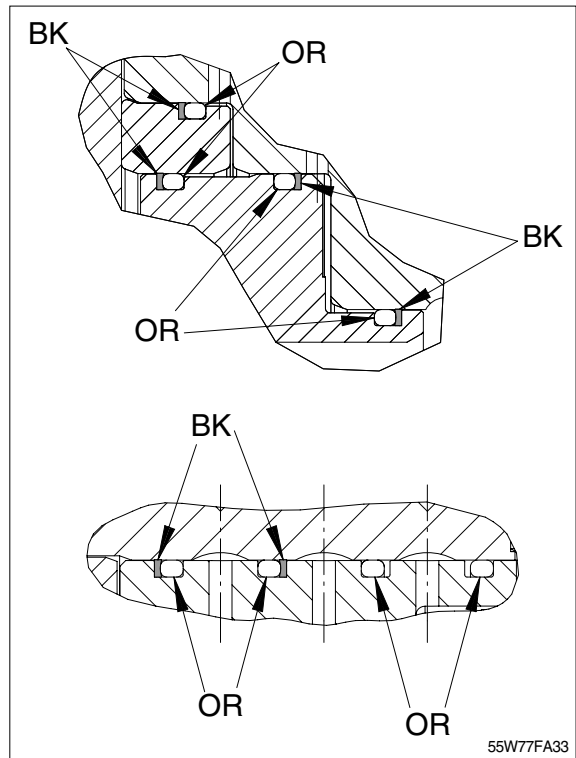
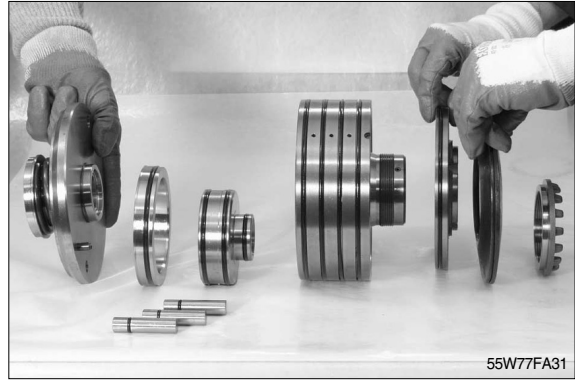

- (5) Insert the bolts(24).

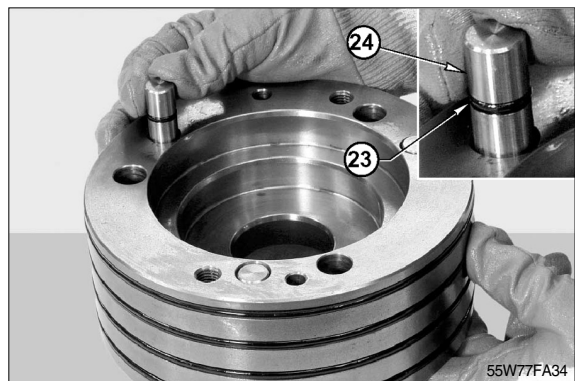

(6) Insert the hydraulic block piston(12).

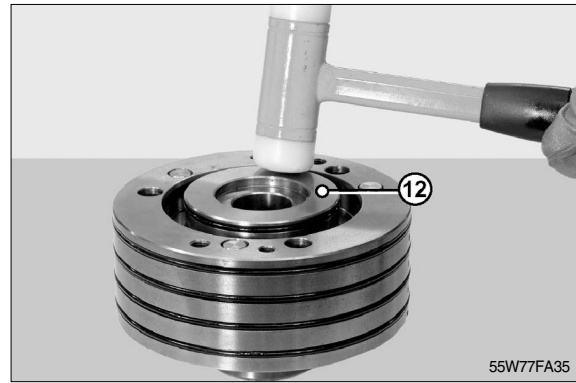

(7) Insert the service brake piston(7) hammering alternately with a plastic hammer.



(8) Insert the intermediate disc(2) observing the previously signed position.



(9) Turn upside down and insert the negative brake piston(27).



(10) Screw up the slotted nut(29) for about 5 turns.

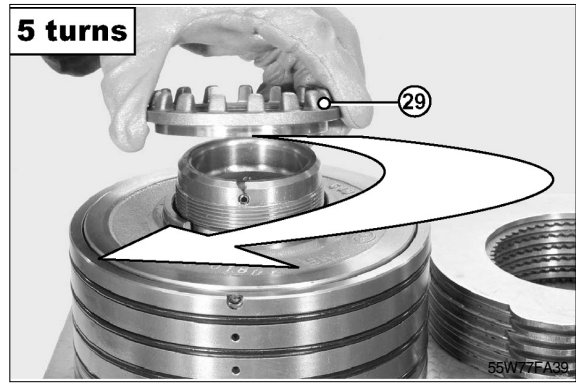

(11) Find out the level of the brake discs "D".  
E.g. D = 44.7mm  
Add to D the value G = brake clearance  
(e.g. 1.4mm).  
 $D + G = 44.7 + 1.4 = 46.1$

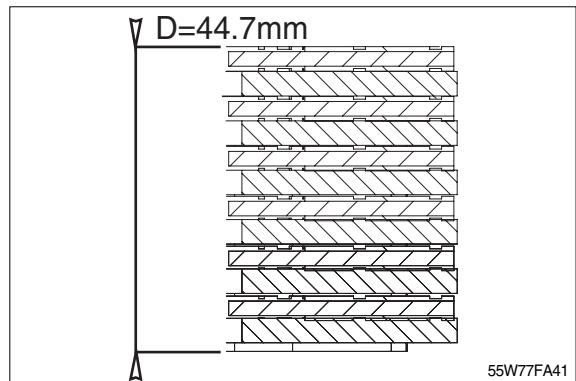
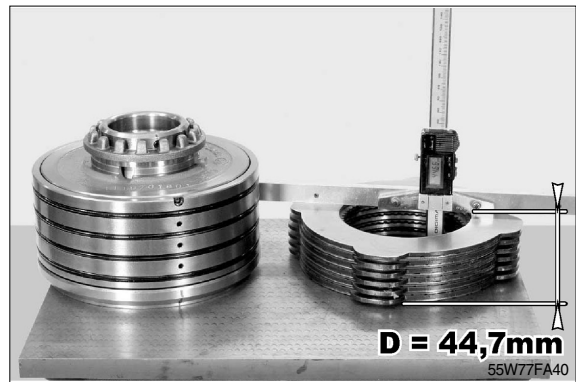

(12) Determine the level "A" between external plane and the brake plate by the adjustment of the slotted nut.

NOTE : To define the level A adjust the slotted nut always to the smaller value by driving to the closer notch.

$$A = 141 - (D+G) = 141 - 46.1 = 94.9\text{mm}$$

X = constant value 141mm

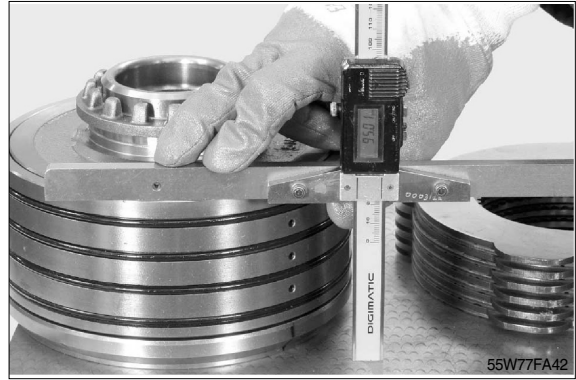

(13) To determine the level A the slotted nut has to be operated without spring mounted.

※ Attention!



(14) Before removing the slotted nut in order to insert the springs, note down the distance Z from the plane to the tooth near the pin.

※ Sign!

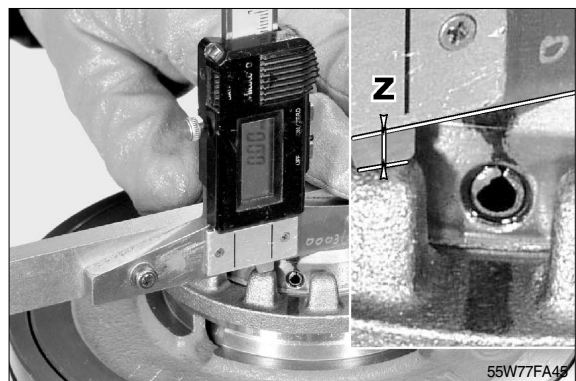

(15) Turn upside down and fit on the intermediate disc(2).

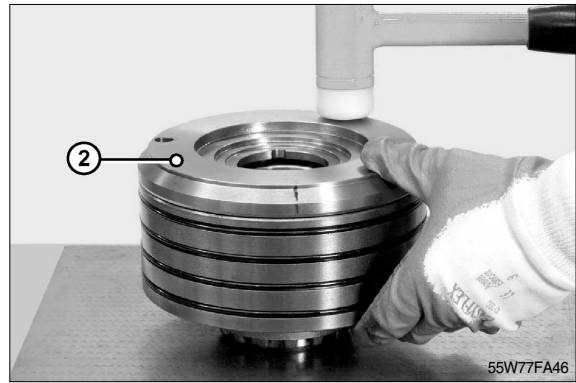

(16) Select a pack of washers(20) of 1.5mm  
 $S_4 = 1.5\text{mm const.}$



(17) Insert and bring into position washers(45) and coupling(40) into the brake module (22).

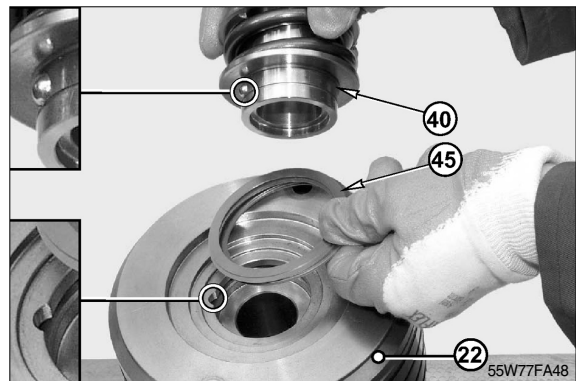

(18) With the positioned pack determine the distance L between coupling and brake disc surface.  
E.g.  $L = 37.5\text{mm}$



(19) Insert the brake discs(38) in the right sequence.

- ※ The first brake disc to be inserted must be of friction material.

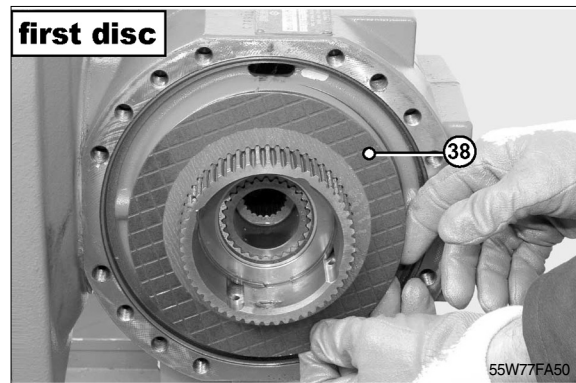

(20) Insert the brake discs(39) in the right sequence.

- ※ The last brake disc to be inserted must be of metal material.

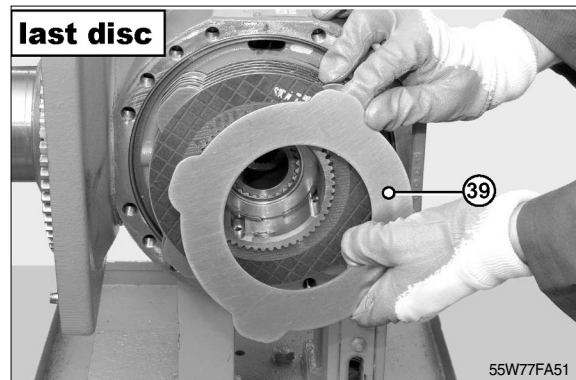

(21) Zero the depth gage from the plane of the splined coupling to the surface of the brake discs.

- ※ Press the brake disc pack before zeroing, execute the measurement in some points and take an average.

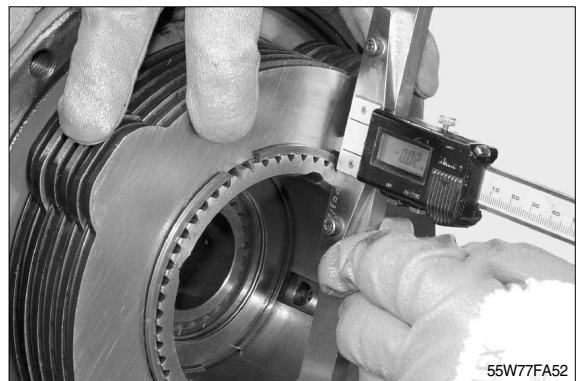

(22) Check of the clearance "R" between coupling and thrust bearing. Find out the distance "M" between the brake discs surface and thrust bearing.

※ M=36.4mm

Brake discs clearance G=1.4

$R=(M+G)-L=(34.6+1.4)-37.5=0.3\text{mm}$

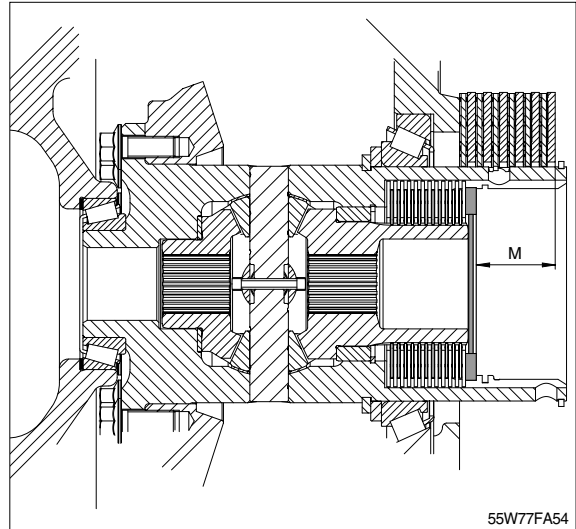
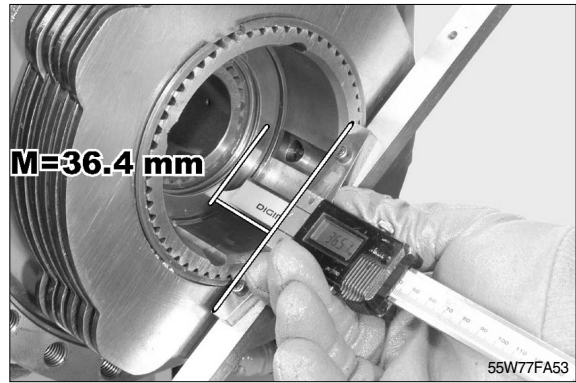

M=Needle bearing distance

(23) Correction of the shims S4 depending on the calculation of the value "R"

※ The value of "R" has always to result in 0.1mm in case it is not so, the shims S4 (45) under the coupling(40) have to be modified.

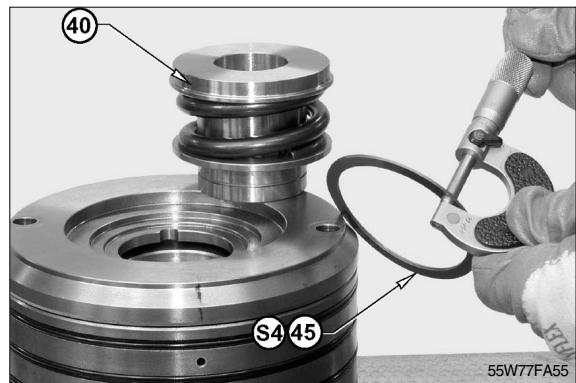

(24) Depending on the calculation assemble the exact shims to arrive at R=0.1mm.

Assemble all with safety ring.

Where 1.5 const. Shims S4 z.B.:  $S4=1.5+(0.3-0.1)=1.5+0.2=1.7\text{mm}$

0.3mm = R calculated clearance

0.1mm = R wanted clearance



(25) Insert the complete intermediate disc(2).



(26) Turn upside down and unscrew the slotted nut(29).



(27) Insert the disc springs in the right position (28).

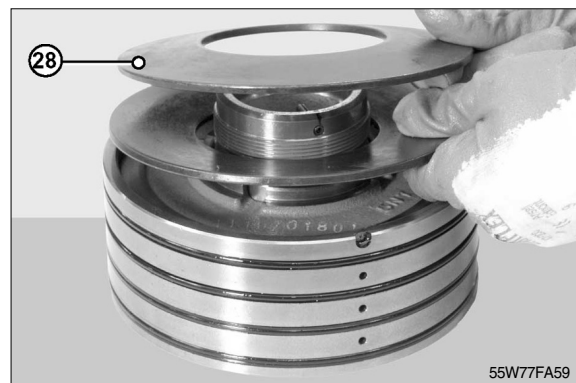

(28) Insert at the bottom the piston of the negative brake(27) and screw up the slotted nut(29).

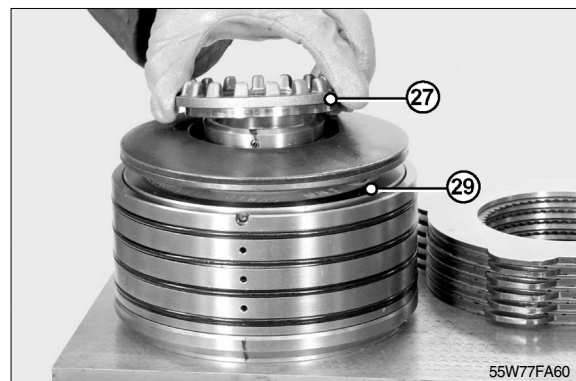

(29) Screw down the slotted nut to the earlier determined position.

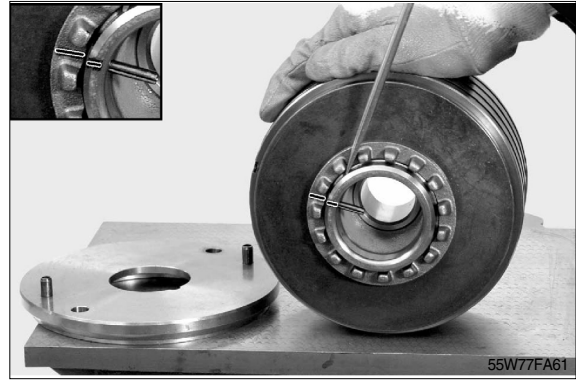

(30) Check the earlier measured distance Z from the plane Z from the plane to the tooth next to the pin.

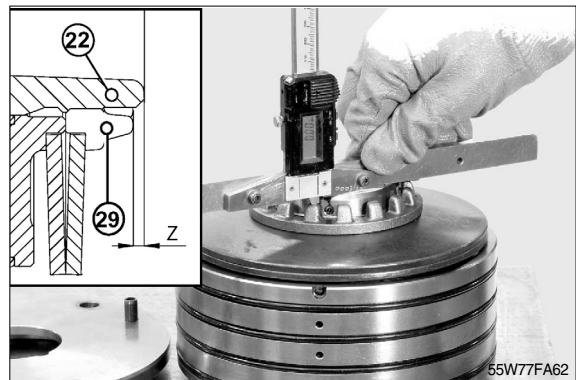

(31) Put the pin in locking(21) position.

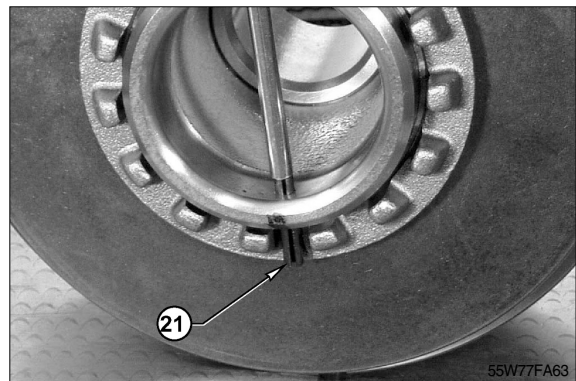

(32) Insert two screws of M12 to fix the break arm.



- (33) Position the groove of the brake module in line with the lock screw in the arm.  
※ Attention!



- (34) Check locking screw(33) of the brake piston module.  
※ Attention!

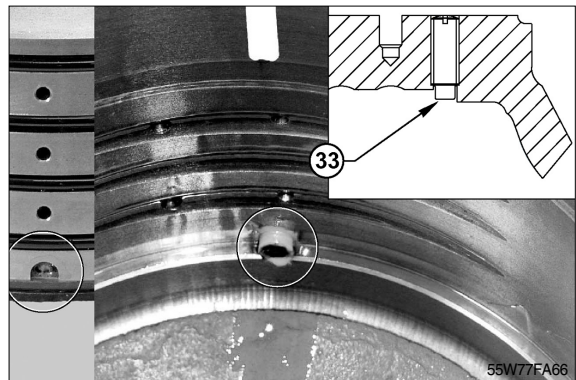

- (35) Insert the brake module facing the input holes to the top.



- (36) Insert the piston to the end stop by alternating light strokes and remove the screws.



(37) Temporary insert screws M12 × 45

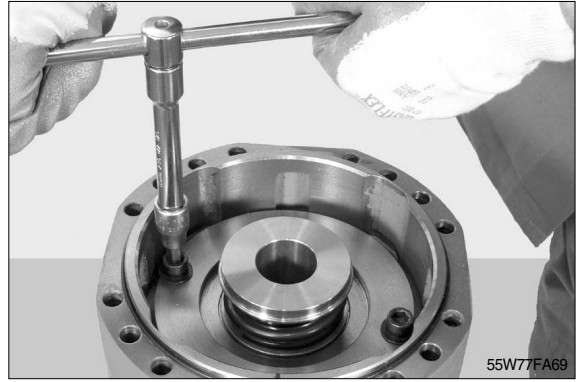

(38) Alternately tighten with a torque wrench setting of max. 45Nm(33.2lbf · ft)

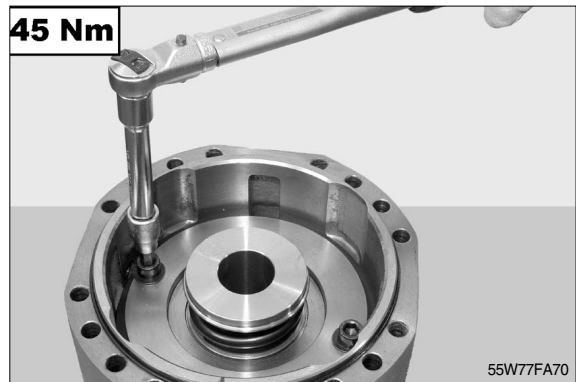

(39) Insert the negative brake unlocking screw(30) up to the end stop.

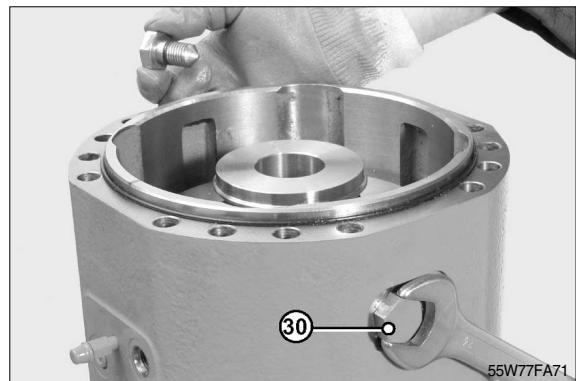

(40) Remove the two auxiliary screws.



(41) Exchange and lubricate the O-ring and insert the arm to the box.

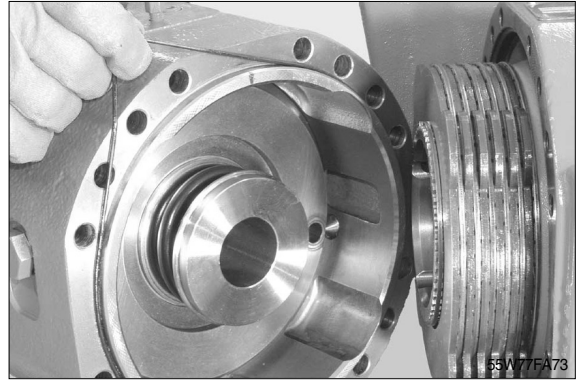

(42) Insert the screws and tighten them alternately.  
· Torque : 128N · m(91.5lbf · ft)

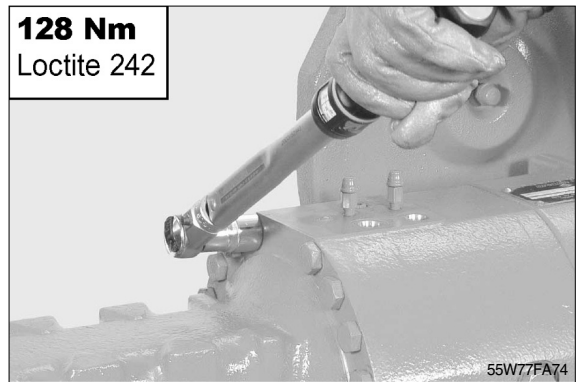

#### 4. DIFFERENTIAL : NORMAL PRELOADED DIFFERENTIAL

##### 1) Disassembly

- (1) Remove the brake side arm and the brake discs pack.  
Sling the arm to be removed and connect it to a hoist, remove screws of the crown wheel side arm.

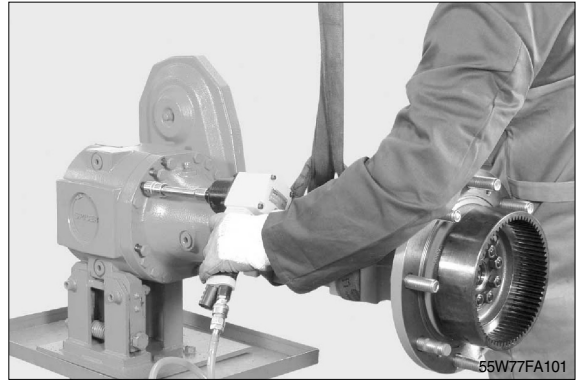

- (2) Remove the hydraulic block discs one after the other.

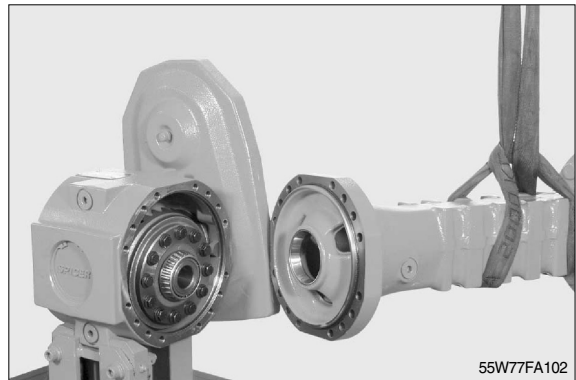

- (3) Position the differential gear sideways into the recess in order to be able to pull it out.  
※ Attention!

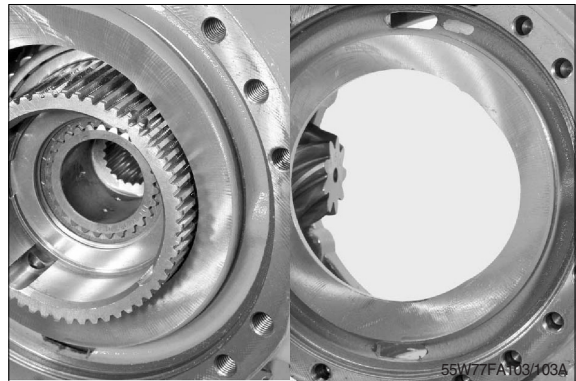

- (4) Pull out the differential.

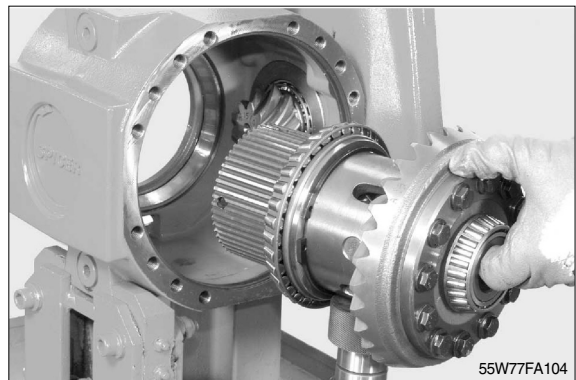

- (5) Remove the snap ring(22) that secures the thrust bearing.

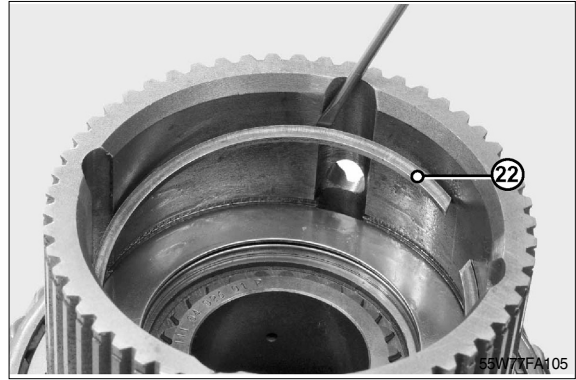

- (6) Remove the snap ring(22) and thrust bearing(23).

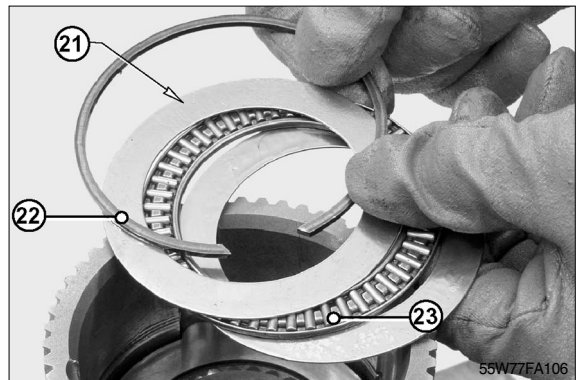

- (7) Remove the hydraulic block discs(20)(24) one after the other.

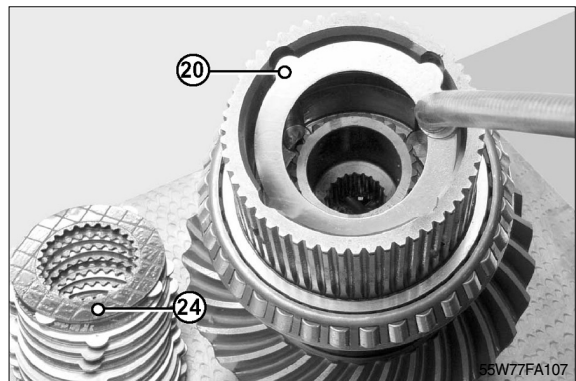

- (8) Remove the snap ring(19) that secures the planetary gear.

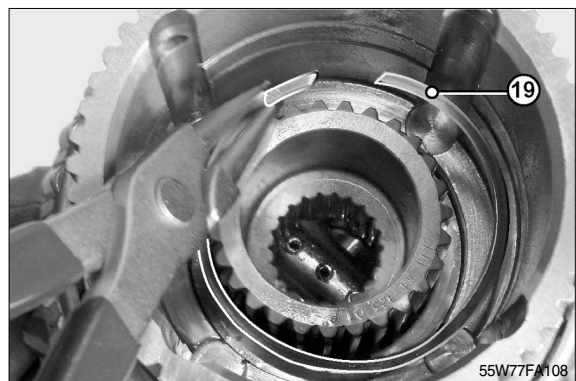

(9) Remove the brake side planetary gear.

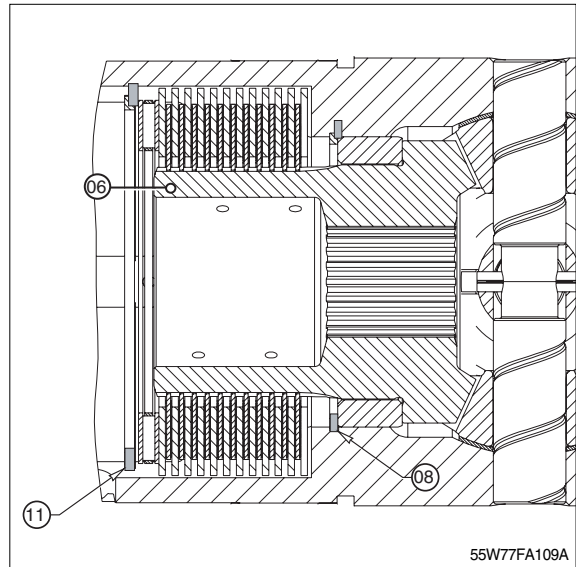
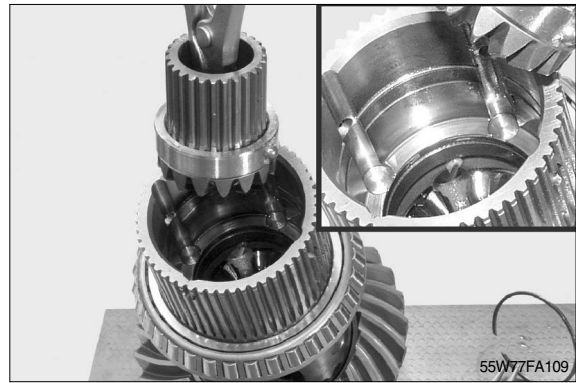

(10) Remove the snap ring(33) out of its seat by moving it sideways.

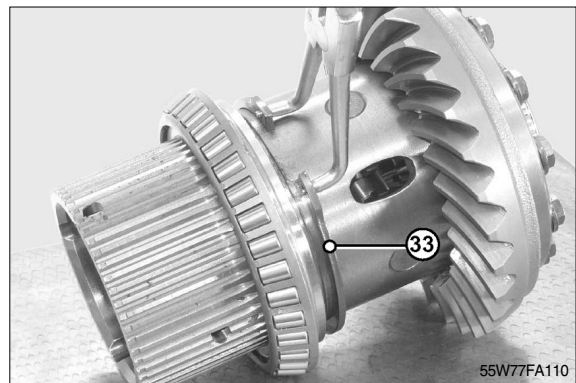

(11) Using a puller, extract the bearing(35) and the washer(34).

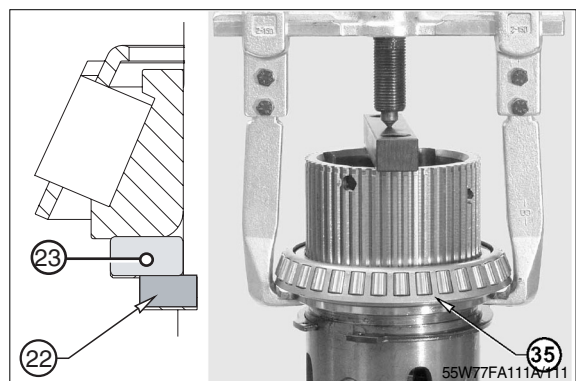

(12) Remove completely bearing(35), washer (34) and snap ring(33).

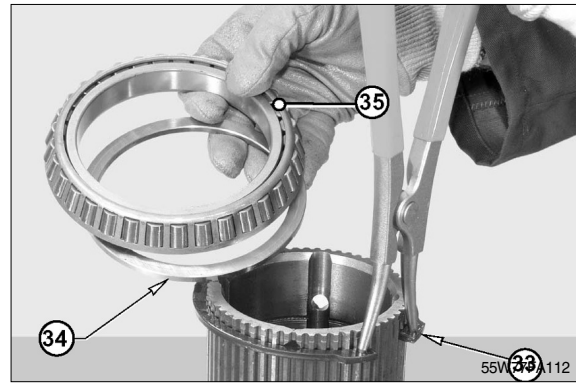

(13) Remove fixing screws(32) of the crown wheel(31); exchange each time when removed.

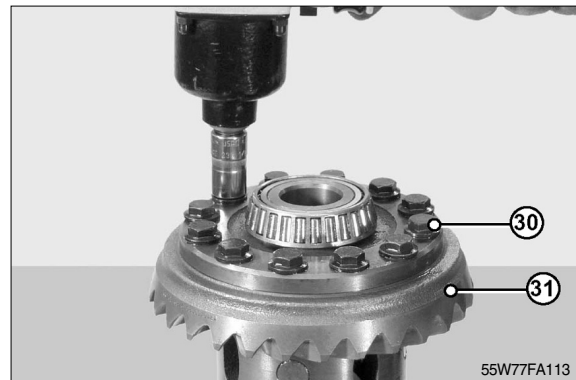

(14) Extract the crown wheel(4).

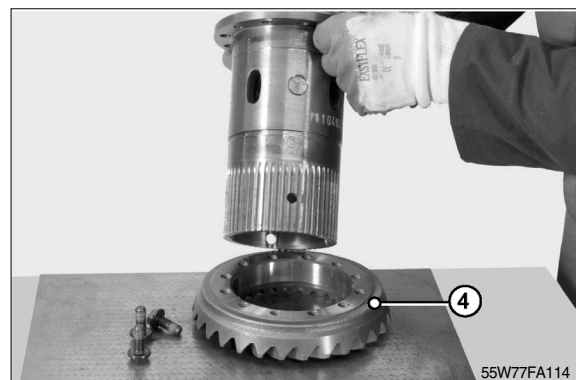

(15) Remove the tapered roller bearing(2) of the crown wheel side, using two levers.

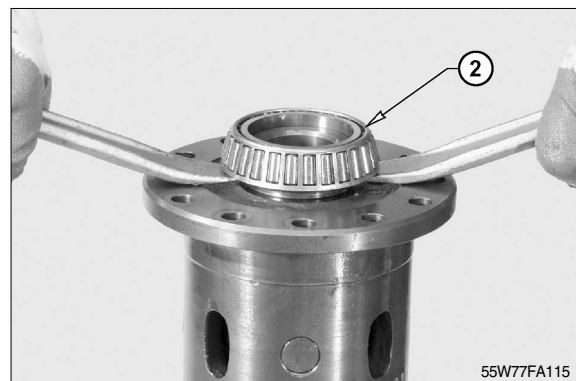

(16) Remove the three spider blocking pins(10) (13)(26)) by using a pin driver.

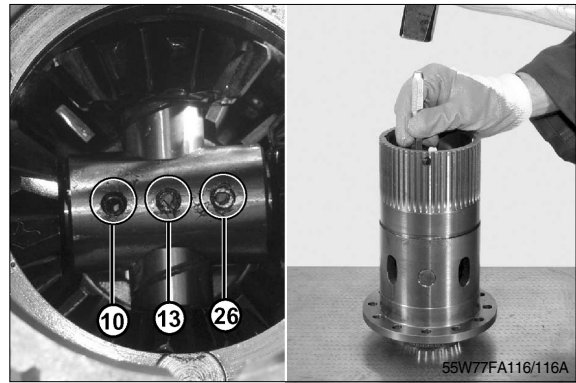

(17) Move the two opposite mounted short bolts(9)(28) to the outside of the box using the same pin driver.

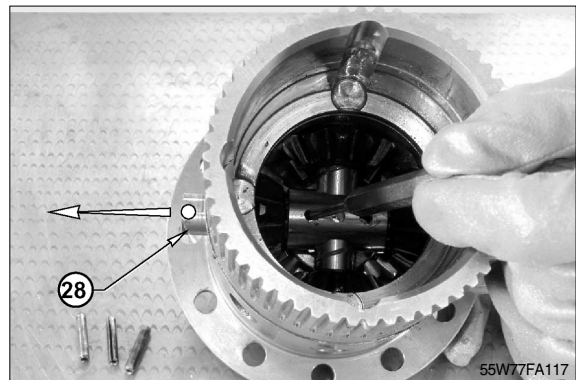

(18) Drive out the long bolt(14) and pull out the spider(16) from the centre.

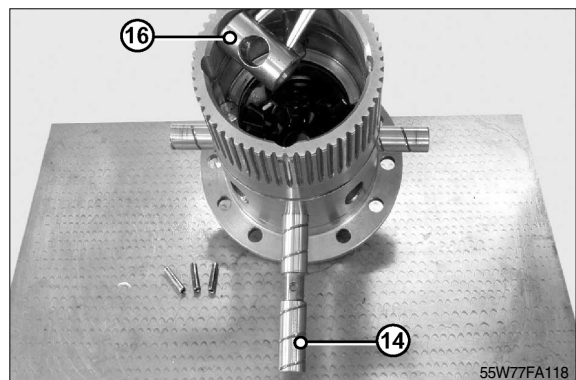

(19) Remove the two half bolts(9)(28), spherical washers(8)(28) and satellite wheels(27)(7).

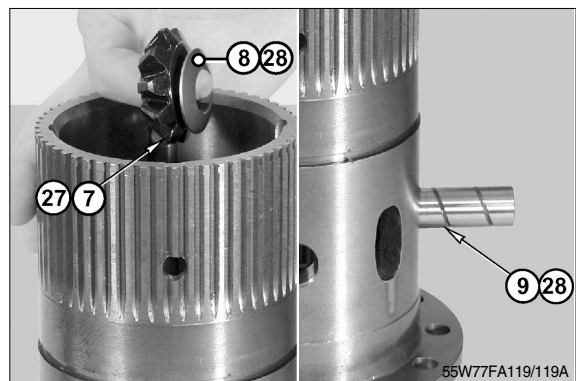

(20) Remove long bolt(14), spherical washers (12)(29) and satellite wheels(30)(11).

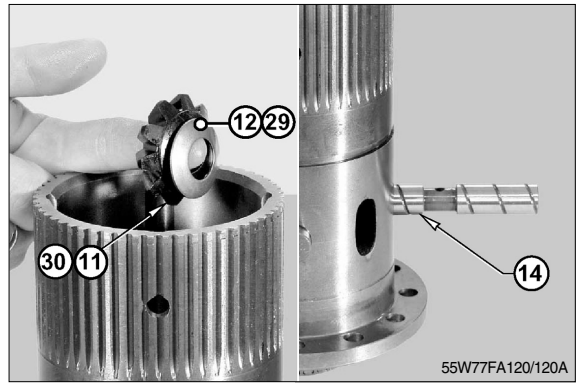

(21) Remove the planetary gear(6).

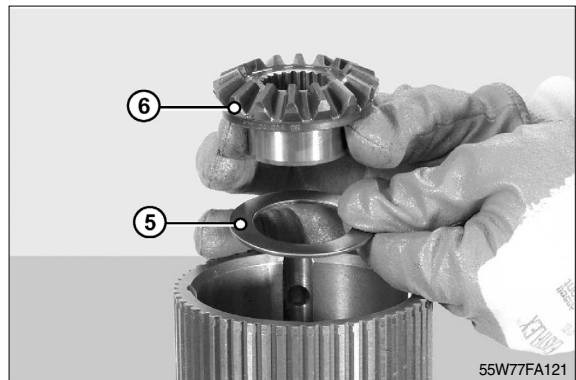

(22) Arrangement of the differential.

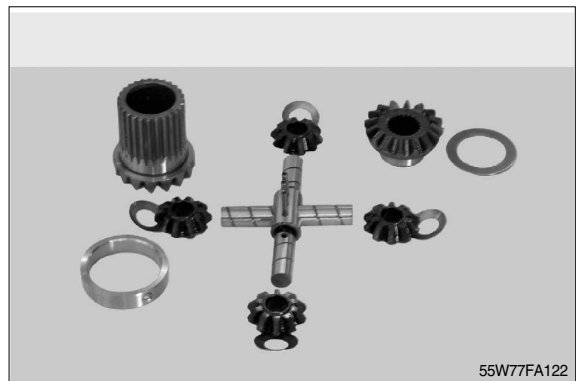

## 2) Assembly

(1) Differential module assembled



(2) Lubricate and insert washer and planetary wheel.



(3) Insert the two half bolts(28)(9), spherical washers(8)(28) and satellite wheels(7)(27).

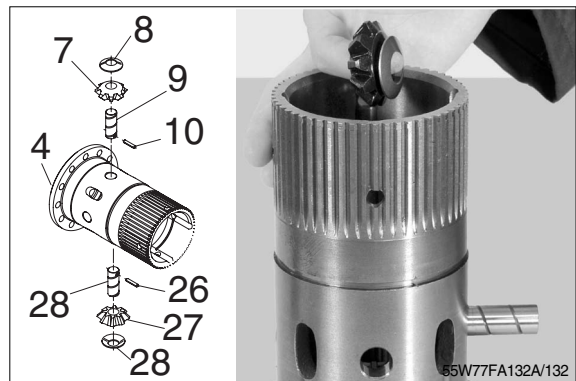

- (4) Partially insert the long bolt(14), satellite wheels(11)(30) and spherical washers(29) (12).

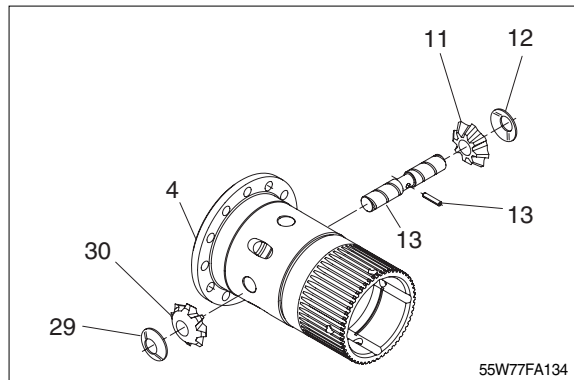
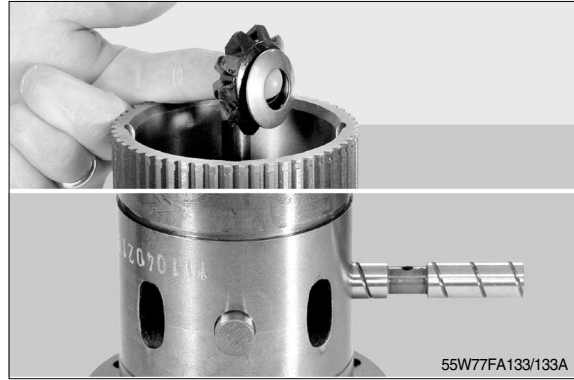

- (5) Insert spider(16) and completely insert the long bolt(14).



- (6) Insert completely the half bolts(9)(28).

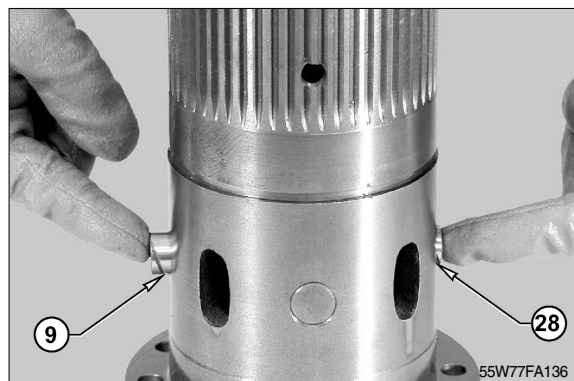

(7) Centre the pin holes and insert the 3 pins (10)(13)(26).

※ Check the free rotation of the satellite wheels on the bolts.

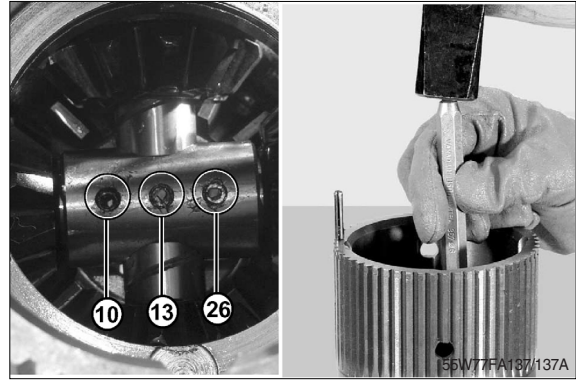

(8) Insert the planetary wheel together(17) with the centering sleeve(25).

※ The centering sleeve must have the fixing ball(18) assembled.

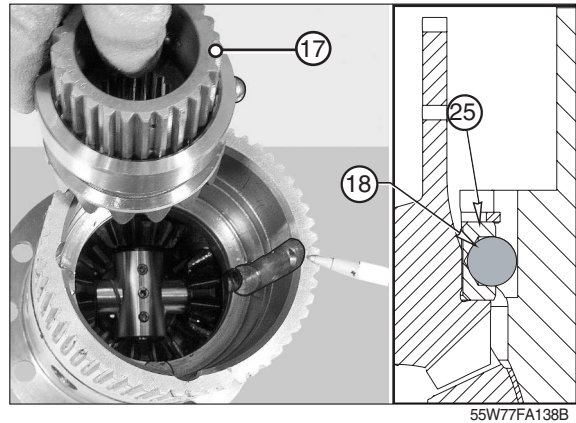

(9) Insert snap ring(22) of the planetary wheel.

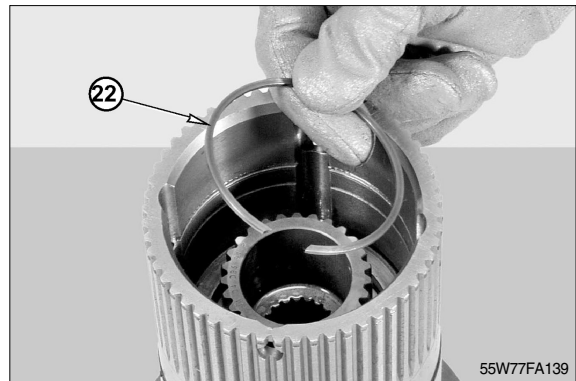

(10) Insert and substitute, if necessary, the discs(20)(24) of the differential lock.

※ First and fast disc have to be of steel.

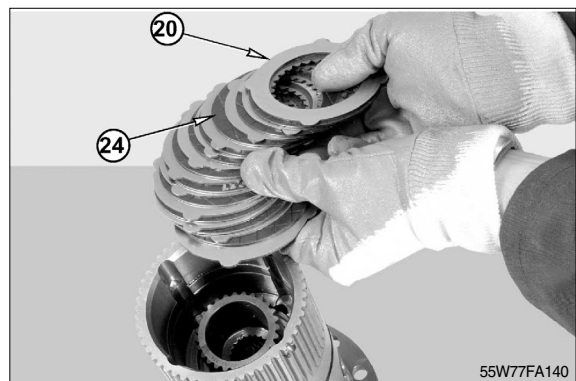

(11) Insert thrust bearing(23) and snap ring (22).

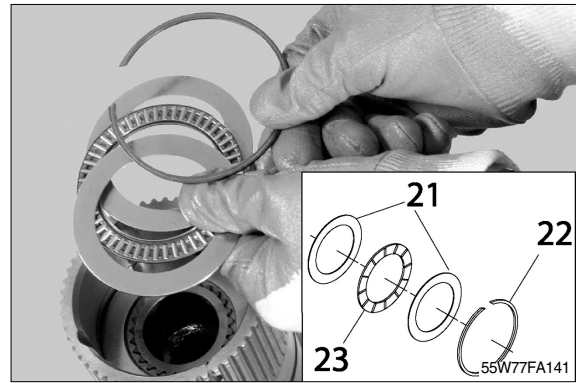

(12) Insert crown wheel(31).

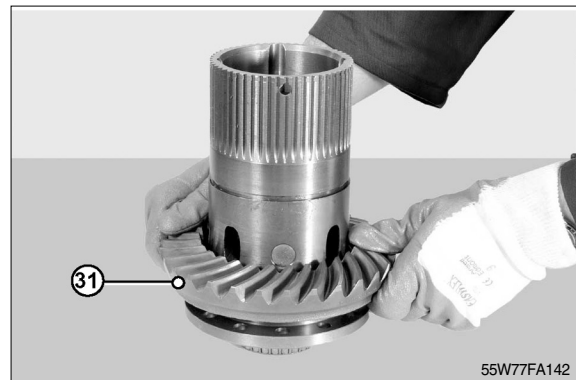

(13) Insert the screws(32).

Tighten screws with a torque wrench setting of 78~86N · m(57.5~63lbf · ft).

※ Always use new screws to fix the crown wheel. In case the screws are not thread locking pretreated, use loctite 270.



(14) Assemble the bearing(2).

※ Heat the bearing to 100° C before assembling.

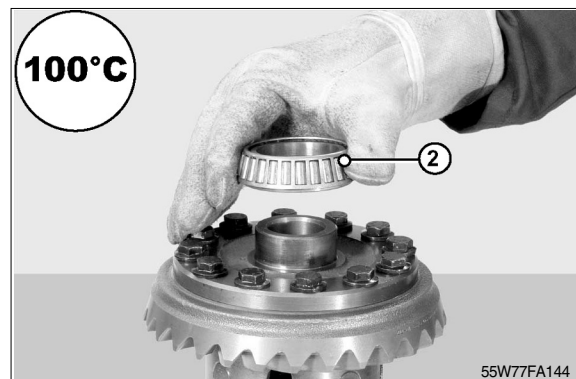

(15) Assemble the snap ring(33) in it's seat.

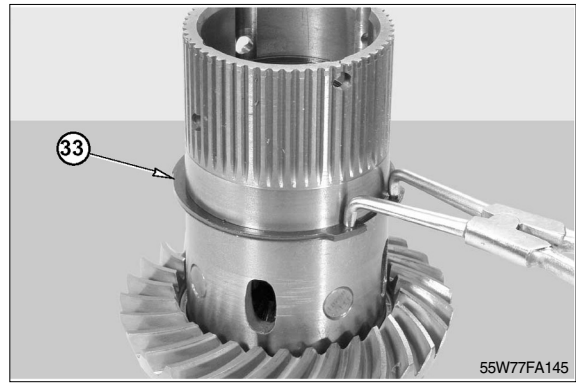

(16) Assemble shim(34) and bearing(35).

※ Heat the bearing as well as the shim to 100° C before assembling.



## 5. BEVEL PINION

### 1) Disassembly

(1) Make positional marks across nut(1) and pinion(11) tang;

If disassembly is awkward, heat the check nut(1) of the flange(2) at 80° C.

※ Heating is meant to unloose the setting of loctite on the nut(1).

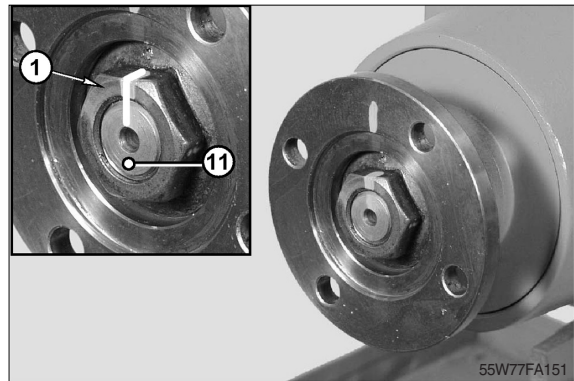

(2) Position tool T5, so as to avoid pinion rotation. Unloose and remove the nut(1); also remove the O-ring(6).

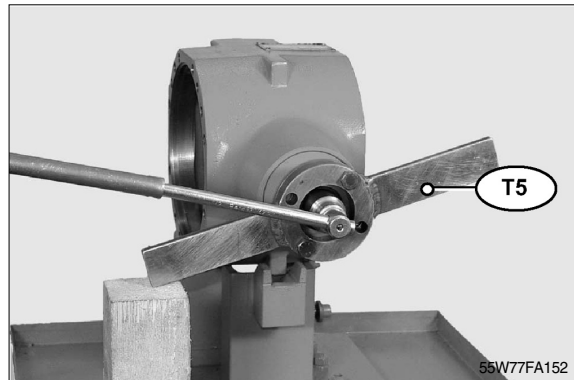

(3) Remove the flange(2) complete with guard(7) by means of a puller.

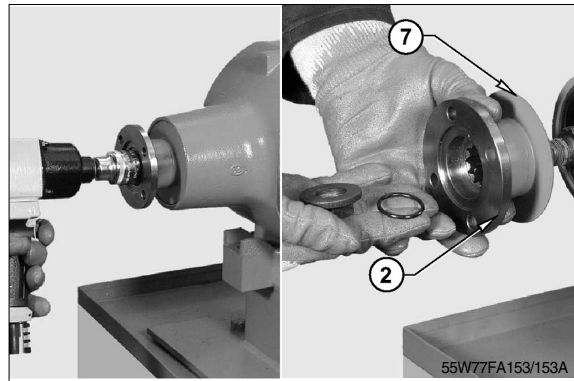

(4) Remove the sealing ring(3).

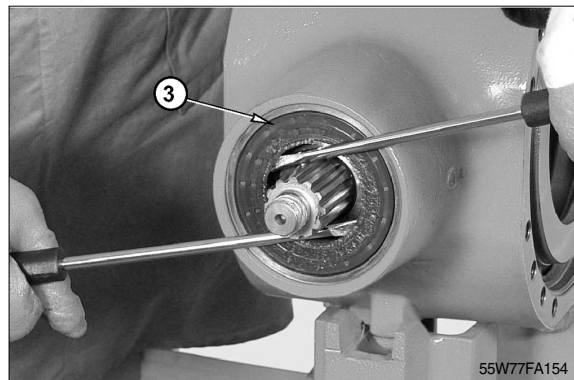

(5) Remove the sealing ring(3) and spacer (8A).

※ Sealing rings(3) must be replaced each time the unit is disassembled.

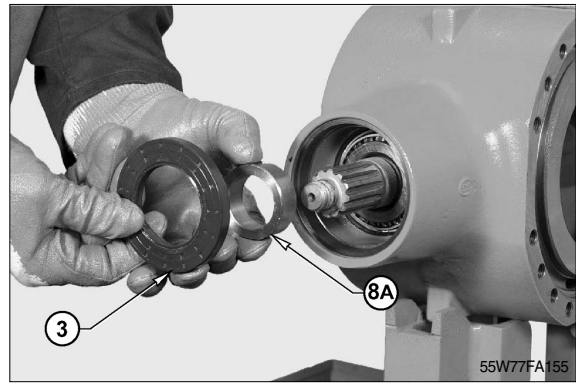

(6) Remove the pinion(11), shims and distance piece.

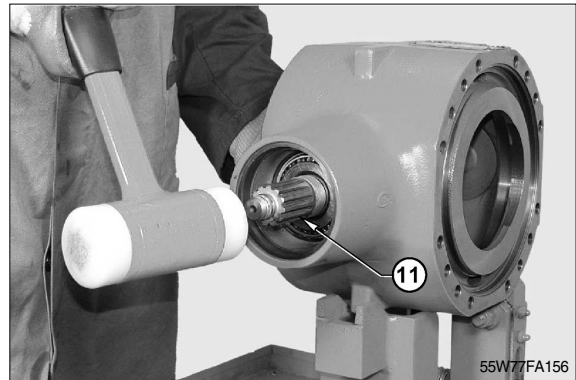

(7) Refer and keep to the positions marked during disassembly.

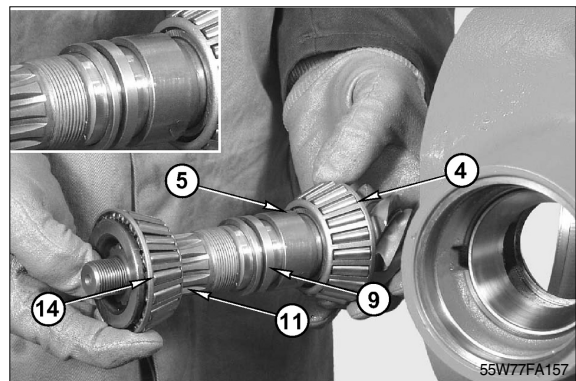

(8) Using a puller and a press, remove the inner bearing(4) from the pinion(11).

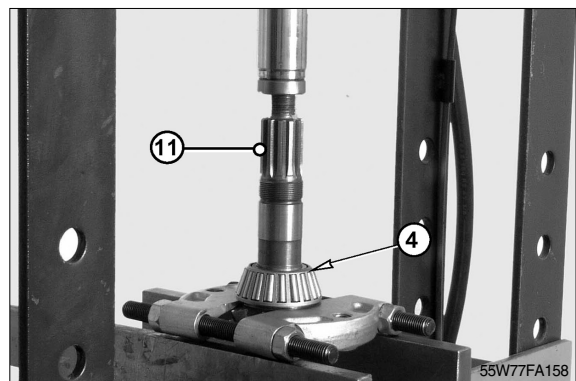

(9) Remove the thrust block of the external bearing(14).

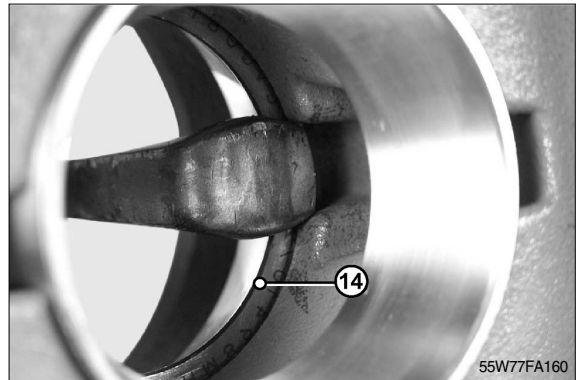

(10) Insert a drift in the appropriate holes.

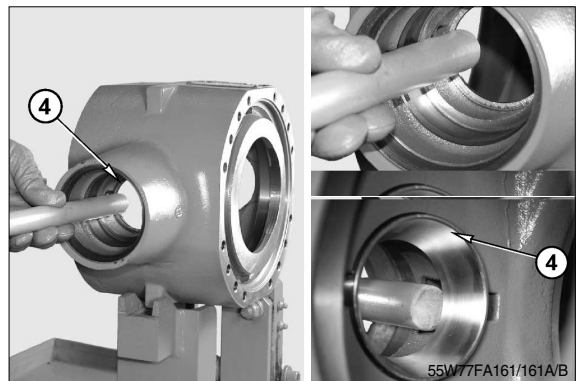

(11) Remove the thrust block of the internal bearing(4) as well as the shim washers (10)(S).



(12) Remove the snap ring(15).

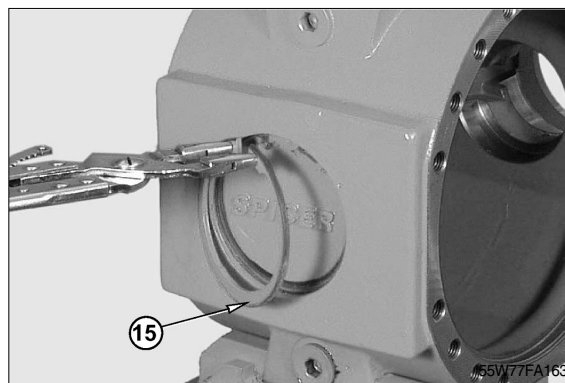

(13) Remove the cap(14).



## 2) Assembly

### (1) Calculating pinion centre distance

Using a faceplate, reset a centesimal comparator "DG" on a calibrated block (Whose known thickness is 30mm).  
Preload the comparator by about 3mm.

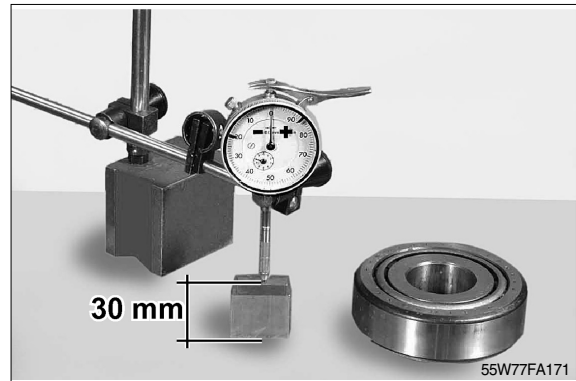

### (2) Bring inner bearing(4), complete with thrust block, under comparator "DG".

※ Press the thrust block centrally and carry out several measurements by rotating the thrust block.

(Example :  $30 - 0.55 = 29.45 = "D"$ )

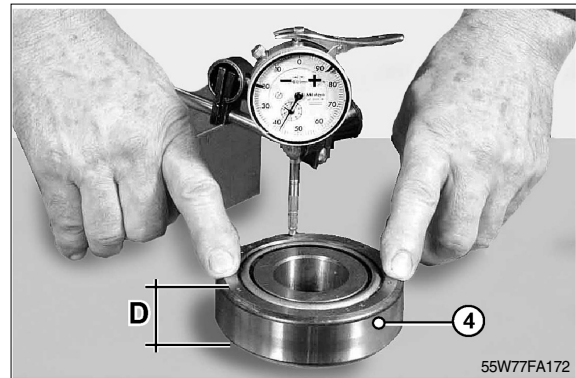

### (3) Check nominal dimension "l" as marked on the pinion. Add up to or subtract from "l" the variation indicated as "Y" to obtain the actual centre distance "l".

(Example :  $l = INT \pm Y = 98 - 0.1 = 97.9 \text{ mm}$ )

※ C61=Match part number

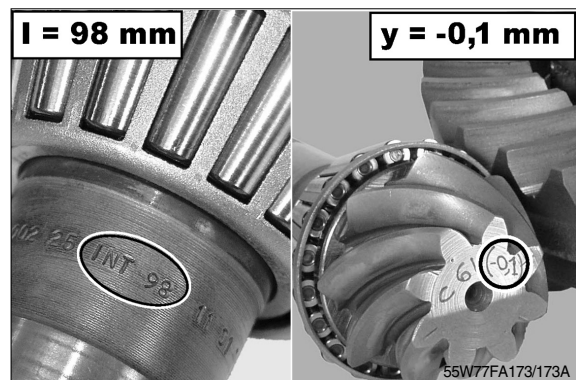

### (4) C61 = bevel gear set matching number (-0.1) = Y variation from the theoretical l=98

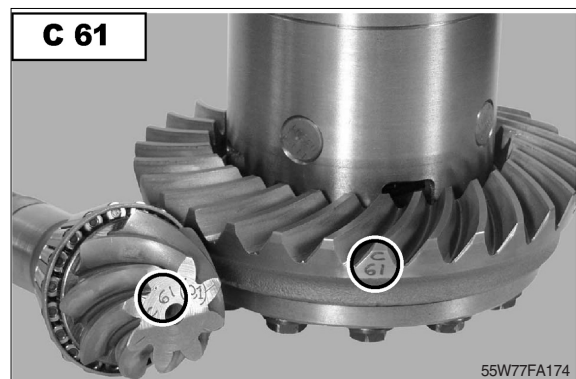

- (5) Calculate shims "S" for insertion under the thrust block of the inner bearing using the following formula:

$S = X - (I + D)$  where: X = fixed dimension

I = Actual pinion centre distance

D = Total bearing thickness;

(Example:  $S = 128 - (97.9 + 29.45) = 0.65\text{mm}$ )



- (6) Using special tool T8.  
Partially insert the thrust block of the bearings(4) and shims(10).

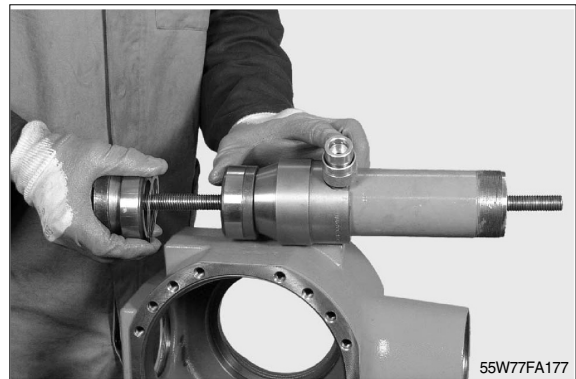
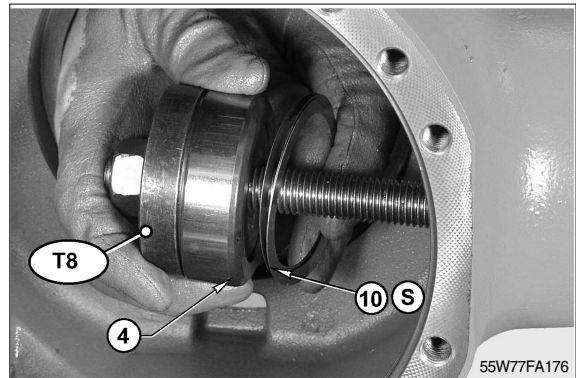

- (7) Connect the tension rod to the press and move the thrust block of bearings(4)(14) into the seats.

Disconnect the press and remove the tension rod.

- ※ Before starting the next stage, make sure that the thrust block has been completely inserted into its seat.

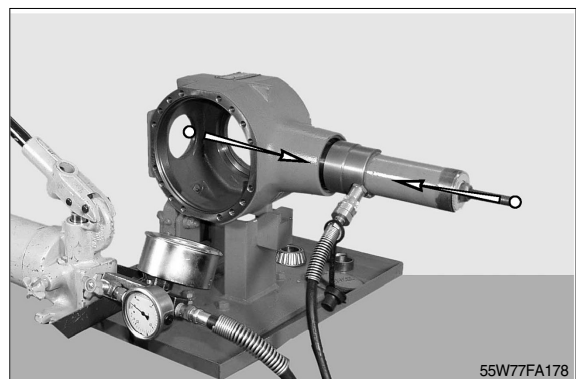

**(8) Calculating pinion bearings rolling torque**

Introduce tool T9 complete with bearings (4) and (14) into the main body(12); tighten by hand until a rolling torque is definitely obtained.

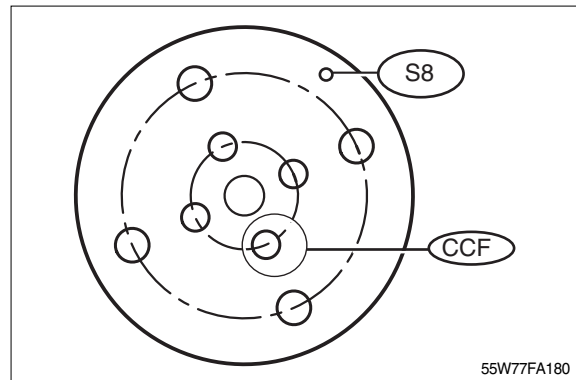
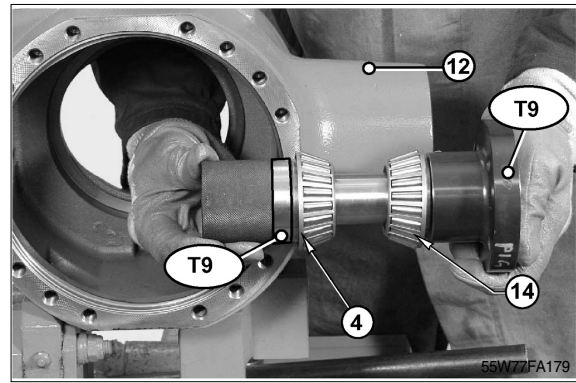

**(9) Introduce the tracer of a depth comparator "DDG" into either side hole of tool T9.**

Reset the comparator with a preload of about 3mm.

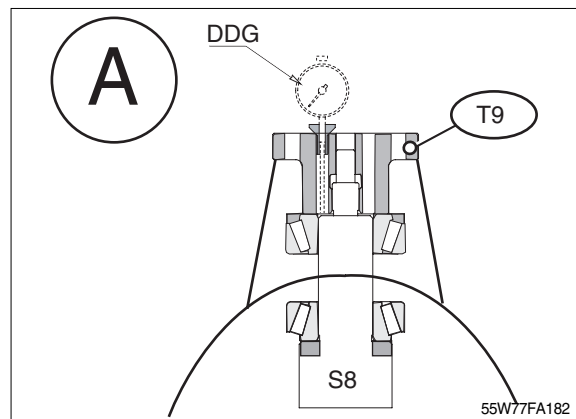
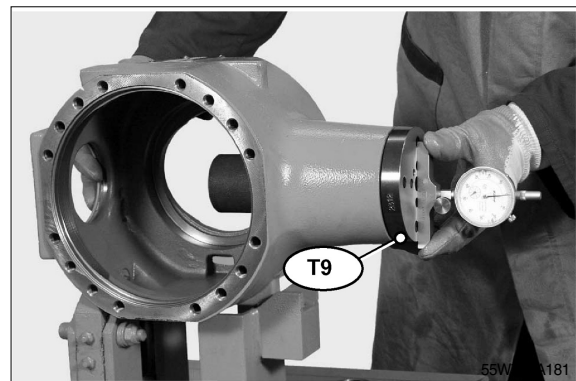

- (10) Remove the comparator and take out tool and bearing kits from the main body. Reinstall every part, also introducing a distance piece between bearings(4) and (14). Tighten the entire pack by hand.

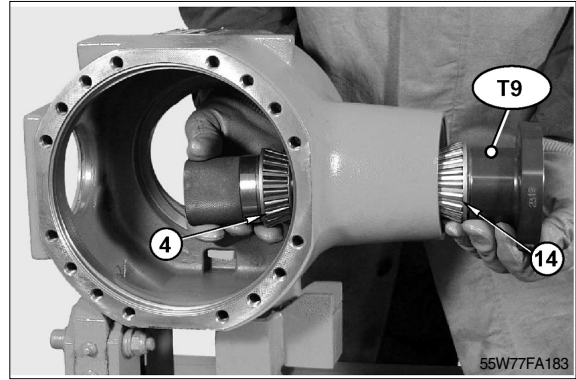

- (11) Assemble on top of the tool T9 and between the two bearings the shim(5) and the largest calibrated shim(9).



- (12) Measure the difference H using a dial gauge DDG  
E.g.  $H = A - B = 2.93\text{mm}$

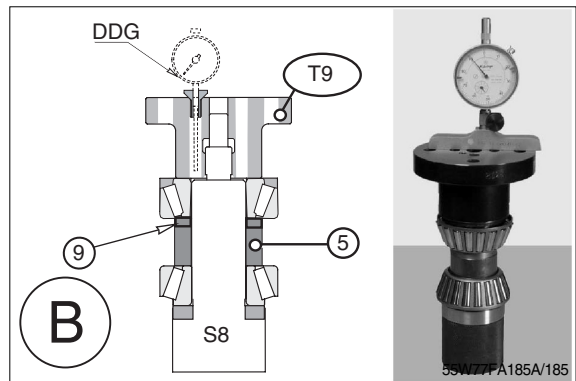

- (13) Calculate the shim S2 to be inserted.  
E.g.  $S2 = H + X = 3.01\text{mm}$  where X = fixed value to obtain  $= 0.07 \dots 0.08\text{mm}$



(14) Heat the bearing(4) to a temperature of about 100°C and fit it on to the pinion(11).

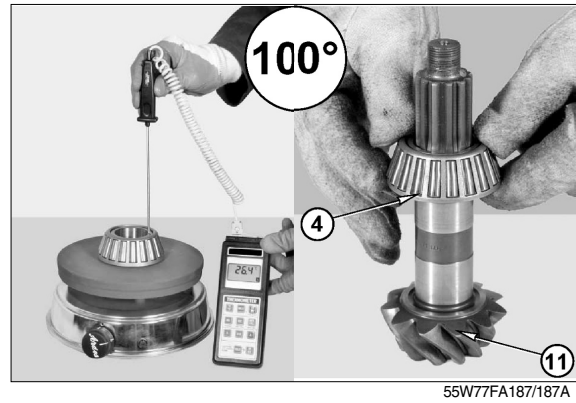

(15) Fit the pinion(11), shim "S1"(10) and distance piece(5)(9) in the main body(12).  
※ The finer shims must be placed in-between the thicker ones.

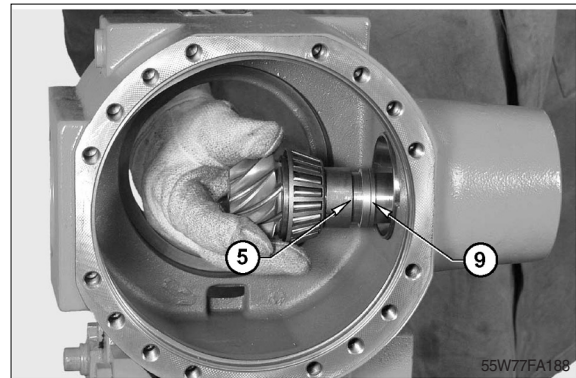

(16) Heat the external bearing(14) to a temperature of about 100°C and fit it on to the pinion(11) so as to complete the pack as shown in the figure.

※ Lightly lubricate bearing with SAE85 W90 oil.

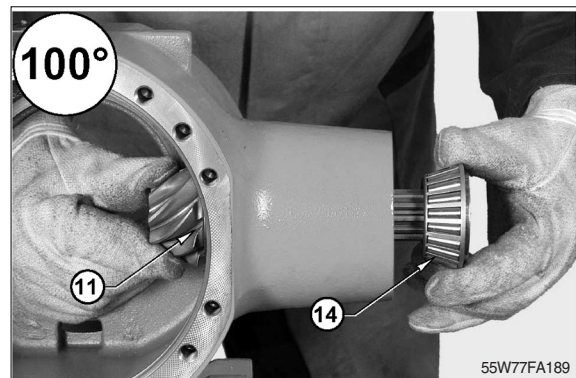

(17) Insert the spacer(8A)

※ Check the using of the friction washers, if.

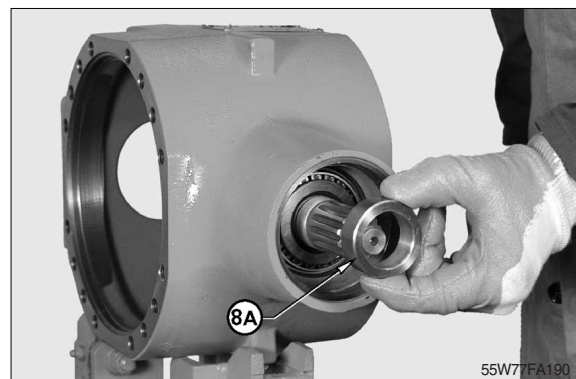

(18) Install the flange(2) onto the pinion(11) without sealing ring.

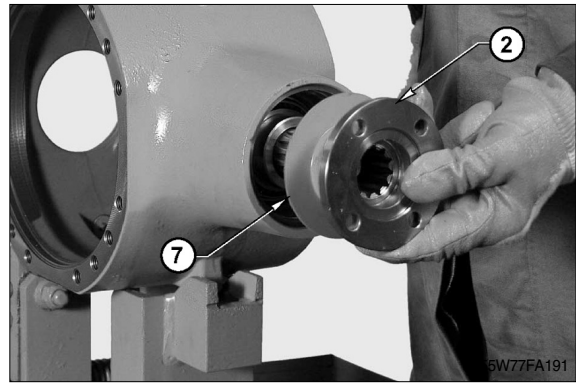

(19) Install the nut(1) without LOCTITE 270.

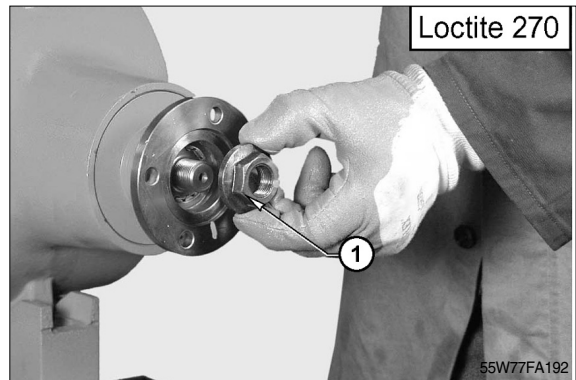

(20) Lock the wrench T5, rotate the pinion using a dynamometric wrench, up to a minimum required torque setting of 260~300Nm(191.7~221.2lbf · ft).

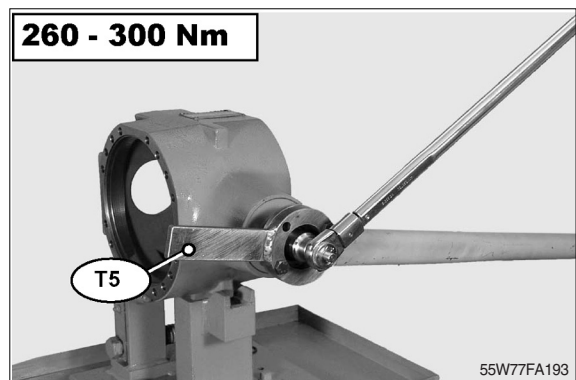

(21) Apply onto the pinion(1) the bar-hold and with the help of a torque metre, check the torque of the pinion(1).

Torque : 80~120Ncm(0.6~0.9lbf · ft)

▲ If torque exceeds the maximum value, then the size of shim "S1"(4) between the bearing(9) and the distance piece(3) needs to be increased.

If torque does not reach the set value, increase the torque setting of the ring nut(10) in different stages to obtain a maximum value of 500Ncm(368.8lbf · ft)

▲ If torque does not reach the minimum value, then the size of shim "S1"(4) needs to be reduced.

▲ When calculating the increase or decrease in size of shim "S1", bear in mind that a variation of shim of 0.01mm corresponds to a variation of 60Ncm(0.44lbf · ft) in the torque of the pinion(1).

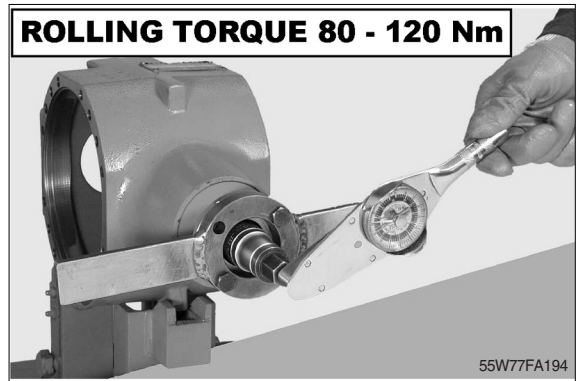

(22) Make positional marks across nut(1) and pinion(11) tang; then remove nut and flange(2)

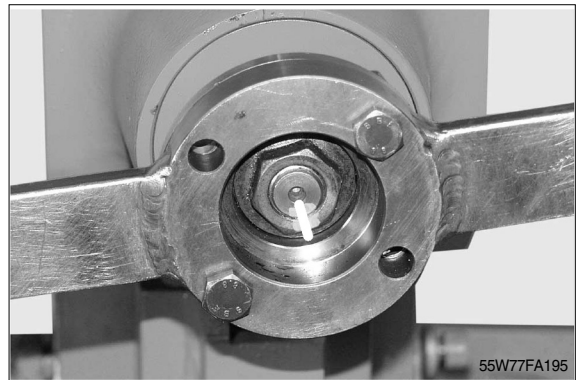

(23) Apply arexons rubber cement to the outer surface of the new seal ring(3) and fit ring in the main body(12) using driver T11.

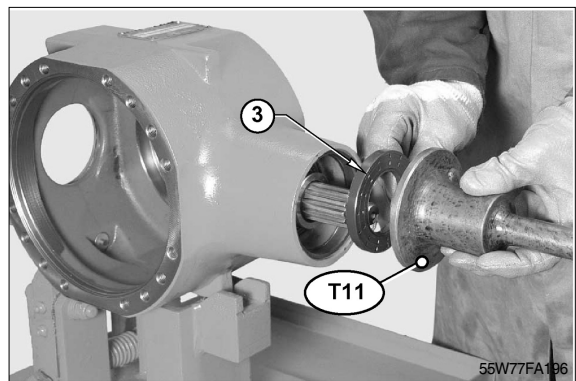

- (24) Oil seal ring lips and install flange(2).  
Mount O-ring(6) and apply loctite 270 to pinion tang; tighten nut(1).

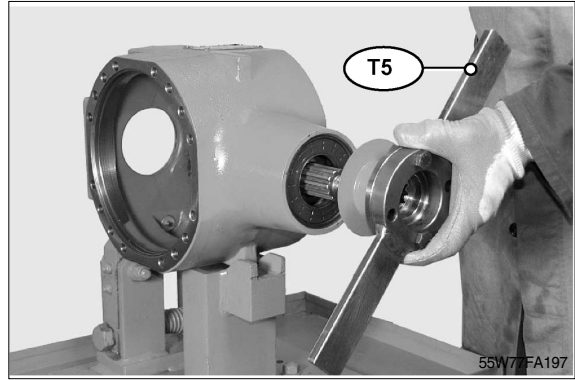

- (25) Tighten the nut until the match marks made at stage "A" line up.

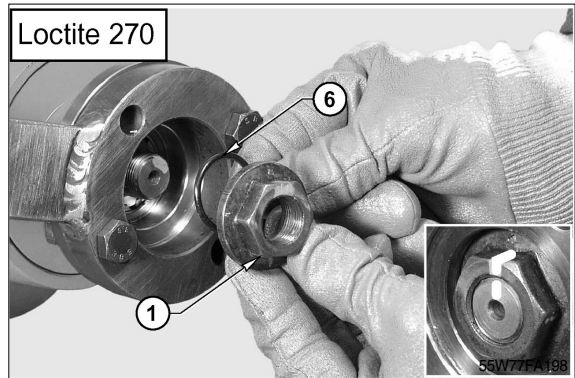

## 6. RING AND PINION ADJUSTING

### 1) Step for preloaded differential

- (1) Choose a pack of shims  $S_b$  with an initial value of about 0.37mm to place under the brake side bearing's cup.

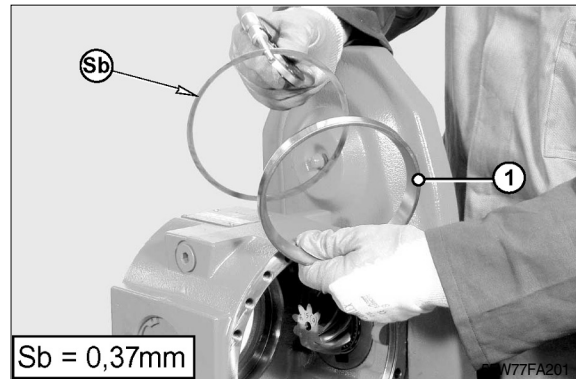

- (2) Assemble the shims  $S_b$ , the cup(1) and level.

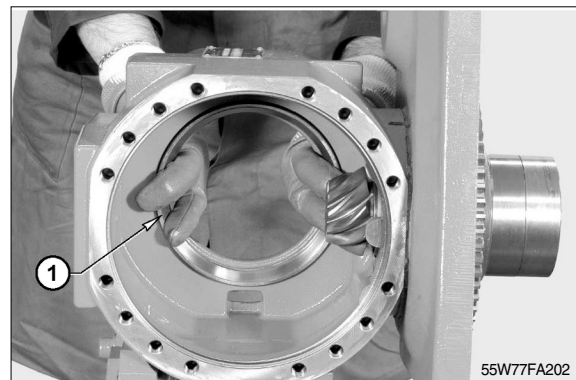

- (3) Remove the snap ring.

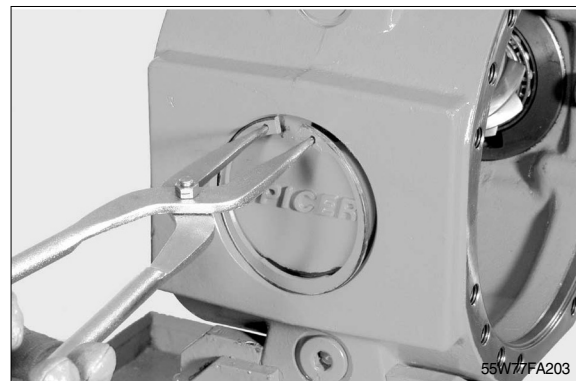

- (4) Remove cap.  
※ Do not bend the cap

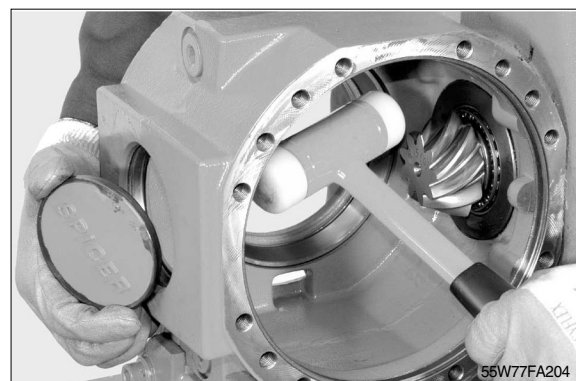

- (5) Insert the complete differential.  
※ Attention do not damage the sealing surface of the O-ring.

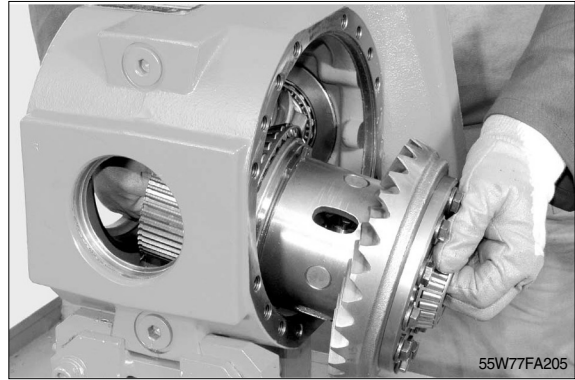

- (6) Choose a pack of shims Sc with an initial value of about 0.84mm to place under the crown wheel side bearing's cup.

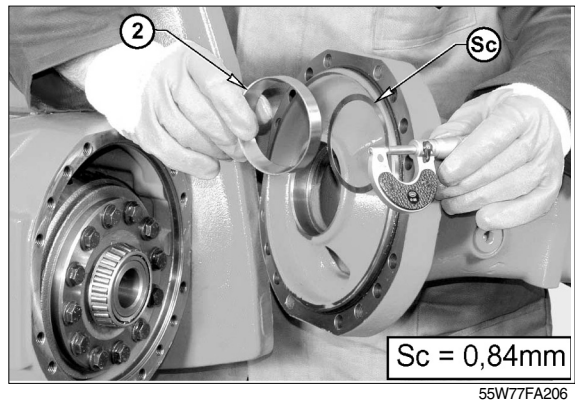

- (7) Assemble the shims Sc, the cup(1) and level.



- (8) Exchange always the O-ring of the arm.



- (9) Position comparator on the centre of one of the crown teeth, preset it to 1mm and reset it to zero. Manually move the crown in both directions to check the existing clearance between pinion and crown.

**(Gap = 0.13-0.20mm)**

In order to increase the gap while keeping the load on the bearing unchanged, take off shims from the crown wheel side and insert them on the opposite side. In order to decrease the gap, act the other way round. Introduce a comparator with rotary key through the rear cap hole.

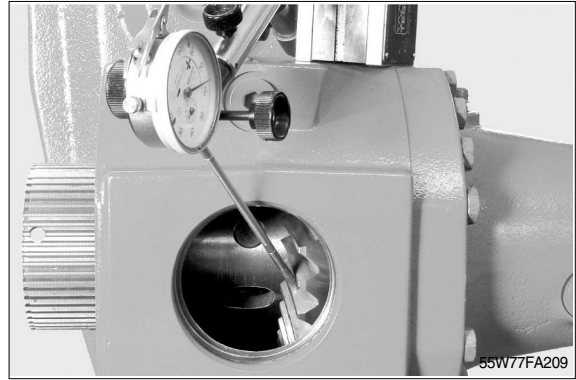

- (10) Assemble rubber cap and snap ring.

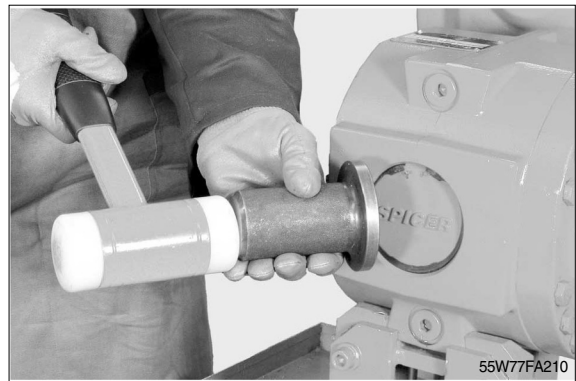

## 7. PLANETARY REDUCTION AND THE COMPLETE STEERING CASE

### 1) Disassemble

- (1) Remove the securing screws(23) from the planetary carrier cover(25).  
Disconnect the steering bars from the steering case(14).

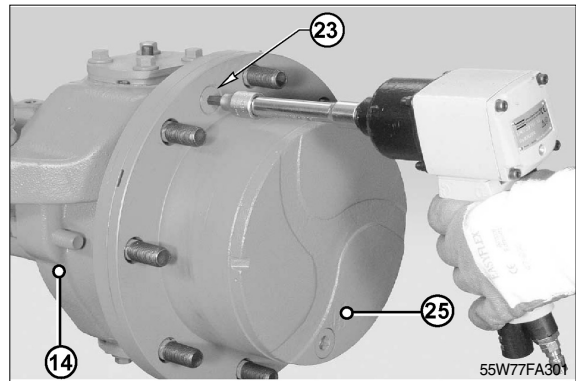

- (2) Disjoint the planetary carrier cover(25) from the steering case by alternatively forcing a screwdriver into the appropriate slots.

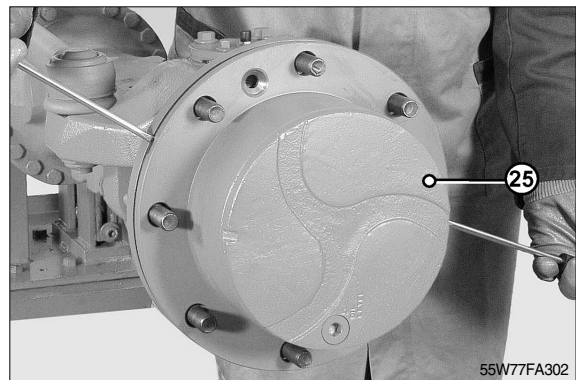

- (3) Remove the complete planetary carrier cover(25).

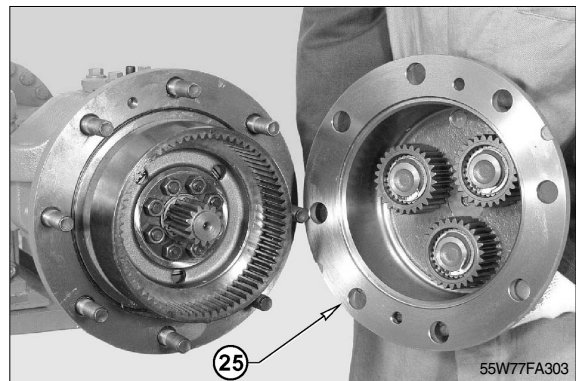

- (4) Remove snap ring(1).

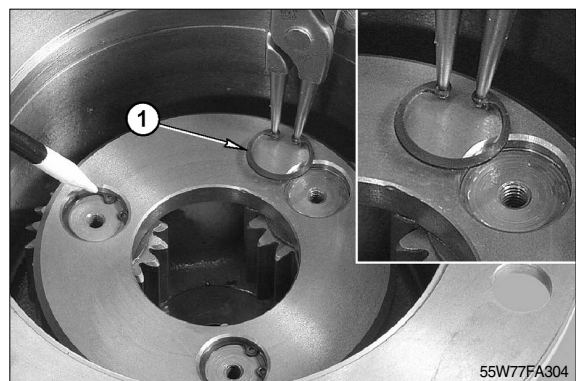

(5) Using a screw M6 remove all bolts(2).

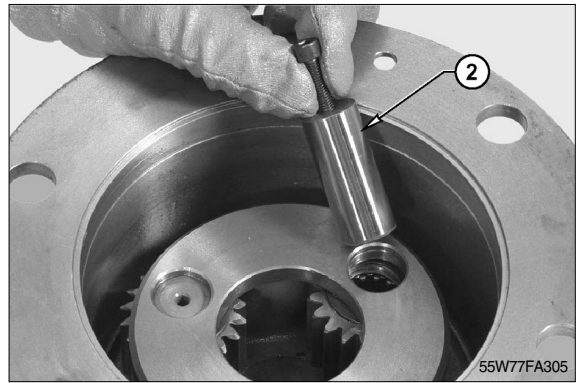

(6) Positioning the planet wheel gear(3) in center of the spider cover and remove.

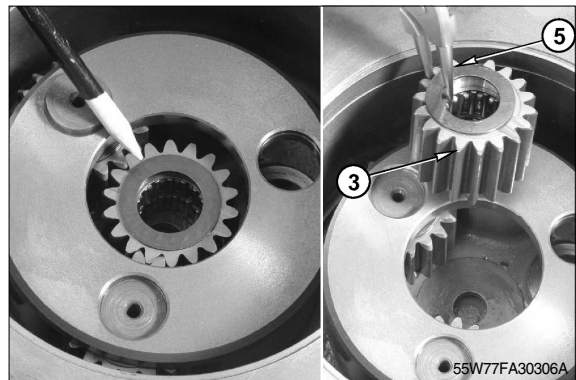

(7) Remove the snap ring(30).

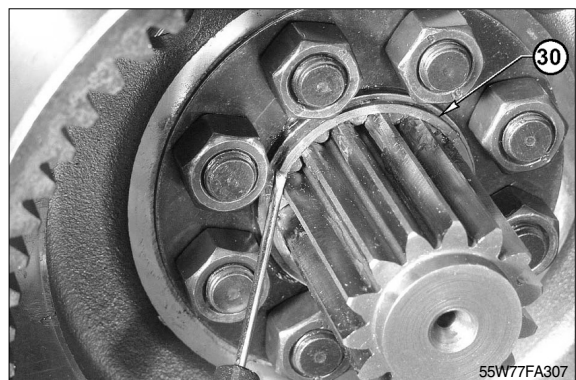

(8) Unloose and remove the tightening nuts (32) from the crown flange(35).

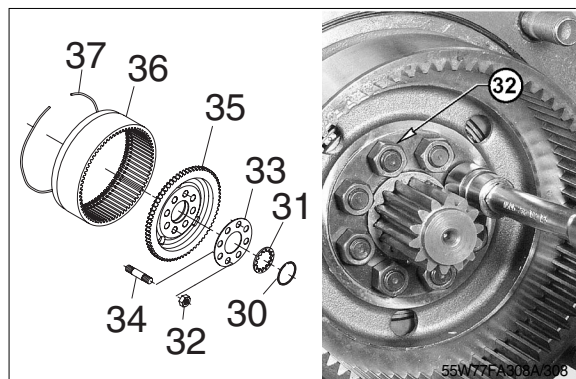

(9) Remove the shim washer(31).

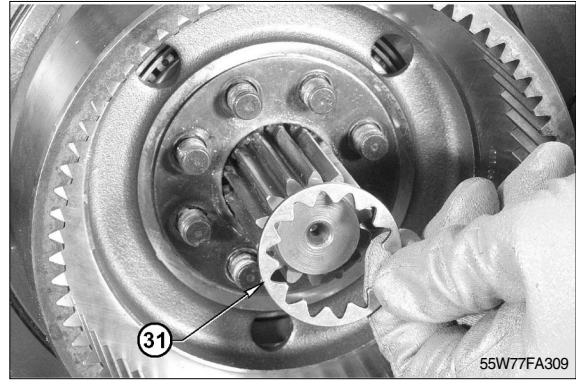

(10) Remove the safety flange(33).

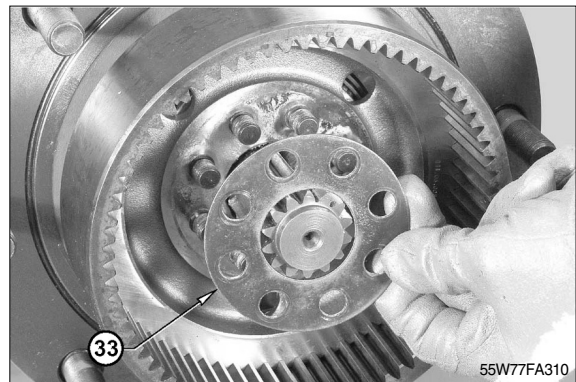

(11) Using a puller, remove the complete crown flange(35) by acting on the stud bolts.

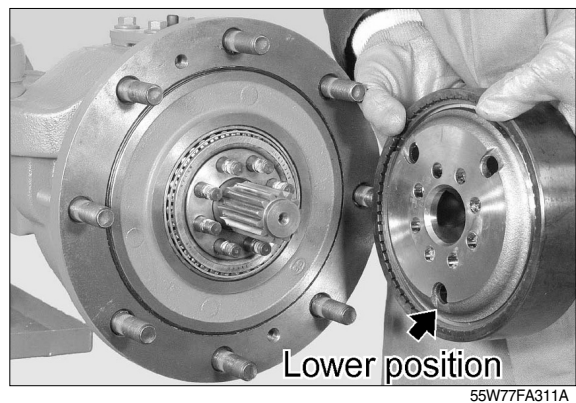
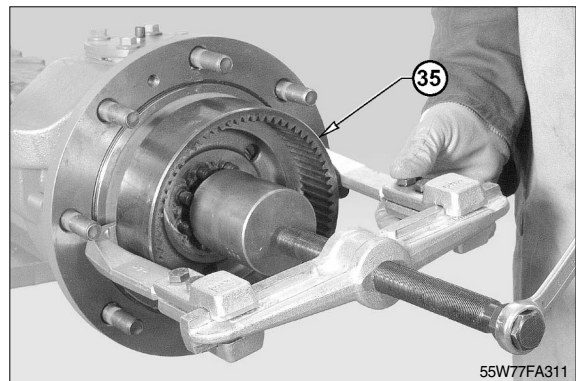

(12) Partially extract the hub(41) using a plastic hammer.

- ※ Alternately hammer on several equidistant points.

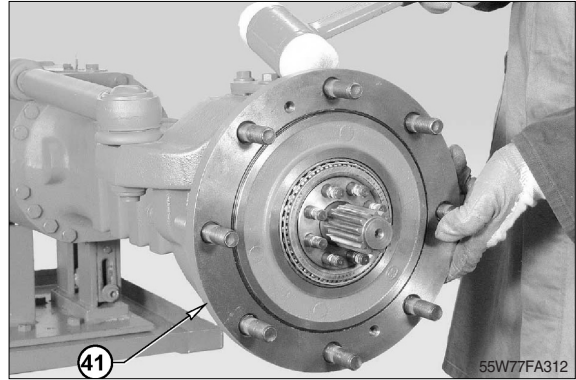

(13) Remove the external bearing(38).

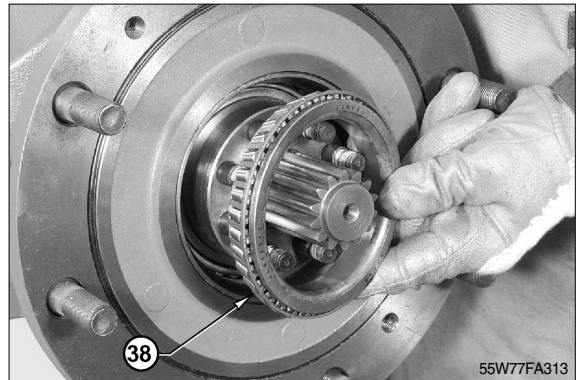

(14) By hand remove the complete hub(41).

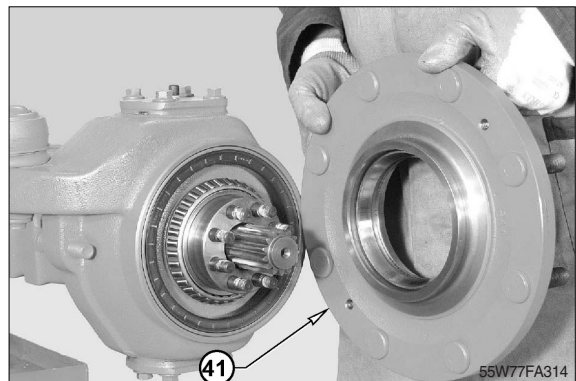

(15) Remove the external thrust blocks of bearings, using a pindriver.

- ※ Hammer in an alternate sequence to prevent crawling and deformation of the thrust blocks.

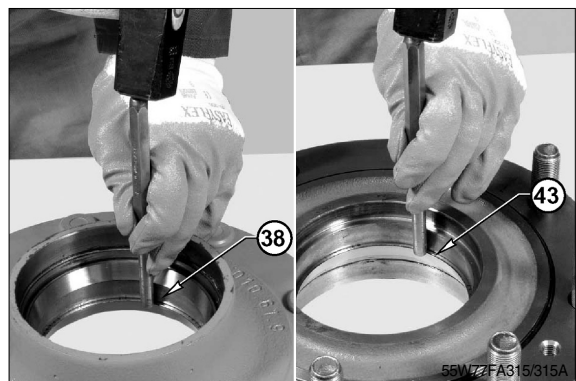

(16) Remove the sealing ring from the steering case(44).

※ Pay due attention not to damage the seat of bearing.

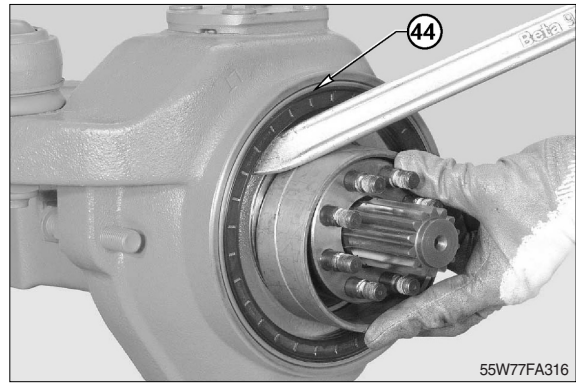

(17) Note the measure of the screw of lock steering case.

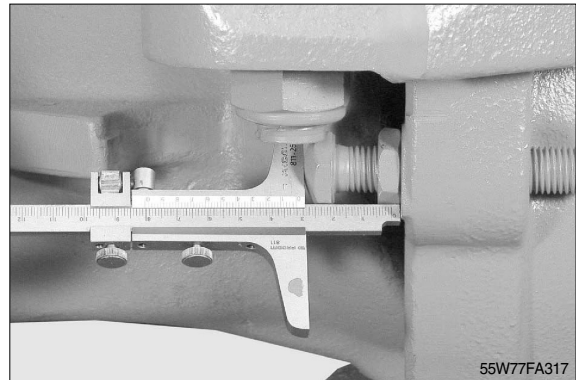

(18) Loose the lockscrew and insert it to allow the passage of tool.

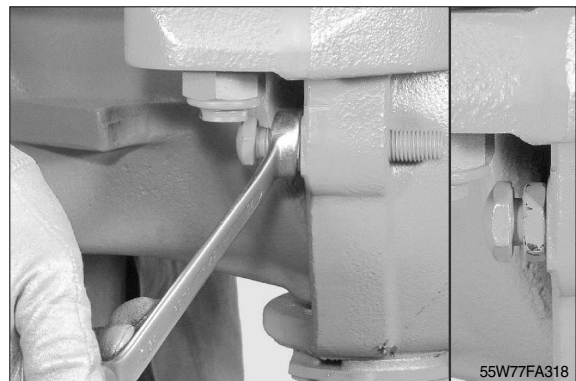

(19) Remove the nuts that lock the articulation pins.

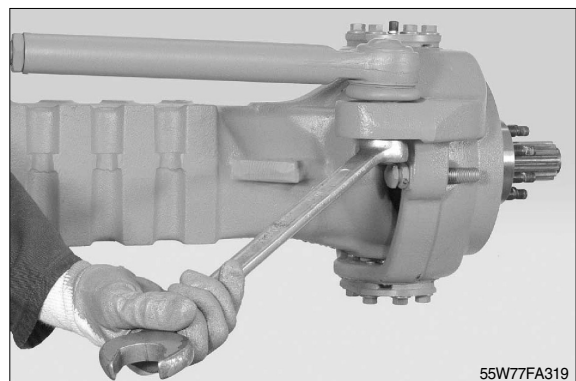

(20) Disconnect the tapered pins of the articulation from the steering case(14) by means of a puller.

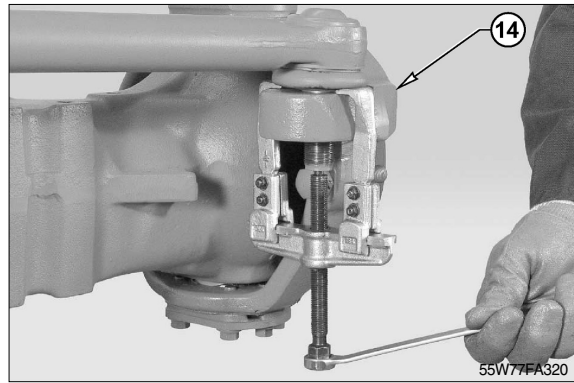

(21) Unloose and remove the fitting screws(19) from the bottom articulation pin(20).  
※ Screws cannot be re-used.

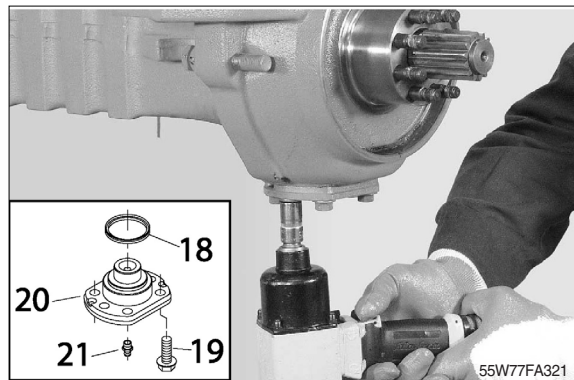

(22) Remove the bottom articulation pin(20) complete with front sealing ring(18).

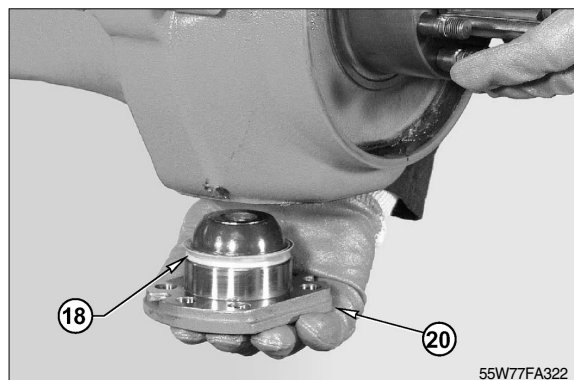

(23) Unloose and remove the fitting screws(13) from the top articulation pin(10).

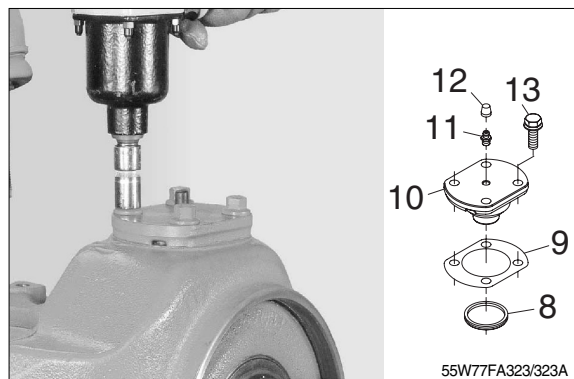

(24) Using two levers, remove the top articulation pin(10) complete with front seal(8).

※ Pay attention not to damage the surfaces.

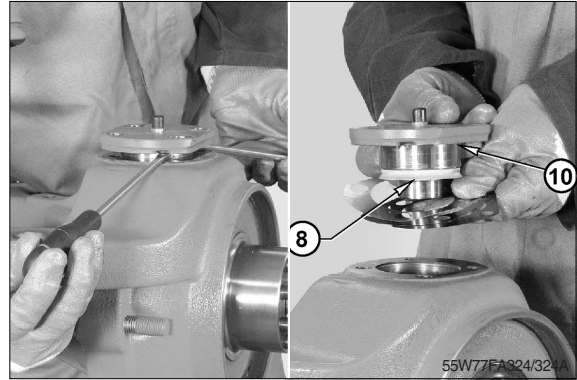

(25) Remove the complete steering case(14).

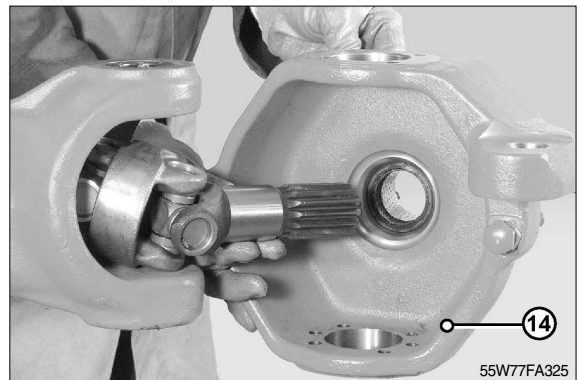

(26) Use a puller to remove the sealing ring from the steering case(14).

※ Note down the orientation of sealing ring (5).

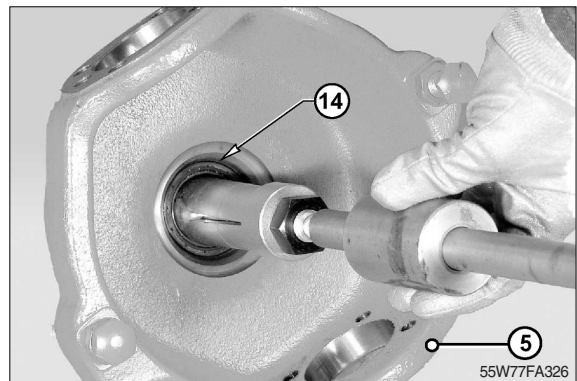

(27) Remove the bushing(6) from the steering case(14).

※ Note down the orientation of bushing.

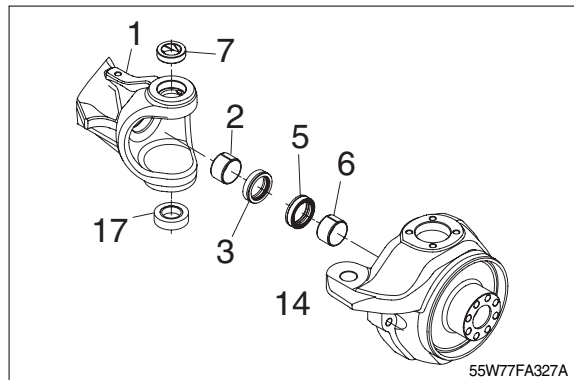
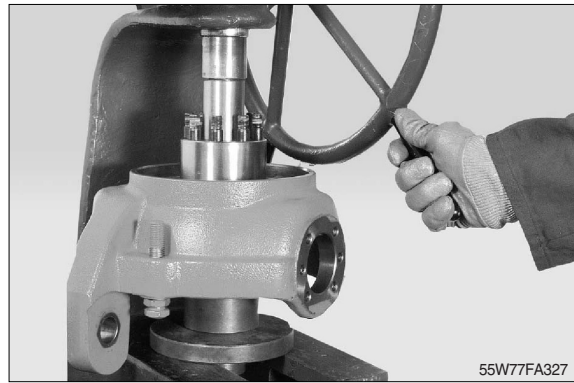

(28) Remove the u-joint(4).

※ To remove the u-joint use, if necessary, a plastic hammer or a lever.

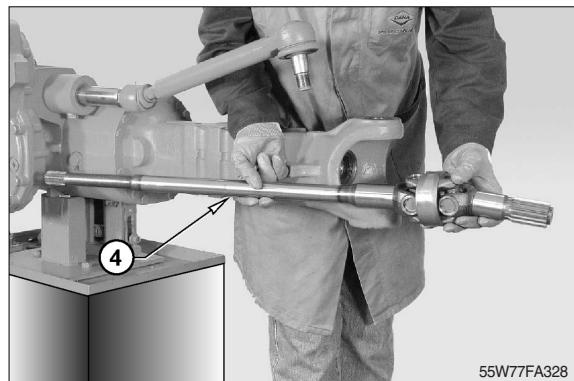

(29) Using a puller for inner parts, remove the top bush(7) and the bottom ball-bush(17).

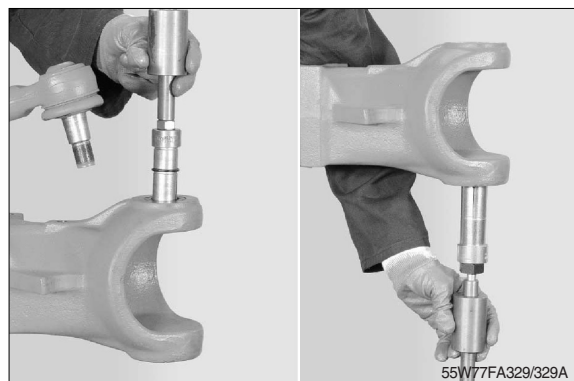

- (30) Remove the articulation pins(10)(20) and the front sealing rings(8)(18).  
※ Note down the side for assembly.

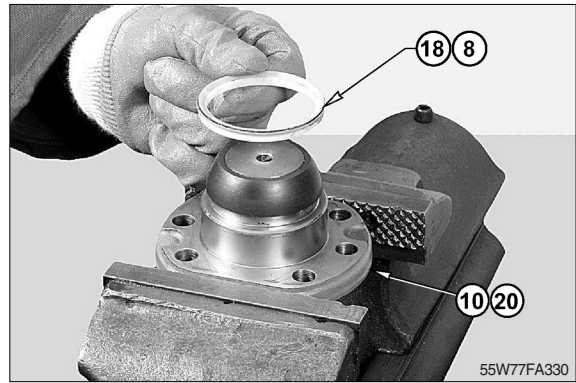

- (31) If the ball cover(17) needs replacing, remove it from the bottom articulation pin (20).

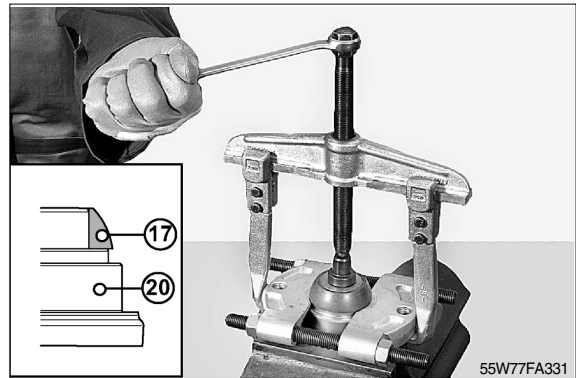

- (32) Remove seal ring(3) and the bushing(2) from the arm(1).

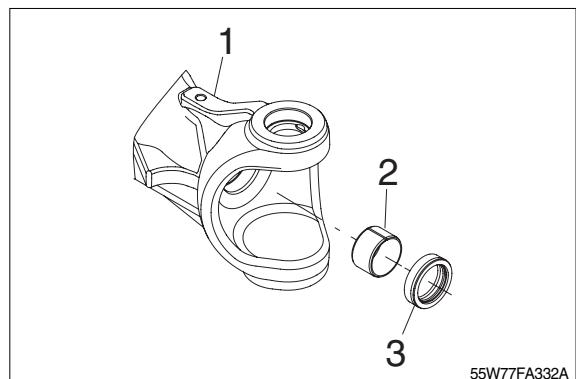

## 2) Assembly

- (1) Lubricate the bushing(6) and the seat of the steering case(14).  
Install the bushing(6), using tool T13.

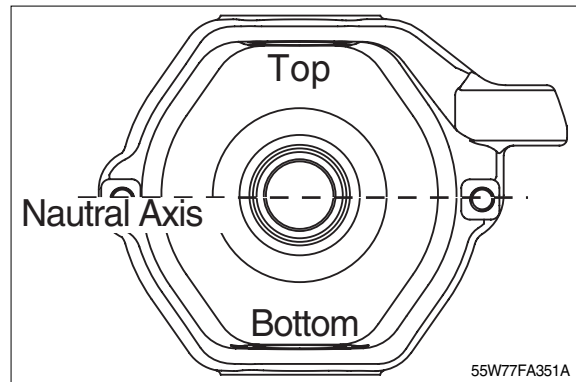
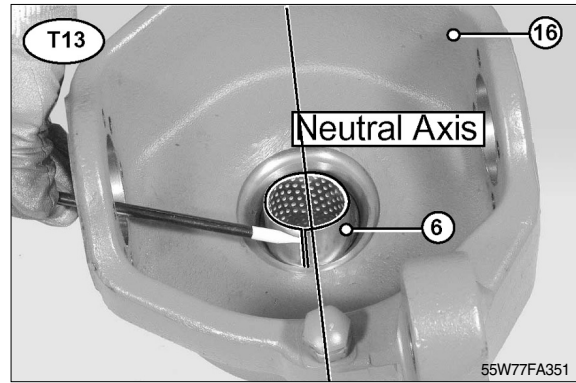

- (2) Lubricate the outer surface of the sealing ring(5); fit them into their seat using tool T14.

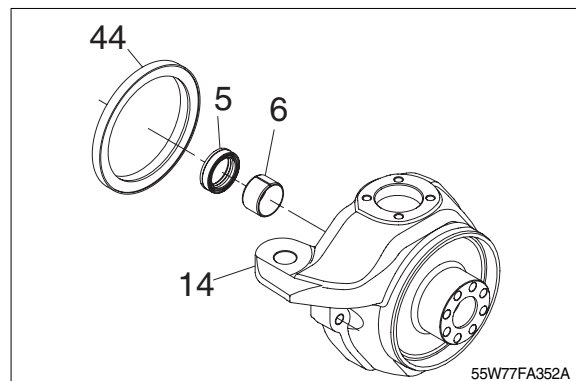
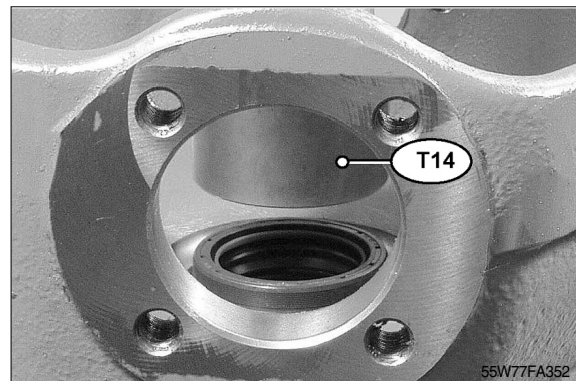

- (3) Using special tool T15 apply a repositionable jointing compound for seals to the outer surface of the sealing ring(44). Position the sealing ring(44) in the steering case(14).

※ Check that the ring(44) is correctly oriented.

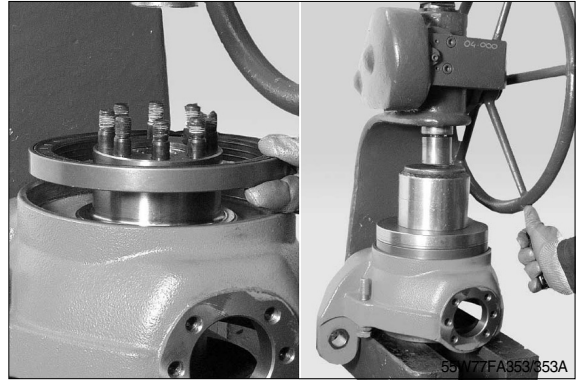

- (4) If the bottom articulation pin(17) has been extracted, position the pin under a press and fit the ball cover(20).

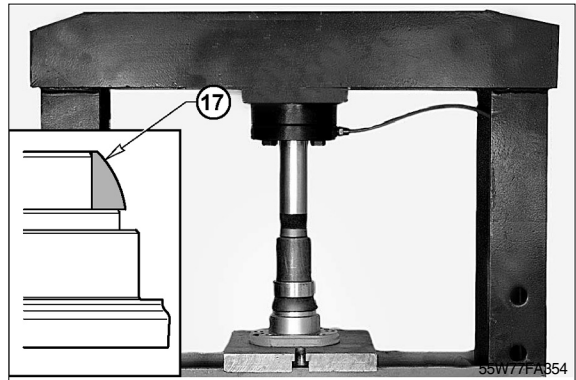

- (5) Fit the front sealing rings(18)(8) onto the articulation pins(4) and (6).

※ Carefully check that the rings are properly oriented(18)(8).

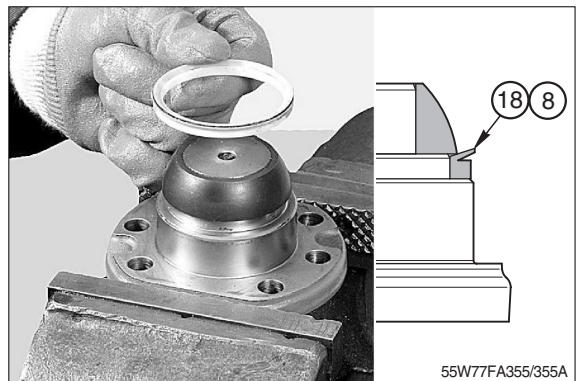

- (6) Lubricate the top bush(7) or the bottom ball bush(17) and fit them into the fulcrum holes of the arm.

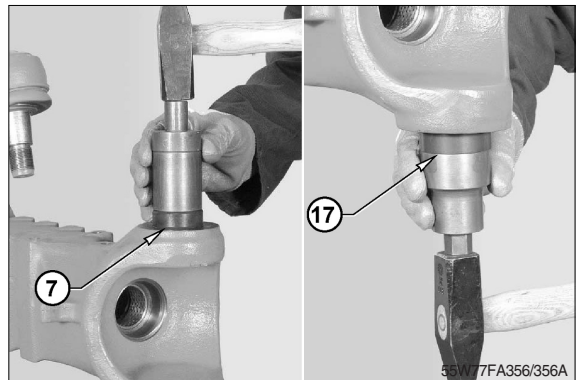

- (7) Lubricate the bushing(2) and the seat of the steering case(1).  
Install the bushing(2), using tool T13.

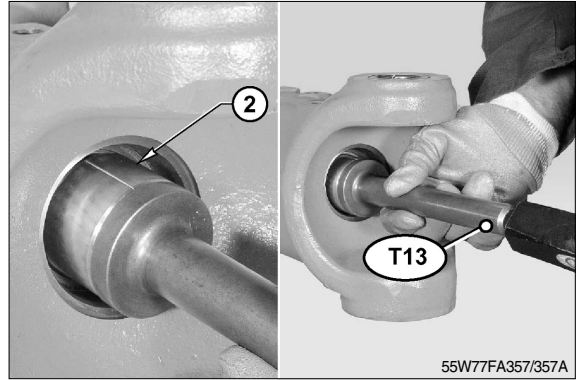

- (8) Lubricate and fit the sealing ring(3) onto tool T14; install the rings into the arm.
- ▲ Pay particular attention to the direction of assembly of the rings.

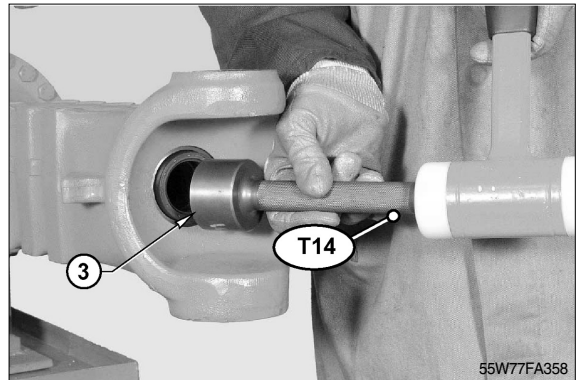

- (9) Insert the u-joint(4).

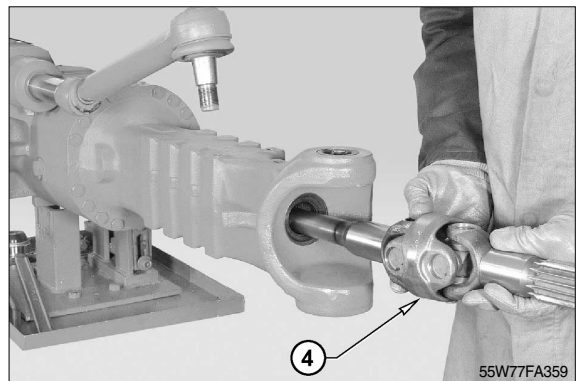

- (10) Lubricate the terminal of the u-joint(4) and install the steering case(14).  
Pay due attention not to damage the dust cover rings and the sealing rings.

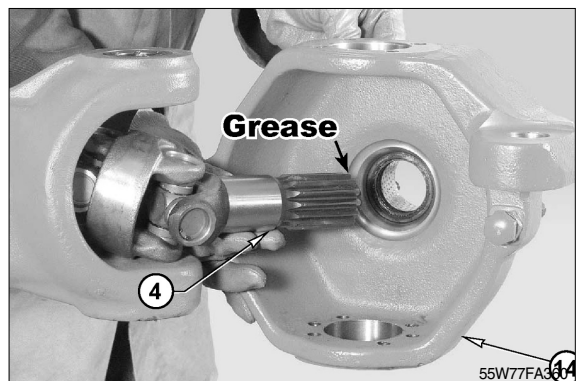

- (11) Prepare a series of shims(9) of 0.4 up to 0.7mm.  
To be assembled under the upper pin(10).

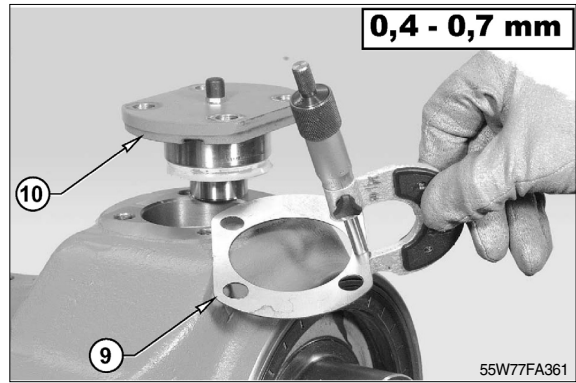

- (12) Lubricate and install the unit in the steering case.



- (13) Lubricate the steering case.

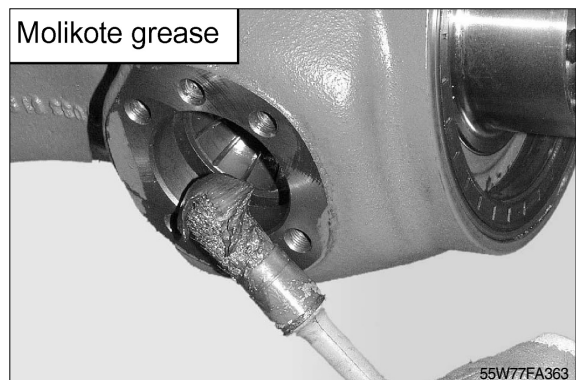

- (14) Fit the unit(20) in the steering case(14).  
Position the screws(19) and tightly tighten.

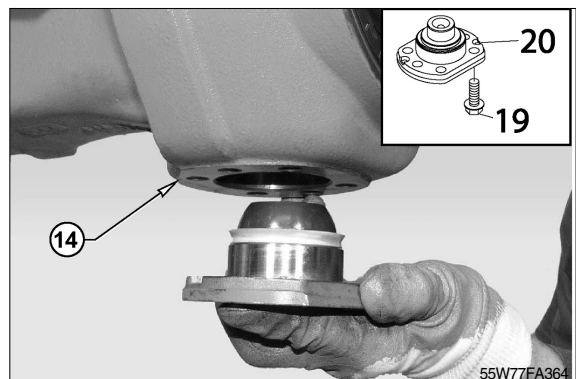

- (15) Tighten the new fitting screws(13) of top articulation pins in sequence using the cross tightening method.

Torque wrench setting : 90~100Nm  
(66.3~73.8lbf · ft)

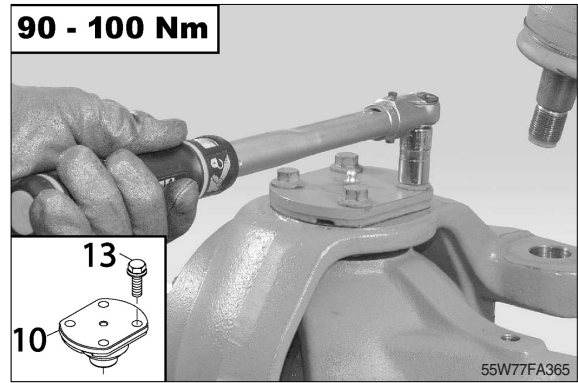

- (16) Tighten the new fitting screws(19) of bottom articulation pins in sequence using the cross tightening method.

Torque wrench setting : 90~100Nm  
(66.3~73.8lbf · ft)

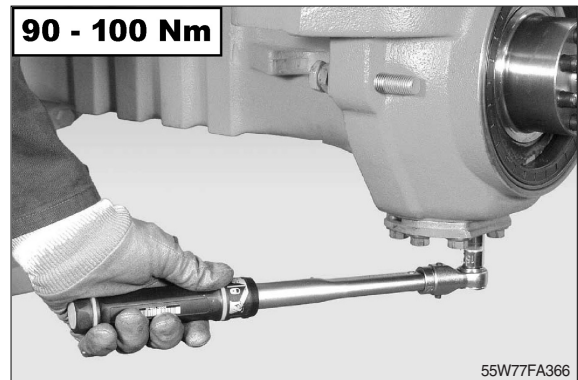

- (17) Check by means of a lever that there is no vertical gap.

In case there is any gap, determine the width and reduce it by removing shims.

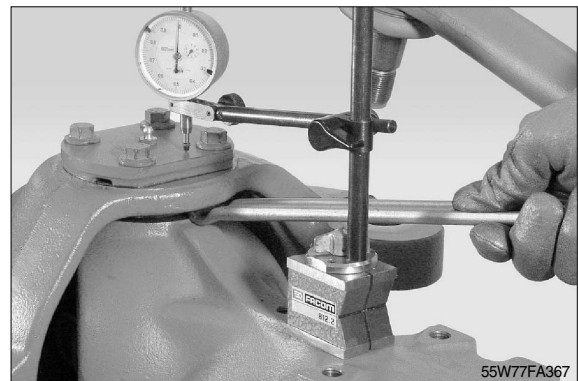

- (18) Check the torque of the pins, which has to be between 40 and 80Nm(29.5~59lbf · ft).  
If the preliminary measured value is too high, the shims have to be increased.



- (19) Look for the position of the notch regarding the safety cotter pin hole when the nut is finally locked max 300Nm (221.3lbf<sub>i</sub> /ft).

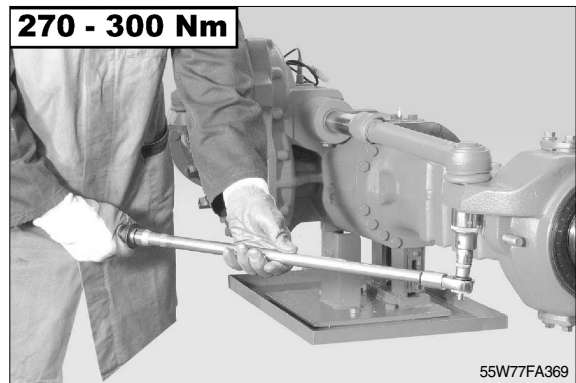

- (20) Bring the lockscrew to the quote at the measure previously survey.

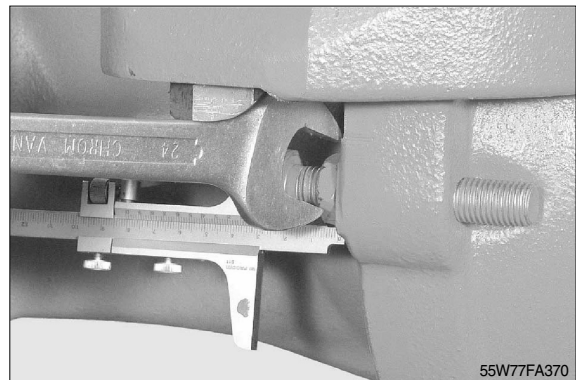

- (21) Position the lower part of tool T1 and the thrust block of the external bearing(38).

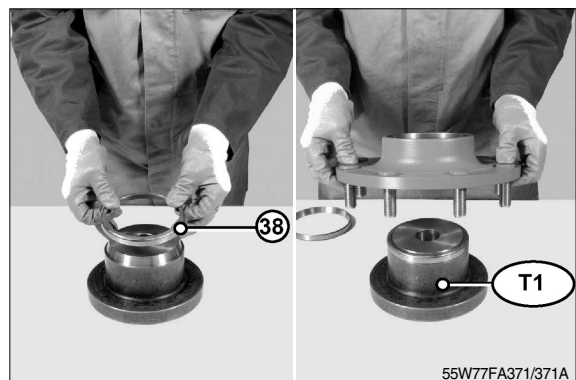

- (22) Lubricate the seats of the bearings and position the hub(41) on tool T1; position the thrust block of the internal bearing(43).  
 ※ Check that the thrust block is correctly oriented.

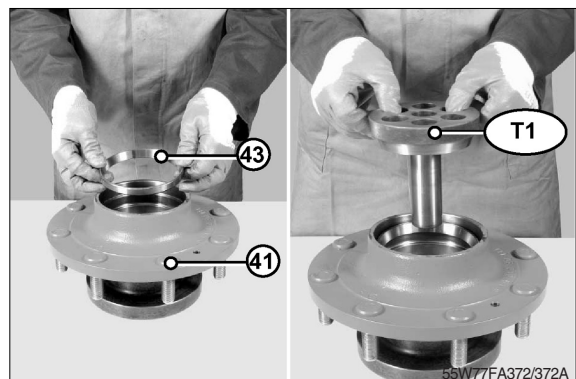

(23) Install the external bearing(38).

- ※ Move the bearing to the limit stop by hammering lightly all around the edge.

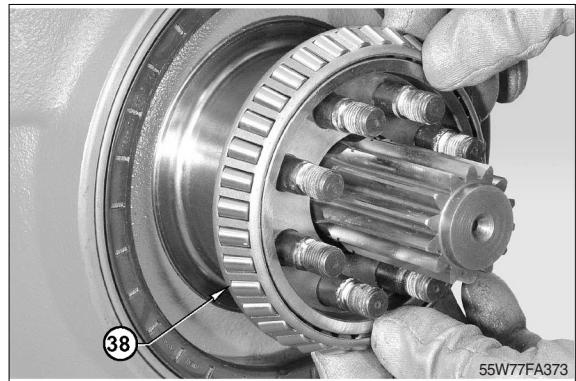

(24) Install the wheel hub(41).

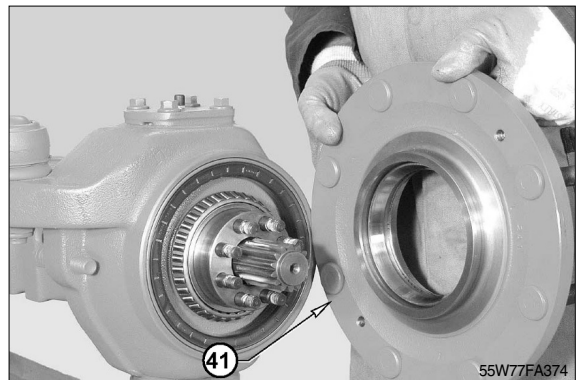

(25) Install the crown wheel(36).

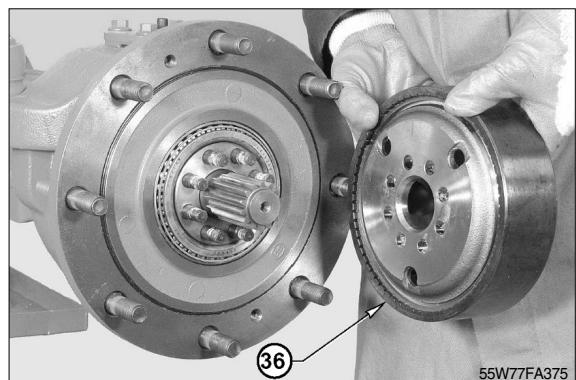

(26) Fit the complete crown flange(36).

- ※ In order to fasten the flange(36), use a plastic hammer and alternately hammer on several equidistant points.

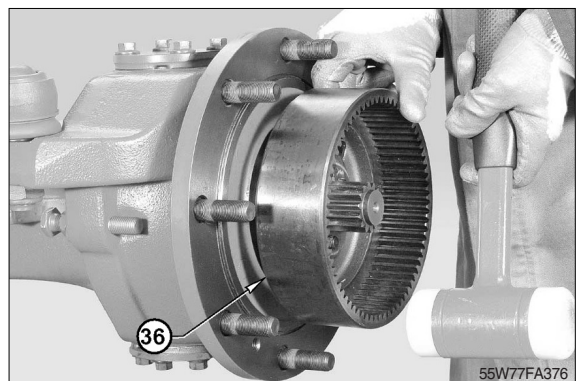

(27) Install the security flange(33).

Using tecno lube/101, grease the surface of the safety flange(33) that touches the crown wheel.

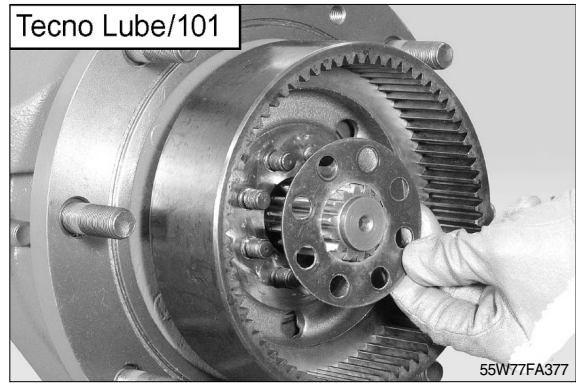

(28) Coat the nuts(23) with loctite 242 and screw them.

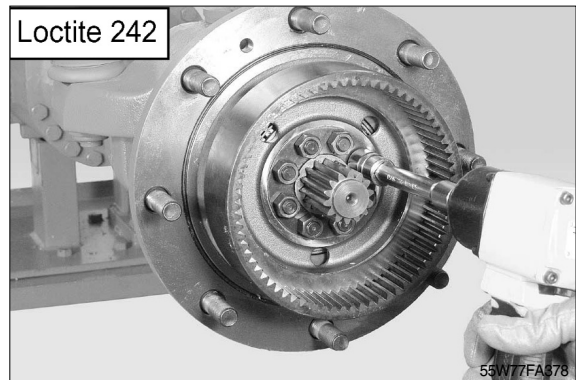

(29) Tighten nuts(32) in two stages, using the criss-cross method.

Initial torque wrench setting : 90Nm  
(66.3lbf · ft)

Final torque wrench setting : 100Nm  
(73.8lbf · ft)

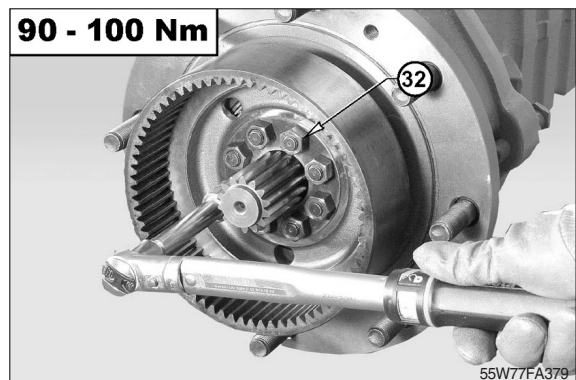

(30) Install the distance piece(31).

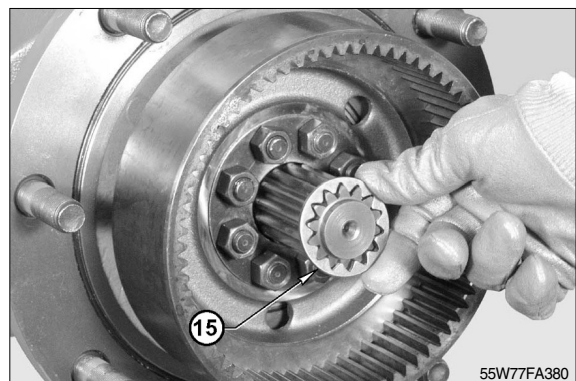

(31) Install the snap ring(31).

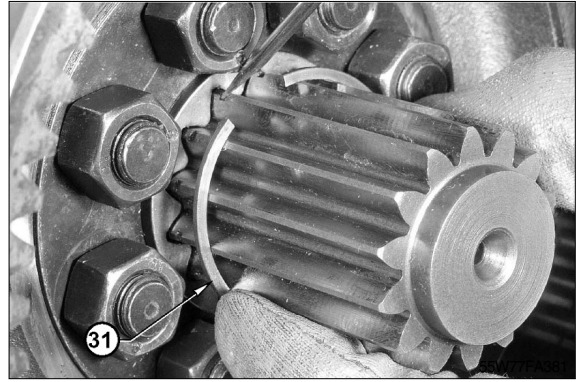

(32) Check the continuous rolling torque on the hub.  
Torque 7~20Nm(5.2~14.8lbf · ft)

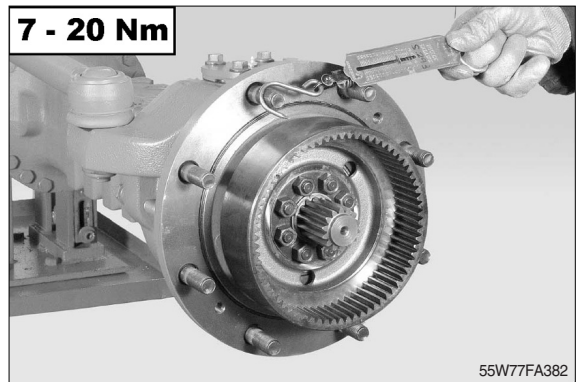

(33) Check the condition and position of the O-ring(37).

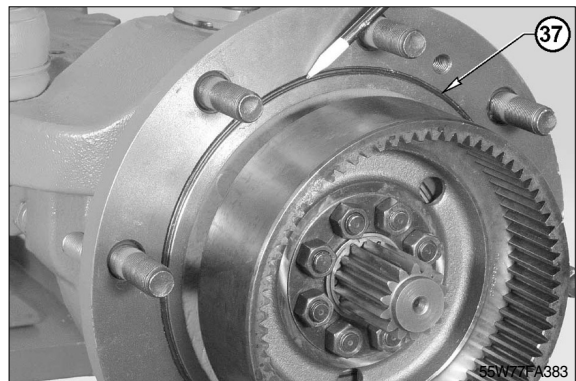

(34) Install the spherical washer(6).

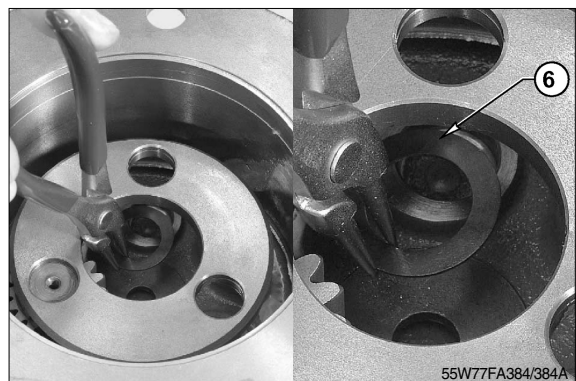

(35) Install planetary gears complete with roller bearing(3).

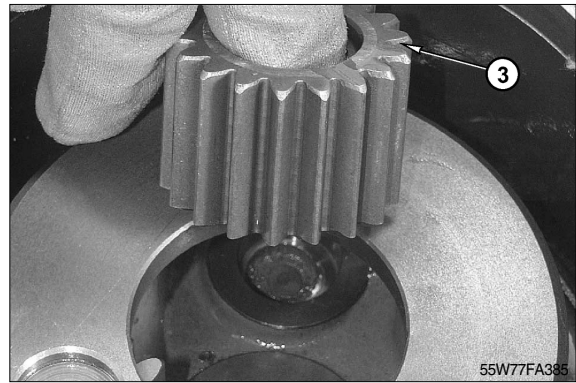

(36) Install the others friction washers.

※ Two friction washers for every planetary gear.

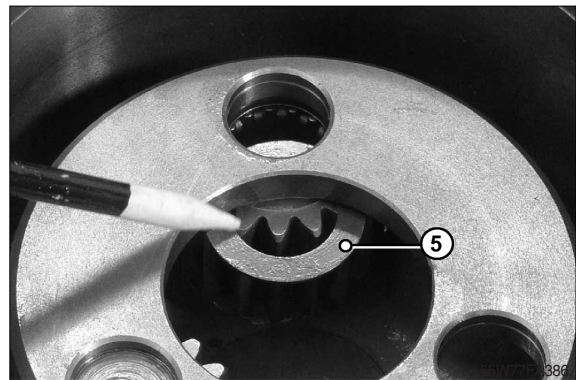

(37) Check the concentricity of the planetary gear, the seat and friction washers.  
Using a screw M6 install the pin(2).

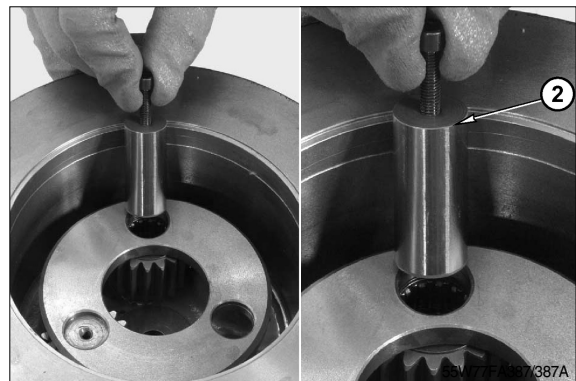

(38) Carefully check that pin is completely inserted and install the snap rings(1).

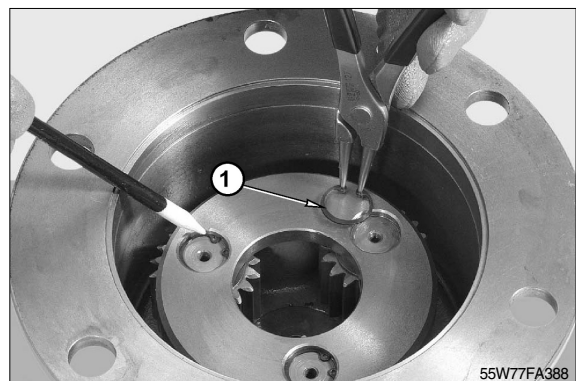

(39) Fit the planetary gear cover(18) onto the wheel hub(4).



(40) Torque wrench 40~50Nm(29.5~36.9lbf · ft).



## 8. STEERING CYLINDER

### 1) Disassemble

- (1) Remove the centring sensor(21) of the steering piston.

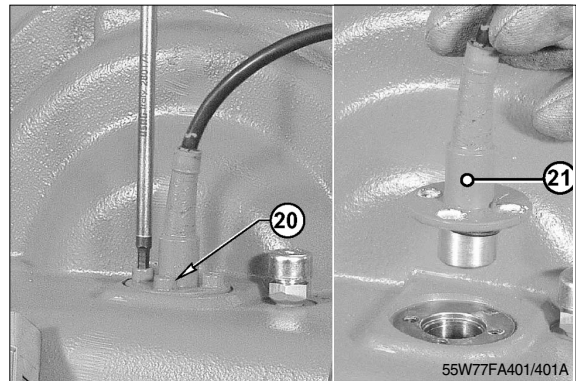

- (2) Remove the nuts(18) that lock the articulation pins(14).

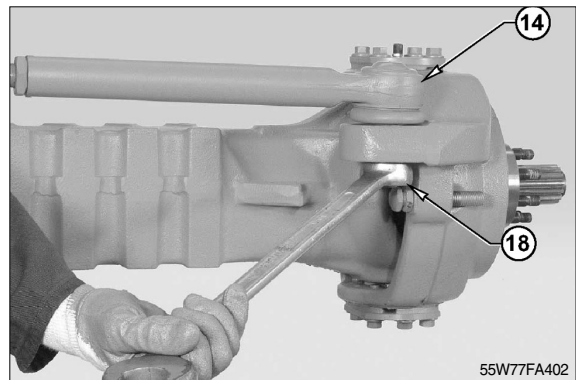

- (3) Disconnect the tapered pins of the articulation(14) from the steering case by means of puller.

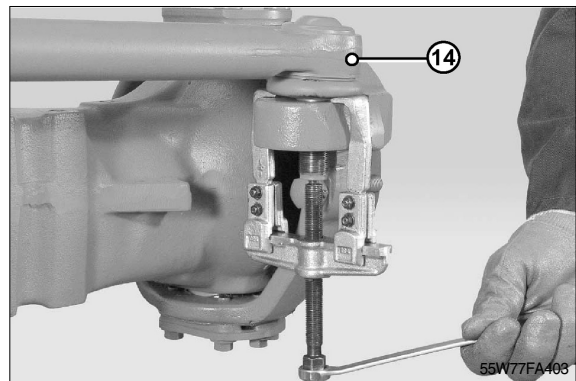

- (4) If the connection of the steering bars includes a safety collar, raise the border.

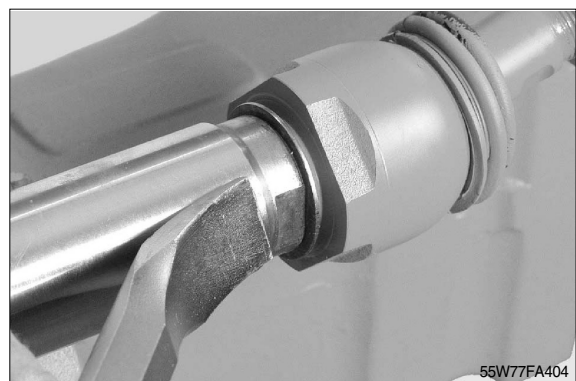

- (5) Disconnect left and right steering bars from the piston.

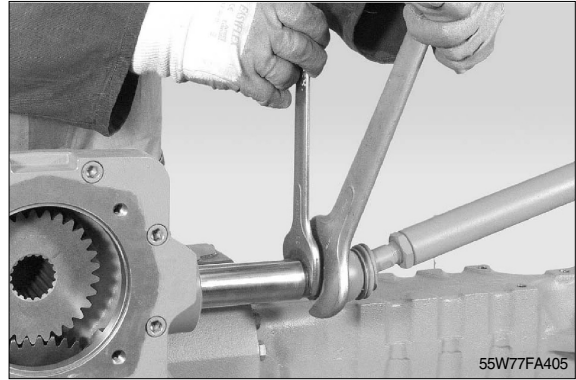

- (6) Remove the securing screws(19) from the steering cylinder(16).

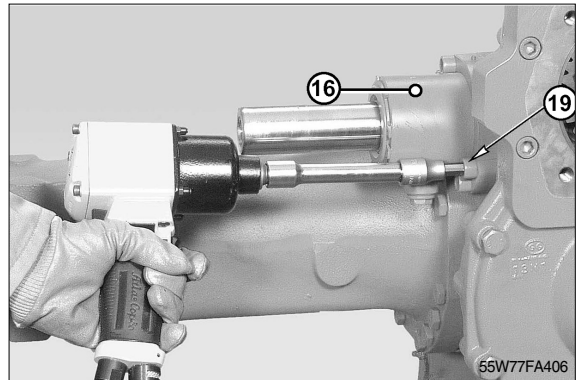

- (7) Extract the cylinder(16) using a plastic hammer.



- (8) Using a screwdriver, remove the snap ring (1) of the cylinder head.
- ※ Before attempting to disassemble the unit, drain the oil in the cylinder chambers completely.

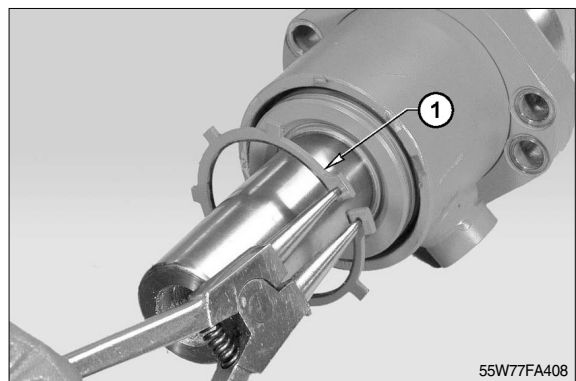

(9) Lightly tap the cylinder head(2) with a plastic hammer so as to push it inside the cylinder(3).

※ Insert the cylinder head so it is flush with the cylinder.

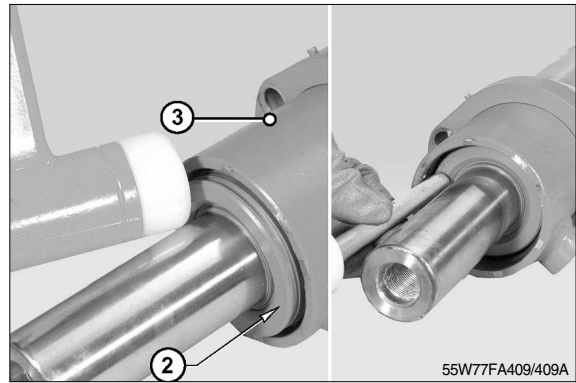

(10) Using a punch, force the stop ring(4) located inside the cylinder(3) and extract ring using a screwdriver.

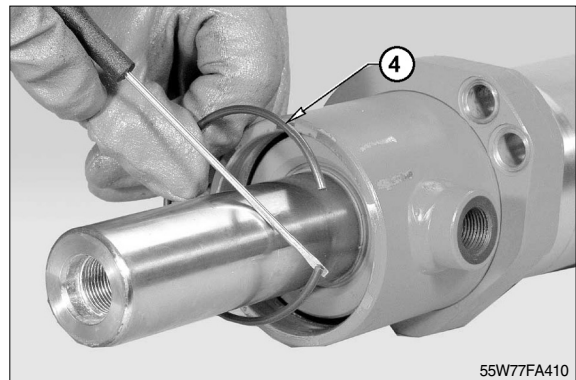

(11) Take the cylinder unit a part by extracting the head first, followed by the piston.

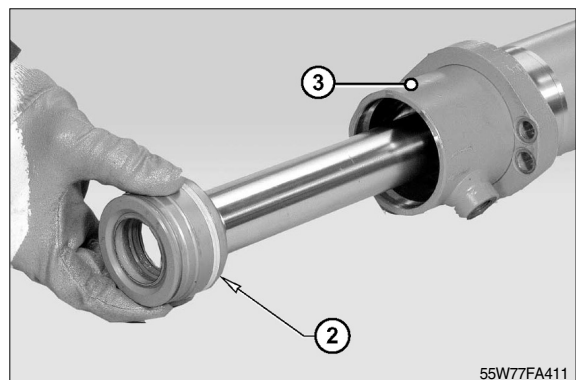

(12) Note down direction of installation of piston whose seal ring is oriented towards cylinder head.



(13) Remove all seals, anti-extrusion rings and scraper rings from head(2), cylinder(3) and piston(5).

- ※ All seals must be replaced every time the unit is disassembled.
- ※ Particular attention must be paid not to damage the seats of both seals and piston slide.



## 2) Assembly

- (1) Grease and install the piston rod seal ring(6), rod wiper(8) and back up washer (7)

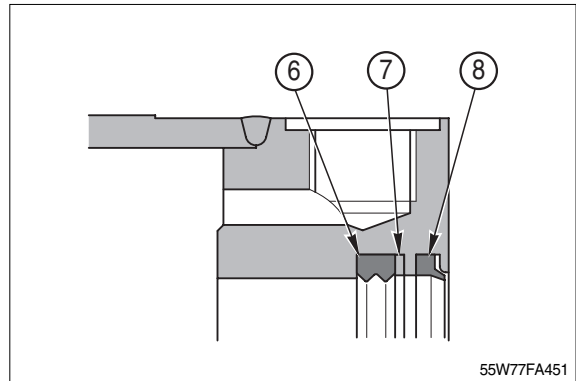

- (2) Grease and install the piston rod seal ring(6), rod wiper(8) and anti-extrusion ring(7) into the head(2).

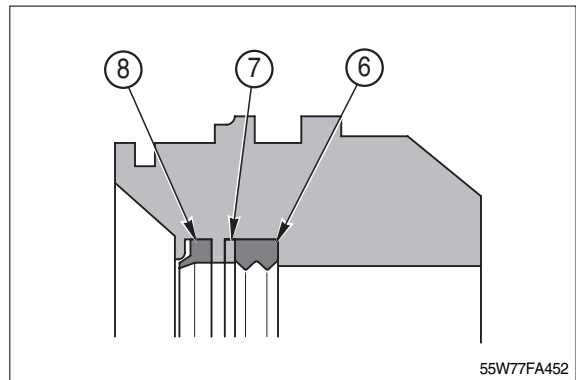

- (3) Fit seal(9) on the outside of the head(2).  
※ To ease installation, grease the outer surface of the piston.  
※ Do not roll the seal(9).

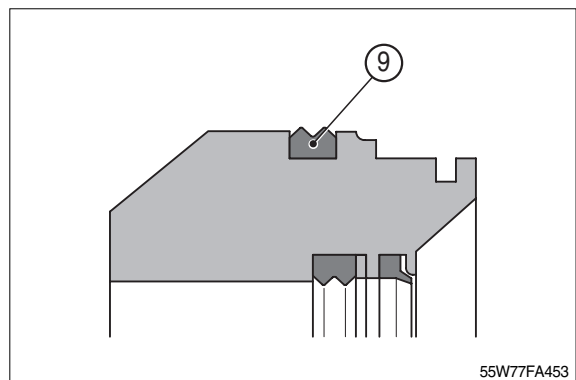

- (4) Prepare piston(5) by fitting it with magnetic ring(11) anti-extrusion ring(10) and piston seal(13).  
※ To ease installation, lubricate with grease.

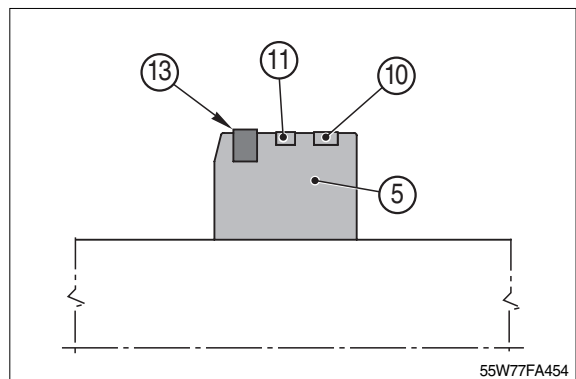

- (5) Centre the shaft on the cylinder(3) so that it fits into the piston(5).  
※ Apply a little grease to seals and cylinder.

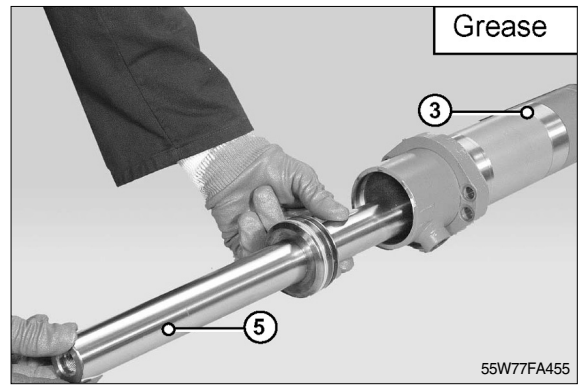

- (6) Push the piston(5) into the cylinder for 100mm using a plastic hammer.

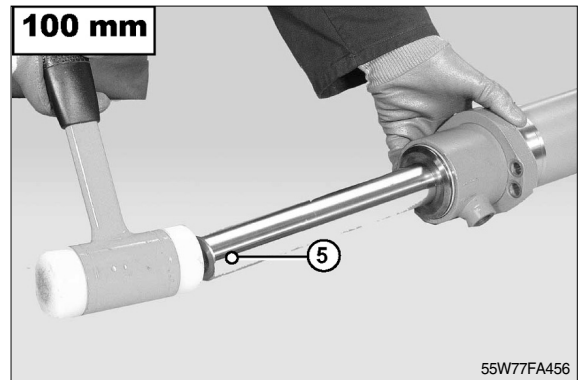

- (7) Apply grease to head(5) seals, fit the head onto the piston and push it into the cylinder(3) using a plastic hammer.  
※ Insert the head as to line it up with the edge of the cylinder.

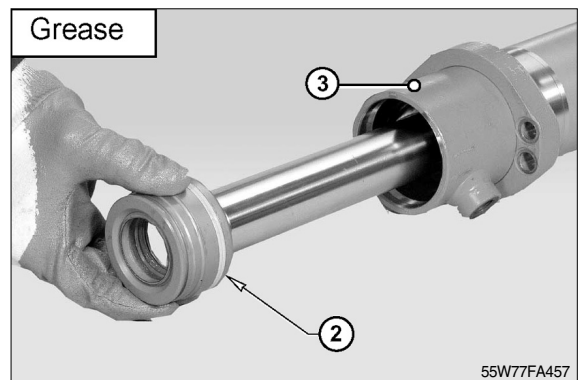

- (8) Introduce the stop ring(4) and ensure that it sets in the seat of cylinder(3).

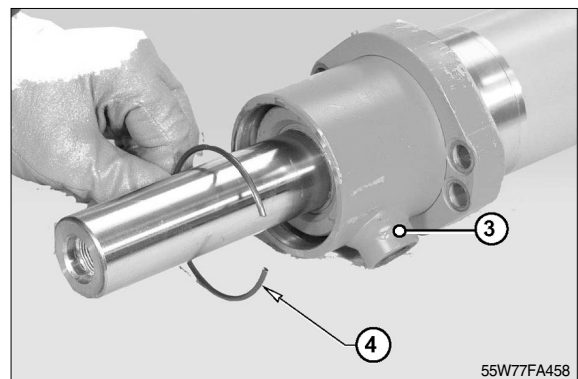

- ※ To insert the heading not to go beyond with the ring of gasket the hole of feeding because it could be cut.

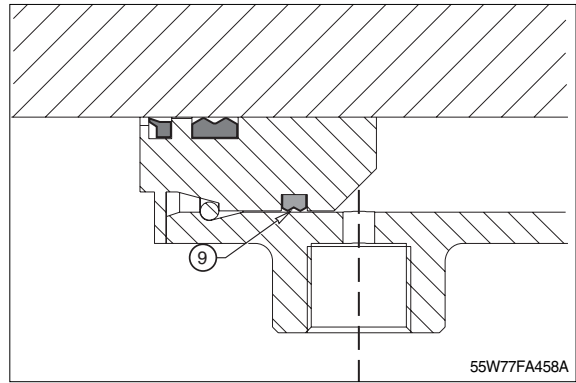

- (9) Using two screwdrivers or levers, force the head until it is seated against the stop ring (4).  
Fit the snap ring(1) on the head(2).
- ※ Make sure that the snap ring(1) is securely fastened in its seat.  
If necessary, force it into its seat using a drift and a hammer.

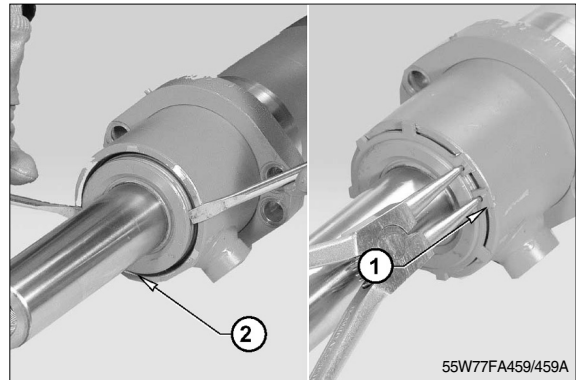

- (10) Renew at each reassembly.



- (11) Check that the O-rings(17)(15) of the axle unit are in good condition; lubricate the seats of the seals and fit the steering cylinder(3).

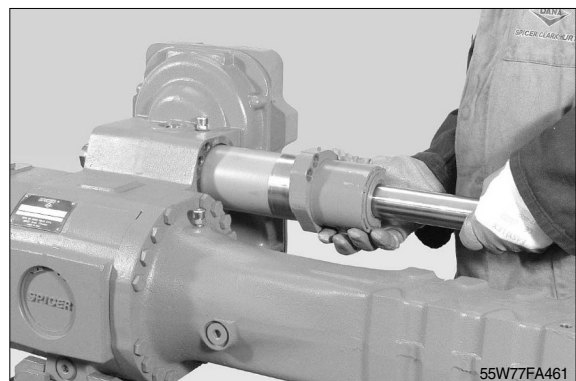

(12) Lock the cylinder by cross-tightening the screws(3).

Torque wrench setting: 90~100Nm  
(66.3~73.8lbf · ft)

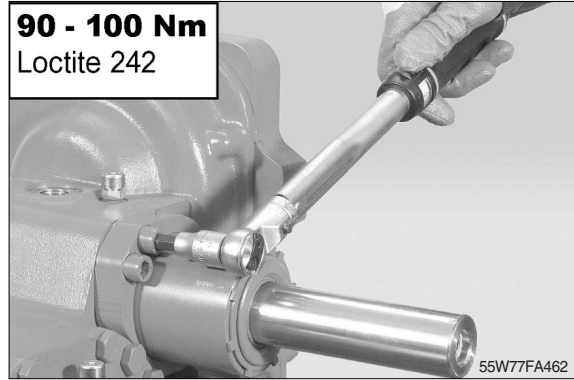

(13) Apply loctite 242 to the thread and connect the steering bars by screwing the terminals onto the piston stem.

Torque wrench setting: 240~270Nm  
(177~199lbf · ft)

※ Versions with coupling require that the rim of the articulation is riveted onto the surfaces of the piston stem.



(14) Insert the pins(18) in the steering case and lock into position using a torque wrench setting of 270~300Nm(199~221 lbf · ft).



(15) Install the proximity(21) for checking piston centring-if applicable and tighten the screws(20).

Torque wrench setting: 5~8Nm(3.7~5.9 lbf · ft).

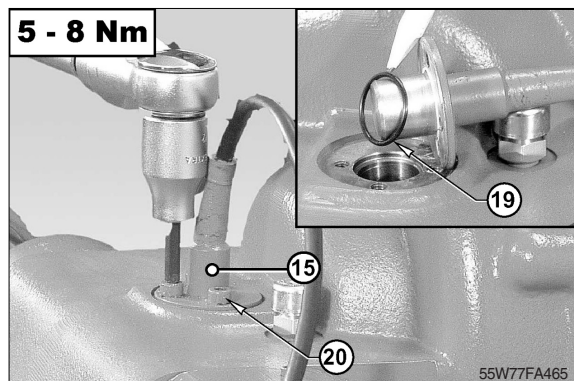

(16) Using a level "B", check that tools are perfectly flat and parallel to each other.

- ※ Eliminate the action of the negative brake, if fitted. Apply tools T16 to the hubs and lock them.

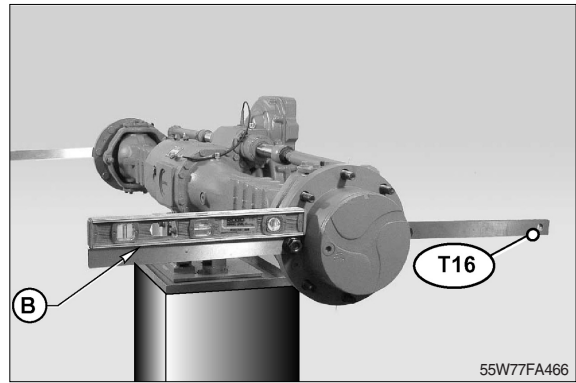

(17) Connect the sensor(21) to the inspection device according to either diagram.

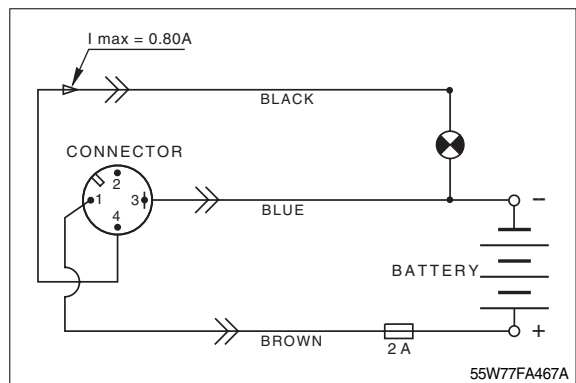
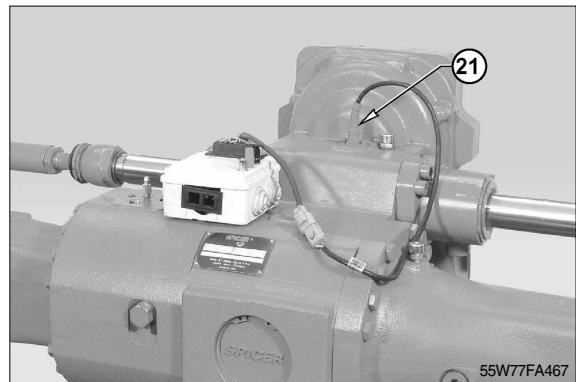

(18) Centre the piston by slowly moving it first in one direction then in the other and position it half way on the stroke, which is determined by the switching on and off of the signal lamp of the inspection device in the reversal stage.

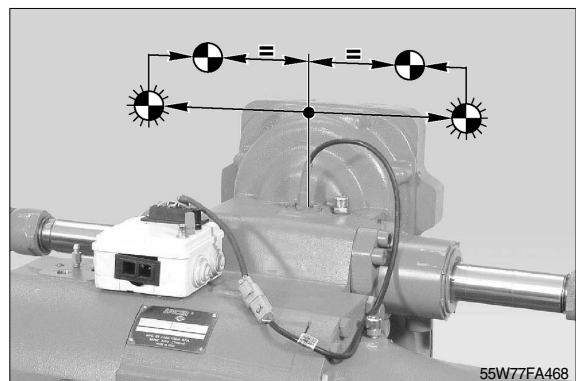

(19) Inspect jut "C" on one side of the piston and note down the size for checking later adjustments.

- ※ If cylinders come without a sensor, the centring of the piston must be carried out on the basis of the maximum stroke.

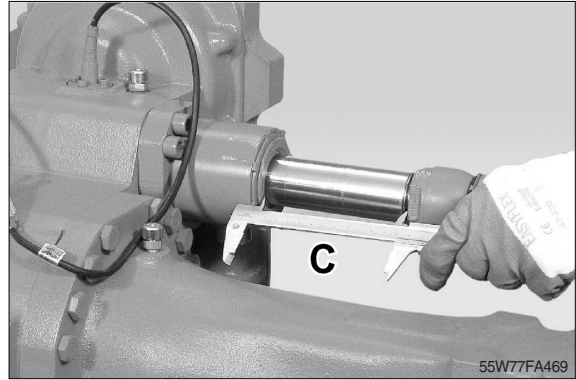

(20) Without moving the piston, check front and rear size at the edge of tools T16.

Max. difference: 0.6~0.7mm

- ※ In order to check the rear size, rotate the bevel pinion and check that tools T16 are flat.

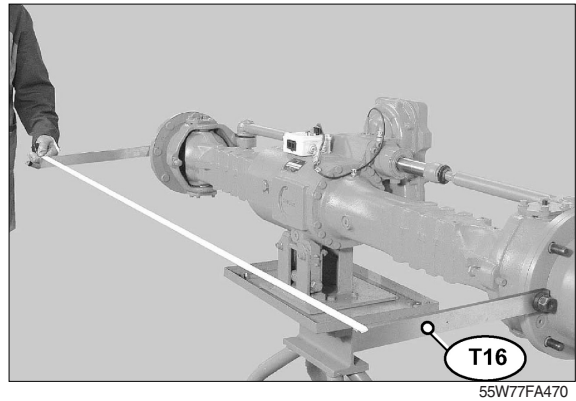

(21) If necessary, adjust convergency without moving the centring of the piston and adjust the length of the steering bars(14).

- ※ With a half turn of screw, the front size is reduced by about 3mm, whereas the rear one is increased by about 3mm.

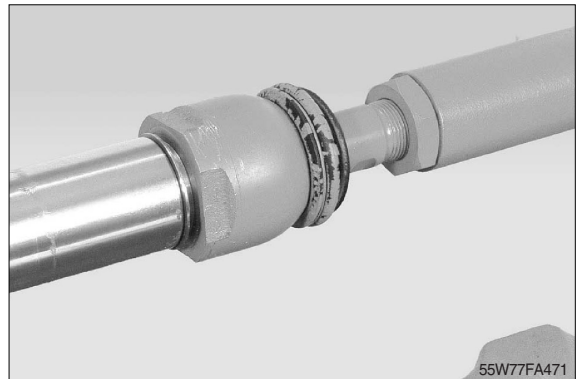

(22) Unloose the nuts and screw them onto the ball-and-socket joints.



(23) Hold the articulations still and rotate the ball-and-socket joints.

Once the convergency has been adjusted, lock the nuts.

Torque for nut: 240~270Nm(177~199lbf · ft)

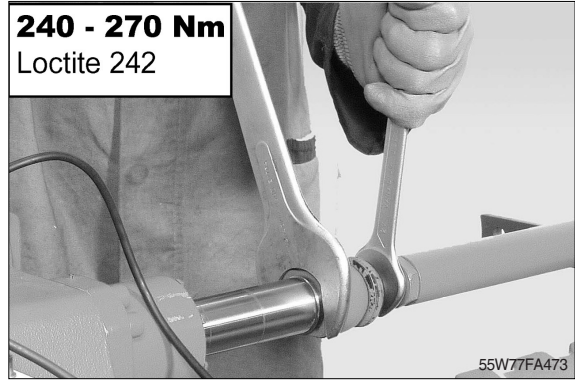

(24) Adjusting the steering angle

Loosen the nut of one of the adjusting screws on cylinder side.

※ Perform the same operations on both sides(see diagram).

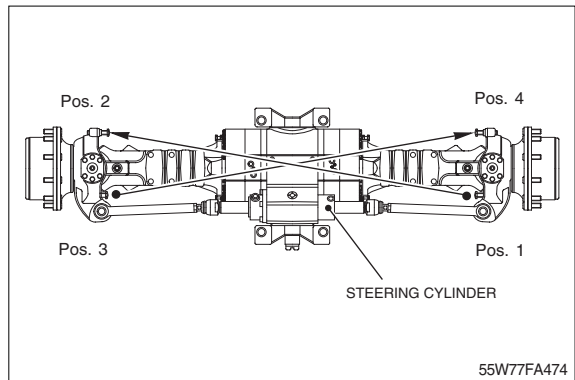

(25) Adjust the jutting portion of the screw according to data shown in the table.

Lock into the position with nut tightened to max 148Nm(109.2lbf<sub>i</sub> /ft).

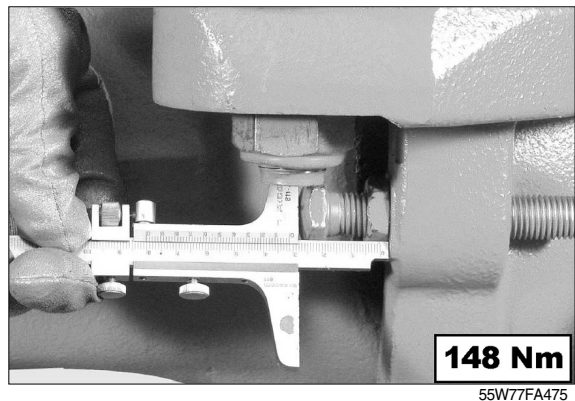

Requested steering angle : value $\alpha$	25°	27°	30°	32°	35°	36°	40°	42°	45°
Steering cases versions based on max. steering angle.	Value W = Adjustment of the steering stop screw, steering cylinder side(mm).								
35° max angle.	55.1	51.2	45.4	41.4	35.0				
45° max angle.			57.4		47.0	44.7	35.8	31.2	24.6

(26) Perform one full steering operation until the adjusted screw leans against the arm stop.

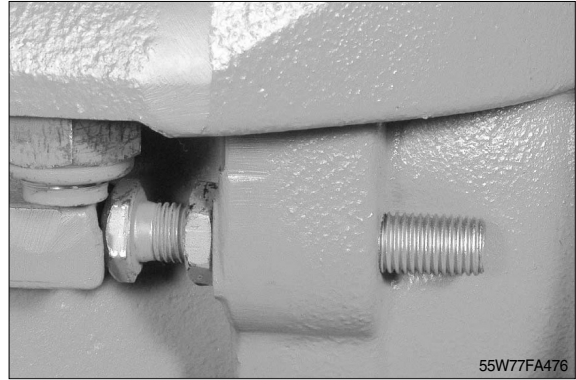

(27) As you hold the adjusted screw in position against the arm stop, adjust the screw opposite, on non-cylinder side, until it leans against the arm stop.

**▲ The screws must lean against the respective arm stops all at the same time.**

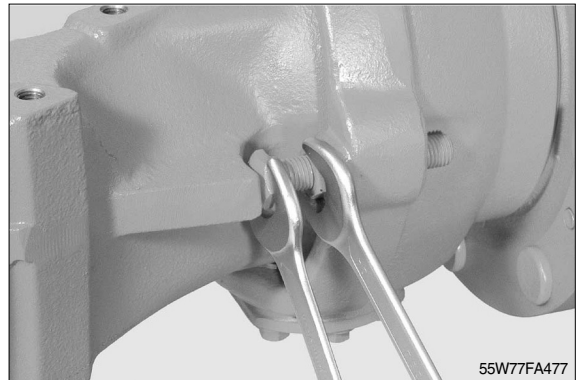

## 9. SPECIAL TOOLS

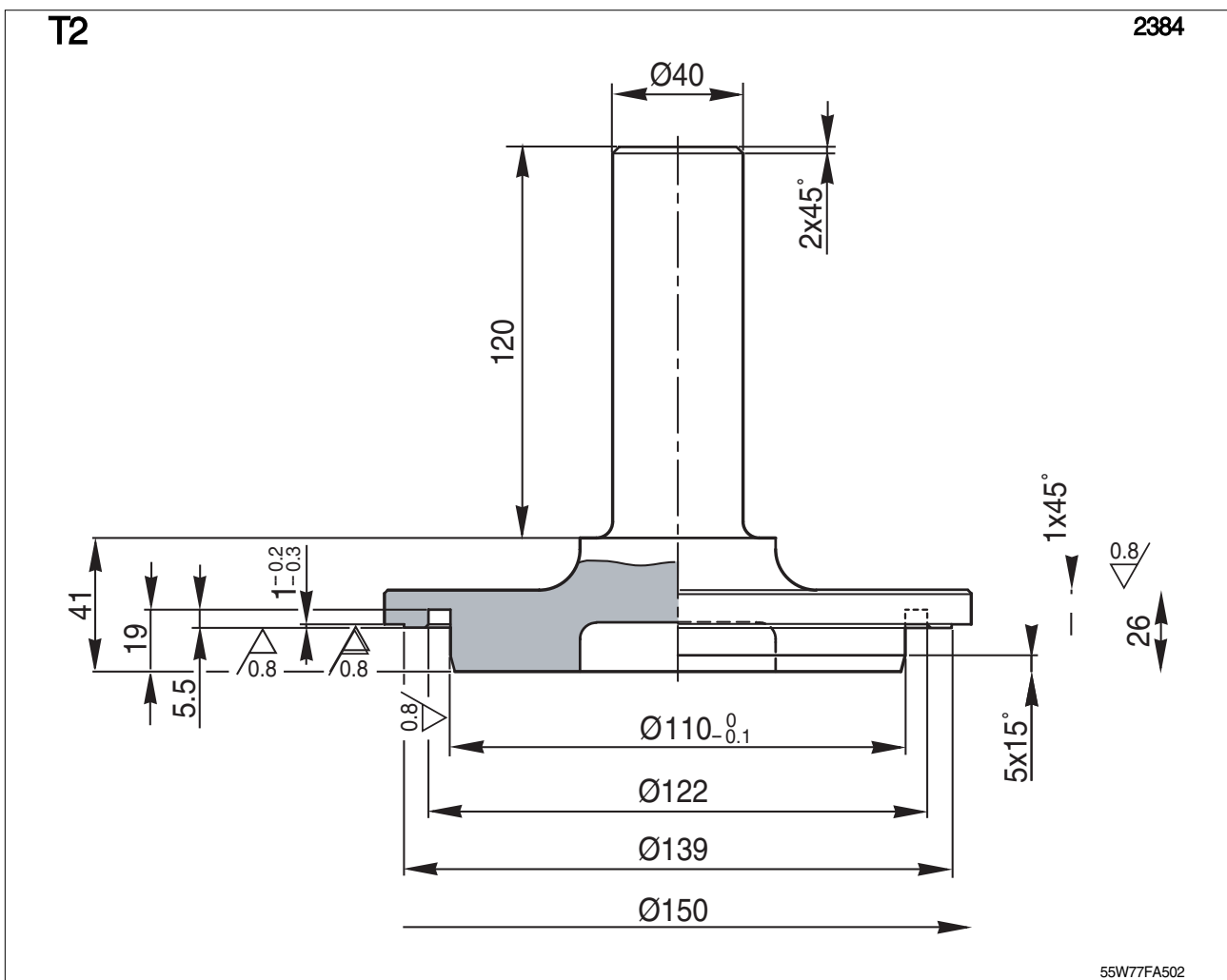
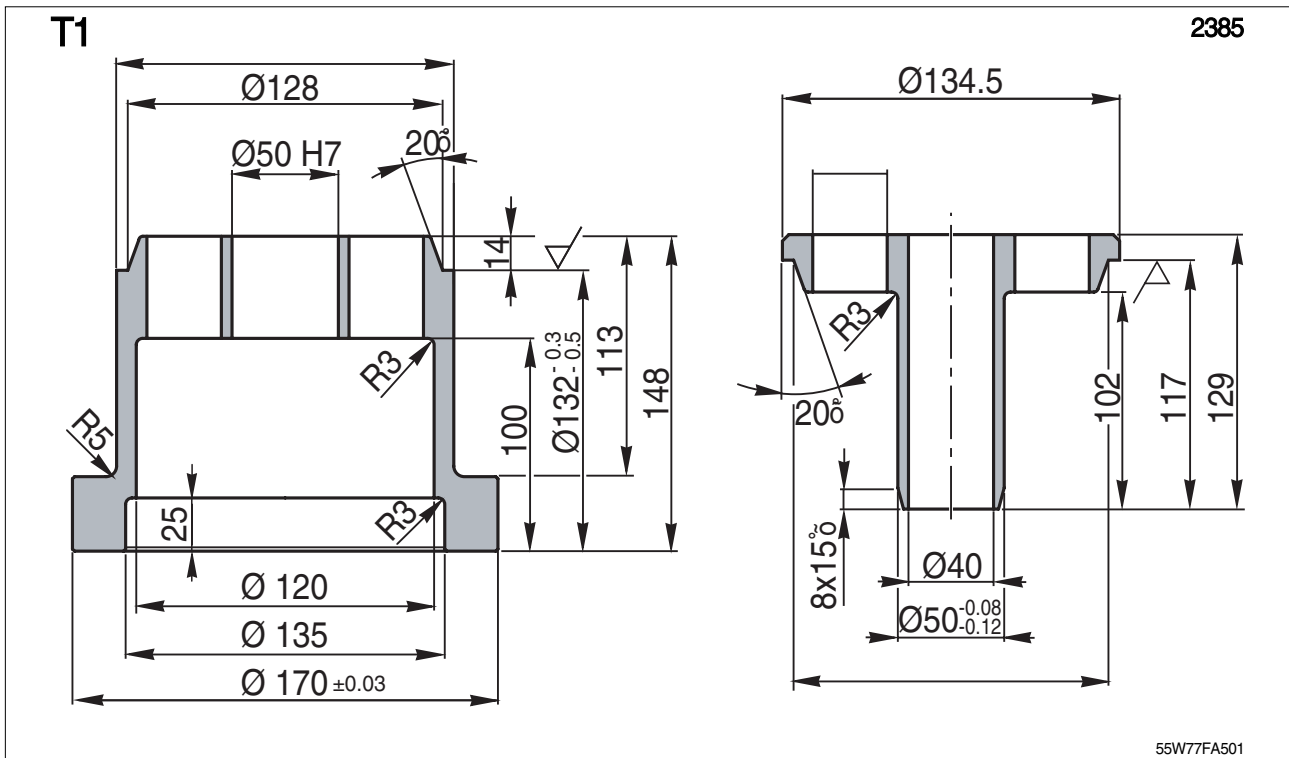





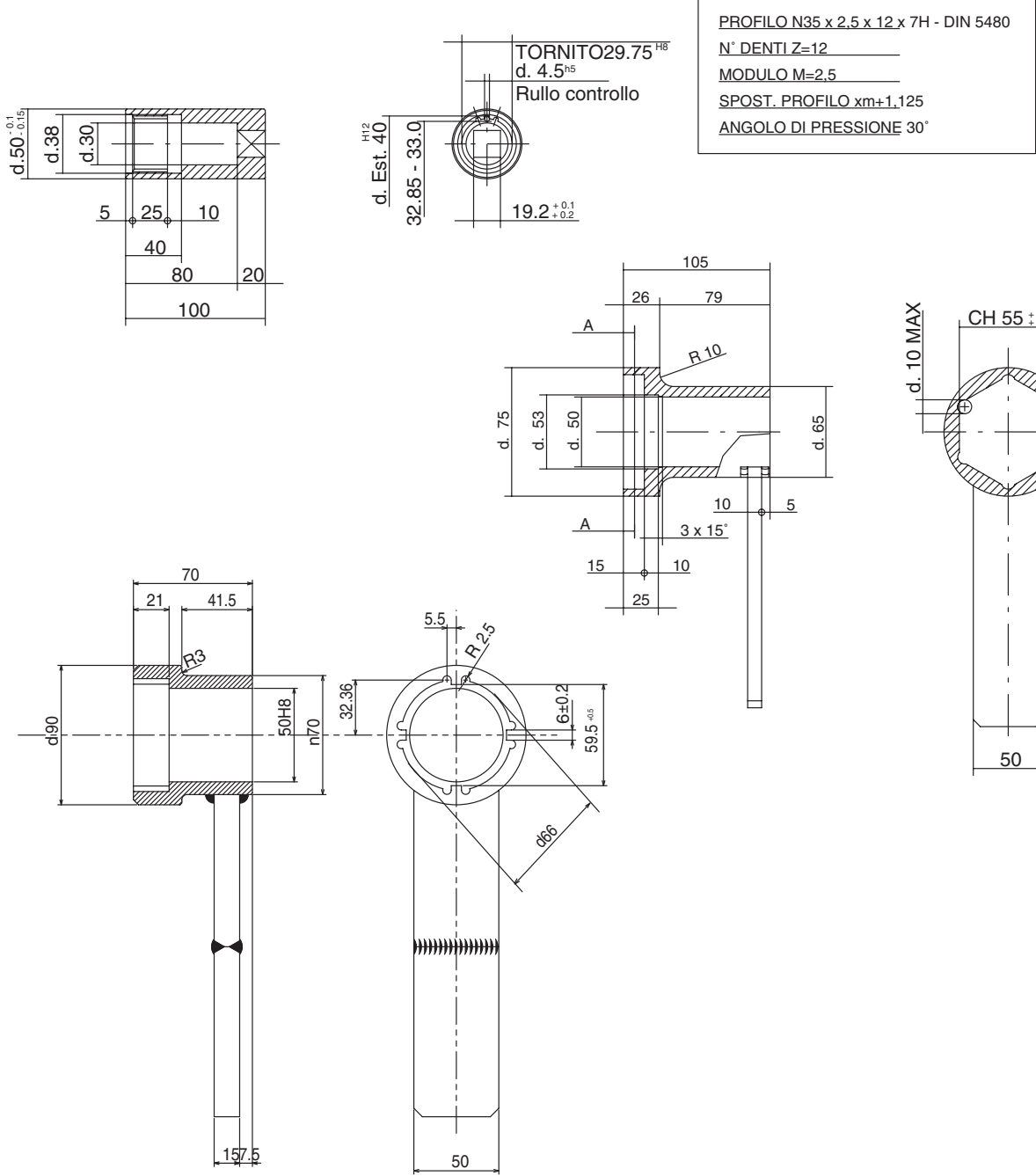

T7

861

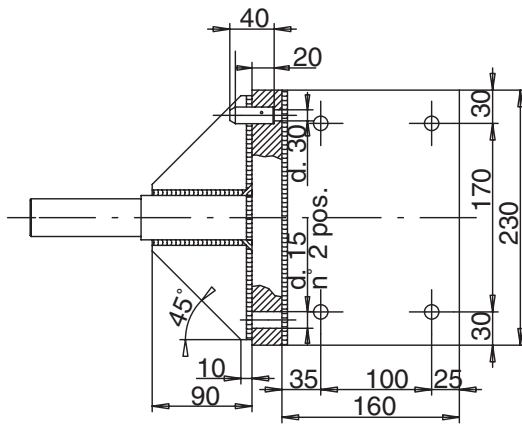
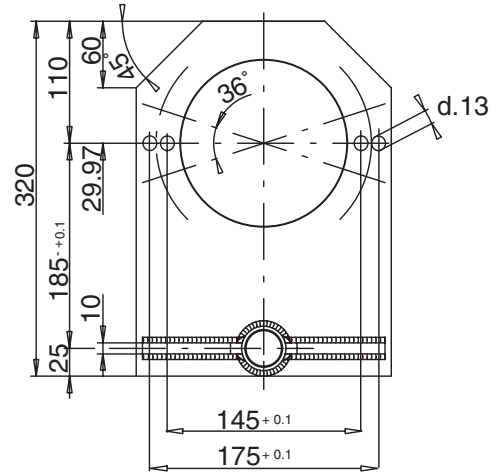
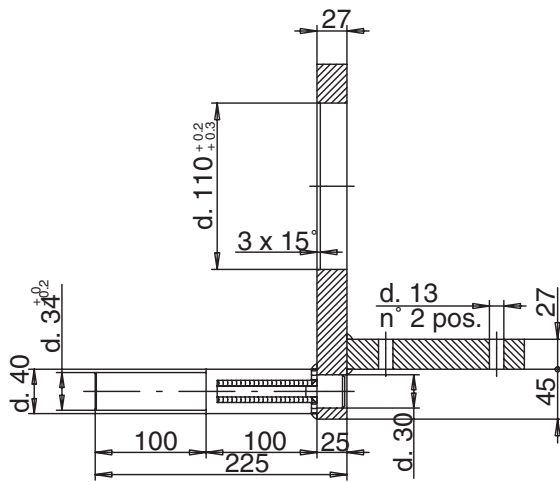

55W77FA507

T8 2 PIECES

1330

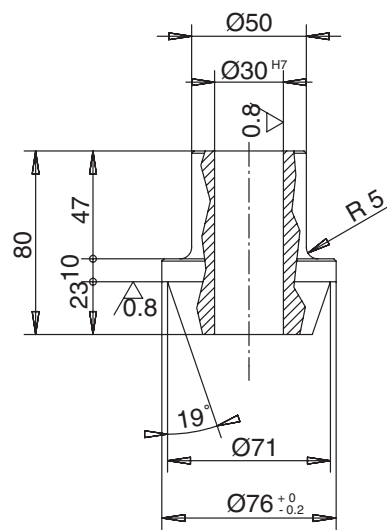
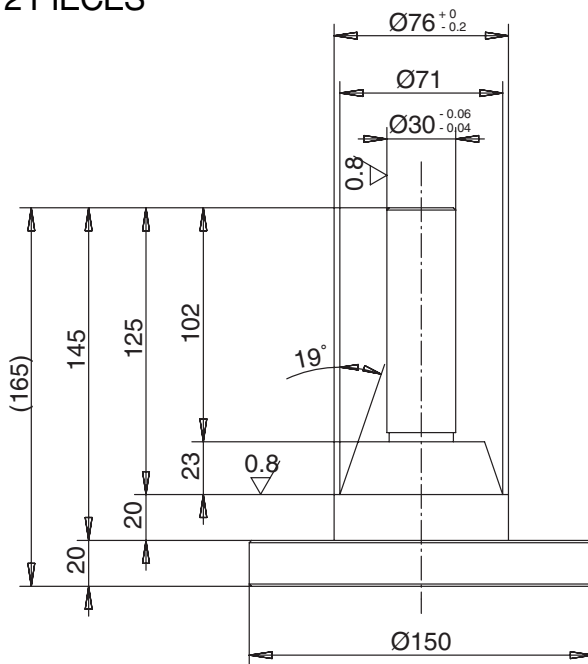

55W77FA508

T9

2389

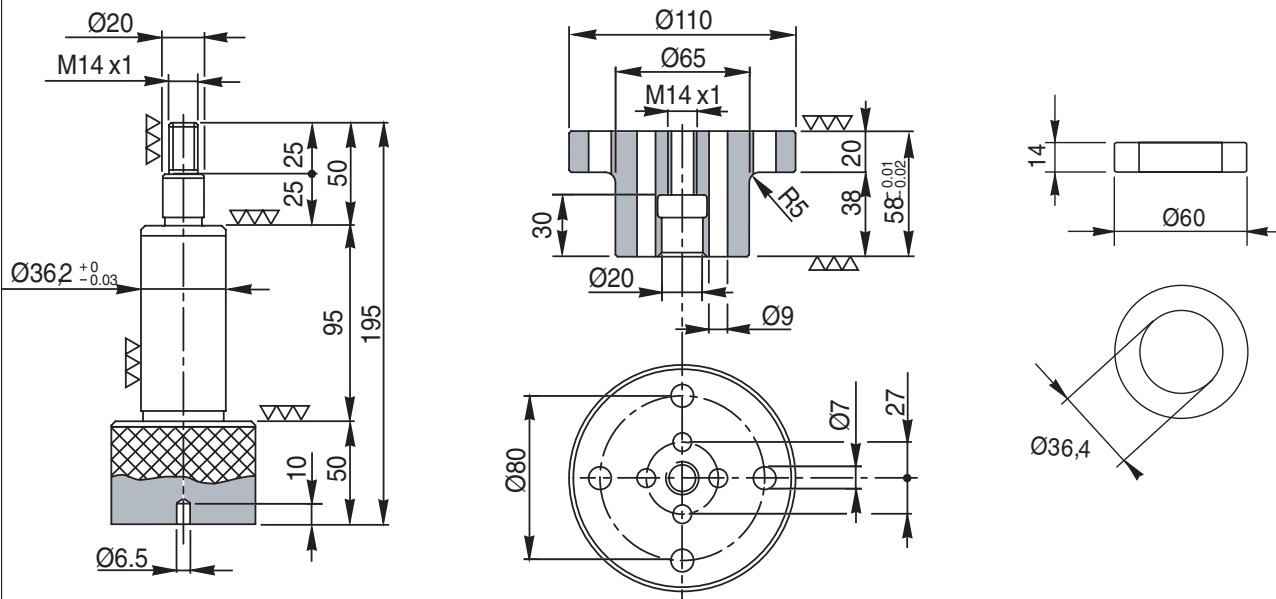

55W77FA509

T10

2390

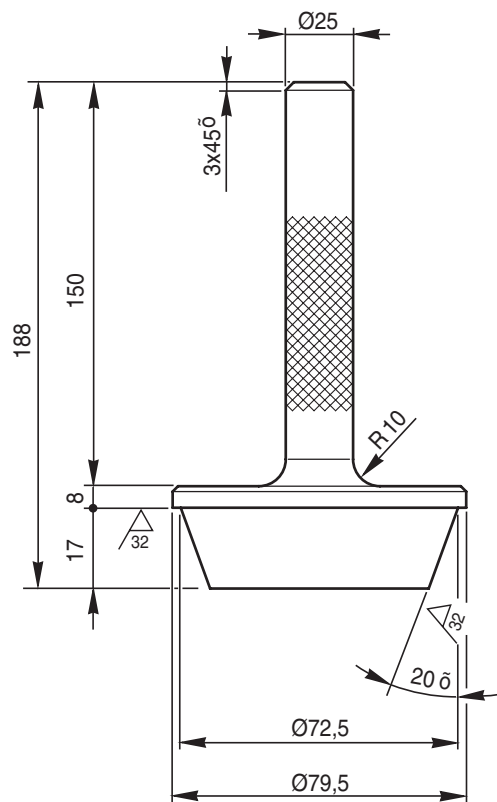

55W77FA510

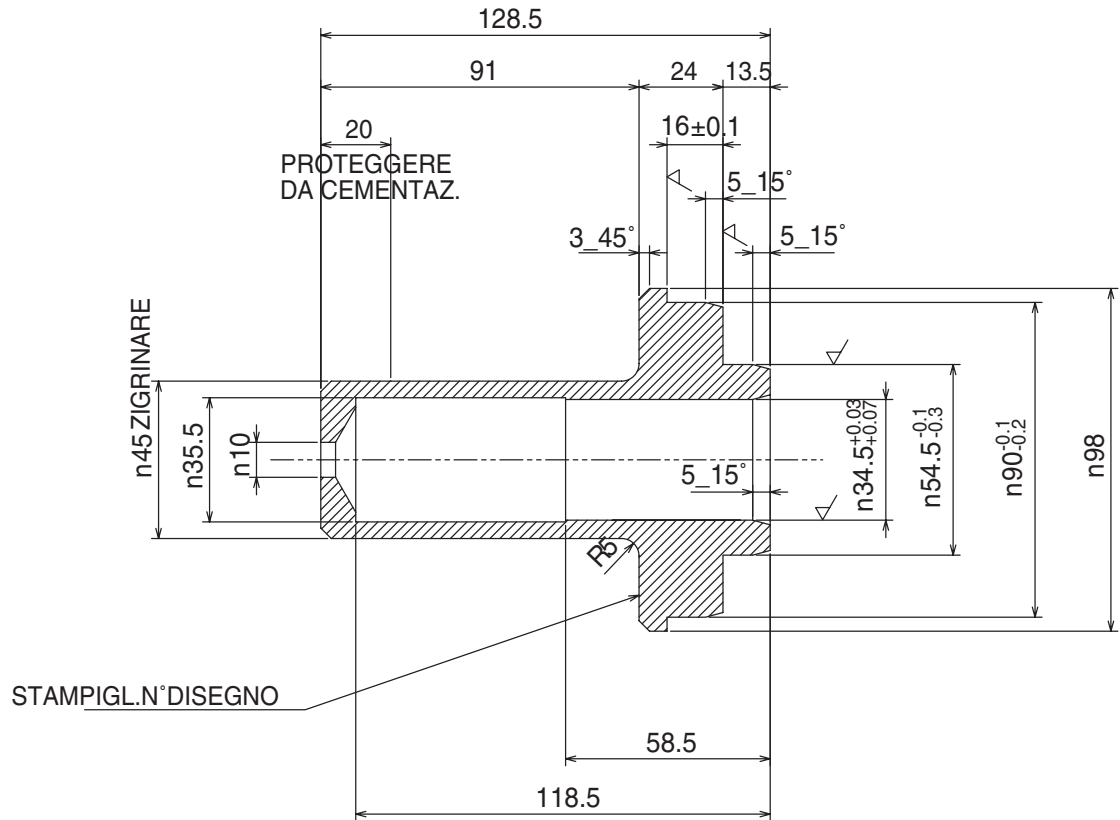
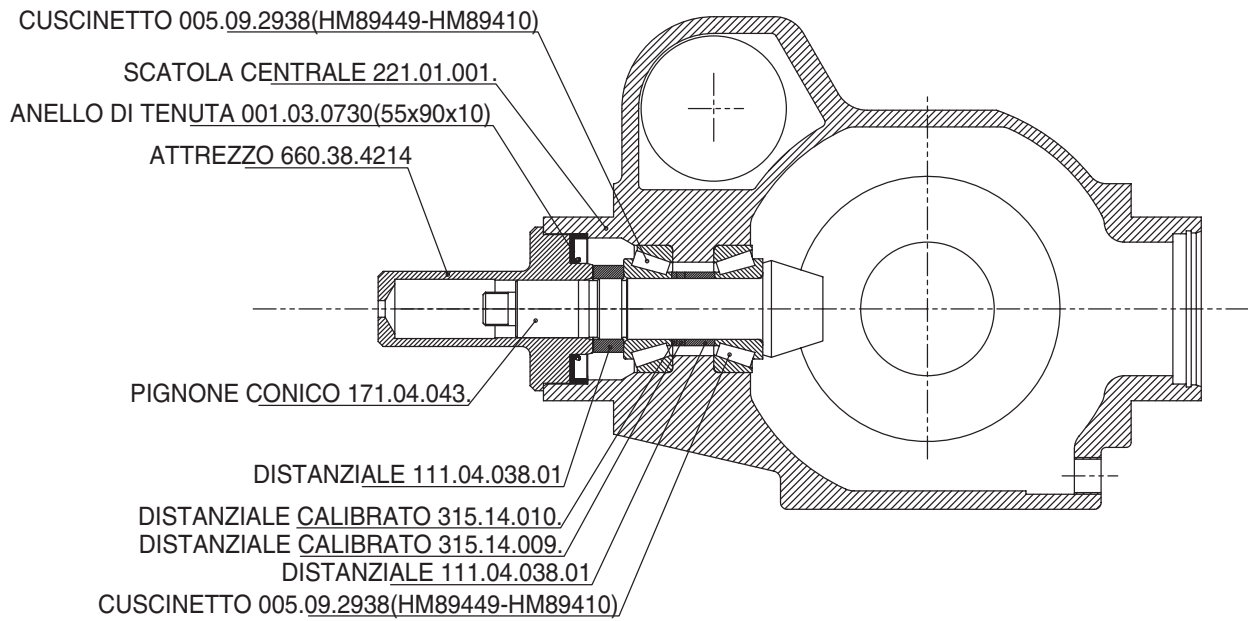

T12

4215

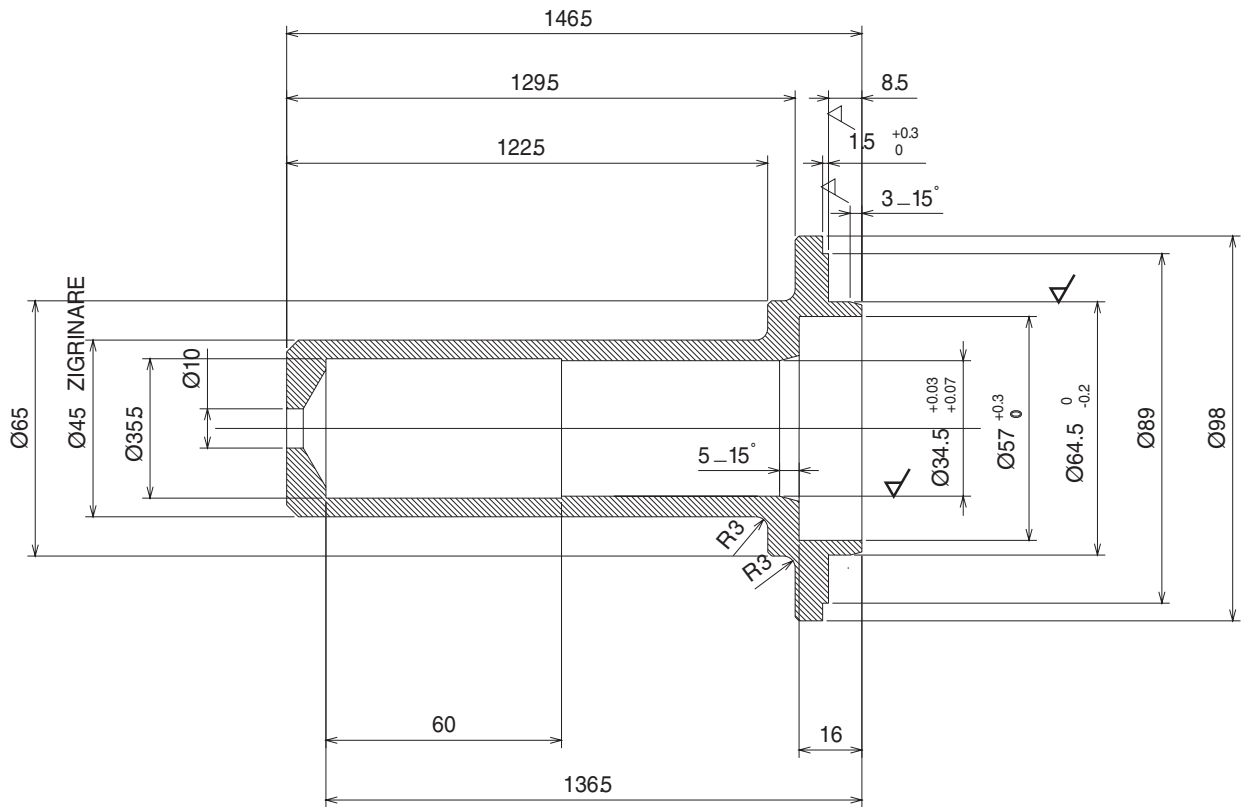

55W77FA512

T13

4209

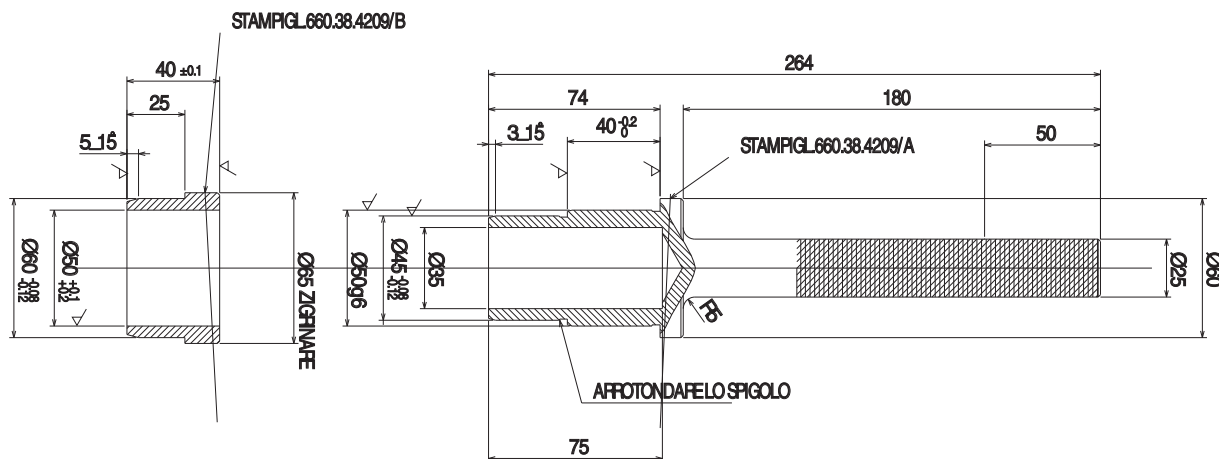

55W77FA513



T16

2767

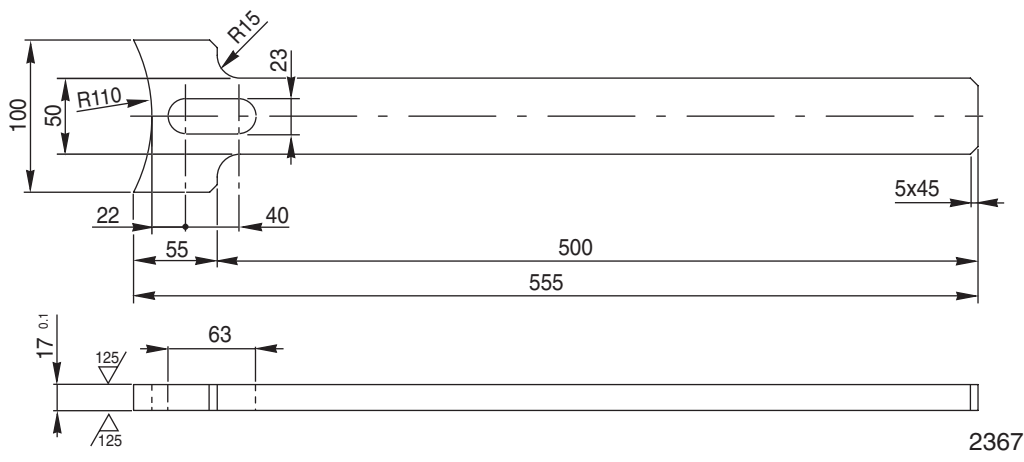

55W77FA516