

## GROUP 3 PUMP DEVICE

### 1. REMOVAL AND INSTALL

#### 1) REMOVAL

- (1) Lower the work equipment to the ground and stop the engine.
- (2) Operate the control levers and pedals several times to release the remaining pressure in the hydraulic piping
- (3) Loosen the breather slowly to release the pressure inside the hydraulic tank.

▲ **Escaping fluid under pressure can penetrate the skin causing serious injury.**

- (4) Loosen the drain plug under the hydraulic tank and drain the oil from the hydraulic tank.

· Hydraulic tank quantity : 70 l  
(18.5 U.S.gal)

- (5) Disconnect hydraulic hoses(22, 64, 65).
- (6) Remove socket bolts(83) and disconnect pump suction pipe(10).
- (7) Sling the pump assembly and remove the pump mounting bolts.

· Weight : 30kg(70lb)

※ **Pull out the pump assembly from housing.**

**When removing the pump assembly, check that all the hoses have been disconnected.**

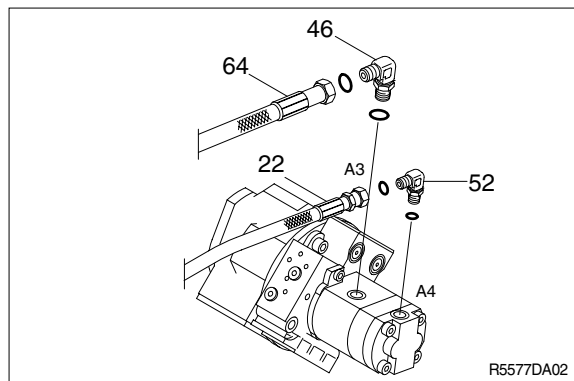
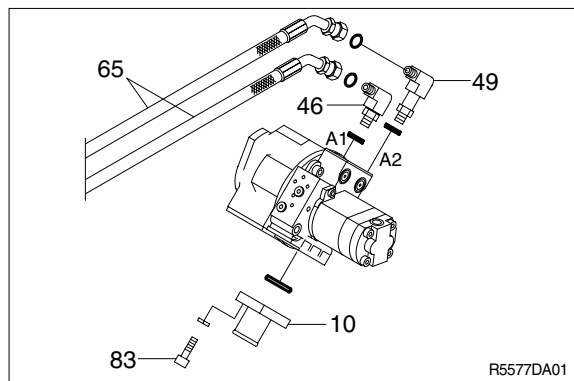

## 2) INSTALL

- (1) Carry out installation in the reverse order to removal.
- (2) Remove the suction strainer and clean it.
- (3) Replace return filter with new one.
- (4) Remove breather and clean it.
- (5) After adding oil to the hydraulic tank to the specified level.
- (6) Bleed the air from the hydraulic pump.
  - ① Loosen the air vent plug.
  - ② Start the engine, run at low idling, and check oil come out from plug.
  - ③ Tighten plug.
- (7) Start the engine, run at low idling(3~5 minutes) to circulate the oil through the system.
- (8) Confirm the hydraulic oil level and check the hydraulic oil leak or not.

## 2. MAIN PUMP

### 1) STRUCTURE

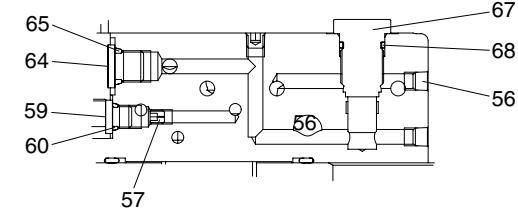
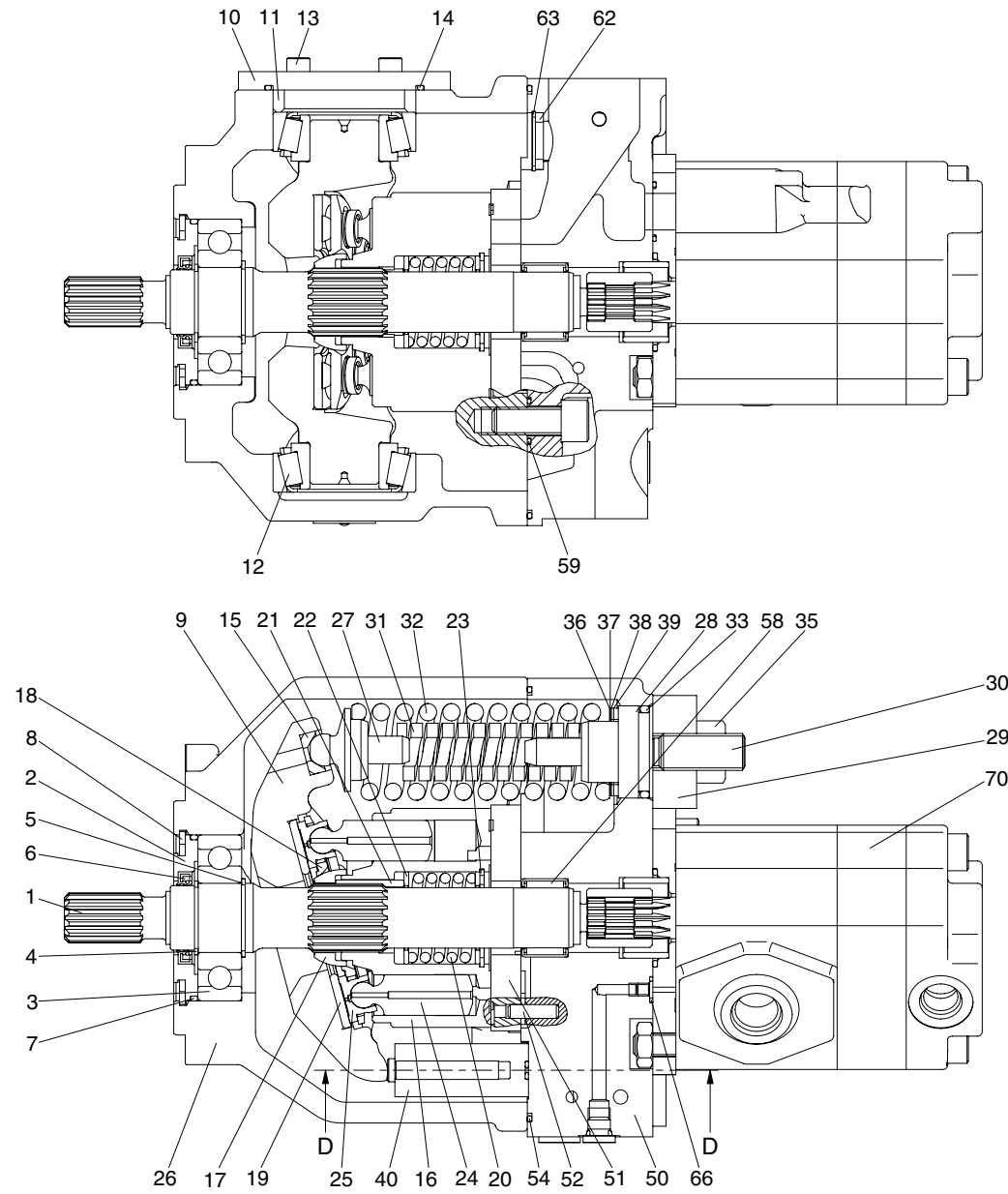

SECTION C-C

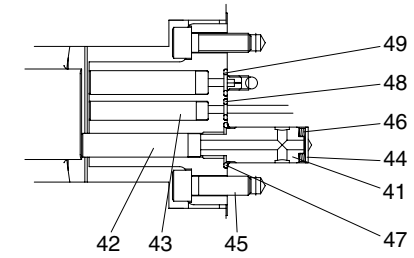

SECTION D-D

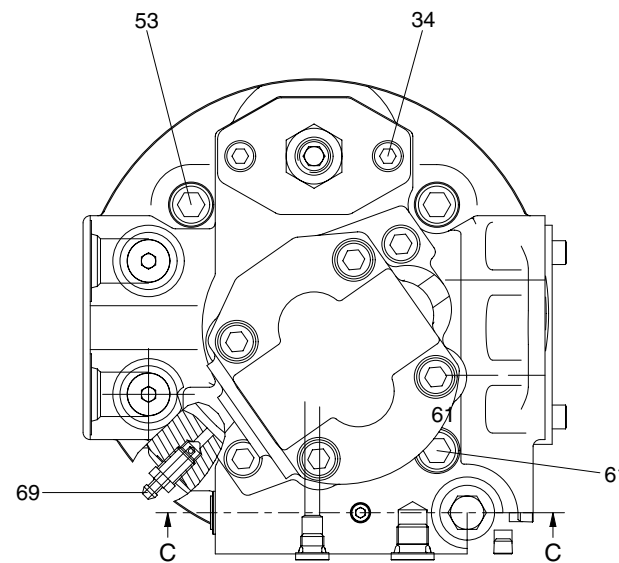

1 Drive shaft	13 Socket bolt	25 Shoe	37 Shim	49 O-ring	61 Socket bolt
2 Seal cover	14 O-ring	26 Pump casing	38 Shim	50 Valve block	62 Filter
3 Ball bearing	15 Pivot	27 Spring seat(1)	39 Shim	51 Valve plate	63 Snap ring
4 Snap ring	16 Cylinder block	28 Spring seat(2)	40 Control cylinder	52 Parallel pin	64 RO plug
5 Snap ring	17 Spherical bush	29 Spring cover	41 Control piston	53 Socket bolt	65 O-ring
6 Oil seal	18 Push plate	30 Adjusting screw	42 Control push-rod(1)	54 O-ring	66 O-ring
7 O-ring	19 Shoe plate	31 Spring	43 Control push-rod(2)	55 O-ring	67 Plug
8 Snap ring	20 Spring	32 Spring	44 Spring seat(1)	56 Plug	68 O-ring
9 Swash plate	21 Parallel pin	33 O-ring	45 Socket bolt	57 Orifice	69 Air breather
10 Plate	22 Spring seat	34 Socket bolt	46 Conical spring washer	58 Needle bearing	70 Gear pump assy
11 Bearing spacer	23 Snap ring	35 Hex nut	47 O-ring	59 RO plug	
12 Roller bearing	24 Piston	36 Shim	48 O-ring	60 O-ring	

55W77MP06

## 2) TOOLS AND TIGHTENING TORQUE

### (1) Tools

The tools necessary to disassemble/reassemble the pump are shown in the follow list.

Name	Quantity	Size (Nominal)
Hexagonal bar spanner	One each	5, 6, 8, 10
Spanner	1	17, 24
Plastic hammer	1	Medium size
Snap ring pliers	1	For hole (Stop ring for 72)
Snap ring pliers	1	For shaft (Stop rings for 28 and 30)
Standard screw-driver	2	Medium size
Torque wrench	-	Wrench which can tighten at the specified torque
Grease	Small	-
Adhesives	Small	LOCTITE #270

### (2) Jigs

#### ① Disassembling table.

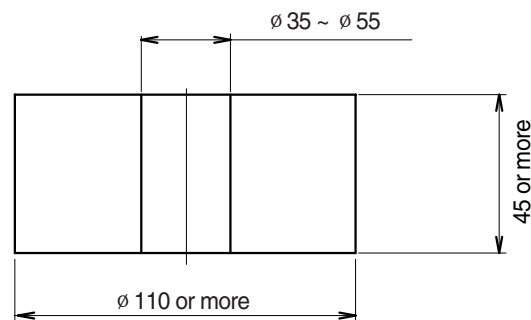

R55NM7HP01

This is plate to stand the pump facing downward.

A square block may be used instead if the shaft end does not contact.

#### ② Bearing assembling jig

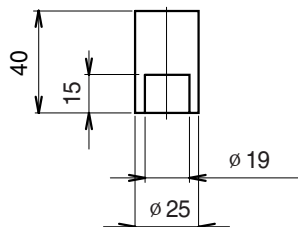

R55NM7HP02

### (3) Tightening torque

Part name	Bolt size	Torque		Wrench size	
		kgf · m	lbf · ft	in	mm
Hexagon socket head bolt	M 6	1.2	8.7	0.20	5
	M 8	3.0	21.7	0.24	6
	M12	10.0	72.3	0.39	10
	M16	24.0	174	0.55	14
	M18	34.0	246	0.55	14
PT Plug	PT 1/16	0.9	6.5	0.16	4
PF Plug	PF 1/8	1.5	10.8	0.20	5
	PF 1/4	3.0	21.7	0.24	6

### 3. DISASSEMBLY PROCEDURE

#### 1) DISASSEMBLING THE GEARED PUMP

- ① Remove the hexagonal socket headed bolts (M10 × 25, 2 pieces).

Hexagonal bar spanner  
(Hex. side distance : 8)

- ※ Be careful because the O-ring and filter are provided to the match surface of the geared pump.



R55NM7HP03

- ② Remove the coupling.

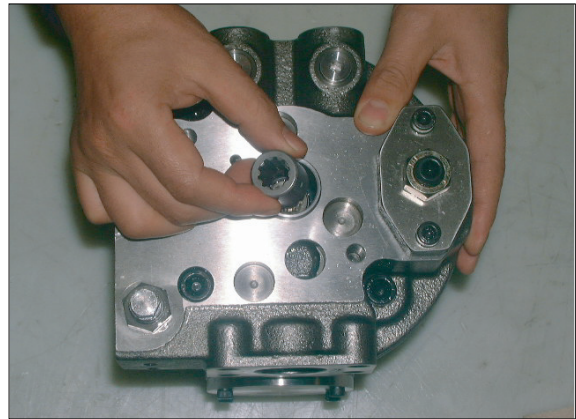

R55NM7HP04

#### 2) DISASSEMBLING THE MAIN PUMP

- ① Remove the cover.

Remove the hexagonal socket headed bolts. (M12 × 30, 3pieces) and (M12 × 55, 1piece).

Hexagonal bar spanner  
(Hex. side distance : 10)

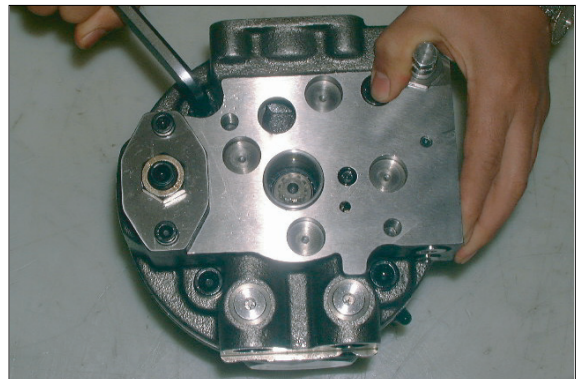

R55NM7HP05

- ② Remove the cover in a horizontal condition.

Connect motor to work table.

- ※ Be careful because the control plate is provided to the backside.  
When the cover is difficult to remove, knock lightly with a plastic hammer.

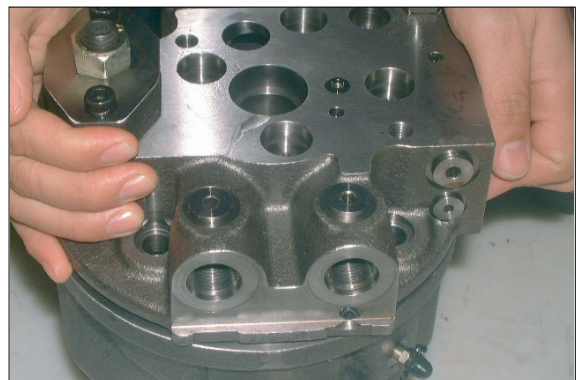

R55NM7HP06

- ③ This photo shows the state with the cover removed.

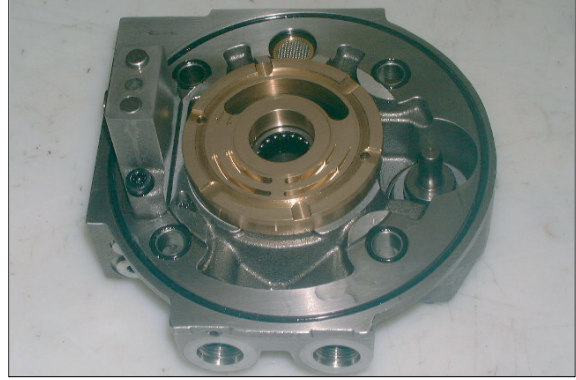

R55NM7HP07

- ④ Remove the O-ring from the cover.

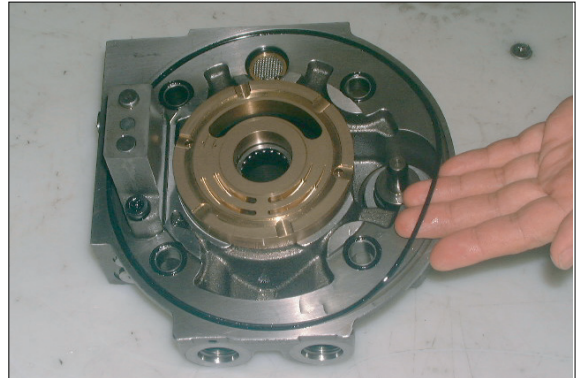

R55NM7HP08

**(1) The removal of the control spring**

- ① Remove 2 springs(Inner and outer).

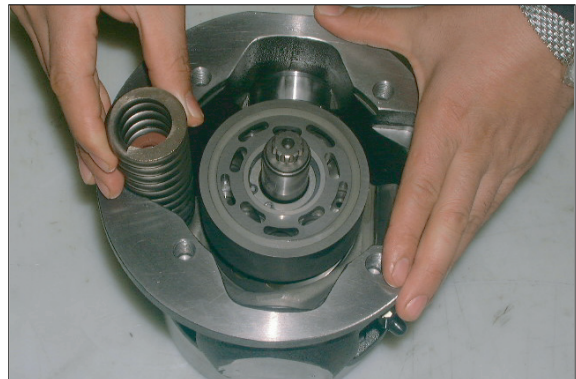

R55NM7HP09

- ② Remove the spring seat.

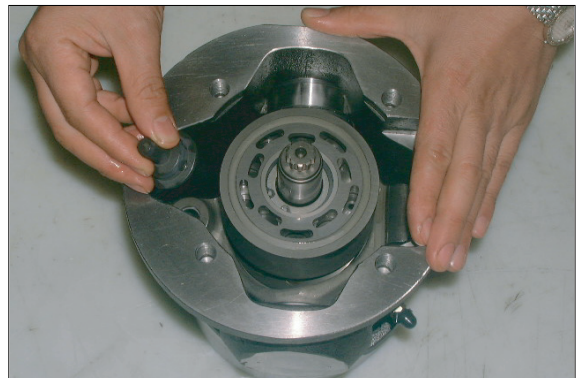

R55NM7HP10

**(2) The removal of rotary group**

- ① Lay the pump on the side and take out the rotary group from the shaft.

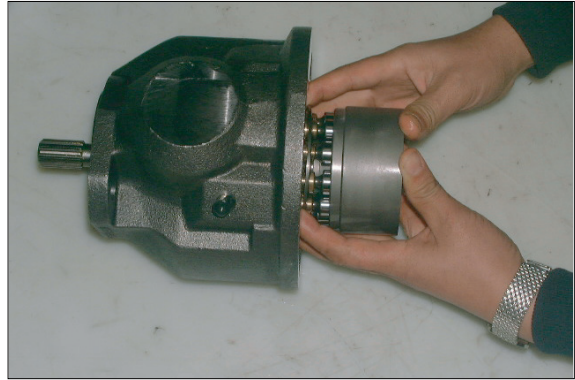

R55NM7HP11

- ② Remove the plate.



R55NM7HP12

**(3) The removal of the shaft**

- ① Remove the C-type stop ring.  
(Snap ring pliers for hole)

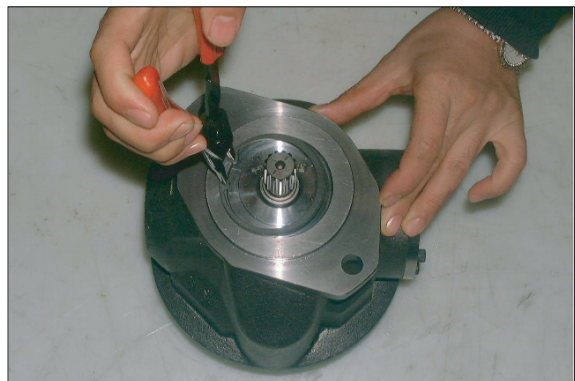

R55NM7HP13

- ② Use two standard screw-drivers to remove the oil seal case.

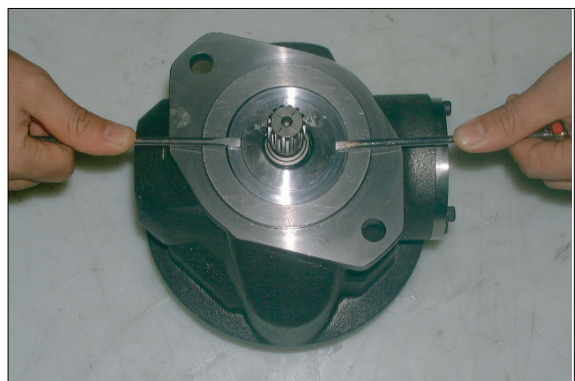

R55NM7HP14

- ③ Remove the O-ring.

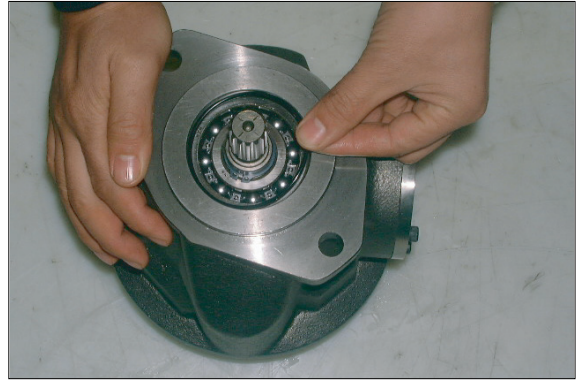

R55NM7HP15

- ④ Remove it while knocking the shaft rear and lightly with a plastic hammer.

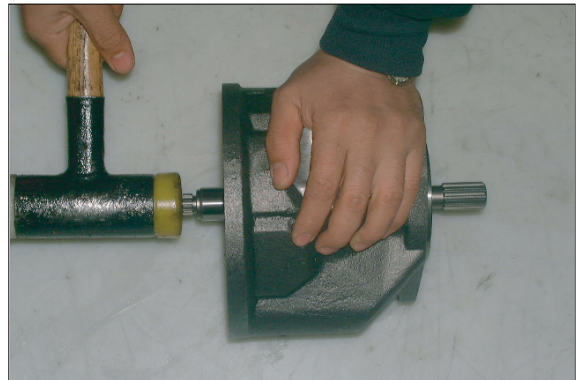

R55NM7HP16

#### (4) The removal of the hanger

- ① Remove the hexagonal socket headed bolts (M6 × 16, 4pieces) and plate.  
Hexagonal bar spanner  
(Hex. side distance : 5)

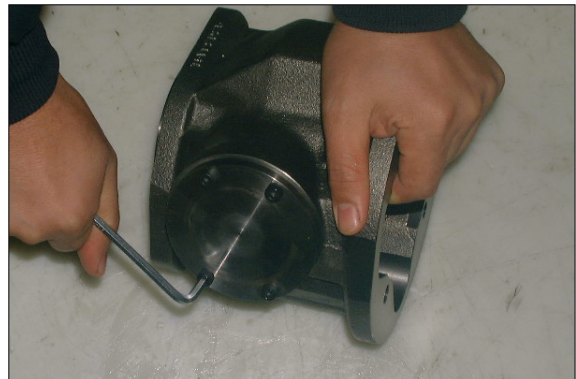

R55NM7HP17

- ② Remove the distance piece.



R55NM7HP18

③ Remove the bearing.

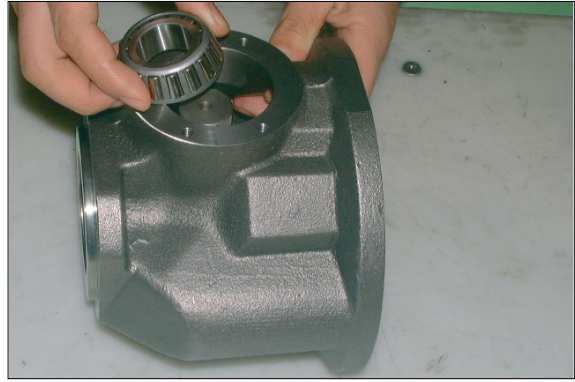

R55NM7HP19

④ Remove the hanger.

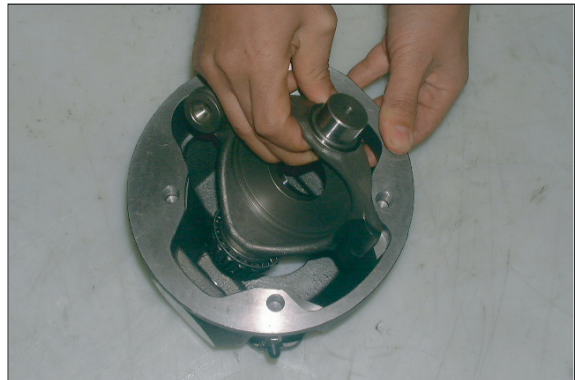

R55NM7HP20

**(5) The removal of the cover**

① Remove the control plate.

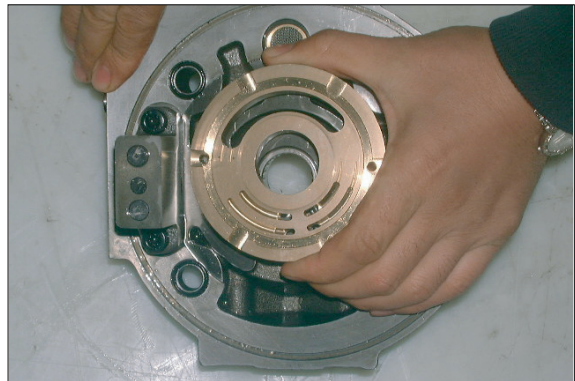

R55NM7HP21

② Remove the C-type stop ring.

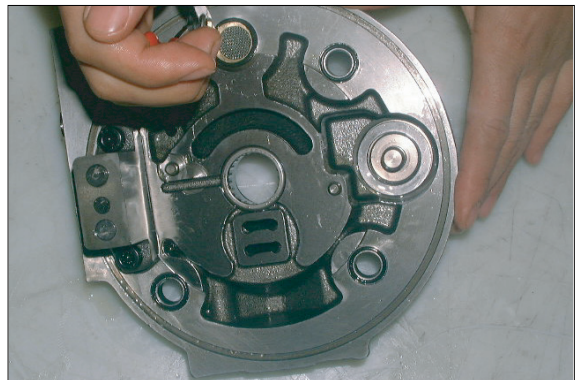

R55NM7HP22

- ③ Remove the filter.

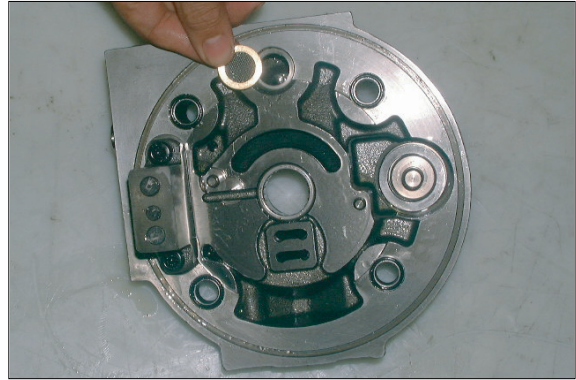

R55NM7HP23

**(6) The removal of the control piston**

- ① Remove the hexagonal socket headed bolts. (M8 × 25, 2pieces)  
Hexagonal bar spanner  
(Hex. side distance : 6)  
The threaded portion of the bolt is coated with LOCTITE #270.  
This disassembly must therefore be made only when necessary.

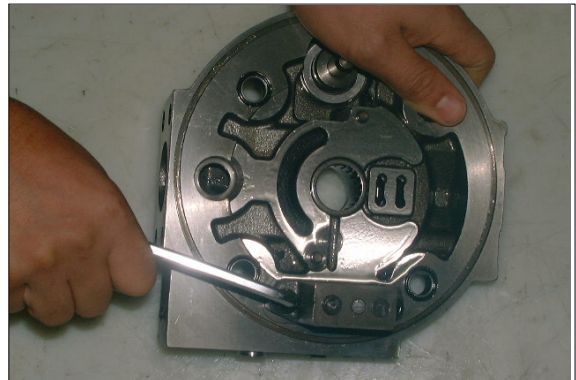

R55NM7HP24

- ② Remove the cylinder and parallel pin.  
※ Be careful because 3 O-rings are provided to the cylinder.

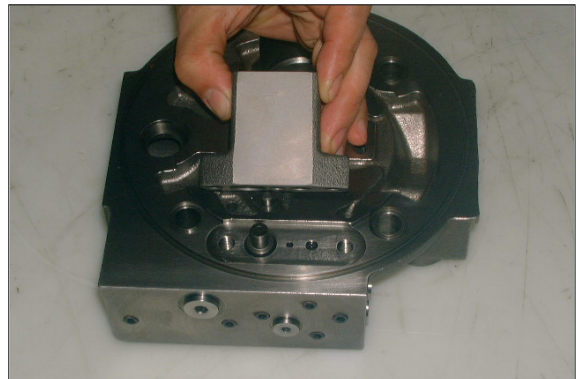

R55NM7HP25

- ③ Take out the piston.

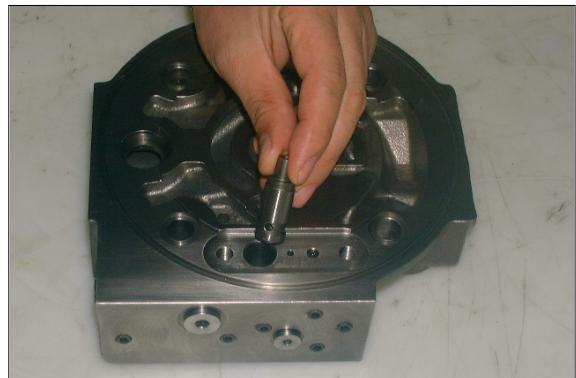

R55NM7HP26

- ④ Take out three caned disk springs and spring seats.

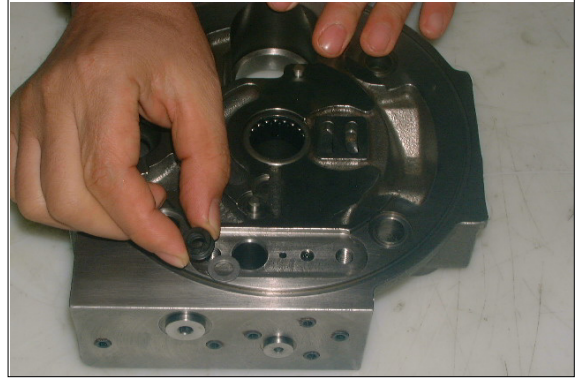

R55NM7HP27

**(7) The removal of the control spring**

- ① Remove the hexagonal socket headed bolts (M8 × 30, 2pieces) and remove the cover.

Hexagonal bar spanner  
(Hex. side distance : 6).

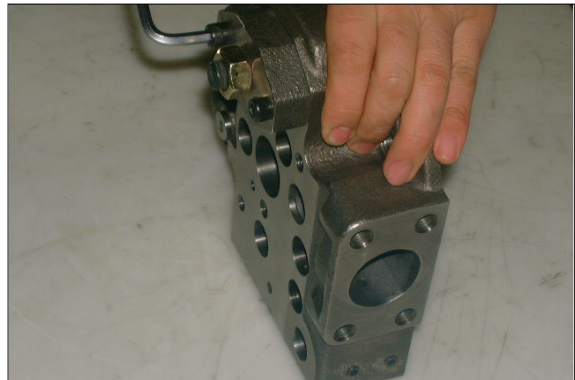

R55NM7HP28

- ② Remove the spring seat.

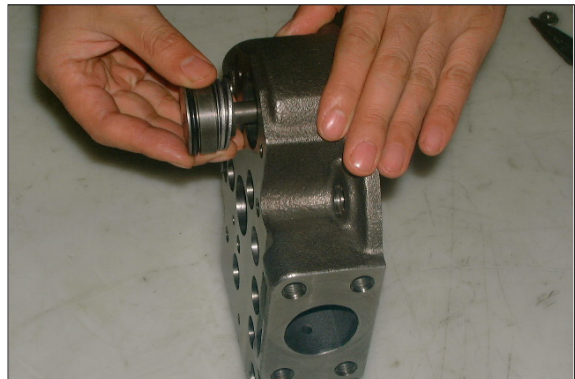

R55NM7HP29

**(8) The removal of the relief valve**

- ① Remove the hexagonal nuts.
- ※ Since the pressure has been set, this assembly must be made only when necessary.
- Spanner (Hex. side distance : 24).

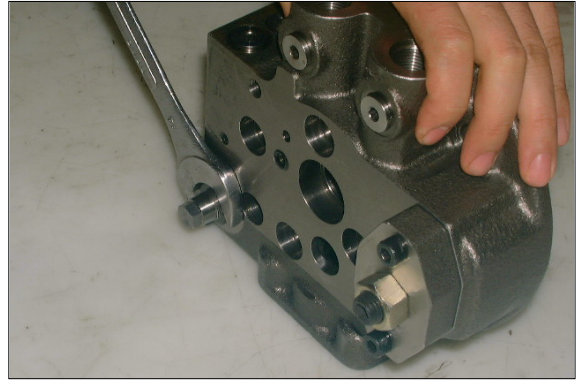

R55NM7HP30

- ② Remove the adjusting screw.
- ※ Be careful because the shim is inserted.

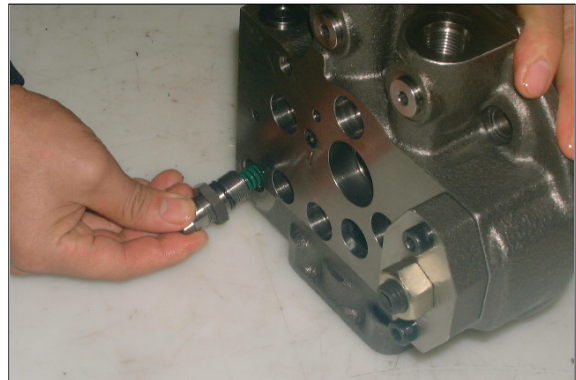

R55NM7HP31

- ③ Remove the spring.

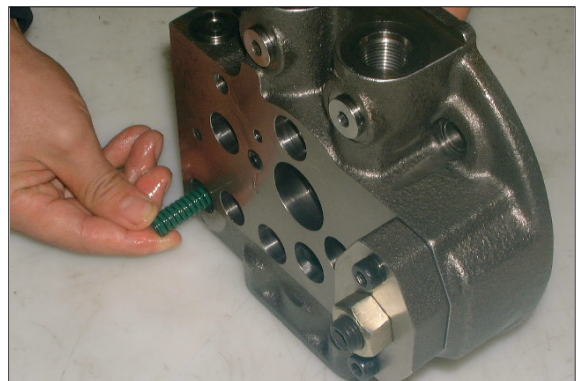

R55NM7HP32

- ④ Remove the spool.

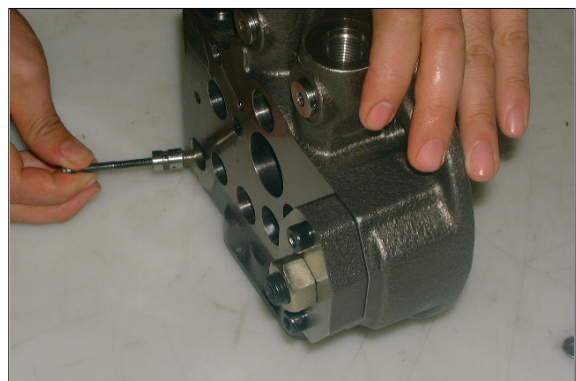

R55NM7HP33

**(9) Disassembly of the shaft**

- ① Remove the bearing.  
Remove the C-type stop ring.  
Snap ring pliers for shaft.

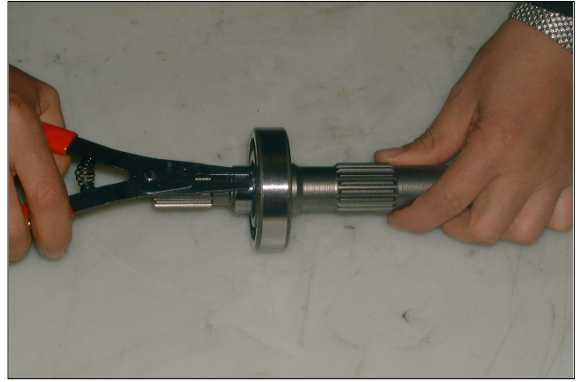

R55NM7HP34

- ② Remove it while knocking the rear end of shaft lightly with a plastic hammer.



R55NM7HP35

### 3) DISASSEMBLING THE GEARED PUMP

#### (1) Disassembling the P3 and P4 pump

- ① Removed hexagonal socket head bolt and nut.  
Hexagonal socket wrench(8mm).  
Hexagonal bar spanner(17mm).

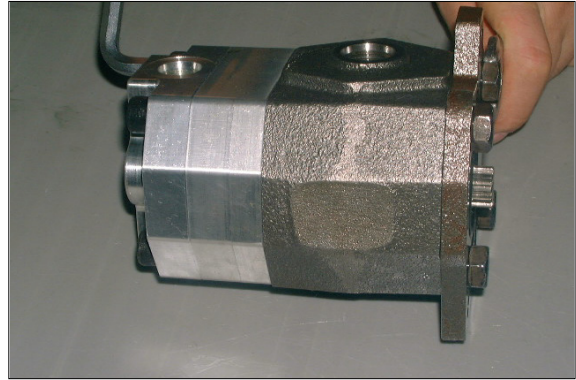

R55NM7HP209

#### (2) Disassembling the geared pump (P4)

- ① Remove the geared pump(P4) from the center frame.

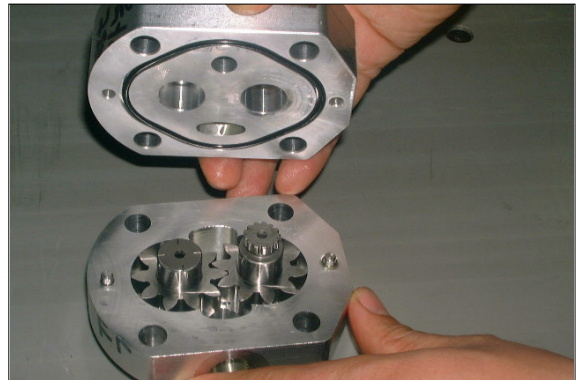

R55NM7HP208

- ② Pulling out the drive gear and the idle gear.

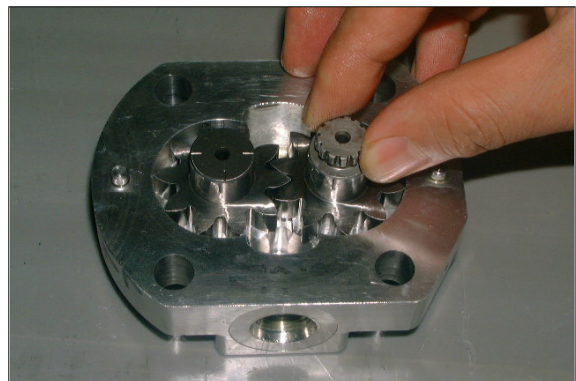

R55NM7HP207

- ③ Remove the O-ring from the center frame.

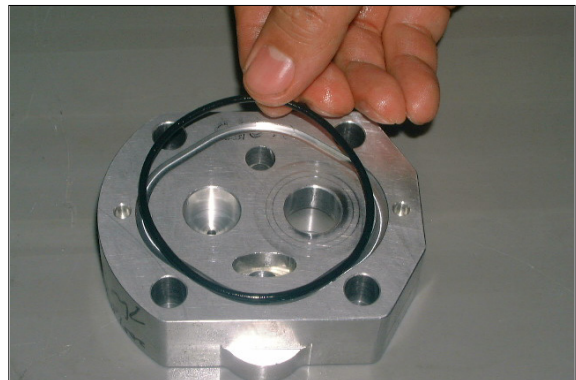

R55NM7HP206

**(3) Disassembling the geared pump (P3)**

- ① Remove the square ring(10).

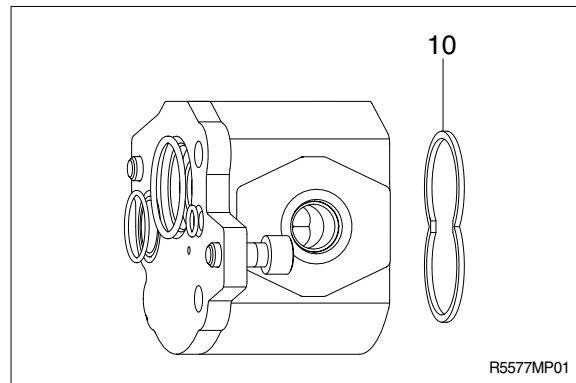

- ② Remove the plate(5) and the guide ring(pieces). With O-ring(6, 8).  
Remove the O-ring from guide ring.

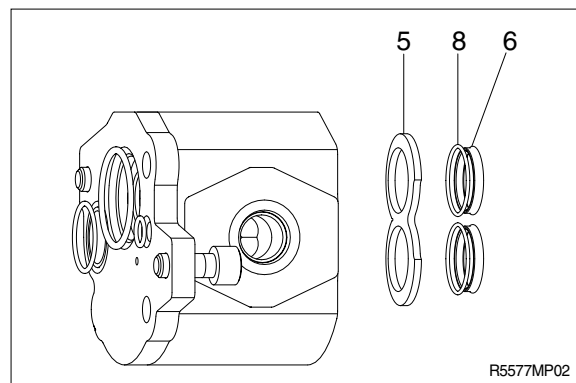

- ③ Remove the drive and driven gear(2, 3) and the side plate(4) assembly.

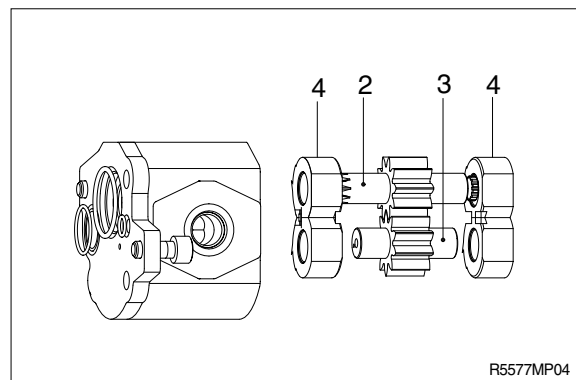

- ④ Remove the plate(5).

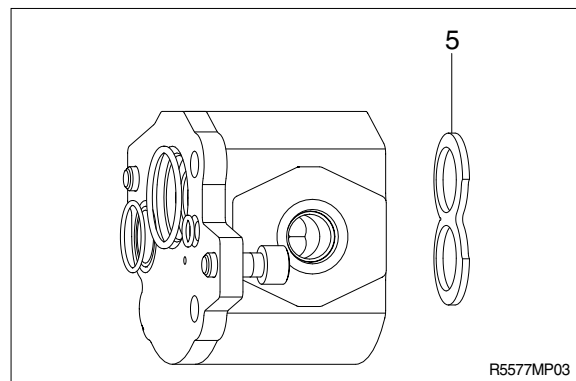

#### 4. ASSEMBLING PROCEDURE

##### 1) ASSEMBLING THE MAIN PUMP

(1) Assembling the hanger.

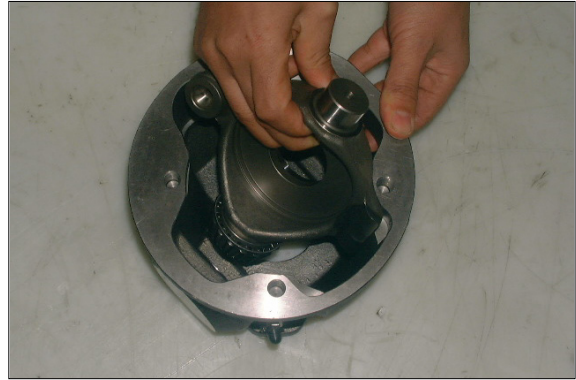

R55NM7HP50

(2) Install the bearing.



R55NM7HP50A

(3) Install the distance piece.  
Confirm that pre-load is  $0.1 \pm 0.2$ .

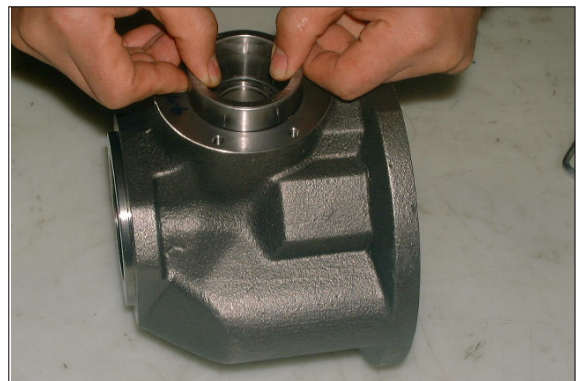

R55NM7HP51

(4) Fix the plate with the hexagonal socket headed bolts (M6 × 16, 4pieces).  
Hexagonal bar spanner  
(Hex. side distance : 5)  
Tightening torque : 1.2 ~ 1.5kgf · m  
(8.7 ~ 10.8lbf · ft)

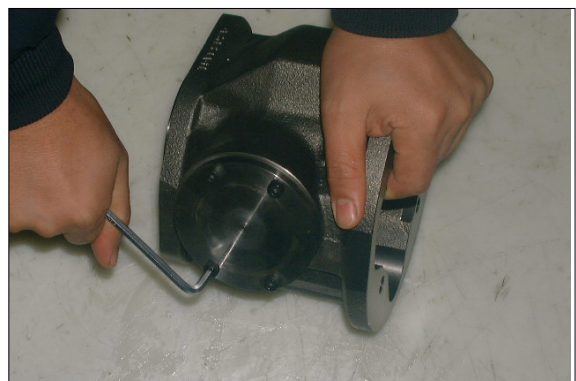

R55NM7HP52

(5) Assembling the shaft

- ① Fit the shaft into the bearing (With the bearing in the bottom) by using the press machine and jig. If the press is not available, use the jig in the similar manner and drive the shaft into the bearing by knocking with a plastic hammer.



R55NM7HP53

- ② Install the C-type stop ring to fix the bearing.

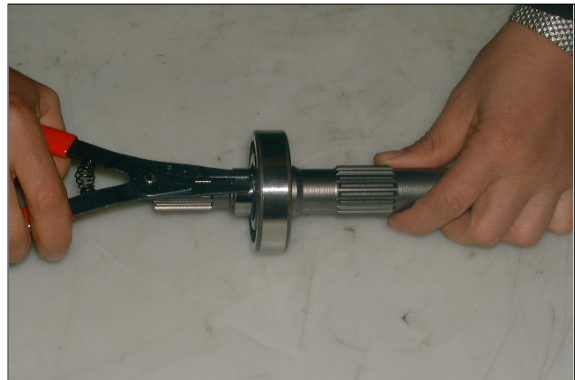

R55NM7HP54

- ③ Assembling the shaft.  
Assemble the shaft into the housing.  
Knock the spline end lightly with a plastic hammer and fix the bearing outer ring firmly into the housing hole.

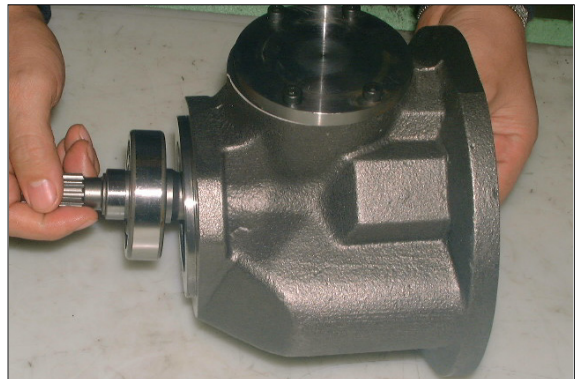

R55NM7HP55

- ⑥ Apply grease to the O-ring for assembling.

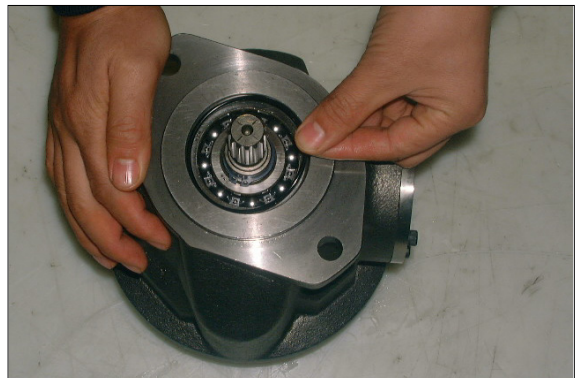

R55NM7HP56

- (7) Install the case with oil seal vertically without tilting.  
※ Apply grease to the oil seal lip beforehand.



R55NM7HP57

- (8) Install the C-type stop ring to fix the shaft.



R55NM7HP58

- (9) Assembling the rotary group.  
Install 10(ten) pistons into the retainer.

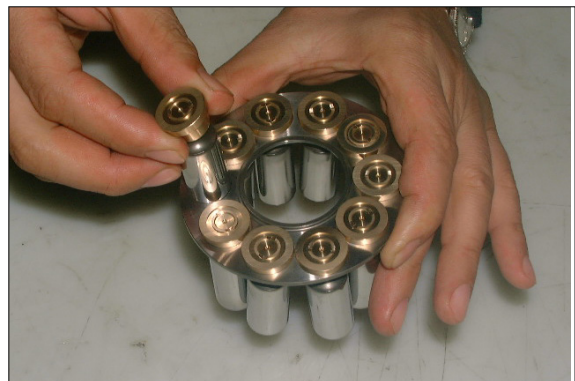

R55NM7HP59

- (10) Apply grease to 3 parallel pins and assemble them to the cylinder block.



R55NM7HP60

- (11) Apply grease to the spherical portion of the guide.

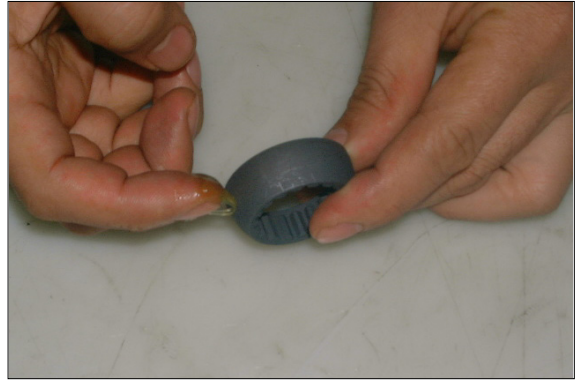

R55NM7HP61

- (12) Insert the guide between the retainer and cylinder block and assemble the piston into the hole of cylinder block.

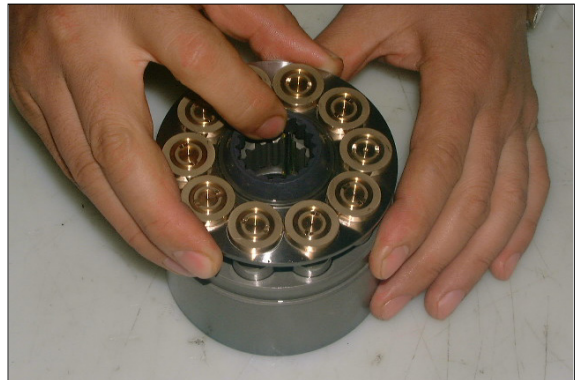

R55NM7HP62

- (13) Assembling the rotary group.  
To prevent dislodgement, apply grease to the back side of the plate and assemble it to the hanger.



R55NM7HP63

- (14) Assemble the rotary group along the shaft spline.  
※ During assembly, apply grease to the slide surface of piston shoe and to the slide surface of the cylinder block relative to the control plate.

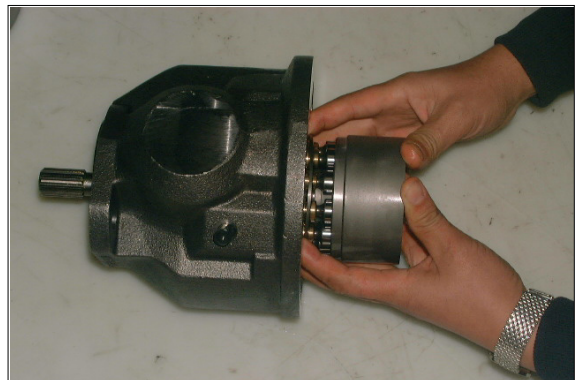

R55NM7HP64

- (15) Assembling the control spring.  
Apply grease to the spherical portion of the spring seat before assembling.

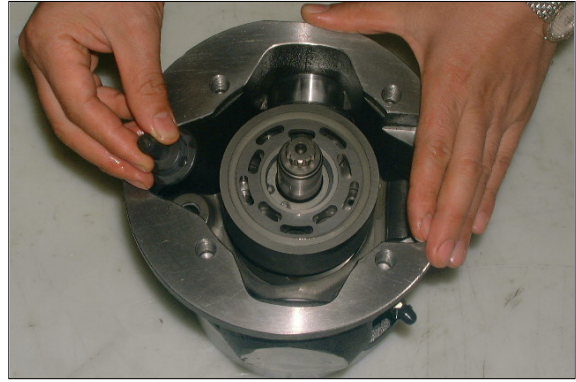

R55NM7HP65

- (16) Assemble 2 springs (Inner and outer).

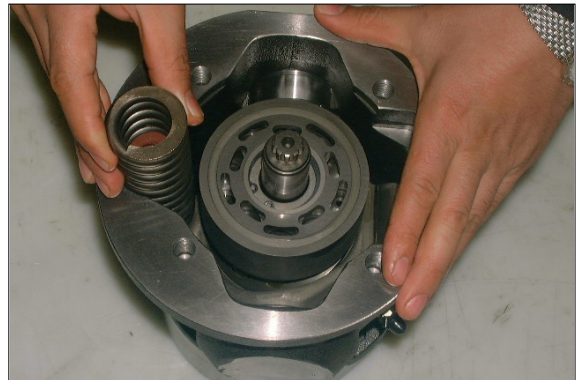

R55NM7HP66

- (17) Assembling the cover.  
Assemble the spring seats and coned disk springs (3 pieces).

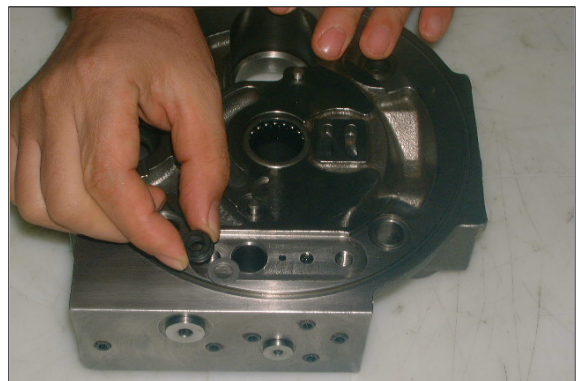

R55NM7HP67

- (18) Assembling the control piston.

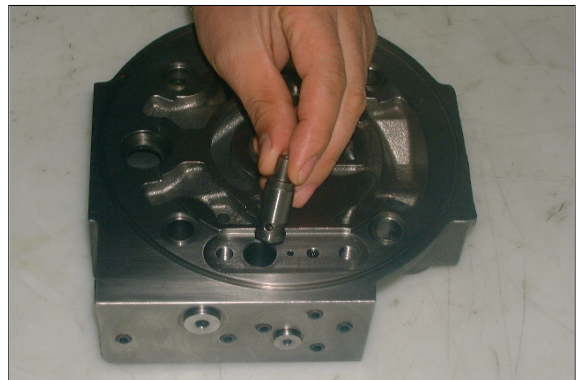

R55NM7HP68

- (19) Apply grease to the O-rings  
( $5.28 \times 1.78$ , 1piece), ( $7.65 \times 1.78$ , 1piece)  
and ( $15.6 \times 1.78$ , 1piece) and assemble  
them to the cylinder.

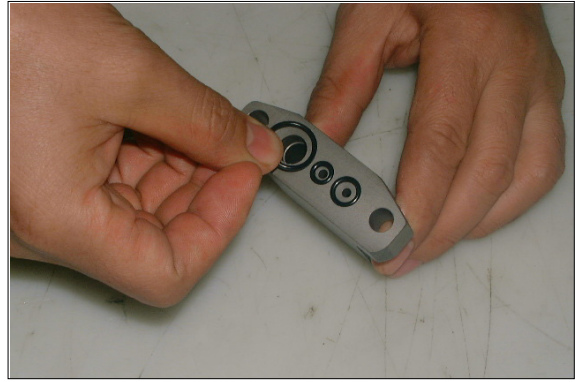

R55NM7HP69

- (20) Apply grease to 3 parallel pins and  
assemble 3 pins into the cylinder.

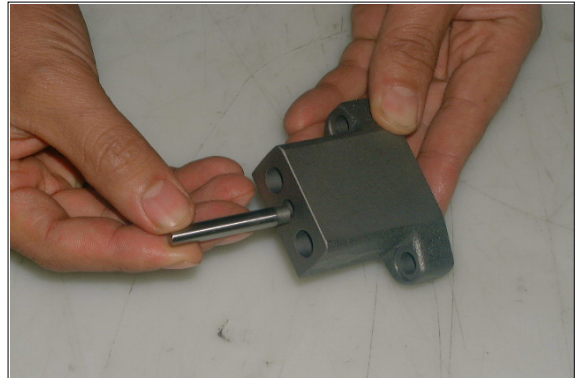

R55NM7HP70

- (21) Fix the cylinder with the hexagonal socket  
headed bolts ( $M8 \times 25$ , 2pieces).

※ Apply LOCTITE #270 to the threaded  
portion of bolt.

Hexagonal bar spanner

(Hex. side distance : 6)

Tightening torque :  $2.9 \sim 3.5 \text{kgf} \cdot \text{m}$

( $21 \sim 25.3 \text{lb} \cdot \text{ft}$ )

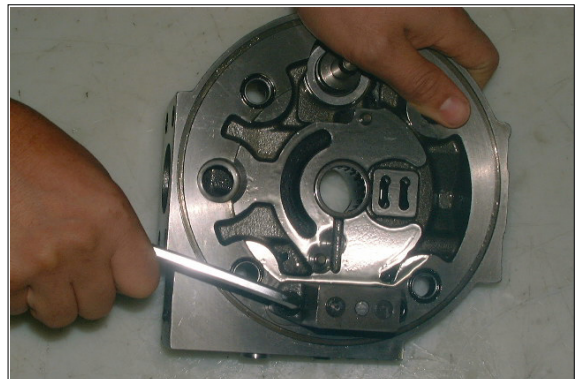

R55NM7HP71

- (22) Assembling the control spring.  
Install the spring seat.

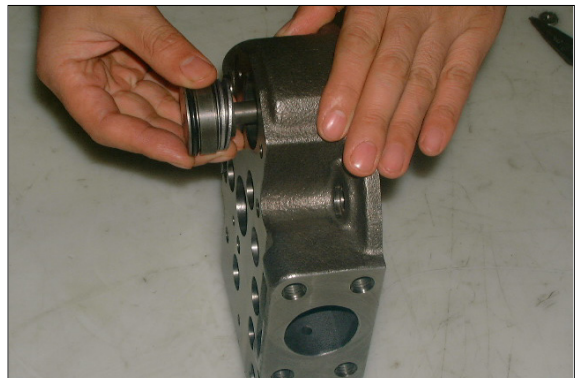

R55NM7HP72

- (23) Fix the cover with the hexagonal socket headed bolts (M8 × 30, 2pieces)  
Hexagonal bar spanner  
(Hex. side distance : 6)  
Tightening torque : 2.9 ~ 3.5kgf · m  
(21 ~ 25.3lbf · ft)

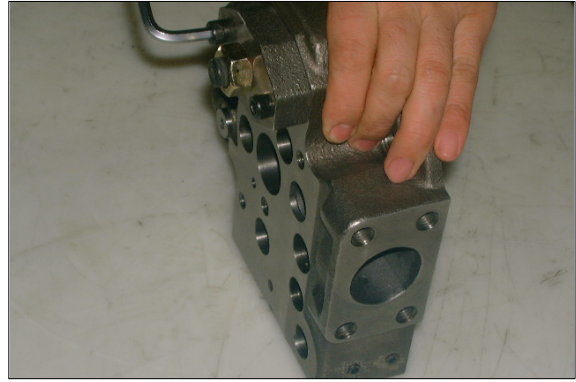

R55NM7HP73

- (24) Apply grease to the back side of the control plate and assemble it to the cover while matching knock holes.

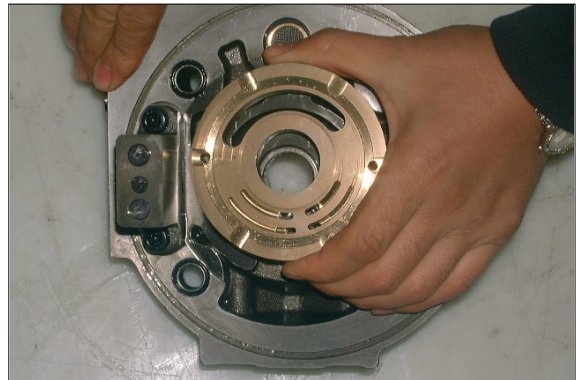

R55NM7HP74

- (25) Install the O-ring.  
Assemble the spring seats and coned disk springs (3pieces).

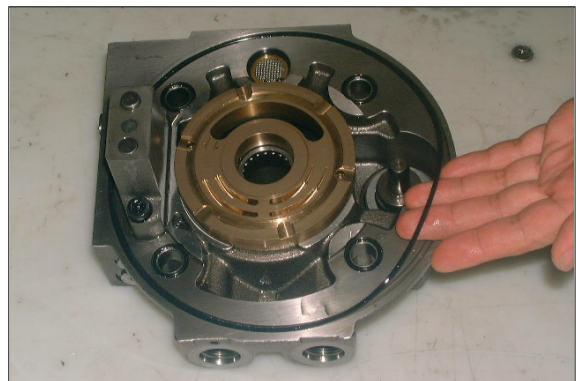

R55NM7HP75

- (26) Install the filter into the cover.

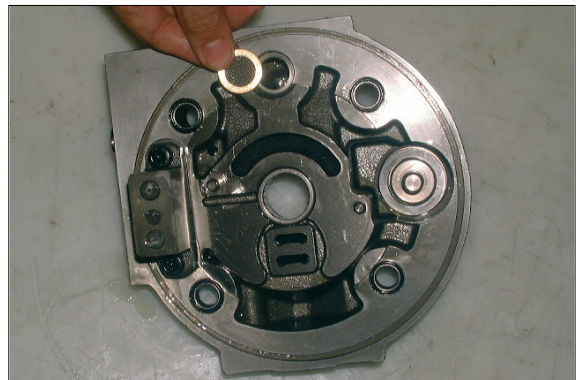

R55NM7HP76

(27) Fix the filter with the C-type stop ring.

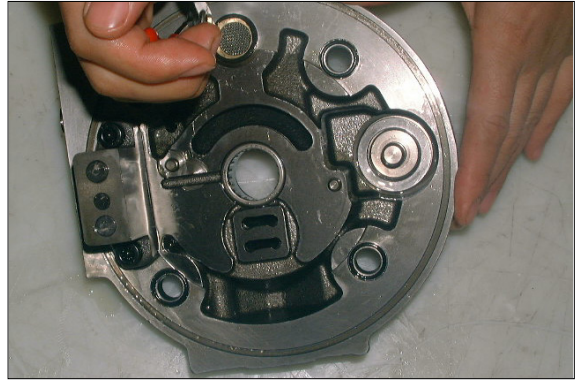

R55NM7HP77

(28) Assembling the relief valve.  
Assemble the spool.

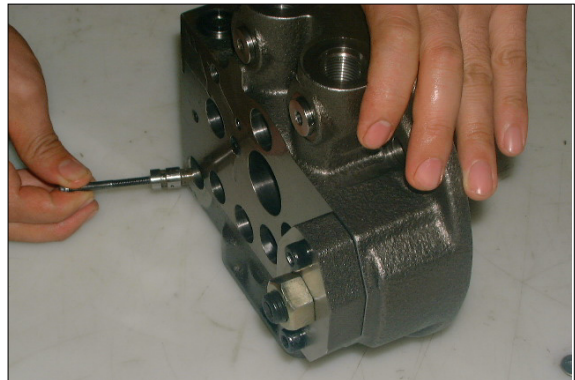

R55NM7HP78

(29) Assemble the spring.

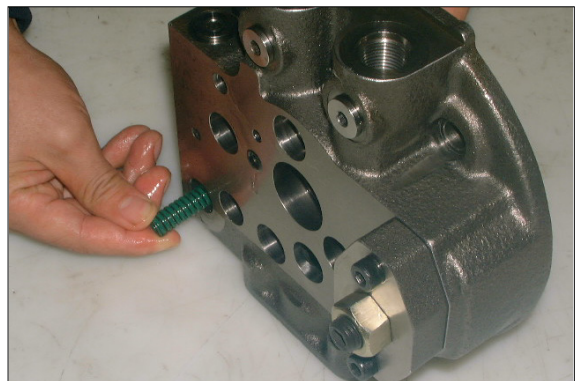

R55NM7HP79

(30) Insert the shim into the adjusting screw.



R55NM7HP80

(31) Assemble the adjusting screw.

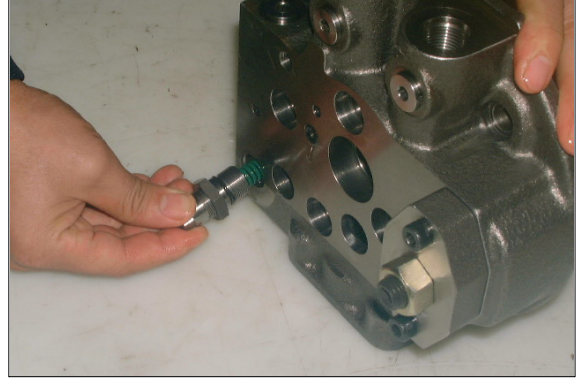

R55NM7HP81

(32) Tighten the hexagonal nuts.  
After assembling, set the pressure and  
tighten the nuts.  
1kgf · m(7.2lbf · ft)  
Spanner (Hex. side distance : 24)

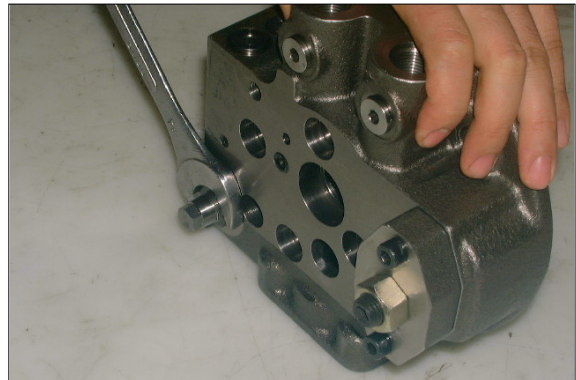

R55NM7HP82

(33) Install the cover in a parallel direction to  
the housing mounting surface.

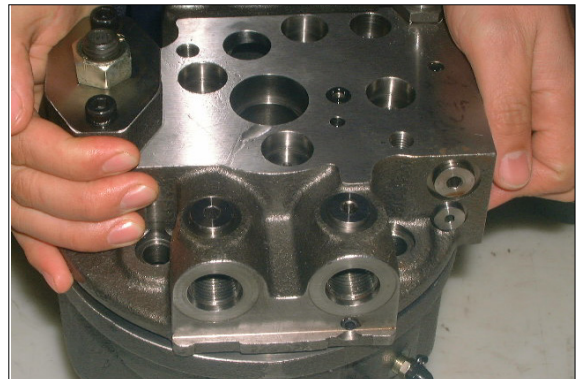

R55NM7HP83

(34) Fix the cover with the hexagonal socket  
headed bolts (M12×30, 3pieces) and  
(M12×55, 1piece)  
Hexagonal bar spanner  
(Hex. side distance :10)  
Tightening torque : 10 ~ 12.5kgf · m  
(72.3 ~ 90.4lbf · ft)

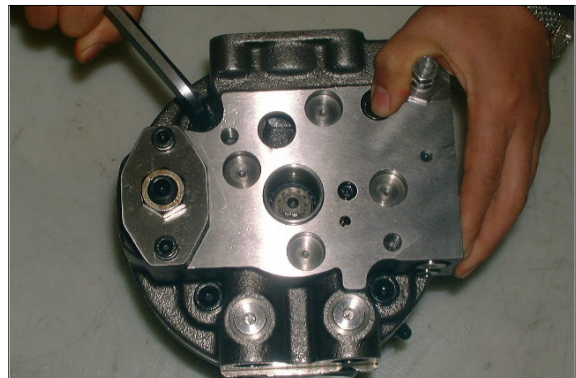

R55NM7HP84

(35) Install the O-ring into the cover.



R55NM7HP85

(36) Install the coupling to the shaft end of the main pump.

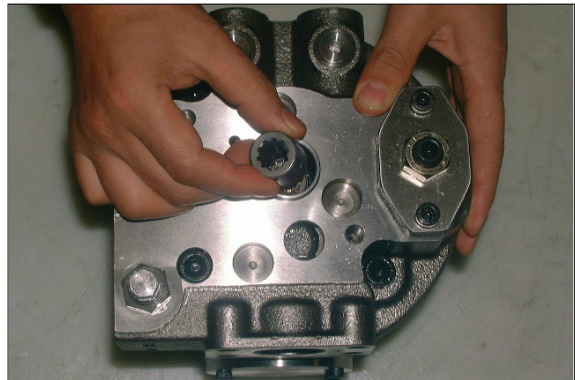

R55NM7HP86

(37) Connect the main and geared pump.



R55NM7HP87

(38) Fix the geared pump with the hexagonal socket headed bolts (M10 × 25, 2pieces).  
Hexagonal bar spanner  
(Hex. side distance : 8)  
Tightening torque : 5.6 ~ 7.0kgf · m  
(40.5 ~ 50.6lbf · ft)



R55NM7HP88

#### 4) REASSEMBLING THE GEARED PUMP

##### (1) Reassembling the geared pump (P3)

- ① Insert the plate(5) to the pump housing.

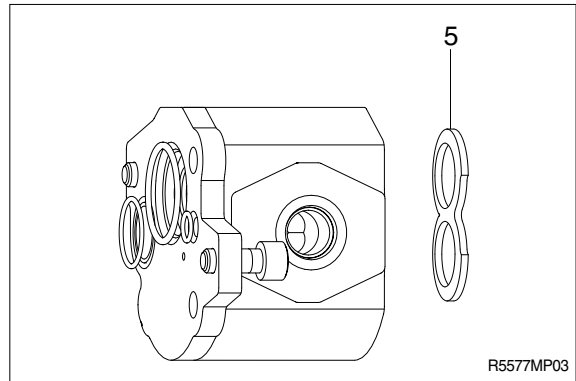

- ② Insert the square ring into the side plate.  
※ Be careful to suction and discharge side.

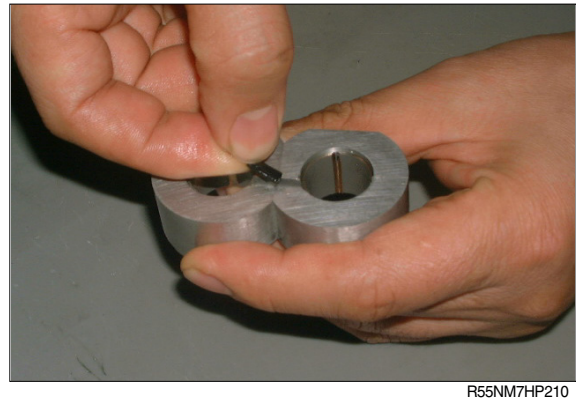

- ③ Assemble the side plate to the drive and idle gear.

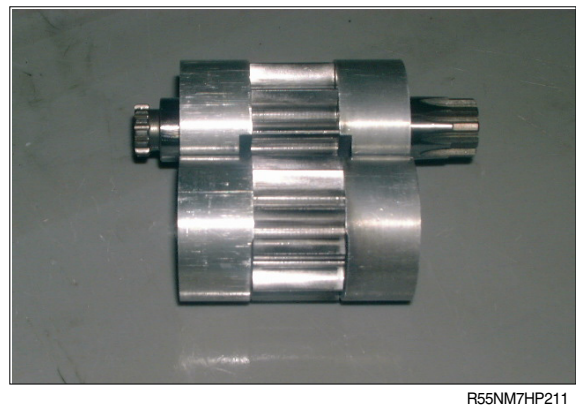

- ④ Assemble the gear assembly into the gear casing.

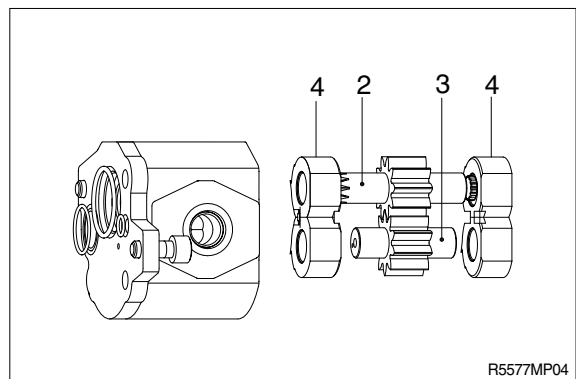

- ⑤ Assemble the O-ring to the guide ring and assemble them to the plate.



R55NM7HP213

- ⑥ Assemble the guide ring assembly(6, 8) and plate(5) to the gear casing.

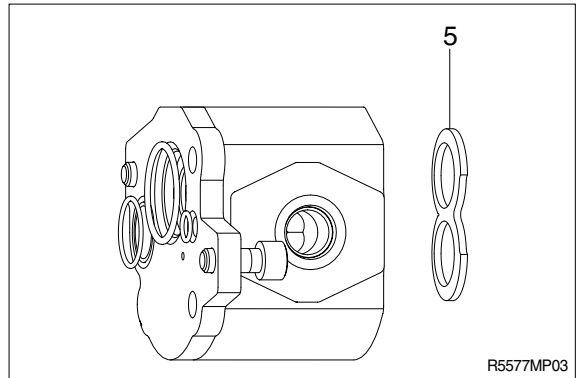

R5577MP03

- ⑦ Assemble the square ring(10) to the gear casing.

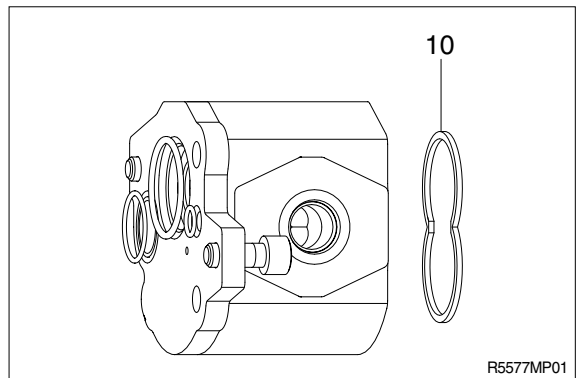

R5577MP01

**(2) Reassembling the geared pump (P4)**

- ① Insert the drive gear into the gear casing.

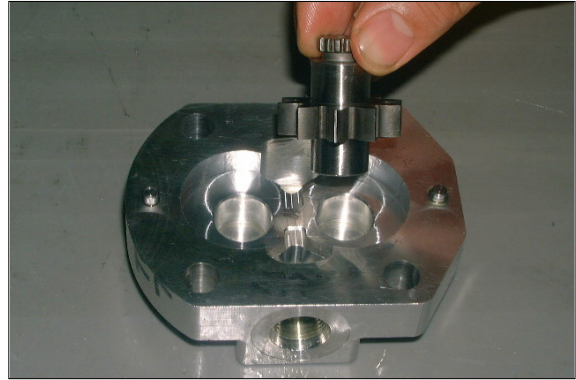

- ② Insert the idle gear to into the gear casing.

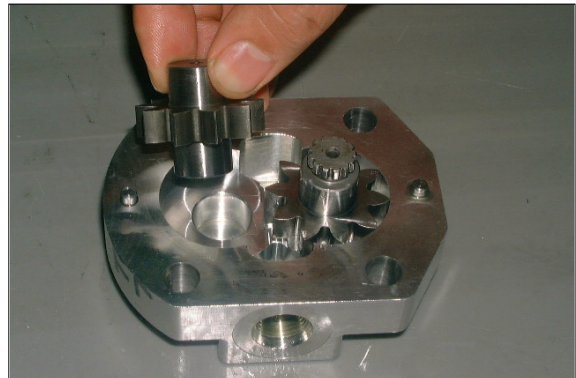

- ③ Insert the pins (2-pieces) to the center frame.

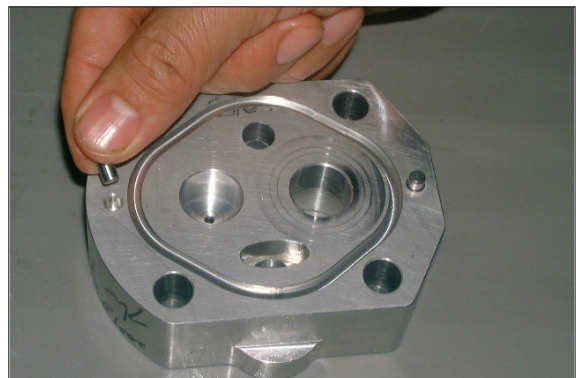

- ④ Assemble the O-ring to the center frame.

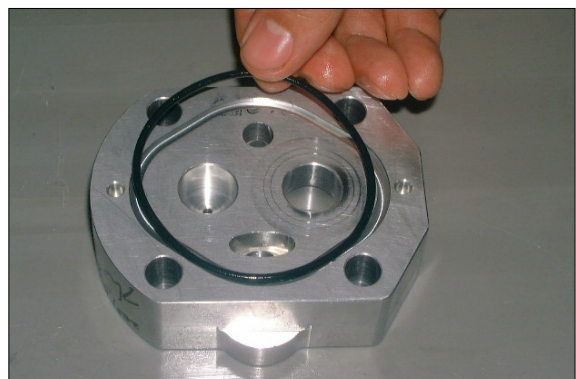

- ⑤ Assemble the center frame sub-assembly to the gear casing sub-assembly.

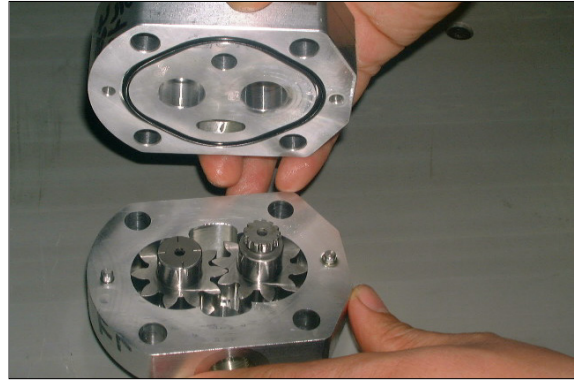

R55NM7HP223

**(3) Reassembling the P3 and P4 pumps**

- ① Insert the pins (2-pieces) into the center frame.

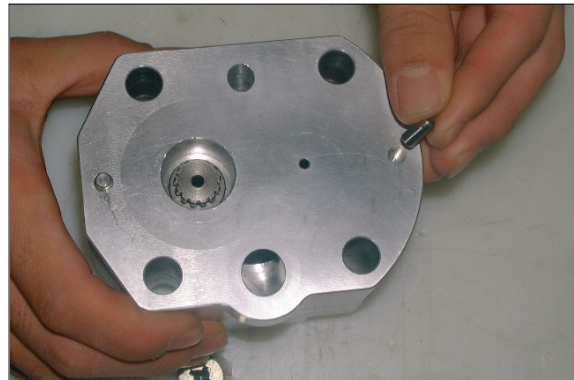

R55NM7HP224

- ② Insert coupling to the P3 geared pump.

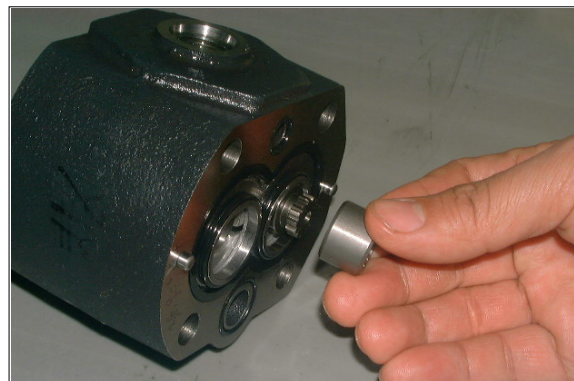

R55NM7HP225

- ③ Assemble the P3 and P4 geared pumps.

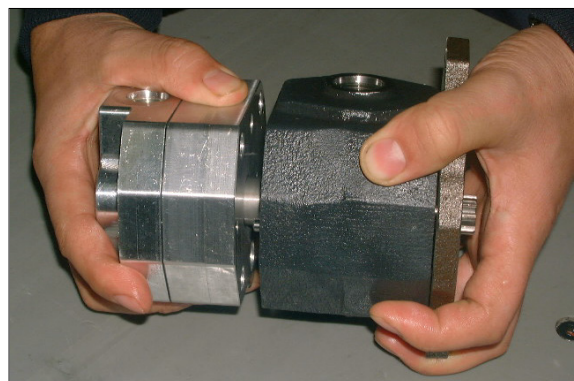

R55NM7HP226

④ Assemble the hexagonal socket bolts and nuts.

- Size : M10×65L, 4pieces
- Allen wrench : 8mm
- Spanner : 17mm
- Tightening torque : 580kgf · cm(56.9N · m)

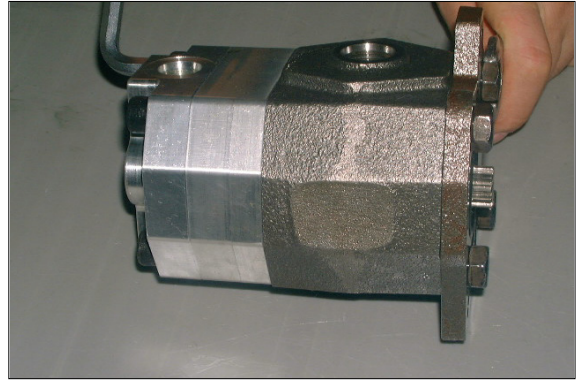

R55NM7HP227

⑤ Assemble the O-ring to the pump housing.

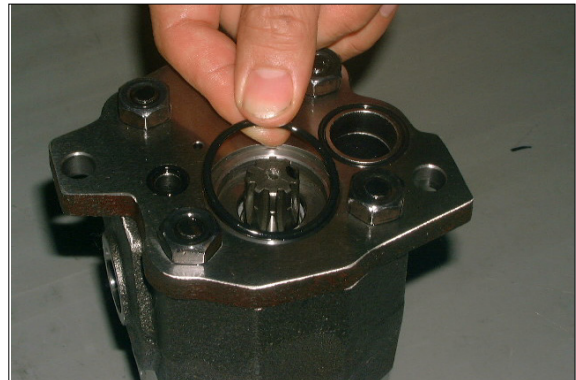

R55NM7HP228