

## GROUP 2 MONITORING SYSTEM

### 1. OUTLINE

Monitoring system consists of the monitor part and switch part.

The monitor part gives warnings when any abnormality occurs in the machine and informs the condition of the machine.

Various select switches are built into the monitor panel, which act as the control portion of the machine control system.

### 2. CLUSTER

#### 1) MONITOR PANEL

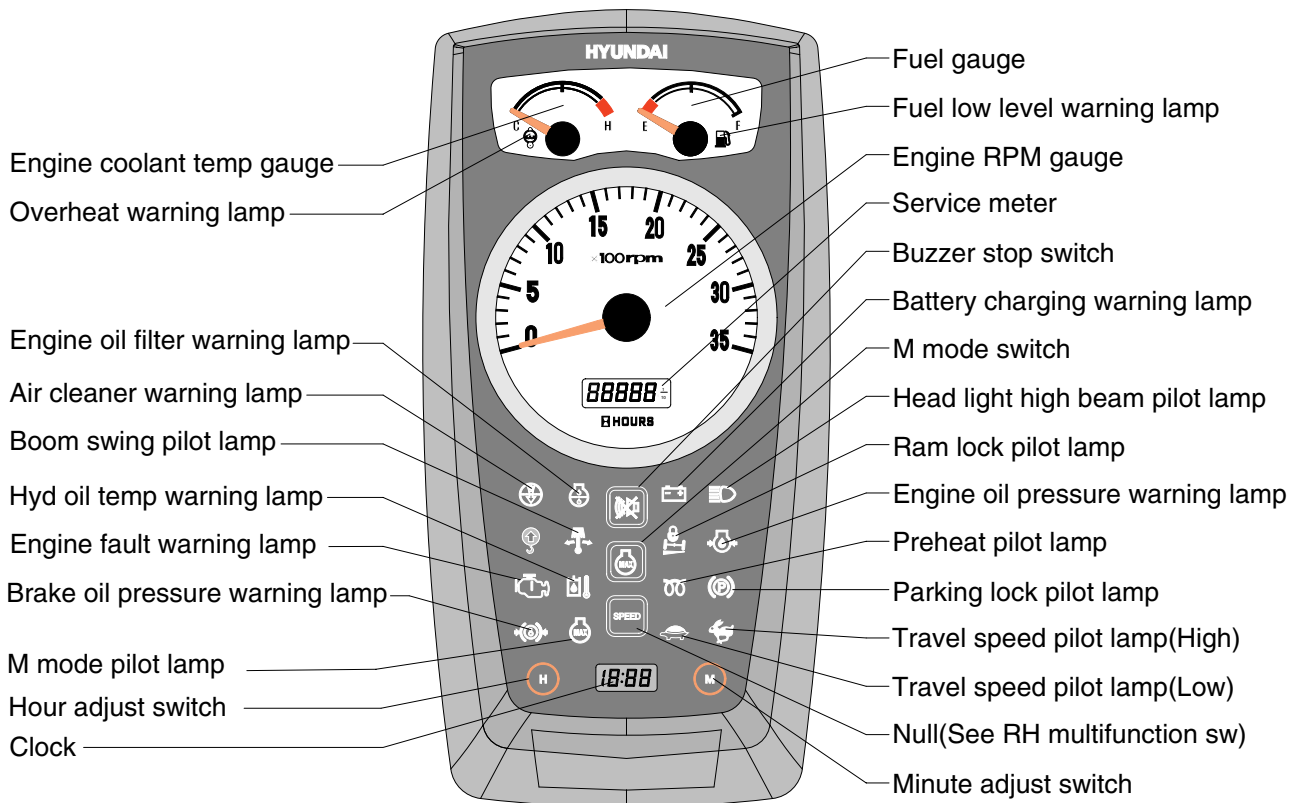

55W7A3CD02

## 2) CLUSTER CHECK PROCEDURE

### (1) Start key : ON

- ① Check monitor initial 6 seconds
  - a. All lamps light up.
  - b. Buzzer sound.
- ② Check monitor after 3 seconds : Indicate machine condition
  - a. Tachometer : 0 rpm
  - b. Fuel gauge : Pointed at appropriate level
  - c. Engine coolant temperature gauge : Pointed at appropriate level
  - d. Warning lamp
    - ※ During start key **ON** the engine oil pressure lamp and battery charging lamp go ON, but it is not abnormal.
    - ※ When engine coolant temperature below 30°C, the warming up lamp lights up and then operating the preheat switch.

### (2) Start of engine

- ① Check machine condition
  - a. Tachometer pointed at present rpm
  - b. Gauge and warning lamp : Indicate at present condition.
    - ※ When normal condition : All warning lamp OFF
  - c. Travel speed pilot lamp : Low(Turtle)
- ② When abnormal condition
  - a. The lamp lights up and the buzzer sounds.
  - b. If **BUZZER STOP** switch is pressed, buzzer sound is canceled but the lamp lights up until normal condition.

### 3. CLUSTER CONNECTOR

#### 1) CN-56 CONNECTOR

No.	Signal	Input/Output
1	Power IG 12V	-
2	Power 12V	-
3	Fuel level sender	Input
4	Water temp sender	Input
5	Tacho signal	Input
6	GND	-
7	GND	-
8	GND(sensor)	-
9	Travel relay	-
10	Pre-heat signal	Output
11	M mode	Output
12	Crawler / wheel	-

#### 2) CN-57 CONNECTOR

No.	Signal	Input/Output
1	Air cleaner switch	Input
2	Hyd oil temp sensor	Input
3	Engine oil pressure switch	Input
4	Alt level	Input
5	High beam signal	Input
6	Engine fault	Input
7	Engine oil filter	Input
8	Overload switch	Input
9	Brake fail pressure switch	Input
10	Boom swing signal	Input
11	Travel signal	Input
12	Parking signal	Input
13	Ramlock signal	Input
14	Illumination	Input
15	Neutral signal	-
16	Over heat signal	-

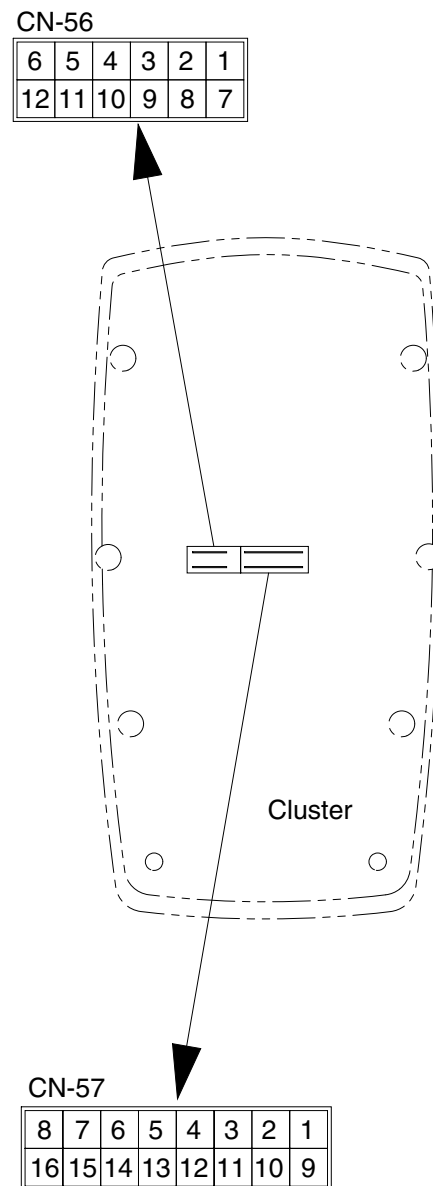

R5574EL40

## 4. CLUSTER FUNCTION

### 1) GAUGES AND DISPLAYS

#### (1) Service meter



- ① This meter shows the total operation hours of the machine.
- ② Always ensure the operating condition of the meter during the machine operation.  
Inspect and service the machine based on hours as indicated in chapter 6, **maintenance**.

#### (2) Fuel gauge

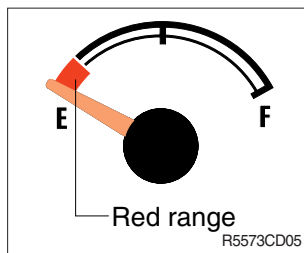

- ① This gauge indicates the amount of fuel in the fuel tank.
- ② Fill the fuel when the indicator is in the red range or warning lamp ON.  
\* If the gauge indicates the red range or warning lamp ON, even though the machine is on the normal condition, check the electric device as that can be caused by the poor connection of electricity or sensor.

#### (3) Engine coolant temperature gauge

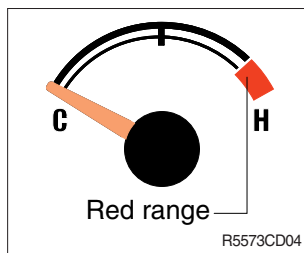

- ① This indicates the temperature of coolant.  
· Red range : Above 105°C(221°F)
- ② When the red range pointed or warning lamp ON, engine do not abruptly stop but run it at medium speed to allow it to cool gradually, then stop it.  
Check the radiator and engine.  
\* If the engine is stopped without cooled down running, the temperature of engine parts will rise suddenly, this could cause severe engine trouble.

#### (4) Engine rpm gauge

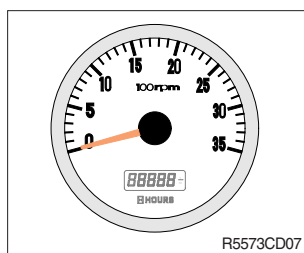

- ① This gauge displays the number of engine revolutions per minute.

#### (5) Clock



- ① This displays the current time.
- ② Refer to the hour/minute adjust switch for adjusting time.

## 2) WARNING AND PILOT LAMPS

### (1) Fuel low level warning lamp



- ① This lamp blinks and the buzzer sounds when the level of fuel is below 13 l (3.4U.S. gal).
- ② Fill the fuel immediately when the lamp blinks.

### (2) Hydraulic oil temperature warning lamp

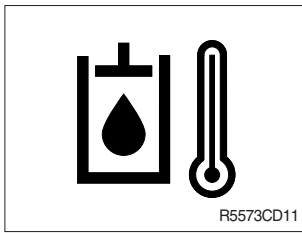

- ① This warning lamp operates and the buzzer sounds when the temperature of hydraulic oil is over 105 °C ( 221 °F) .
- ② Check the hydraulic oil level when the lamp blinks.
- ③ Check for debris between oil cooler and radiator.

### (3) Overheat warning lamp

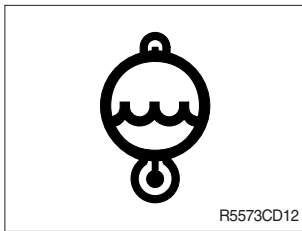

- ① This lamp blinks and the buzzer sounds when the temperature of coolant is over the normal temperature 110°C ( 230°F) .
- ② Check the cooling system when the lamp blinks.

### (4) Engine oil pressure warning lamp

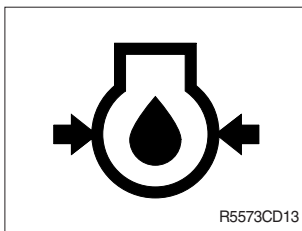

- ① This lamp blinks and the buzzer sounds after starting the engine because of the low oil pressure.
- ② If the lamp blinks during engine operation, shut OFF engine immediately. Check oil level.

### (5) Air cleaner warning lamp

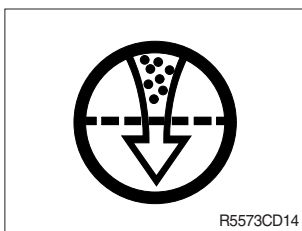

- ① This lamp blinks and the buzzer sounds when the filter of air cleaner is clogged.
- ② Check the filter and clean or replace it.

**(6) Battery charging warning lamp**

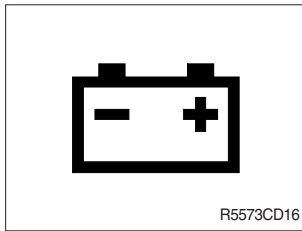

- ① This lamp blinks and the buzzer sounds when the starting switch is ON, it is turned OFF after starting the engine.
- ② Check the battery charging circuit when this lamp blinks during engine operation.

**(7) Engine fault warning lamp**

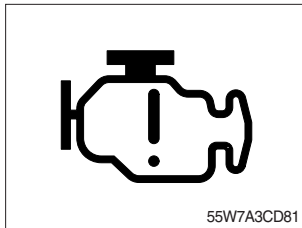

- ① This lamp is ON and the buzzer sounds when the ECM on the engine is abnormal.
- ② Check the ECM of engine.  
※ Check the fault code by the Yanmar Engine Diagnostic Service Tool(YEDST).  
Refer to our web(CERES) for ECM(Electronic control manual) of TNV Engine.

**(8) Preheat pilot lamp**

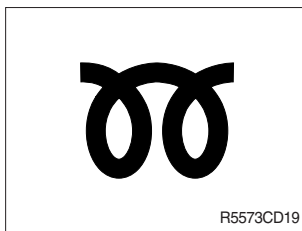

- ① When engine preheating switch is turned ON, pilot lamp comes ON.
- ② Refer to the preheating switch for details.

**(9) Travel speed pilot lamp(High)**

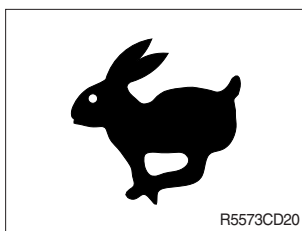

- ① When this lamp turned ON, the machine travel high speed.
- ② Refer to the travel speed select switch for details.

**(10) Travel speed pilot lamp(Low)**

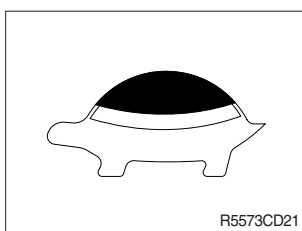

- ① When this lamp turned ON, the machine travel low speed.
- ② Refer to the travel speed select switch for details.

**(11) Brake oil pressure warning lamp**

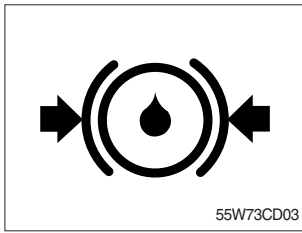

- ① The lamp lights ON when the oil pressure of service brake drops below the normal range.
- ② When the lamp is ON, stop the engine and check for its cause.
- ※ **Do not operate until any problems are corrected.**

**(12) Parking lock pilot lamp**

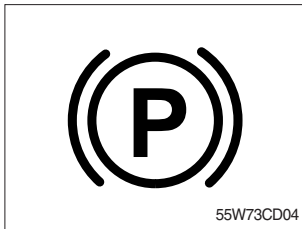

- ① When the parking brake is actuated, the lamp lights ON.
- ※ **Check the lamp is OFF before driving.**

**(13) Ram lock pilot lamp**

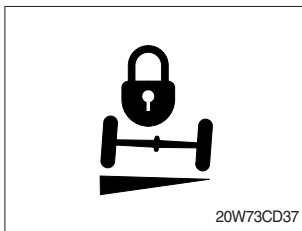

- ① This pilot lamp lights ON when ram lock switch is rear position.
- ② Also, the pilot lamp lights ON when the parking switch is ON or service brake is applied.

**(14) Head light high beam pilot lamp**

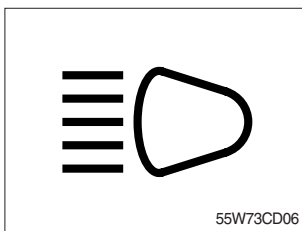

- ① This lamp is ON when the head light switch is high beam position or passing function.
- ② When passing other machines ahead, this lamp must be used for a few seconds to give other machines warning for a few seconds.

**(15) M mode pilot lamp**



- ① This lamp is ON when the M mode switch is pressed.

### 3) SWITCHES

#### (1) Buzzer stop switch

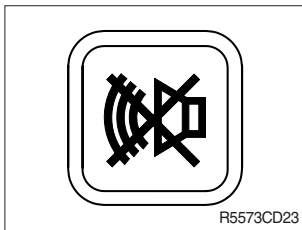

- ① When the starting switch is turned ON first, normally the alarm buzzer sounds for 6 seconds during lamp check operation.
- ② The red lamp lights ON and the buzzer sounds when the machine has a problem.  
In this case, press this switch and buzzer stops, but the red lamp lights until the problem is cleared.

#### (2) M mode switch

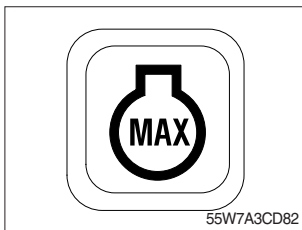

- ① This switch is used to maximum power.
- ② When this switch is pressed, the M mode pilot lamp is ON.

#### (3) Hour adjust switch

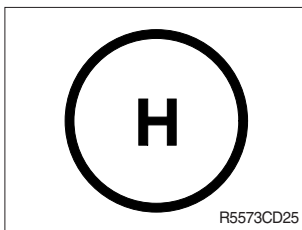

- ① This switch is used to adjust hour.
- ② The switch is pressed, hour is increased.

#### (4) Minute adjust switch

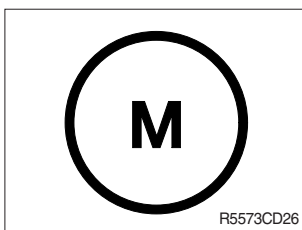

- ① This switch is used to adjust minute.
- ② The switch is pressed, minute is increased.

## 1. POWER CIRCUIT

The negative terminal of battery is grounded to the machine chassis through master switch.

When the start switch is in the OFF position, the current flows from the positive battery terminal as shown below.

### 1) OPERATING FLOW

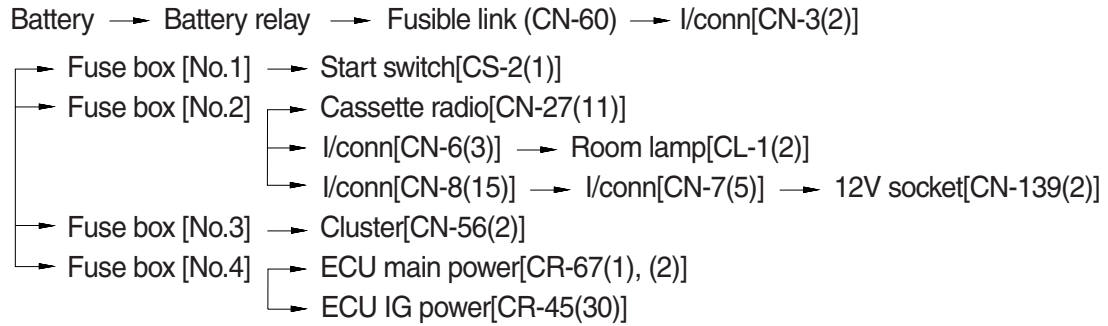

※ I/conn : Intermediate connector

### 2) CHECK POINT

Engine	Start switch	Check point	Voltage
OFF	OFF	① - GND (Battery) ② - GND (Battery relay) ③ - GND (Fusible link)	10~12.5V

※ GND : Ground

# POWER CIRCUIT

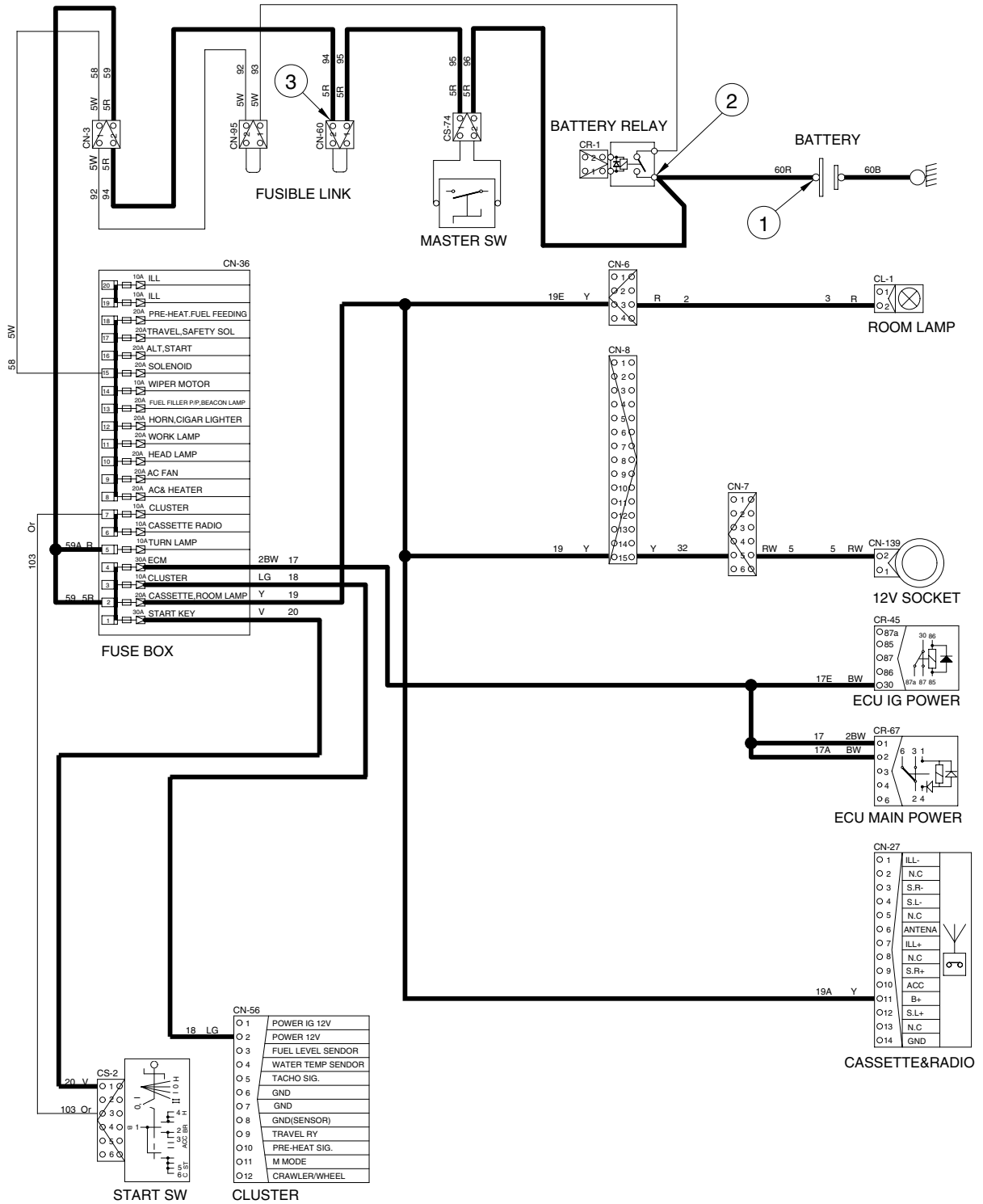

## 2. STARTING CIRCUIT

### 1) OPERATING FLOW

Battery(+) terminal → Battery relay[CR-1] → Fusible link[CN-60]  
 → I/conn[CN-3(2)] → Fuse box No.1 → Start key[CS-2(1)]

※ Start switch : ON

→ Start switch ON [CS-2(2)] → I/conn [CN-2(1)] →  
 Battery relay [CR-1]:Battery relay operating(All power is supplied with the electric component)  
 → Start switch ON [CS-2(3)] → Fuse box (All power is supplied with electric component)

※ Start switch : START

Start switch START [CS-2(5)] → I/conn [CN-1(1)] → ECM [CN-93(8)]  
 → Neutral relay[CR-38(86)→(87)] → Anti-restart relay[CR-5(86)→(87)]  
 → I/conn [CN-2(5)] → Start relay [CR-23(C2)→(2)]  
 → Start motor operating

### 2) CHECK POINT

Engine	Start switch	Check point	Voltage
Operating	Start	① - GND (Battery) ② - GND (Start key) ③ - GND (Battery relay M4) ④ - GND (Starter B <sup>+</sup> ) ⑤ - GND (Starter M) ⑥ - GND (Start relay) ⑦ - GND (Battery relay M8)	10 ~ 12.5V

※ GND : Ground

# STARTING CIRCUIT

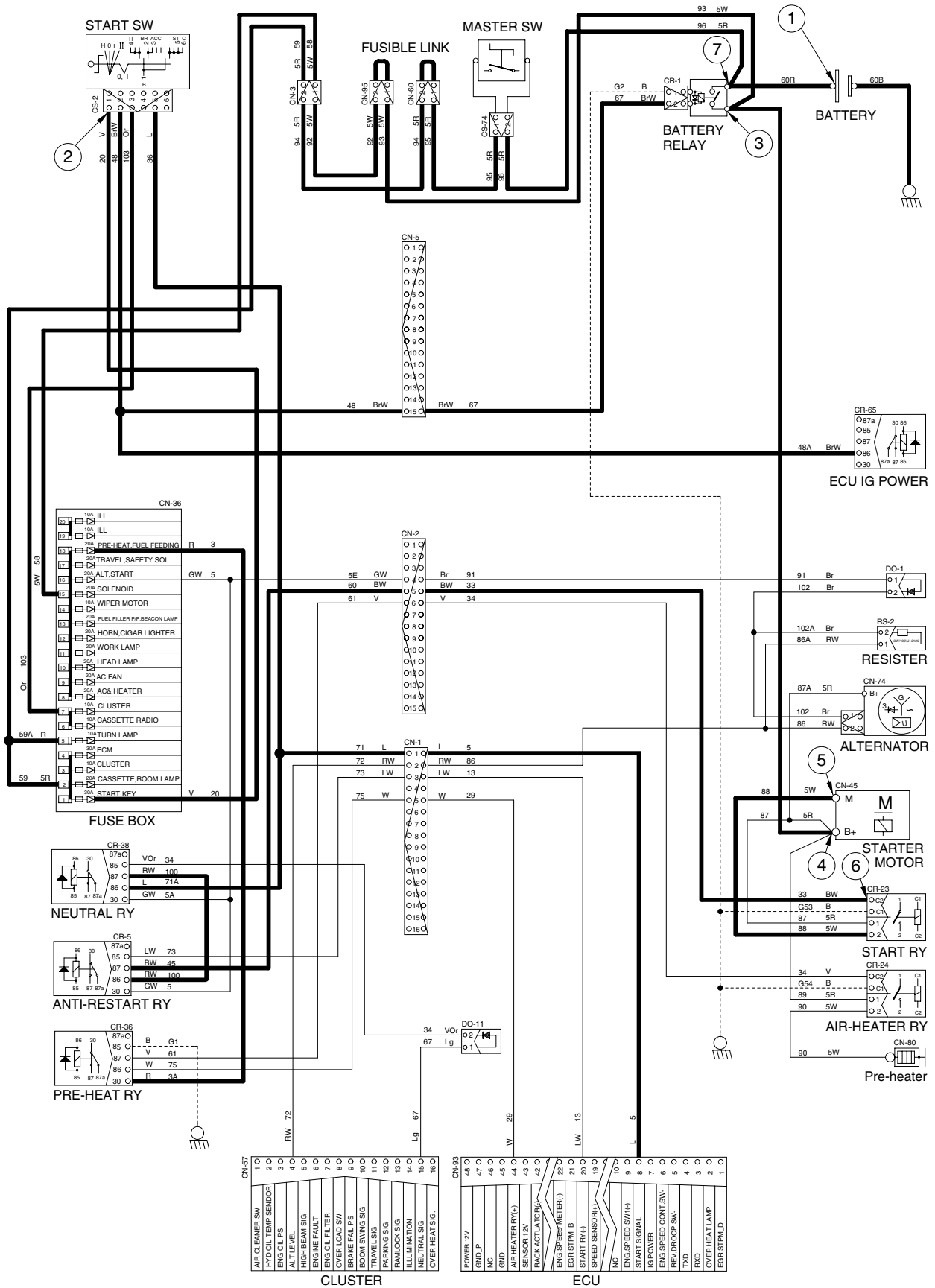

### 3. CHARGING CIRCUIT

When the starter is activated and the engine is started, the operator releases the key switch to the ON position.

Charging current generated by operating alternator flows into the battery through the Battery relay(CR-1).

The current also flows from alternator to each electrical component and controller through the fuse box.

#### 1) OPERATING FLOW

##### (1) Warning flow

Alternator "L" terminal → I/conn [CN-1(2)] → Cluster [CN-57(4)] → Cluster warning lamp

##### (2) Charging flow

Alternator "B+" terminal → Battery(+) terminal

#### 2) CHECK POINT

Engine	Start switch	Check point	Voltage
ON	ON	① - GND (Battery voltage) ② - GND (Battery relay) ③ - GND (Alternator B+ terminal) ④ - GND (Alternator L terminal) ⑤ - GND (Cluster)	10~12.5V

※ GND : Ground

# CHARGING CIRCUIT

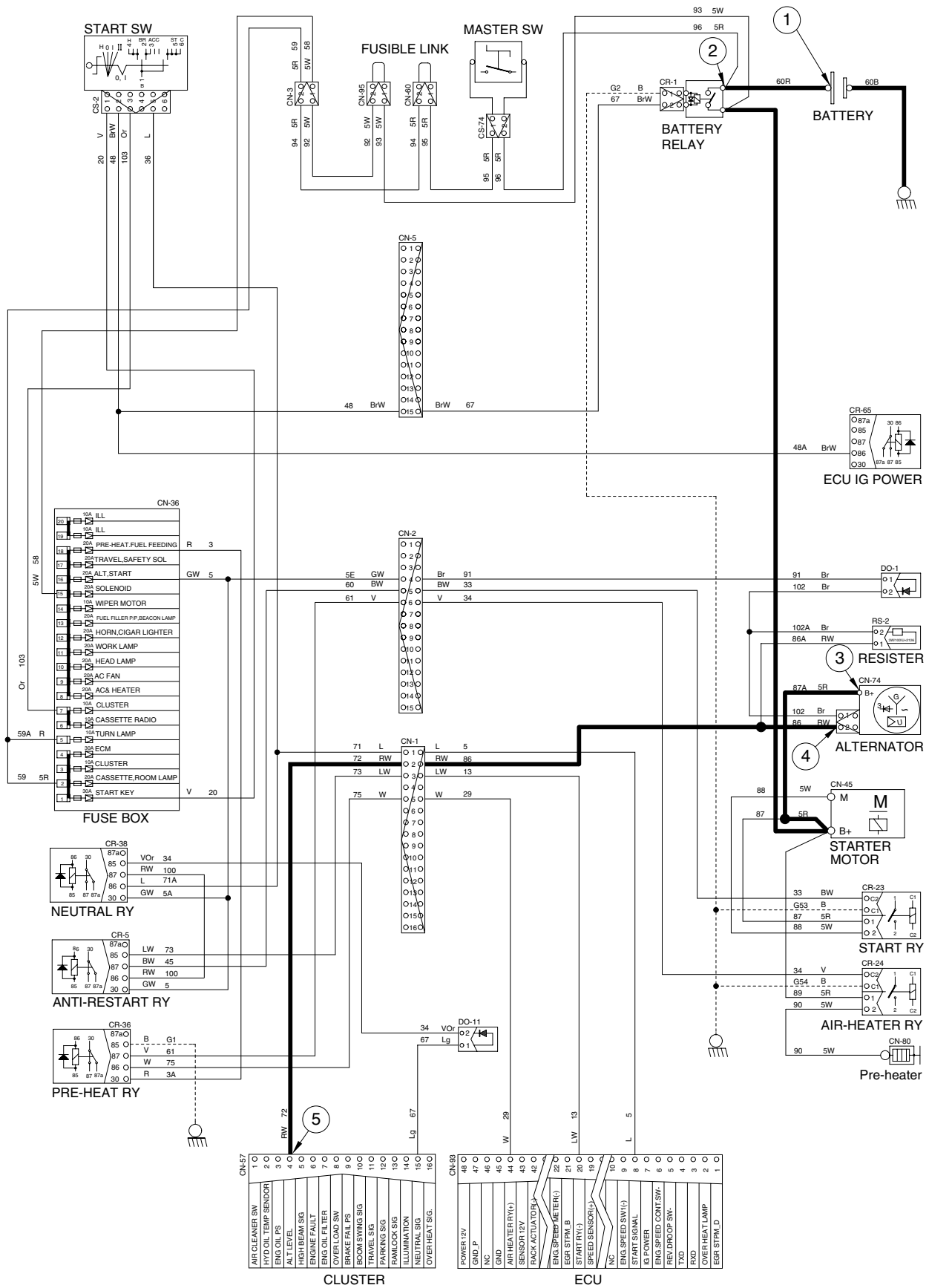

55W7A4EL06

## 4. HEAD AND WORK LIGHT CIRCUIT

### 1) OPERATING FLOW

Fuse box (No.10) → Head lamp switch[CS-21(4)]

Fuse box (No.11) → Work lamp switch[CS-36(6)]

#### (1) Main light switch ON : 1st step

Head light switch ON [CS-21(2)] → I/conn[CN-8(11)] → I/conn[CN-97(11)]

→ Multifunction sw left lever(4)→(5) → I/conn[CN-97(10)] → I/conn[CN-8(3)]

→ Head light low relay[CR-13(86),(87)] → I/conn[CN-8(2)] → Head light ON[CL-3(1), CL-4(1)]  
: Head light ON

#### (2) Main light switch ON : 2nd step

Head light switch[CS-21(4)] → I/conn[CN-8(4)] → I/conn[CN-97(8)]

→ Multifunction sw left lever(12)→(3) → I/conn[CN-97(9)] → I/conn[CN-8(1)]

→ Head light high relay[CR-14(86),(87)] → I/conn[CN-8(8)]

→ Head light ON[CL-3(2), CL-4(2)] : Head light high beam ON

#### (3) Work lamp switch ON :

Work lamp switch ON[CS-36(2)] → Work lamp relay[CR-3(86)→(87)] → I/conn[CN-8(14)]

→ I/conn[CN-12(2)] → Work lamp ON [CL-5(2)] : Work lamp ON

### 2) CHECK POINT

Engine	Start switch	Check point	Voltage
STOP	ON	① - GND(Fuse box) ② - GND(Switch power input) ③ - GND(Switch power output) ④ - GND(Head light)	10~12.5V
STOP	ON	⑤ - GND(Fuse box) ⑥ - GND(Switch power input) ⑦ - GND(Switch power output) ⑧ - GND(Work light)	10~12.5V

※ GND : Ground

# HEAD AND WORK LAMP CIRCUIT

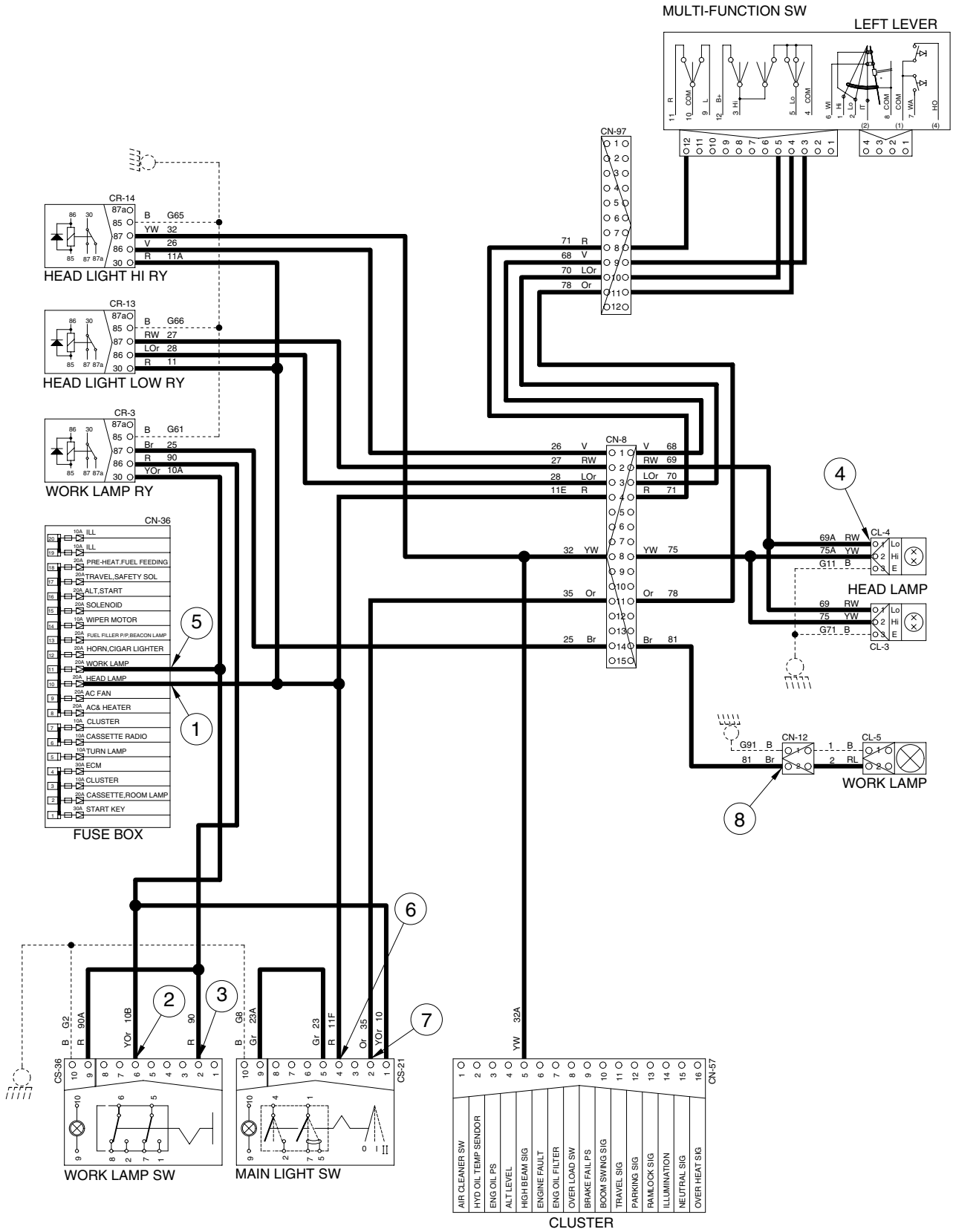

## 5. BEACON LAMP CIRCUIT

### 1) OPERATING FLOW

Fuse box (No.13) → Beacon lamp switch[CS-23(5)]

#### (1) Beacon lamp switch ON

Beacon lamp switch ON [CS-23(1)] → Switch Indicator lamp ON [CS-23(9)]  
Beacon lamp switch ON [CS-23(1)] → I/conn[CN-6(1)] → Beacon lamp ON [CL-7]

### 2) CHECK POINT

Engine	Start switch	Check point	Voltage
STOP	ON	① - GND(Fuse box) ② - GND(Switch power input) ③ - GND(Switch power output) ④ - GND(Beacon lamp)	10~12.5V

※ GND : Ground

# BEACON LAMP CIRCUIT

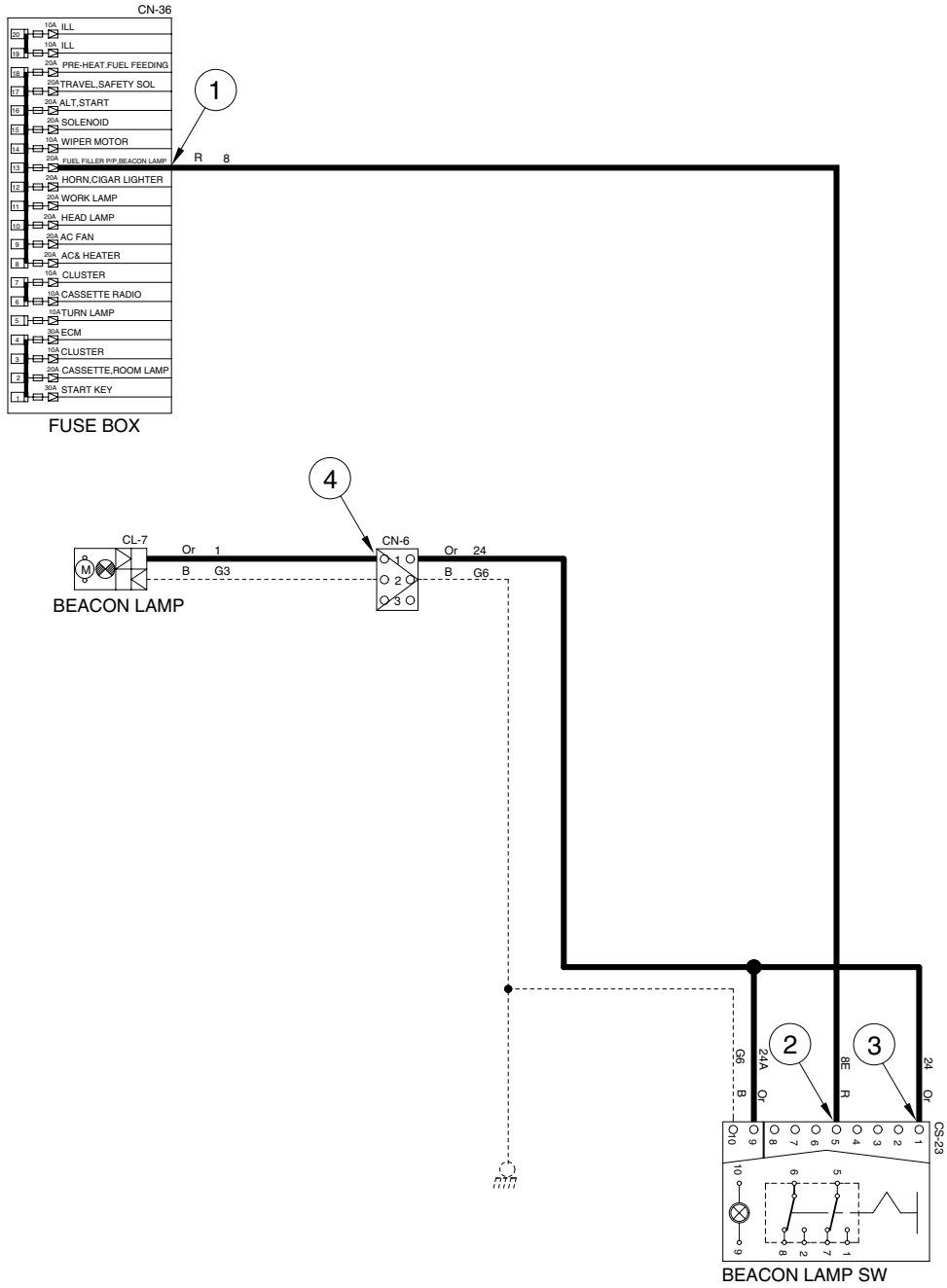

55W7A4EL08

## 6. WIPER AND WASHER CIRCUIT

### 1) OPERATING FLOW

#### (1) Key switch ON

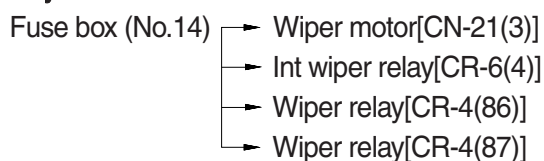

#### (2) Wipe switch ON : 1st step(Intermittent)

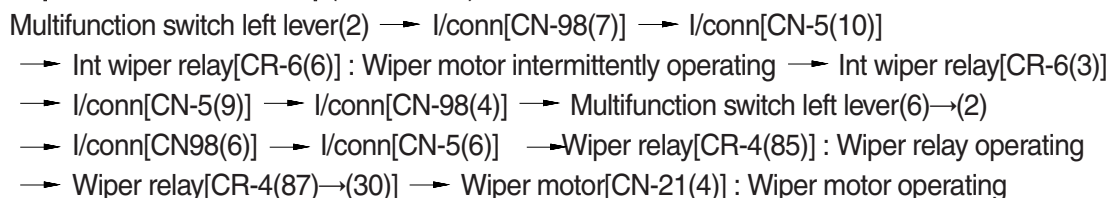

#### (3) Wiper switch ON : 2nd or 3rd step

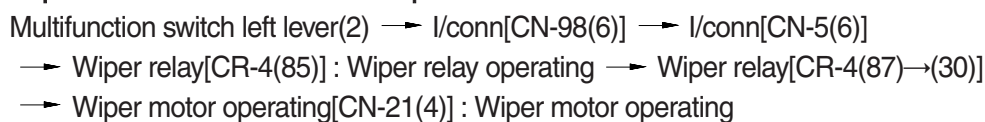

#### (4) Auto parking(When switch OFF)

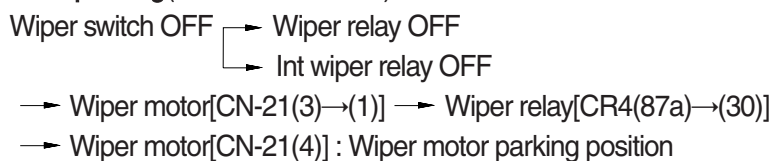

#### (5) Washer switch ON

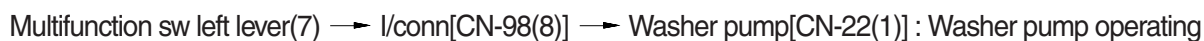

### 2) CHECK POINT

Engine	Start switch	Check point	Voltage
STOP	ON	① - GND(Fuse box) ② - GND(Wiper motor)	10~12.5V

※ GND : Ground

# WIPER AND WASHER CIRCUIT

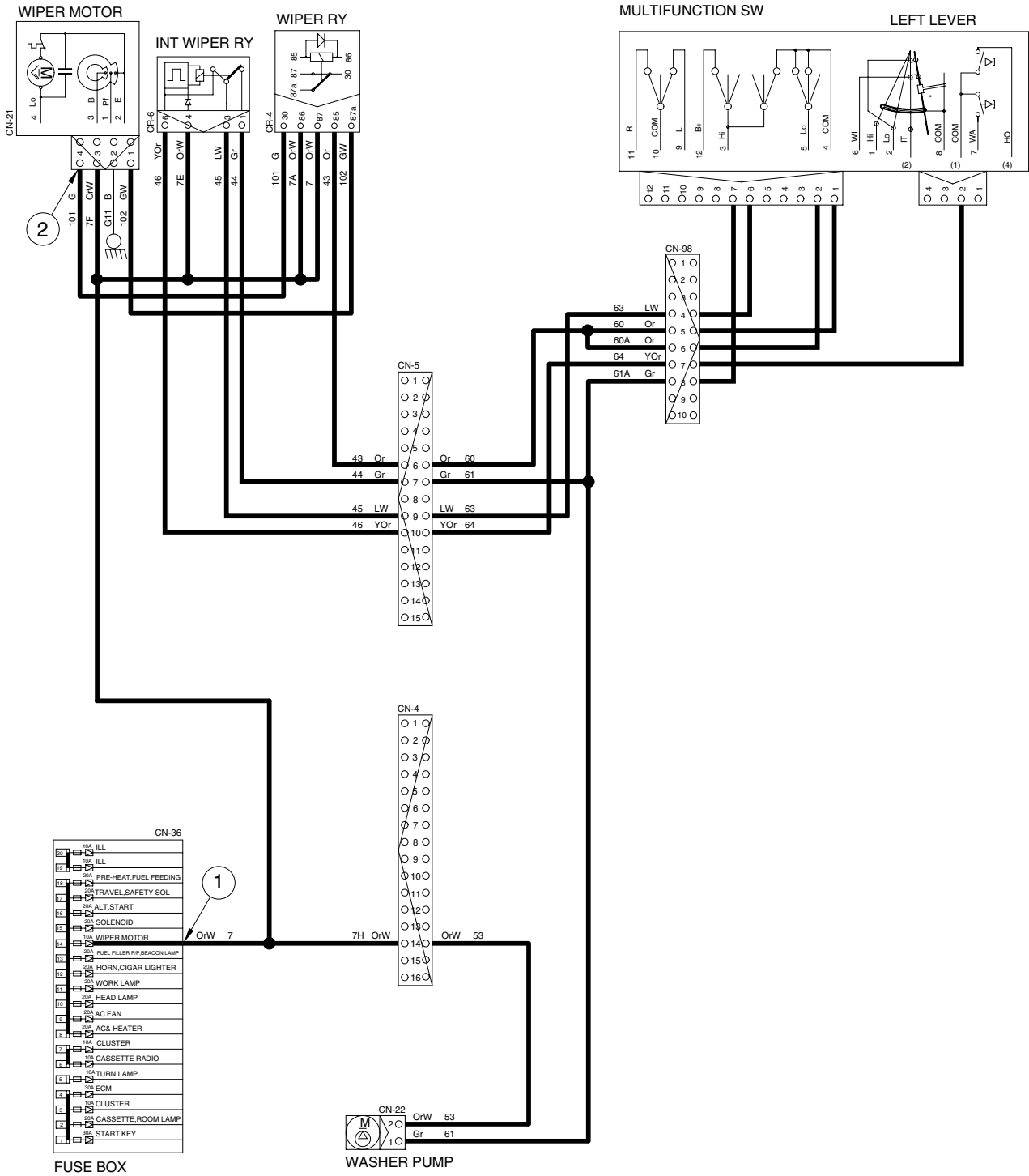

55W7A4EL09



# ILLUMINATION CIRCUIT

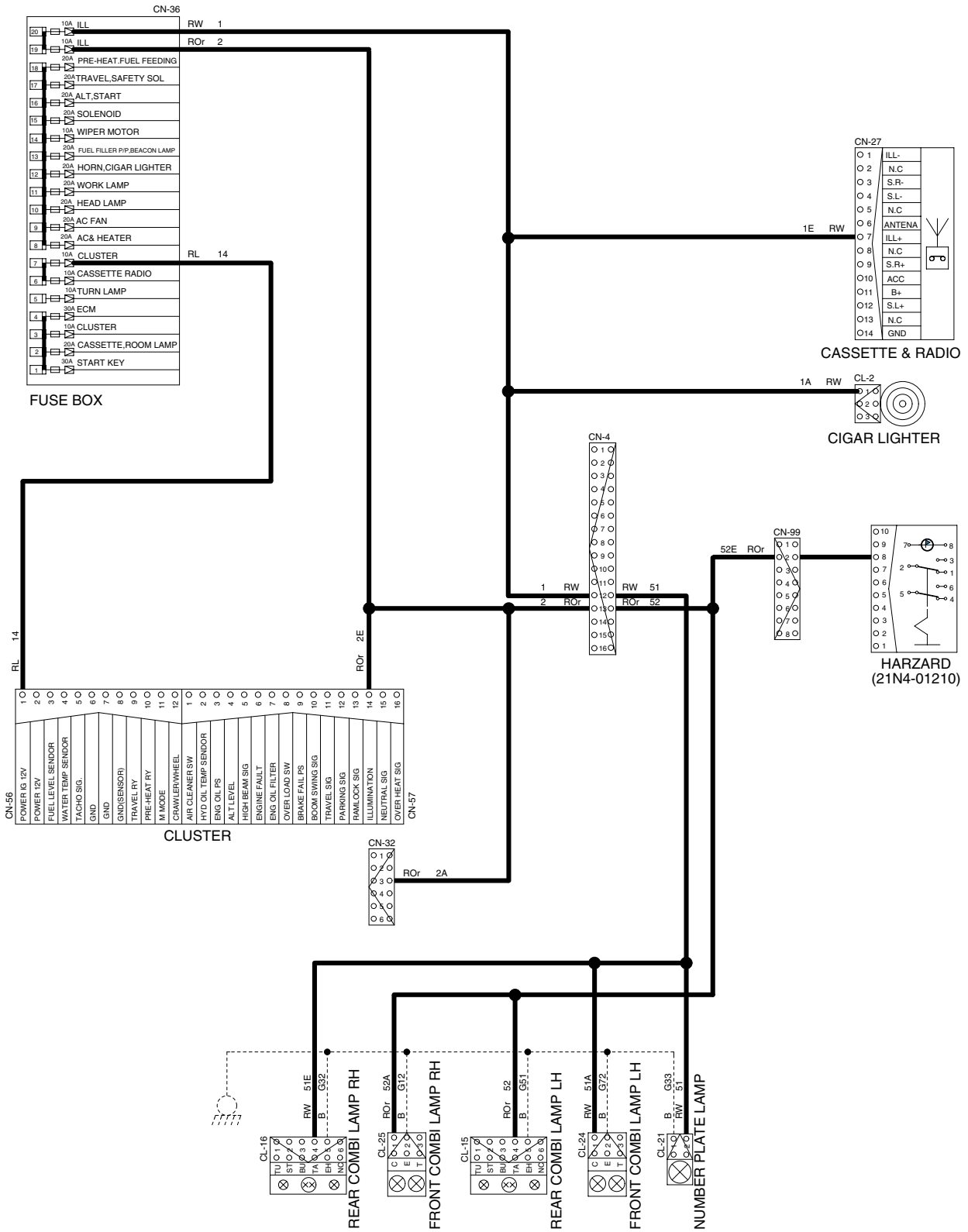

# COMBINATION LAMP CIRCUIT

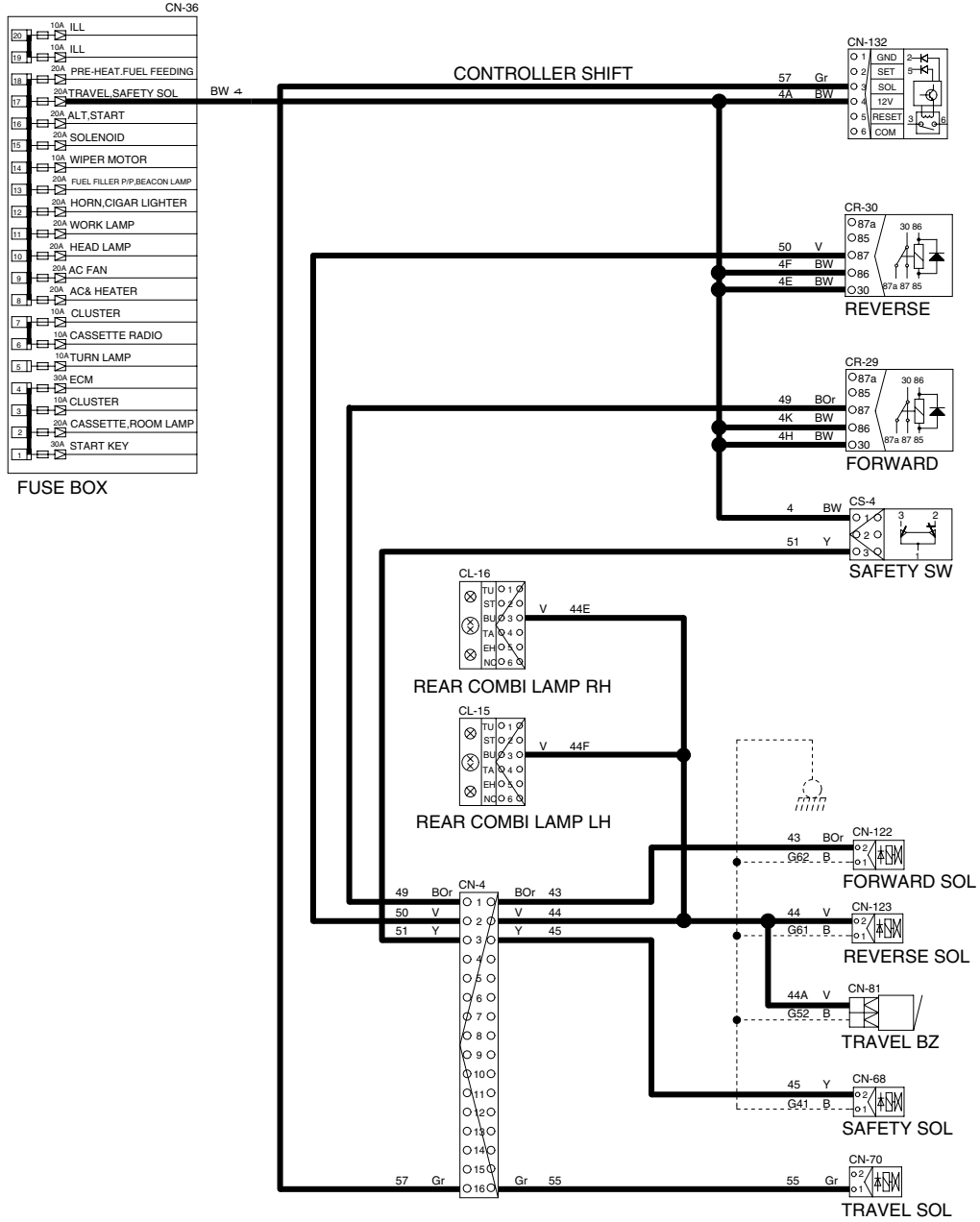

55W7A4EL12

# ELECTRIC CIRCUIT FOR HYDRAULIC

