

GROUP 3 PILOT CIRCUIT

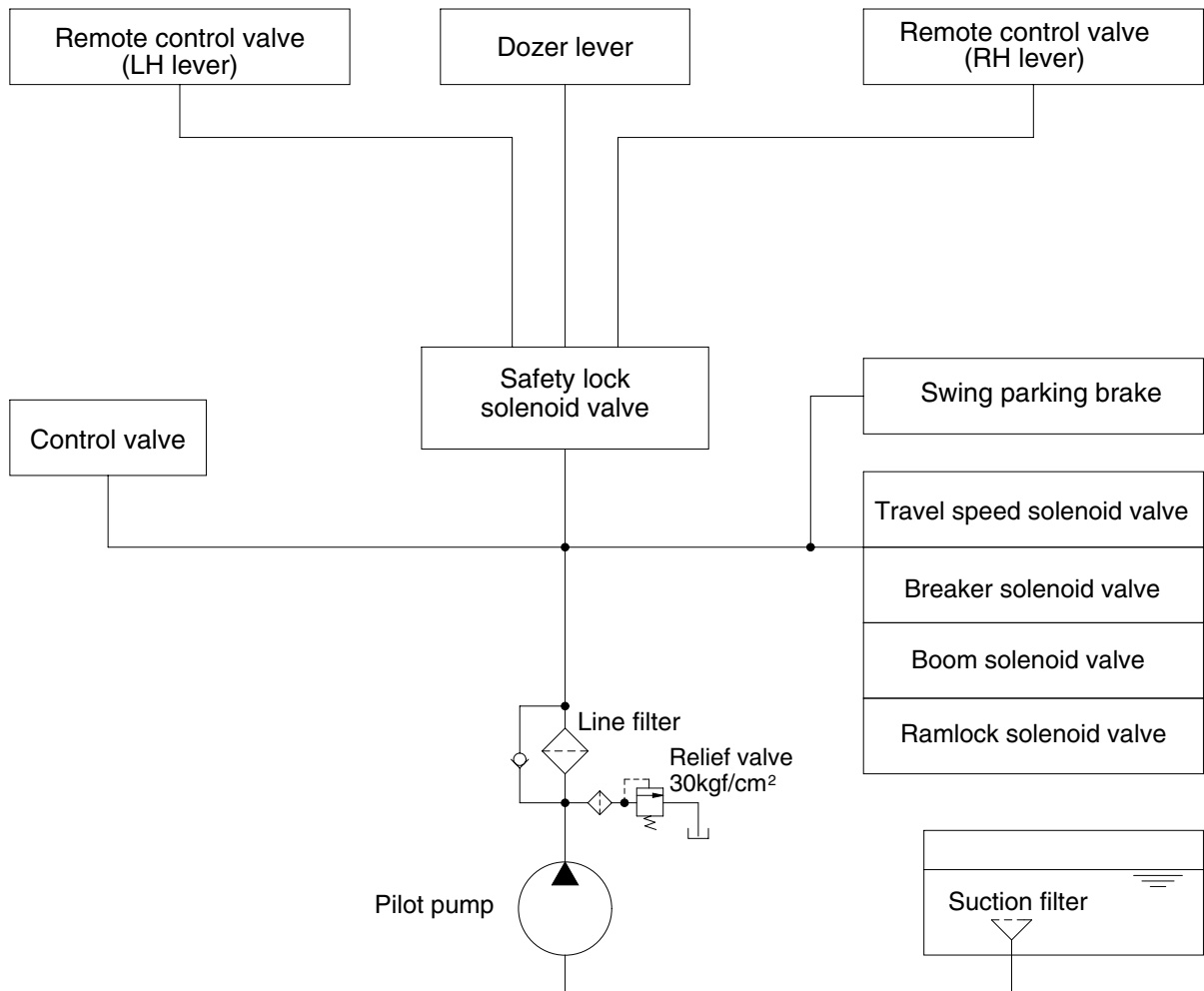

55W73CI03

The pilot circuit consists of suction circuit, delivery circuit and return circuit.

The pilot pump is provided with relief valve, receives the oil from the hydraulic tank through the suction filter.

The discharged oil from the pilot pump flows to the remote control valve through line filter, solenoid valve assemblies, swing parking brake, main control valve and safety lock solenoid valve.

1. SUCTION, DELIVERY AND RETURN CIRCUIT

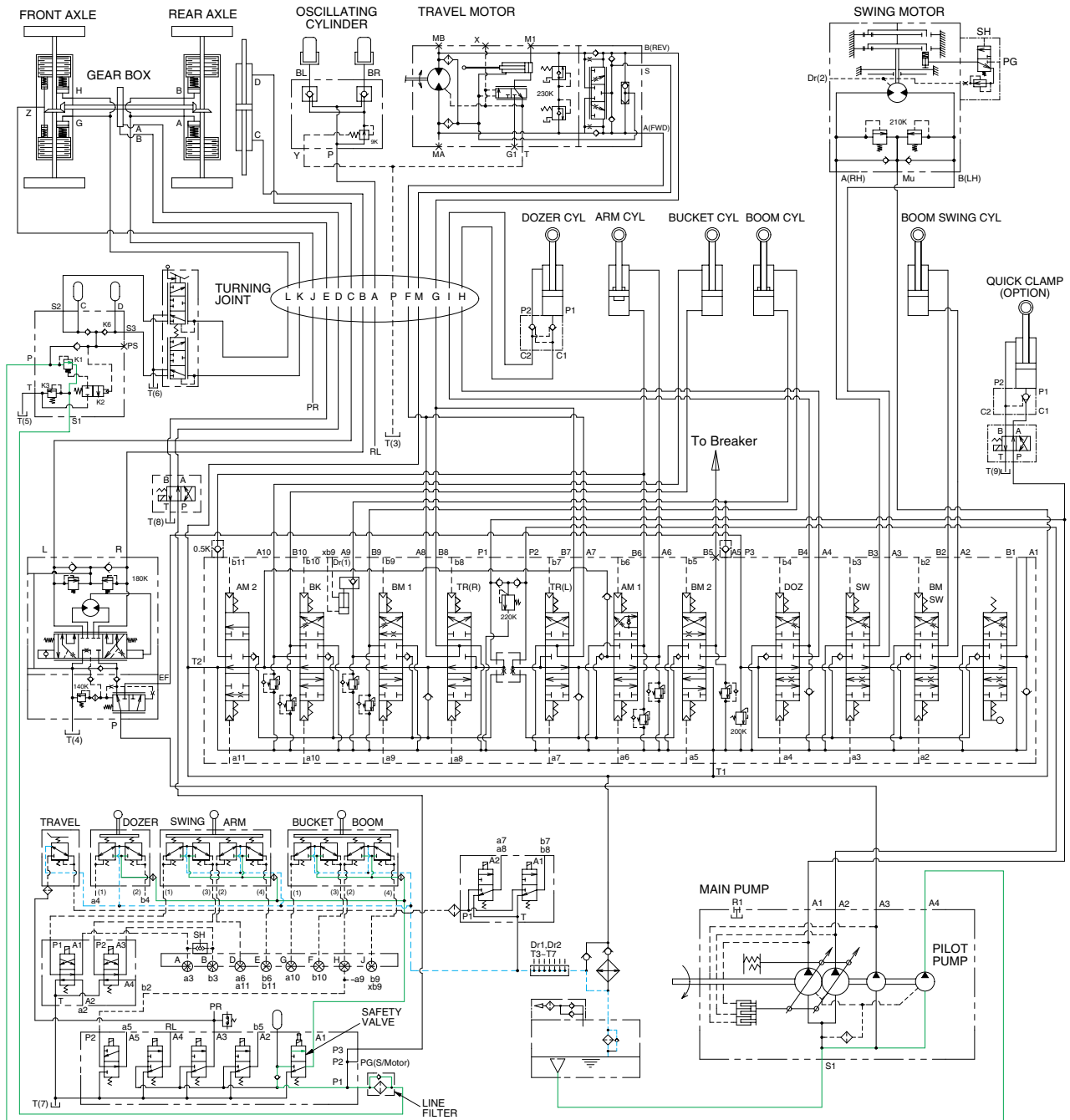

55W73HC02

The pilot pump receives oil from the hydraulic tank. The discharged oil from the pilot pump flows to the safety solenoid valve through the line filter. The oil is filtered by the line filter. The oil filtered by line filter flows remote control valve through safety solenoid valve. The return oil flow into the hydraulic tank.

2. SAFETY VALVE(SAFETY LEVER)

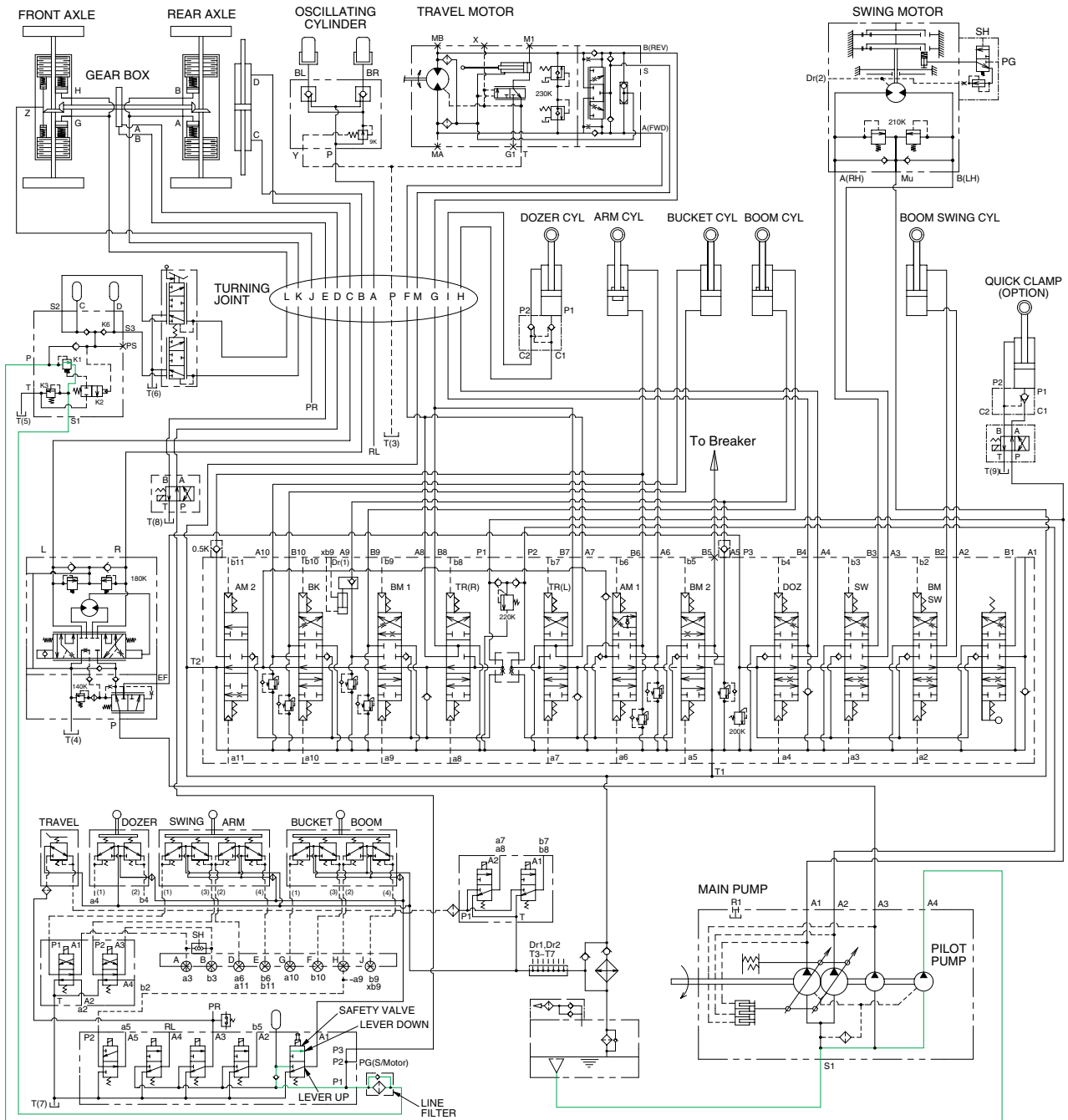

55W73HC03

When the lever of the safety solenoid valve is moved downward, oil flows into the remote control valve through solenoid valve and line filter.

When the lever of the safety solenoid valve is moved upward, oil does not flow into the remote control valve, because of the blocked port.

3. TRAVEL SPEED CONTROL SYSTEM

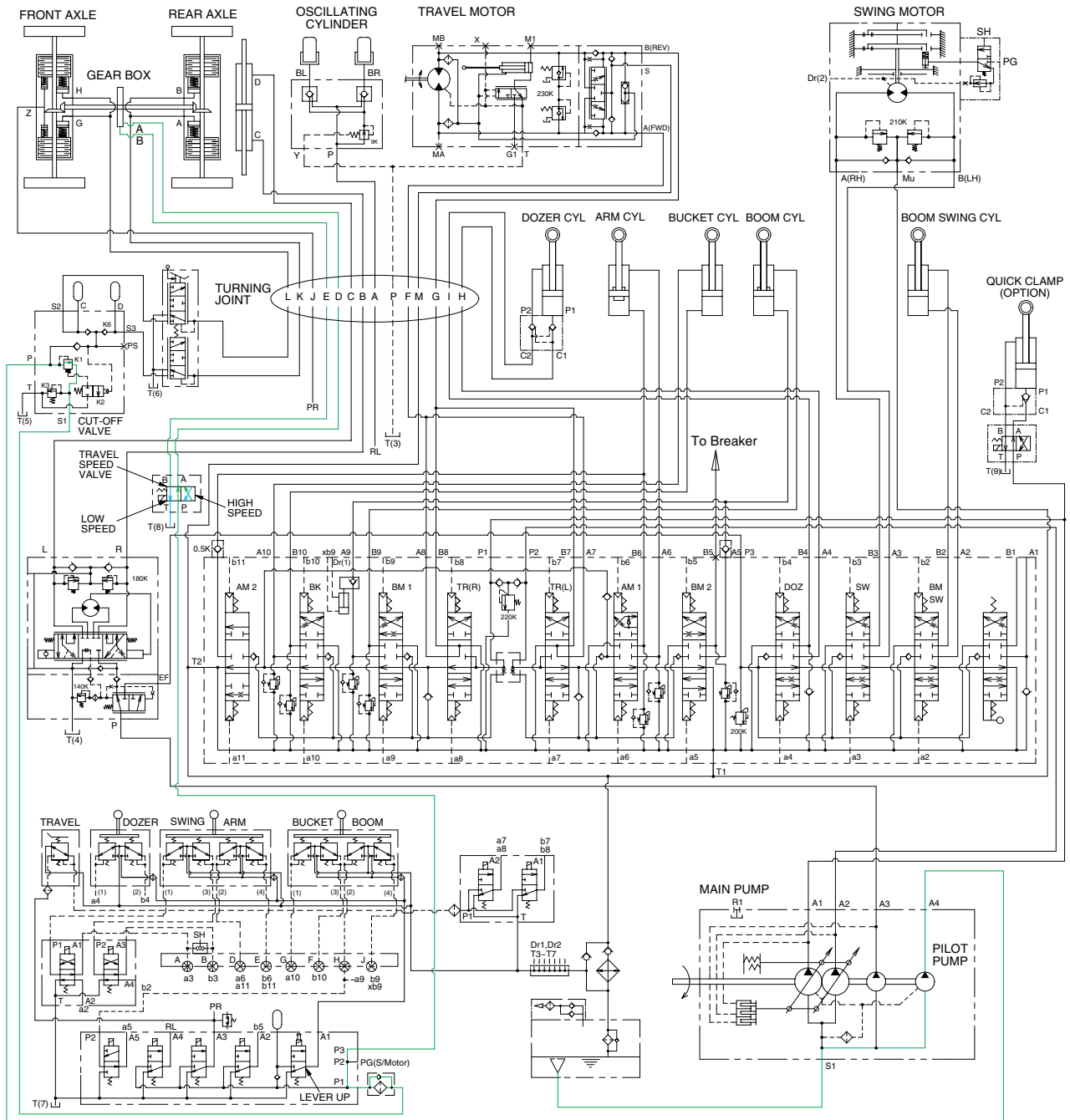

55W7HC04

When RH multifunction switch was placed in high or low position, the pressure oil from pilot pump flows through relief valve of cut off valve to travel speed solenoid valve, thus the gear box is changed into high or low speed condition.

4. SWING PARKING BRAKE RELEASE

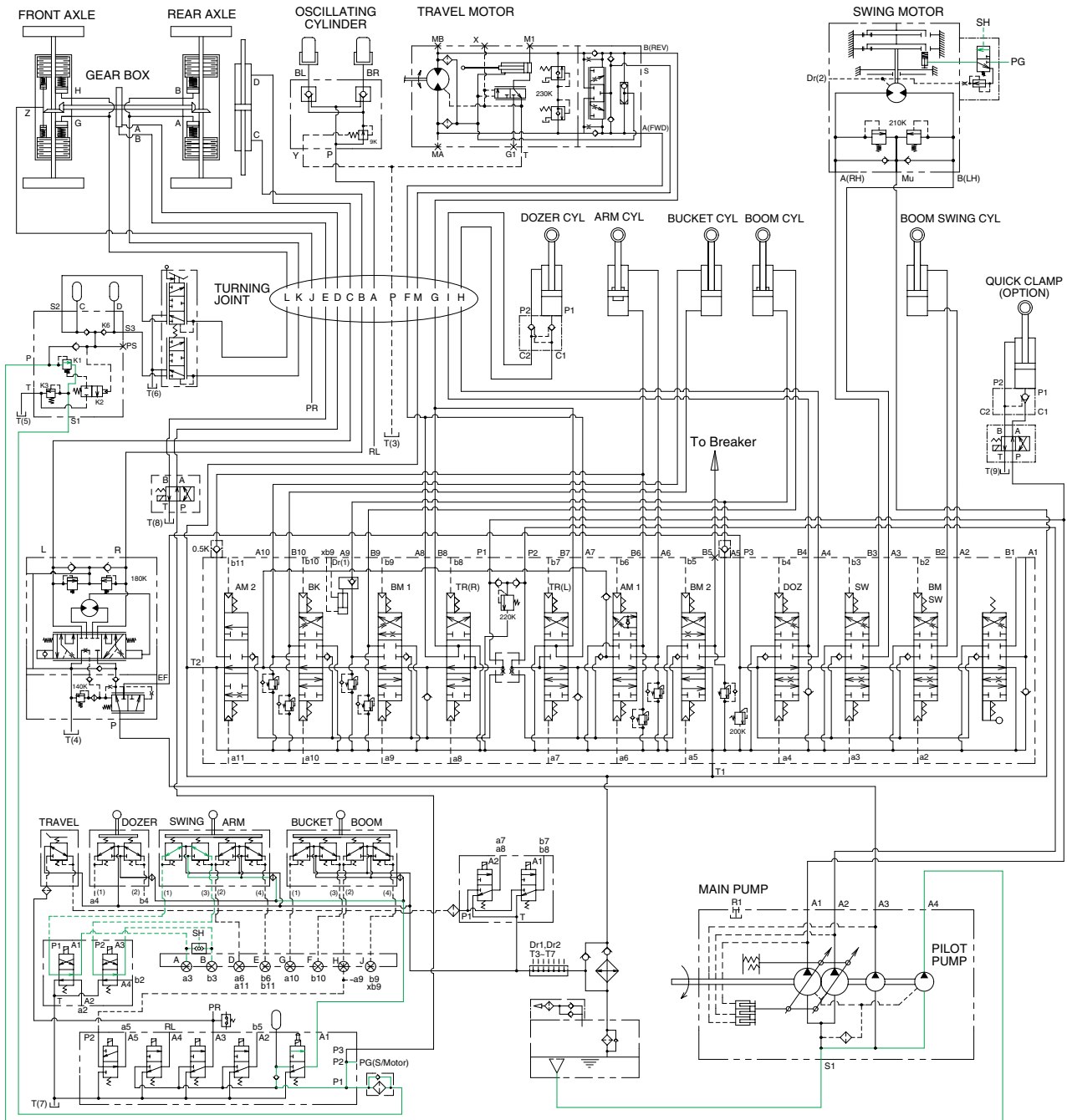

55W7HC05

When the swing control lever is tilted, the pilot oil flow into SH port of shuttle valve, this pressure move spool so, discharged oil from pilot valve flow into PG port.

This pressure is applied to swing motor disc, thus the brake is released.

When the swing control lever is set in the neutral position, oil in the swing motor disc cylinder is drained, thus the brake is applied.