

GROUP 7 GEAR BOX

1. REMOVAL AND INSTALL

1) REMOVAL

- (1) Swing the work equipment 90° and lower it completely to the ground.
- (2) Operate the control levers and pedals several times to release the remaining pressure in the hydraulic piping.
- (3) Loosen the breather slowly to release the pressure inside the hydraulic tank.

▲ Escaping fluid under pressure can penetrate the skin causing serious injury.

※ When pipes and hoses are disconnected, the oil inside the piping will flow out, so catch it in oil pan.

- (4) Remove the propeller shaft mounting nuts(3).

· Tightening torque : $7.4 \pm 1.5 \text{kgf} \cdot \text{m}$
($53.5 \pm 10.8 \text{lbf} \cdot \text{ft}$)

- (5) Remove the travel motor mounting bolts(2).

· Tightening torque : $14.7 \pm 2.2 \text{kgf} \cdot \text{m}$
($106 \pm 15.9 \text{lbf} \cdot \text{ft}$)

- (6) Remove the hoses(4).

※ **Fit blind plugs to the disconnected hoses.**

- (7) Remove the mounting bolts(2), then remove the gear box(1) device assembly.

· Weight : 63kg(140lb)
· Tightening torque : $19.6 \pm 2.9 \text{kgf} \cdot \text{m}$
($142 \pm 21 \text{lbf} \cdot \text{ft}$)

2) INSTALL

- (1) Carry out installation in the reverse order to removal.
- (2) Bleed the air from the gear box.
 - ① Remove the air vent plug.
 - ② Pour in hydraulic oil until it overflows from the port.
 - ③ Tighten plug lightly.
 - ④ Start the engine, run at low idling, and check oil come out from plug.
 - ⑤ Tighten plug fully.
- (3) Confirm the hydraulic oil level and check the hydraulic oil leak or not.

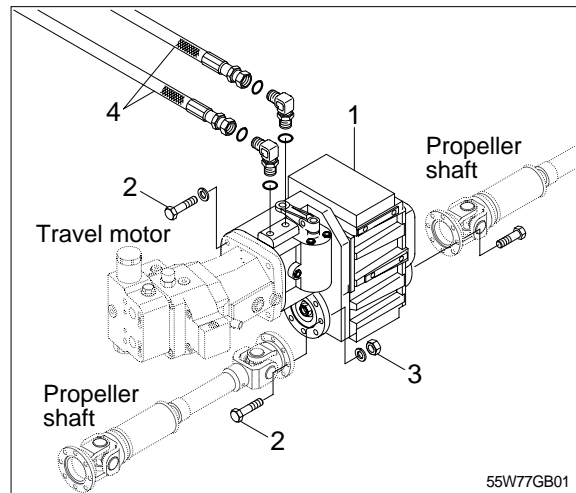

2. INSTRUCTIONS

The efficiency and continued operation of mechanical units depend on constant and correct maintenance and also on efficient repair work, should there be a break-down or malfunction. The instructions in this manual have been based on a complete overhaul of the unit. However, the mechanic must decide whether or not it is necessary to dismantle the individual components when only partial repair work is needed. The manual provides a quick and sure guide which, with the use of photographs and diagrams illustrating the various phases of the operations, allows to perform accurate work to take place.

Therefore all the information needed for correct disassembly, the relative check and assembly of each individual component, has been written down.

In order to remove the different unit from the vehicle, the manuals provided by the vehicle manufacturer should be consulted. In describing the following operations it is presumed that the unit has already been removed from the vehicle.

1) IMPORTANT

Throughout the phases of repair or maintenance work it is advisable to use proper equipment such as : Trestles or supporting benches, plastic or copper hammers, appropriate levers, extractor and specific spanners or wrenches. So that the work is facilitated and the working surfaces and the operators themselves are protected. Before going on to disassemble the parts it is best to thoroughly clean the unit, removing any encrusted or accumulated greases and then drain the oil through the oil-draining plug.

2) INTRODUCTORY REMARKS

All the disassembled mechanical units should be thoroughly cleaned with appropriate products and then restored or replaced if damage, wear, cracking or seizing have occurred.

In particular, thoroughly check the state of all moving parts (Bearings, gear, crown wheel and pinion, shaft) and sealing parts (O-ring, oil shield) which are subject to major stress and wear. In any case it is advisable to replace the seals every time a component is overhauled or repaired. During assembly the sealing rings must be lubricated on the sealing edge. In the case of the crown wheel and pinion, replacement of one component requires the replacement of the other one.

During assembly the prescribed pre-loading and backlash of the parts must be maintained.

3) MAINTENANCE AND REPAIR

We have compiled these instructions for maintenance and repair in order to facilitate any such work on the DANA components differential units and change units. The drawings of any special tools required for maintenance and repair work can be bought directly from us. Spare parts can be ordered either through the vehicle manufacturer or to us directly.

4) LUBRICANT SPECIFICATIONS

SAE 85W-90(API GL-5)

3. STRUCTURE

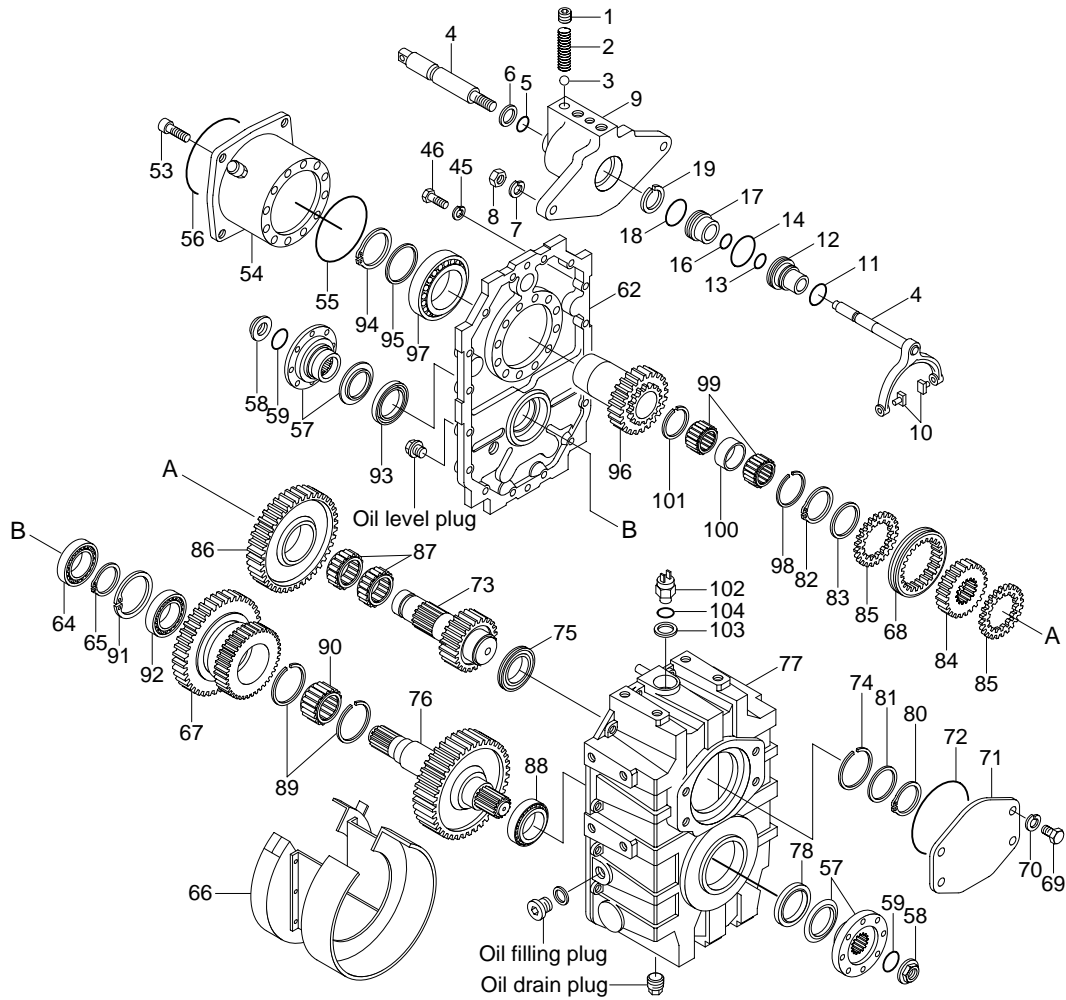

55W77GB02

1 Dowel	20 Gear selector rod	69 Screw	87 Needle cage
2 Spring	52 Spacer ring	70 Spring washer	88 Bearing
3 Ball	53 Screw	71 Cover	89 Snap ring
4 Rod	54 Motor carrier	72 O-ring	90 Needle bearing
5 O-ring	55 O-ring	73 Input shaft	91 Snap ring
6 Scraper ring	56 O-ring	74 Snap ring	92 Bearing
7 Spring washer	57 Flange	75 Bearing	93 Seal ring
8 Nut	58 Nut	76 Output shaft	94 Snap ring
9 Cylinder	59 O-ring	77 Reduction unit	95 Piece
11 O-ring	60 Screw	78 Seal ring	96 Input coupling
12 Guide bushing	61 Spring washer	79 Roller bearing	97 Bearing
13 O-ring	62 Cover	80 Snap ring	98 Circlip
14 O-ring	63 Sliding shoe	81 Washer	99 Needle cage
15 Complete piston	64 Bearing	82 Snap ring	100 Piece
16 O-ring	65 Snap ring	83 Shim washer	101 Snap ring
17 Piston	66 Regulator guard	84 Coupling	102 Safety microswitch
18 O-ring	67 Double gear	85 Synchronising ring	103 Lock washer
19 Snap ring	68 Coupling	86 Gear	104 O-ring

4. DISASSEMBLY AND ASSEMBLY

1) GENERAL

- (1) Enter match marks before removing the gear box.
- (2) Do not use O-ring after removal.
- (3) In case removed parts are left as disassembly, rust may be occurred in the parts by moisture and dust.

When work is stopped inevitably, be careful so that rust and dust may not to be accumulated.

2) DISASSEMBLY THE GEAR BOX

The order of disassembly for gear box are explained hereunder.

Perform assembling in reverse order or disassembly.

- (1) After lifting gear box assembly with eye-bolt, fix gear box using left and right tap.

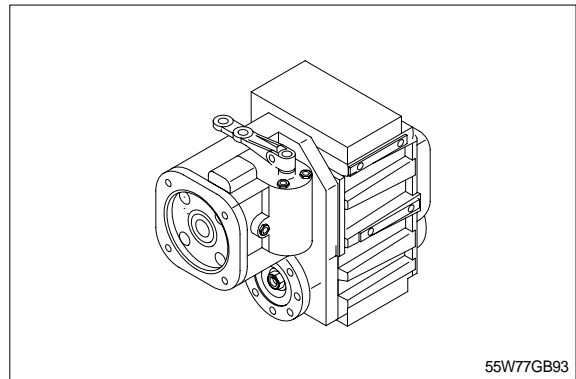

- (2) Remove oil filling plug.
Plug tightening torque : $16\text{kgf} \cdot \text{m}$ ($115.7\text{lb} \cdot \text{ft}$)

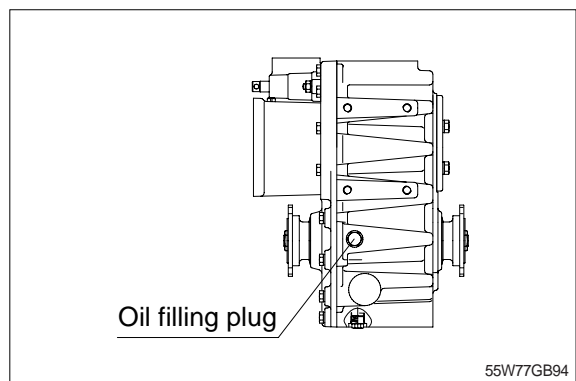

- (3) Remove oil level check plug.
Plug tightening torque : $16\text{kgf} \cdot \text{m}$ ($115.7\text{lb} \cdot \text{ft}$)

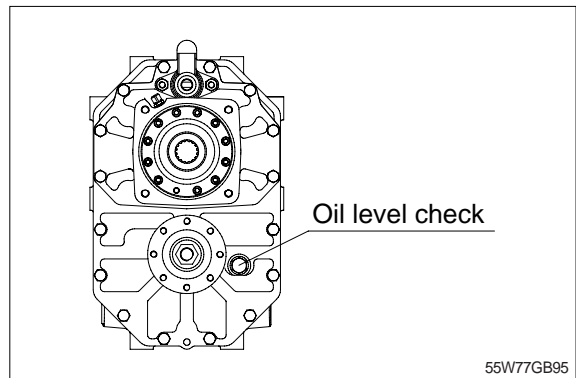

- (4) Remove the drain plug(Figure on the right)
Plug tightening torque : 16kgf · m(115.7lbf · ft)

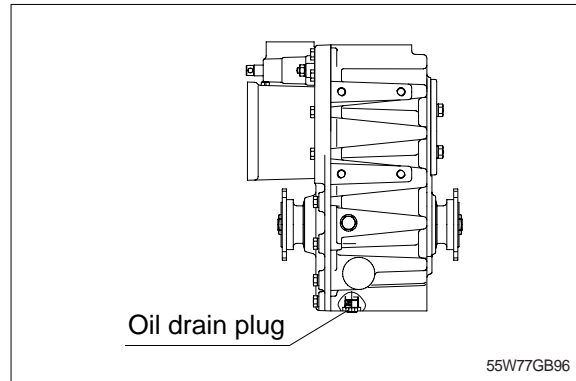

- (5) Remove hydraulic motor core.
Plug tightening torque : 16kgf · m(115.7lbf · ft)

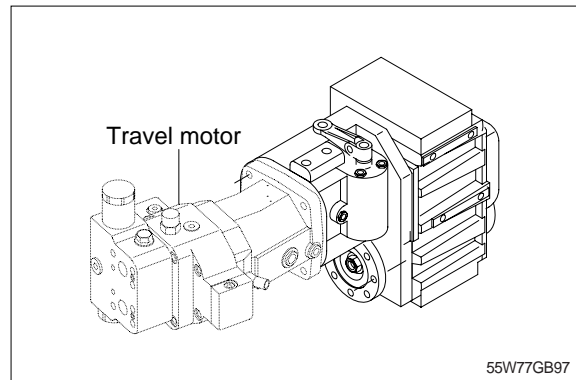

- (6) Remove the dowel and pull out the spring (2) and the ball(3).
※ Use a magnet rod.

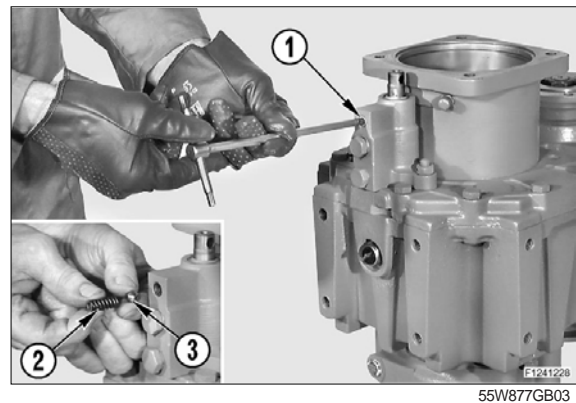

- (7) Remove the safety microswitch(102).

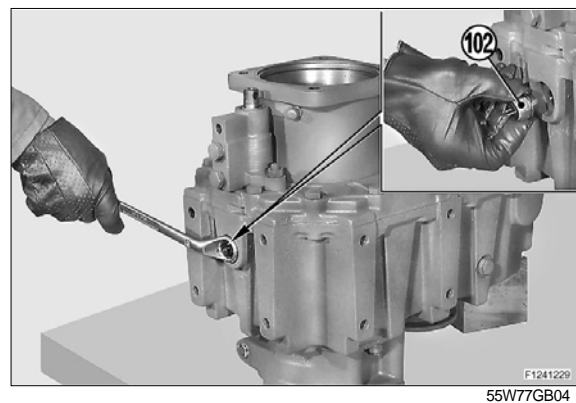

(8) Double effect gearshift cylinder only

Loosen and remove the gear engagement rod(4).

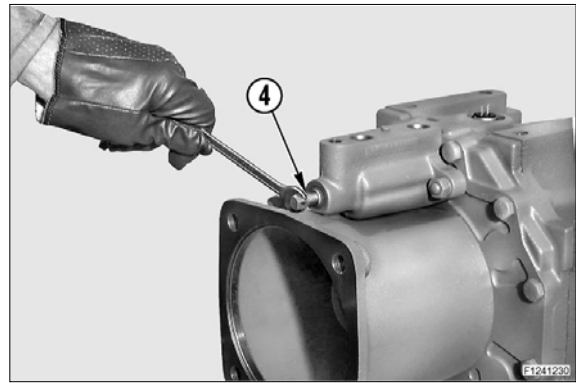

55W77GB05

(9) Loosen and remove the check nuts(8) and spring washers(7) of the gearshift cylinder assembly(9).

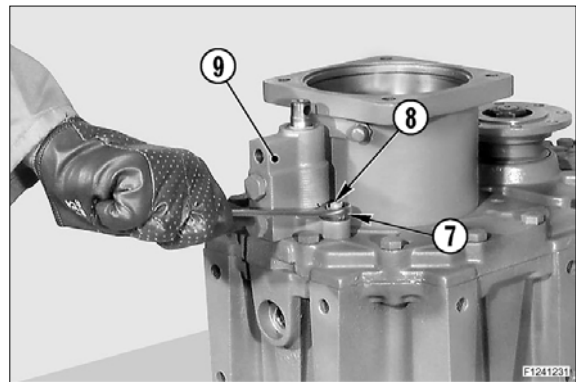

55W77GB06

(10) Partly lift the cylinder assembly(9) and lift the guide bushing(10) of the gear selector rod(20).

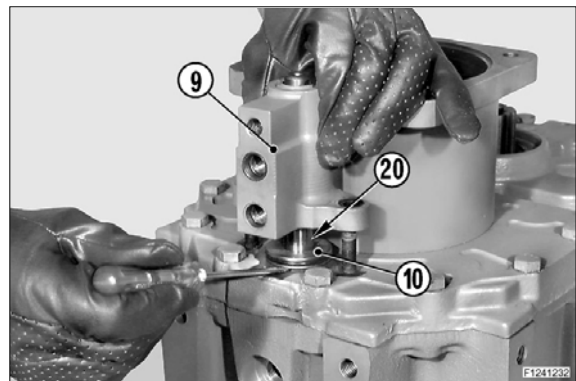

55W77GB07

(11) Lift both the gear selector rod(20) and the cylinder(9) at the same time; remove the cylinder.

※ To be able to extract the cylinder, you will need to direct the gear selector rod outwards.

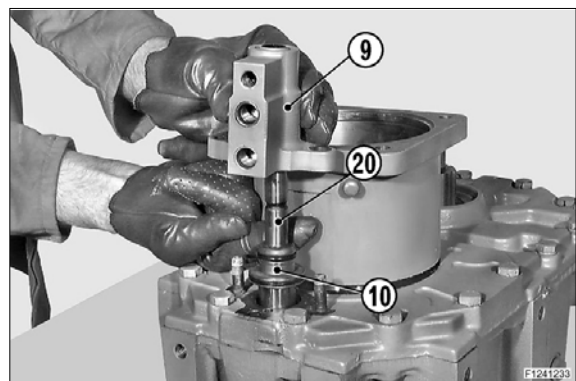

55W77GB08

(12) Gearshift cylinder only

Remove the snap ring(19) and pull out the whole piston(15) and the guide bushing (10) together with the O-rings.

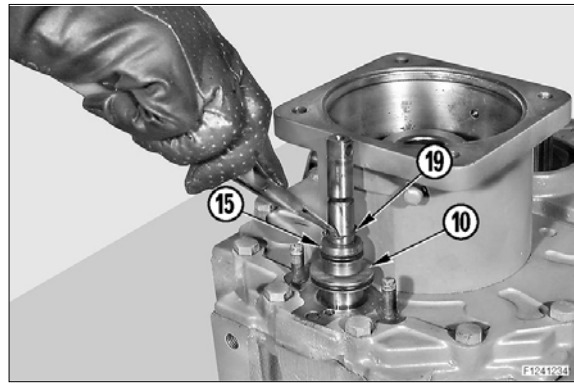

55W77GB09

(13) Remove screws(53) and pull out the motor carrier(54) together with the O-rings (55), (56).

※ Mark both carrier position in relation to the reduction body and the hole "A", without screw, provided for oil flow (on the carrier).

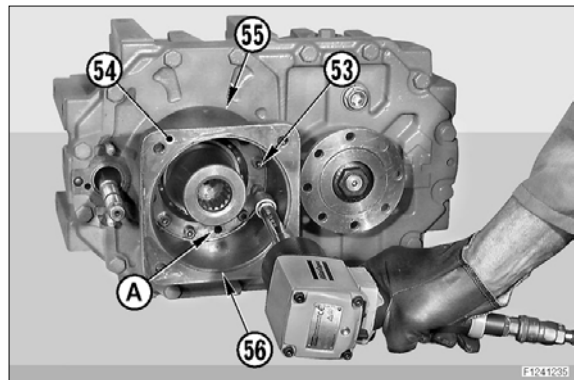

55W77GB10

(14) Apply tool T1A(or T1B) onto the flange (57) and engage it so as to prevent shaft rotation.

Loosen and remove the nut(58), the O-ring(59) and the flange(57).

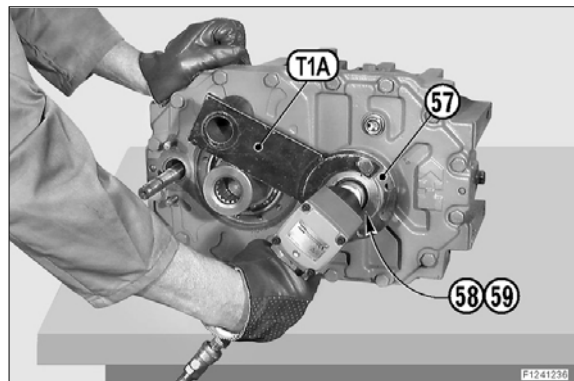

55W77GB11

(15) Loosen and remove the check screws(60) of the cover(62) and the spring washers (61).

※ Note down that washers(61) are only fitted where cover top is rough.

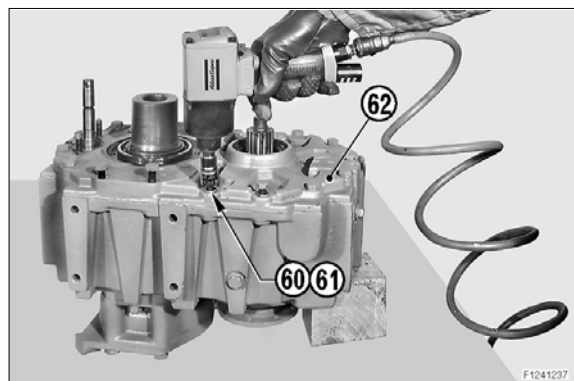

55W77GB12

(16) Introduce a driver made of tender material into the two opposing slots, alternately; move and partially lift the cover(62).

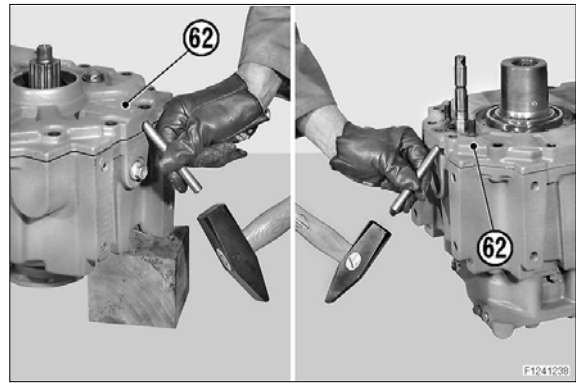

55W77GB13

(17) Using two levers, disengage the whole cover(62) from the reference pins and remove it.

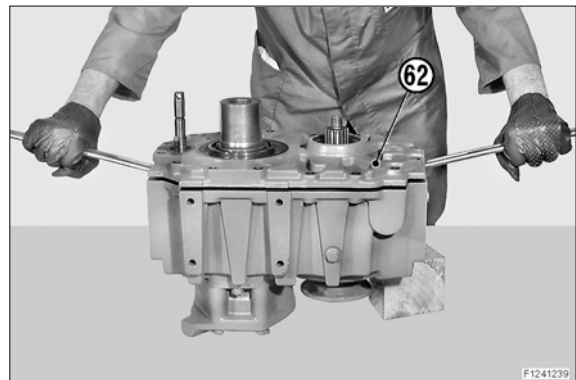

55W77GB14

(18) Remove the gear selector rod(20) together with fork and sliding shoes(63).

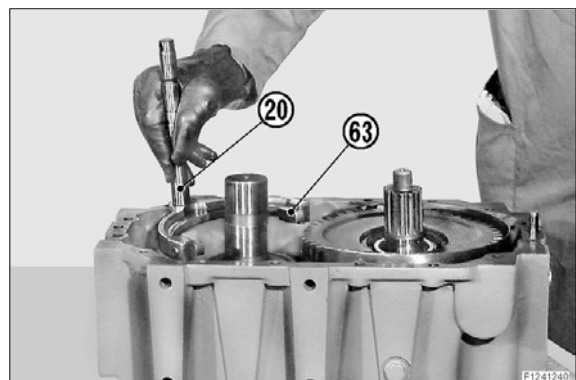

55W77GB15

(19) Using a puller, remove the bearing(64). Remove the snap ring(65).

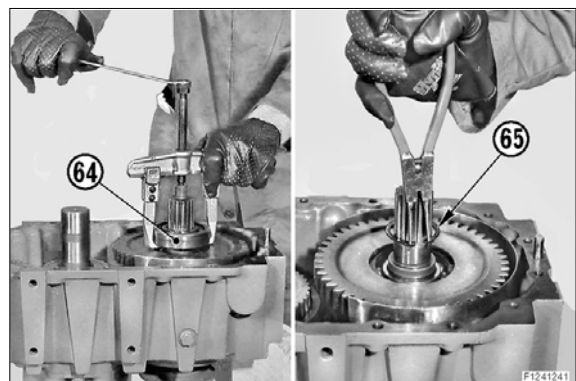

55W77GB16

(20) Using two levers, lift both the flow regulator guard(66) and the double gear(67) at the same time.

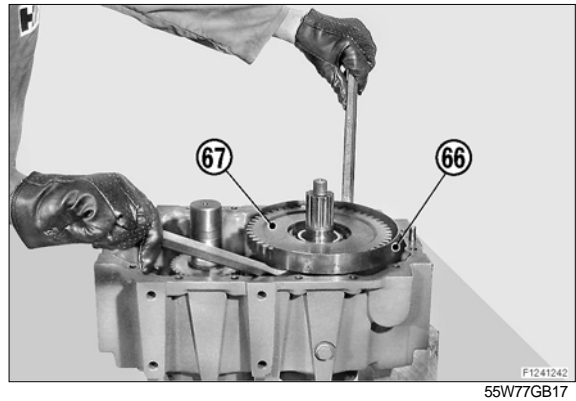

(21) Remove the whole gear(67) and the flow regulator guard(66).

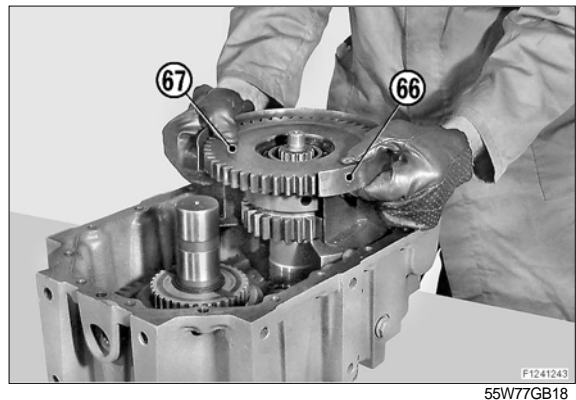

(22) Remove the sliding coupling(68).

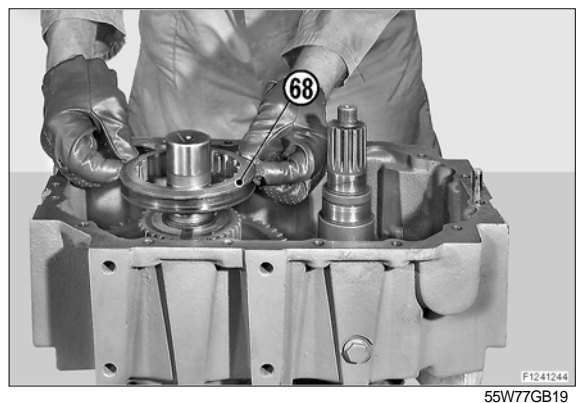

(23) Turn the unit up side down, lay it on some blocks and remove the second flange(57)- if fitted-by carrying out the same procedure adopted for flange one.

※ This operation is not required in reduction units flanged directly on the axle.

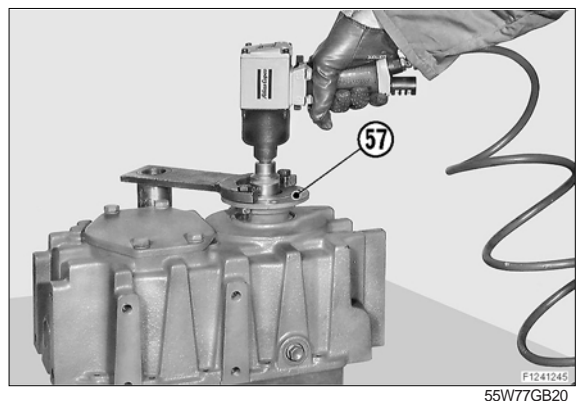

(24) Loosen screws(69) and washers(70);
remove the cover(71) and the O-ring(72).

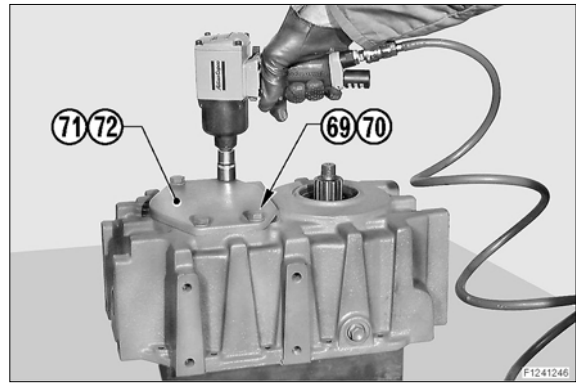

(25) Completion of disassembly

※ The illustrations refer to a gearshift with negative brake but the disassembly procedure applies to all versions, except for the operations illustrated in the notes.

(26) Place the gearshift on its side and hit the input shaft(73) with a plastic hammer until it pushes outwards by a few millimeters.

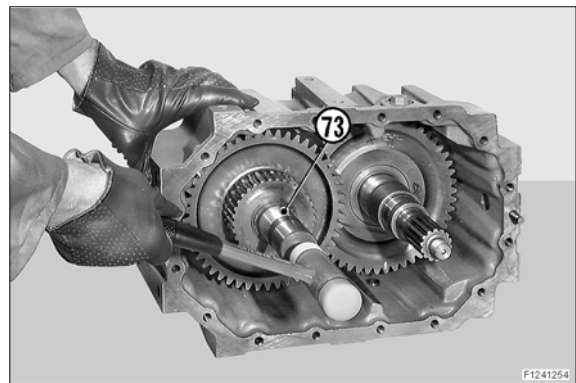

(27) Remove the snap ring(74) of bearing(75).

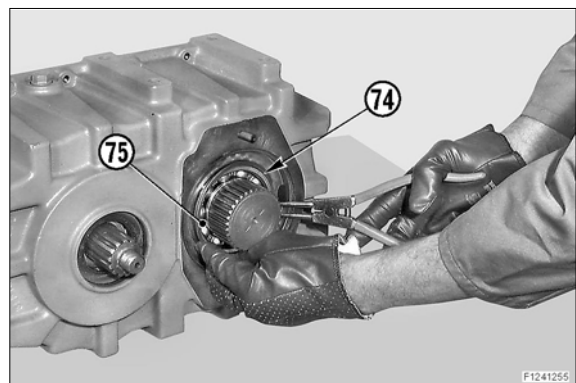

(28) Using a plastic hammer, extract the complete input shaft(73).

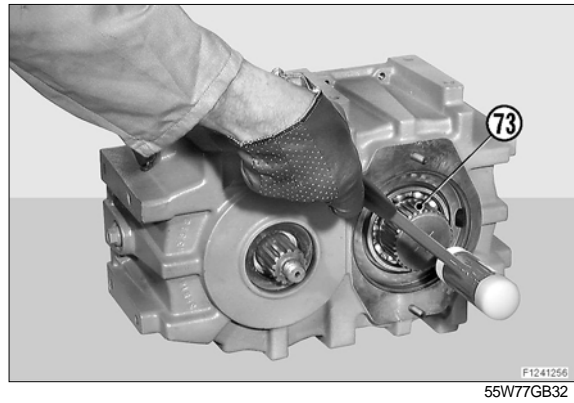

(29) Extract the whole output shaft(76) using a plastic hammer.

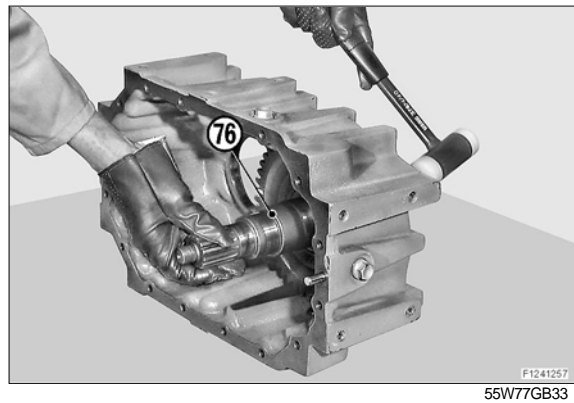

(30) Remove the snap ring(78) from the body of the reduction unit(77).

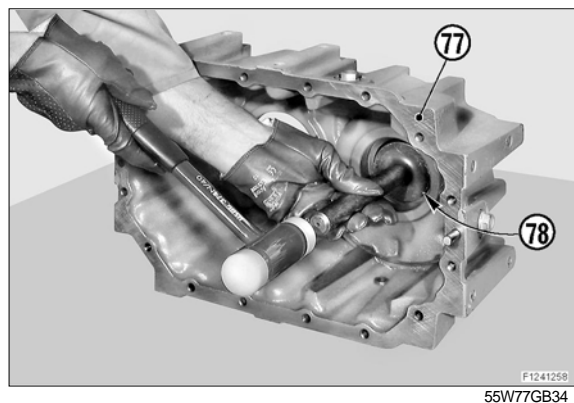

(31) Using driver T2, extract the outer ring of the roller bearing(79) from the reduction unit(77).

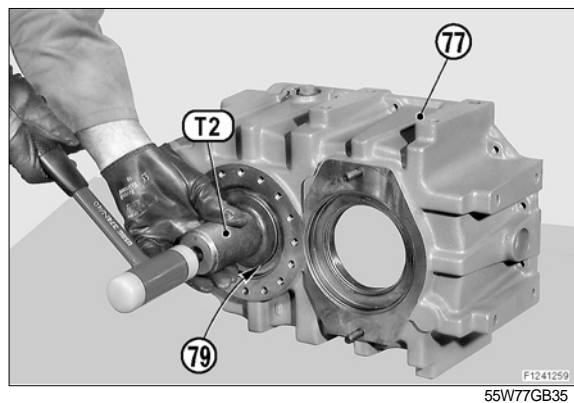

(32) Remove the snap ring(80) and the distance washer(81): using a separator, remove the bearing(75) from the input shaft(73).

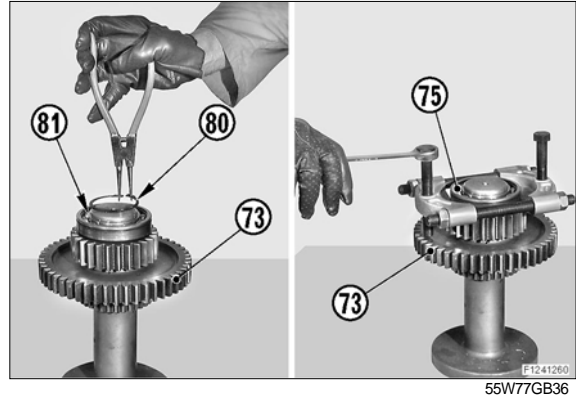

(33) Remove the snap ring(82) from the input shaft(73).

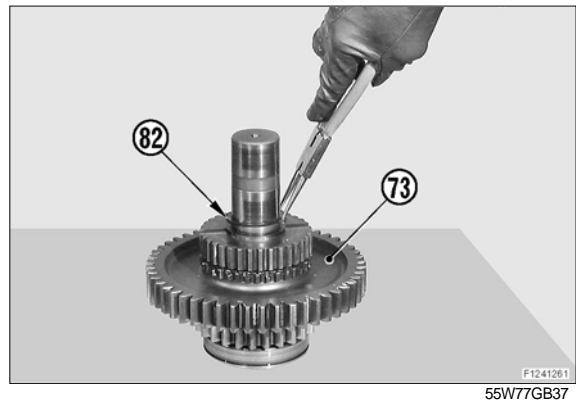

(34) Remove the shim washer(83) and the toothed coupling(84).

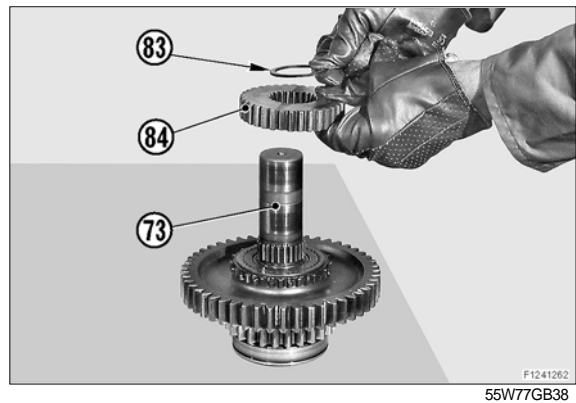

(35) Remove the synchronising ring(85), together with gear(86) and needle cages (87), from the input shaft(73).

※ Accurately check the couplings for signs of wear.

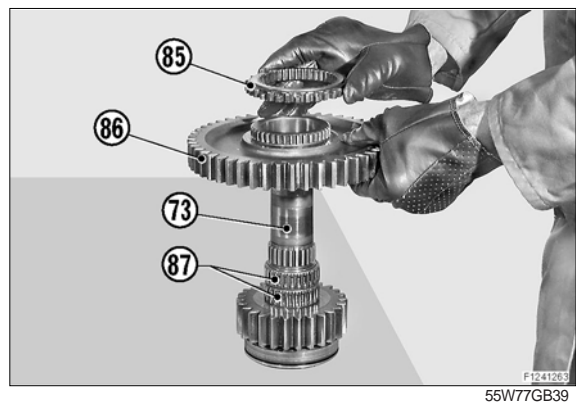

(36) Using a separator, remove the bearing (88) from the output shaft.

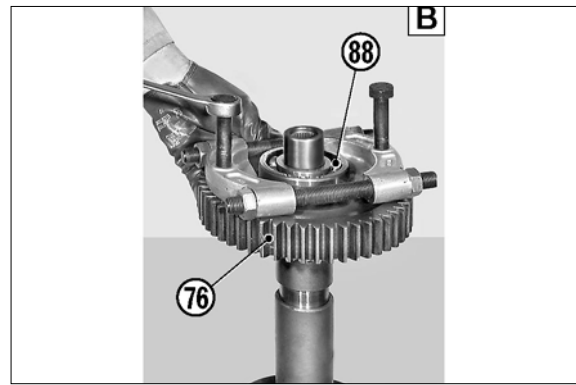

55W77GB40

(37) Using a puller, remove the inner ring of the roller bearing (79) from the output shaft (76).

- ※ 1 - Note down direction of assembly.
- 2 - Protect the head of the shaft with a pad.

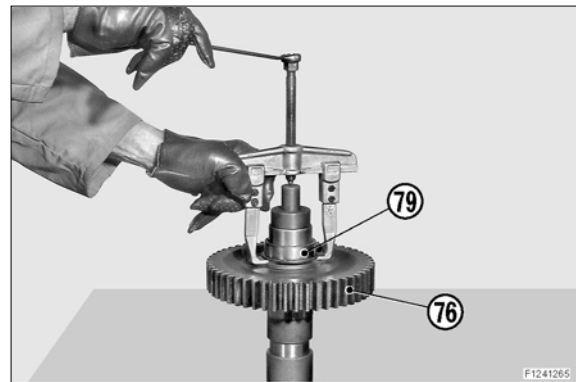

F1241265
55W77GB41

(38) From the double gear (67), remove snap ring (89) and needle bearing (90), as well as snap ring (91) and bearing (92). Remove the second snap ring (89) only if necessary.

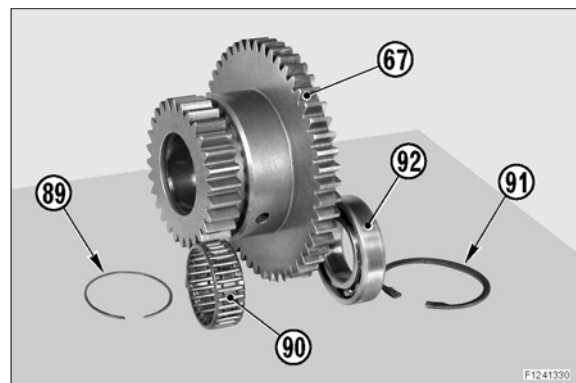

F1241330
55W77GB42

(39) Remove the sealing ring from the cover (62).

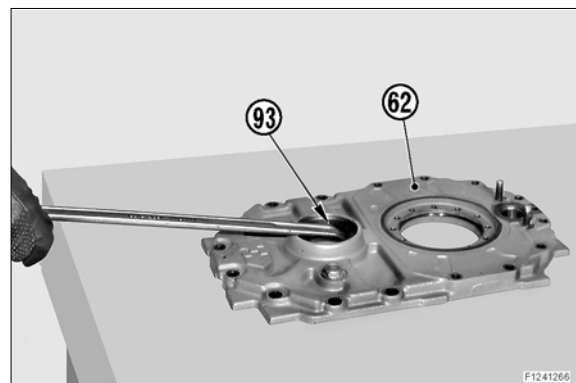

F1241266
55W77GB43

(40) Remove the snap ring(94) and pull out the distance piece(95).

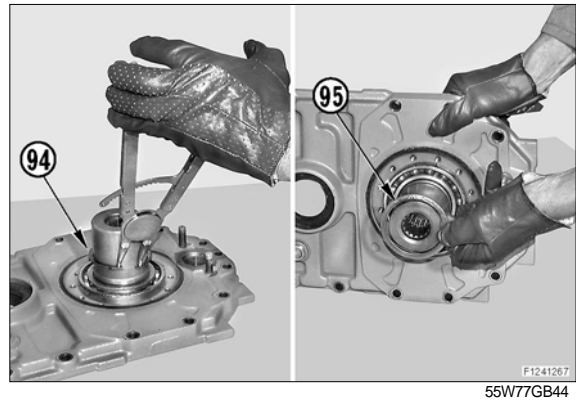

(41) Using a plastic hammer, remove the input coupling(96).

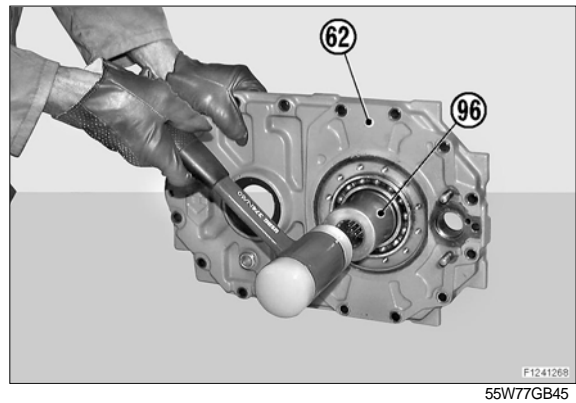

(42) Remove the synchronising ring(85) from the coupling(96).

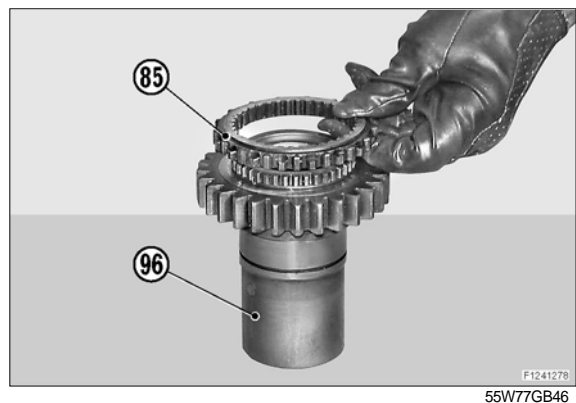

(43) Remove bearing(97) from cover(62).
※ If necessary, turn cover upside down and hammer lightly with a plastic hammer.

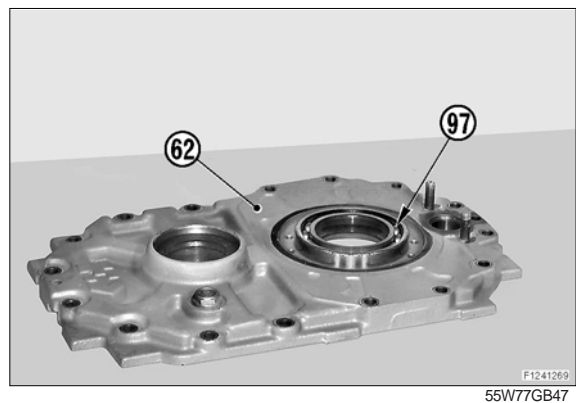

- (44) Remove the circlip(98), the needle cages(99) and the distance piece(100) from the input coupling(96).

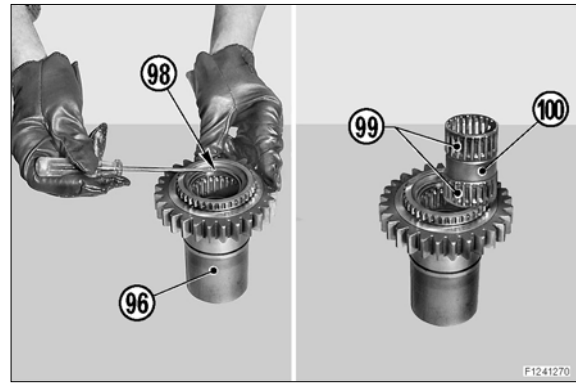

(45) Only if necessary

Rotate snap ring(101) until one end corresponds to hole "A" in the coupling (96); extract the ring using a driver.

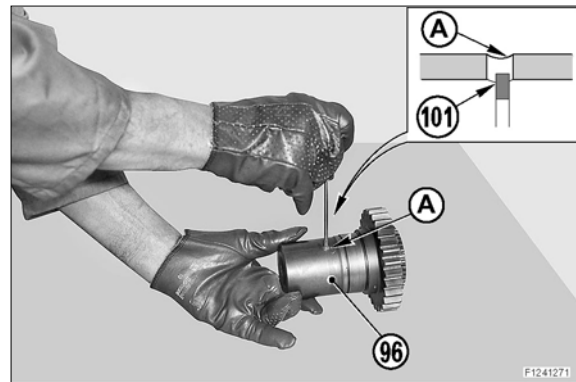

- (46) Remove the dust scraper ring(6) and the rod's O-ring(5) from the gearshift cylinder (9).

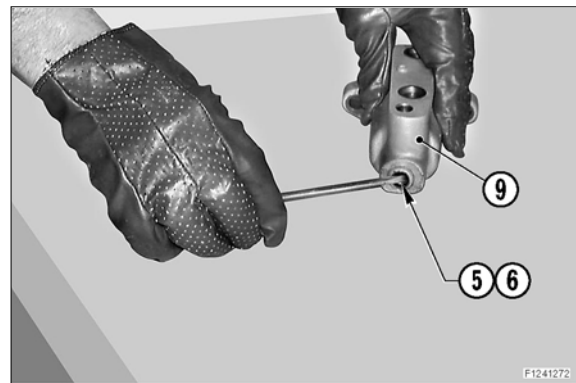

(47) Disassembling the double effect gear cylinder

Using a driver whose diameter is the same size as the control rod(4), extract the 2nd gear engagement piston(22) and the internal piston(24) from the cylinder (9).

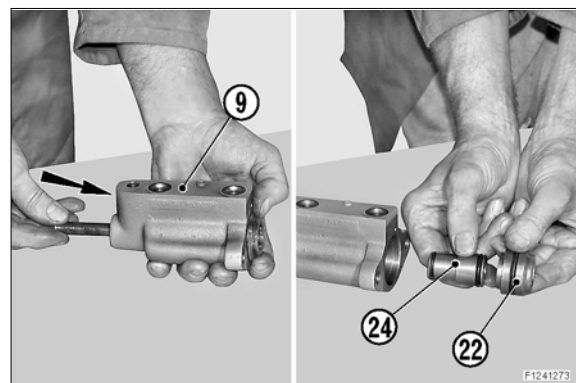

- (48) Remove the snap ring(27) and shim(28).
※ Note down direction of assembly of shim.

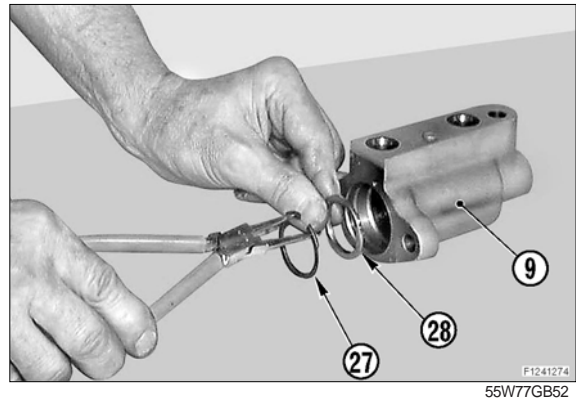

- (49) Pull out the 1st gear engagement piston (29).

- ※ The O-rings and the dust scraper ring must be replaced every time the unit is disassembled.

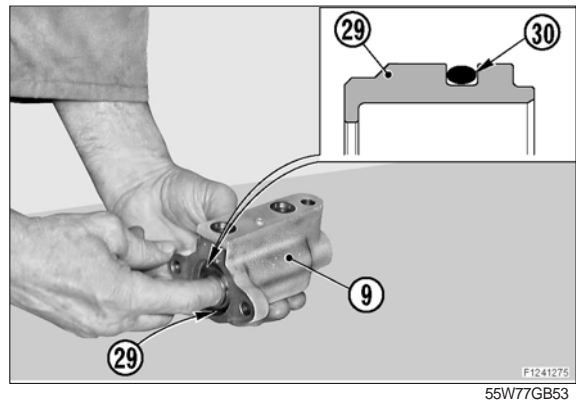

3) ASSEMBLY THE GEAR BOX

- (1) Replace the O-ring(30) and fit the 1st gear engagement piston(29) into the cylinder(9).

※ Lubricate the O-ring.

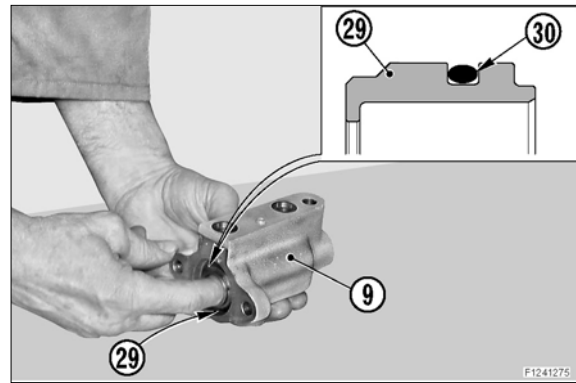

- (2) Fit the shim(28) and the snap ring(27).

※ Accurately check that bevelled portion of shim(28) faces the inner part of the cylinder.

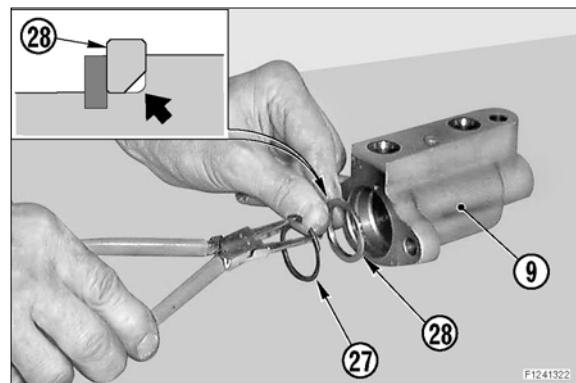

- (3) Replace O-rings(23), (25) and (26) and fit the 2nd gear engagement piston(24) and the internal piston(24) into the cylinder(9).

※ Lubricate the O-rings.

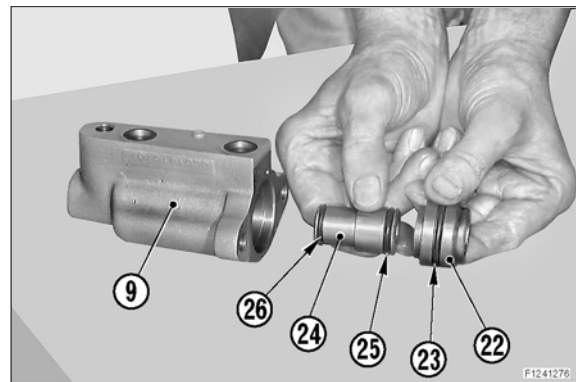

(4) Assembling the reduction unit

Fit the snap ring(101)-if previously removed-into the input coupling(96).

※ Use hole "A" to check that the ring(101) has correctly been positioned into its seat.

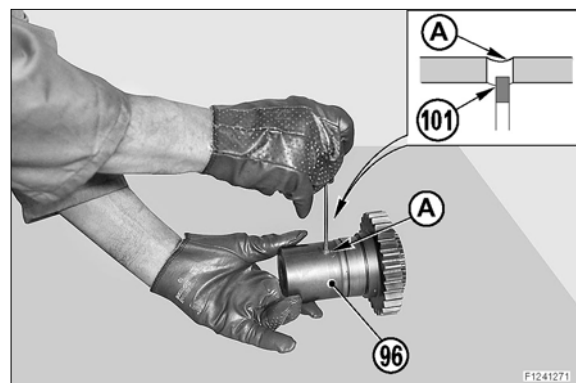

- (5) Fit the needle cage(99), distance piece (100) and second needle cage(99) into the input coupling(96).
Fit the snap ring(98).
※ Grease the needle cages(99).

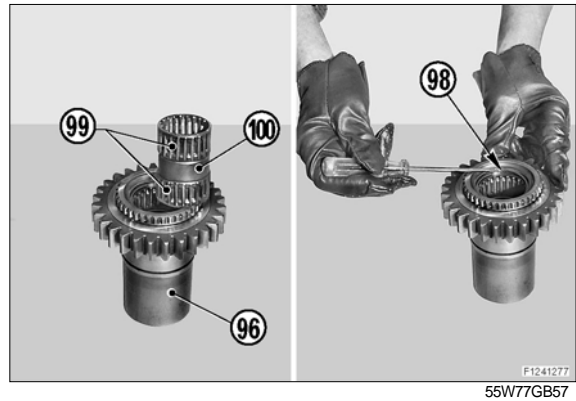

- (6) Fit the synchronising ring(85) onto the input coupling(96).

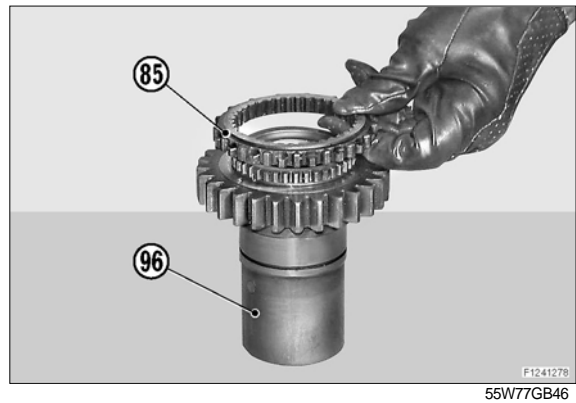

- (7) Using a plastic hammer, push the bearing (97) into its seat in the cover(62).
※ Distribute hammer blows all around the rim.

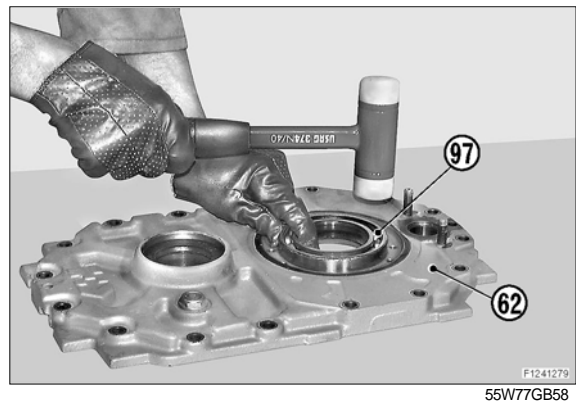

- (8) With a plastic hammer, fit the bearing(64) into the cover(62).

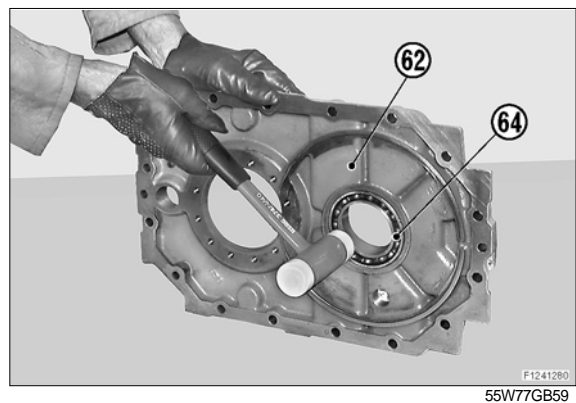

(9) Fit the input coupling(96) into the bearing (97).

※ Lightly hammer all around the rim.

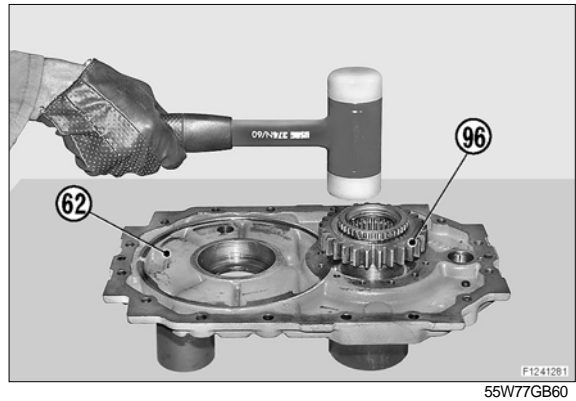

(10) Turn the cover(62) upside down and complete assembly by fitting the distance piece(95) and snap ring(94).

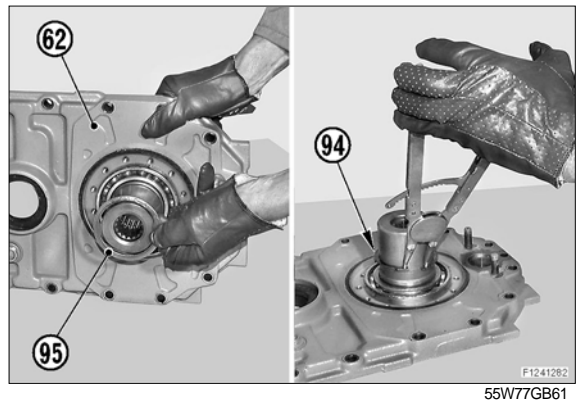

(11) Using a driver, fit the sealing ring(93).

※ Grease the outer surface of the ring(93) and check direction of assembly.

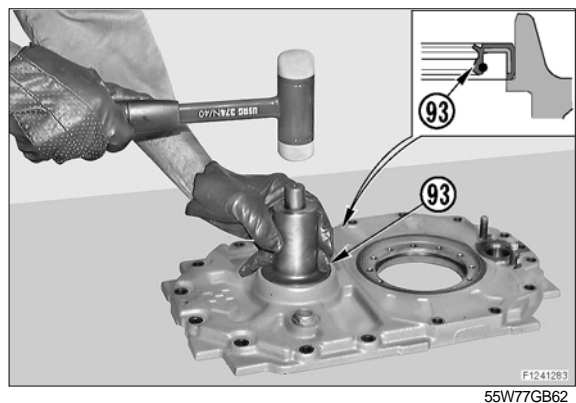

(12) Using a driver, fit the inner ring of the roller bearing(79) onto the output shaft(70).

※ Accurately check direction of assembly.

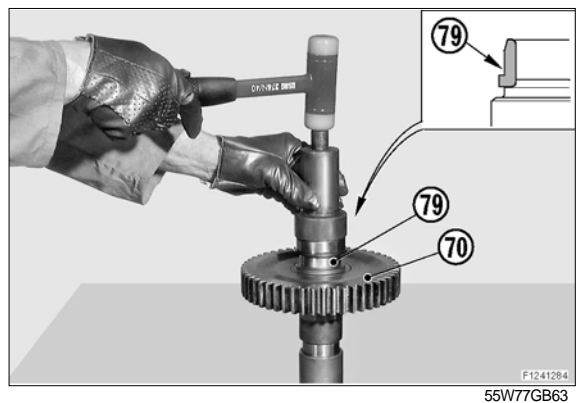

(13) Using a driver, fit the bearing(88) onto the output shaft(76).

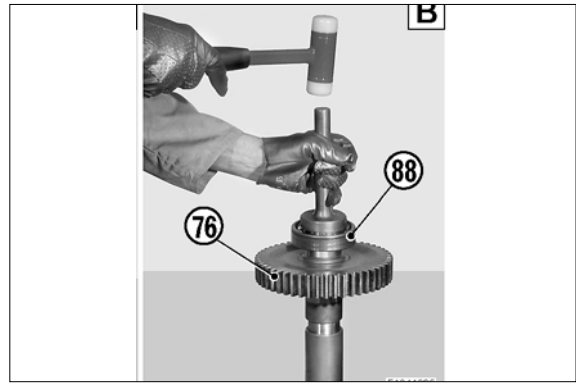

55W77GB64

(14) Fit the needle cages(87), the gear(86) and the synchronising ring(85) onto the input shaft(73).

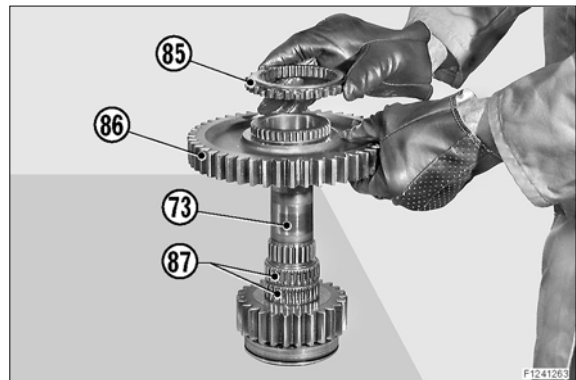

55W77GB39

(15) Fit the toothed coupling(84), shim(83) and snap ring(82) onto the input shaft(73).

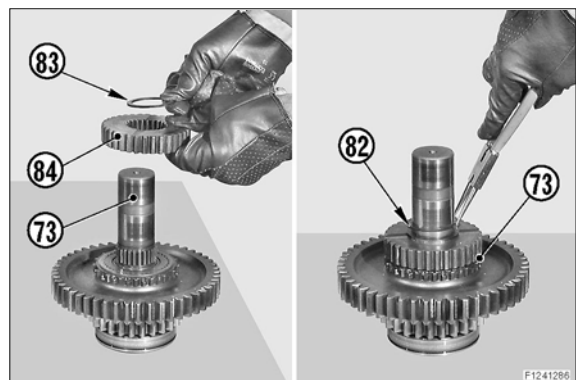

55W77GB65

(16) Turn the shaft(73) upside down and using a driver, fit the bearing(75) on.

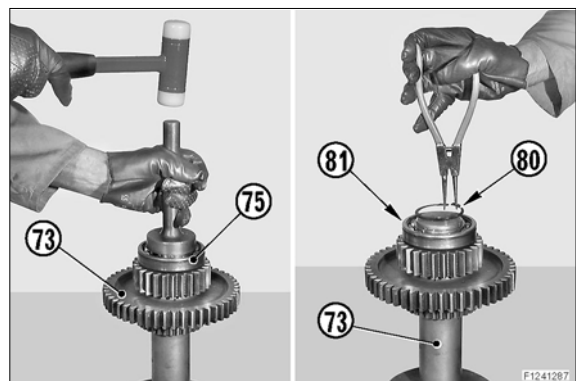

55W77GB66

(17) Using a plastic hammer, fit the outer ring of the roller bearing(79) into the body of the reduction unit(77).

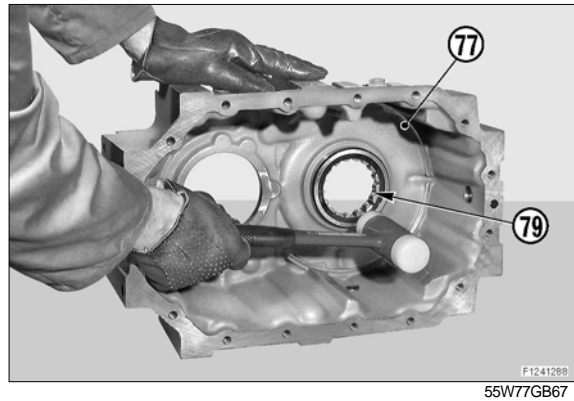

(18) Using a driver, fit the sealing ring(78) into the body of the reduction unit(77).

- ※ 1 Lubricate the outer surface of the ring(78).
- 2 Accurately check the direction of assembly.

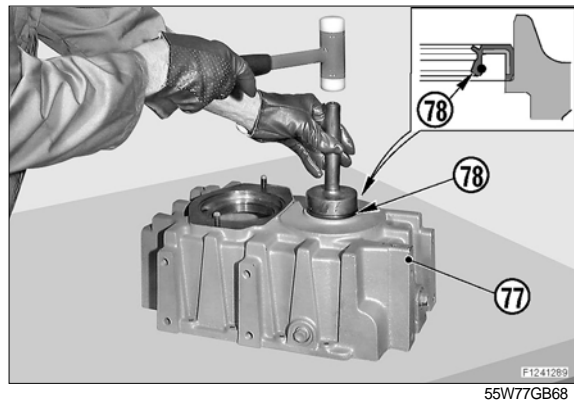

(19) Fit the whole output shaft(76) into the body of the reduction unit(77).

- ※ Make sure that the bearing is properly engaged in its seat in the body of the reduction unit.

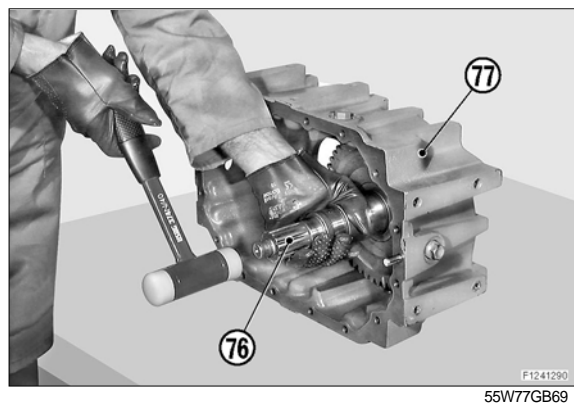

(20) Using a plastic hammer, introduce the input shaft(73) until the seat of the snap ring(74) of bearing(75) just out of the body of the reduction unit(77).

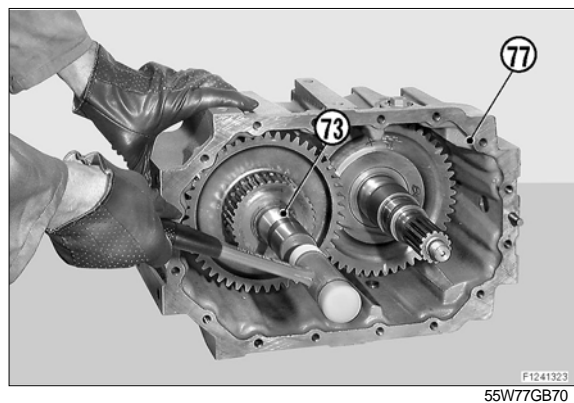

(21) Fit the snap ring(74) onto the bearing(75).

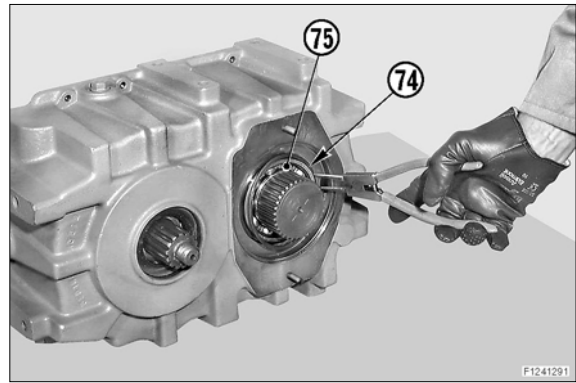

(22) With a plastic hammer, push in the snap ring(74) of bearing(75) so as to engage it.

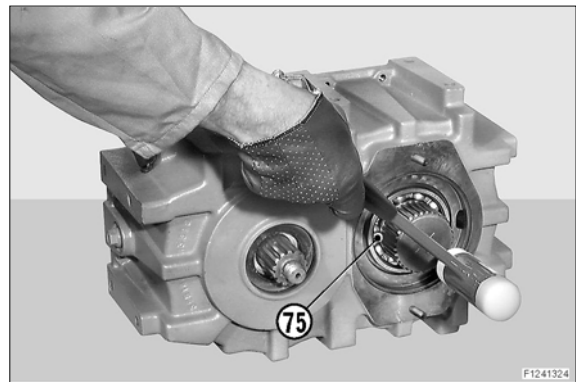

(23) Position the O-ring(72) on the cover(71).

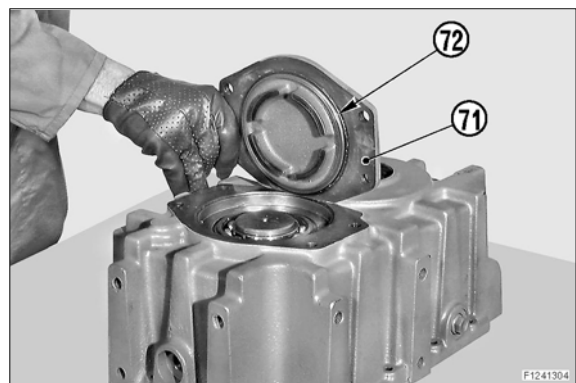

(24) Fit the cover(71) onto the body of the reduction unit(77) and lock it into position with the screws(69) and the spring washers(70).

Screws tightening torque : 8.8~9.1kgf · m
(63.4~65.6lbf · ft)

※ Tighten screws alternately and using the criss-cross method.

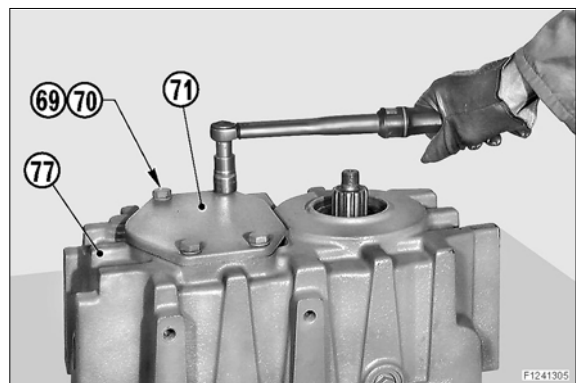

(25) Completion of assembly

Install the flange(57) for the second exit, the O-ring(59), and the nut(58) treated with loctite 243 on the output shaft.

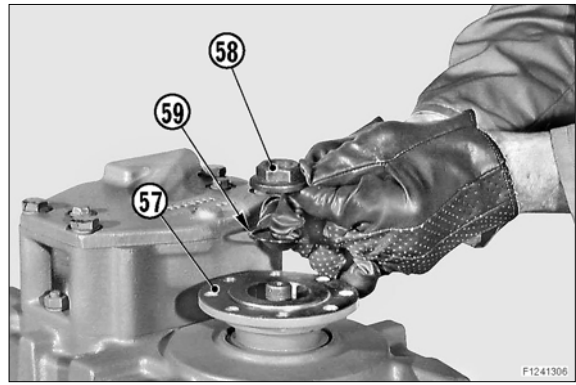

(26) Using tool T1A(or T1B) tighten the nut(58).

Torque wrench setting : 26.5~28.6kgf · m
(192~207lbf · ft)

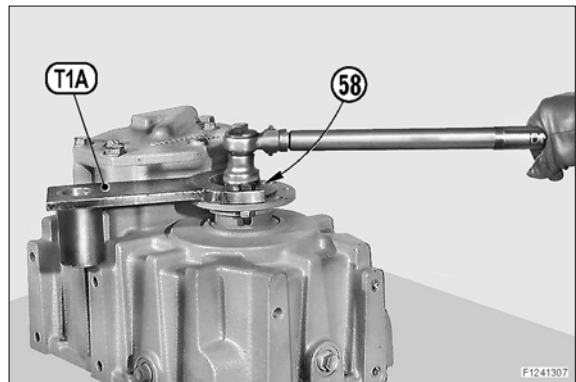

(27) Turn the reduction unit up side down and fit the sliding coupling(68) onto the input shaft(73).

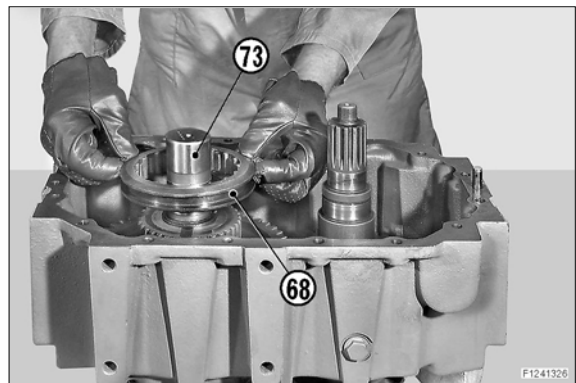

**(28) Fit the bearing(92), the snap ring(91), the needle bearing(90), and the snap ring(89) in the double gear(67).
Lubricate the needle bearing with grease.**

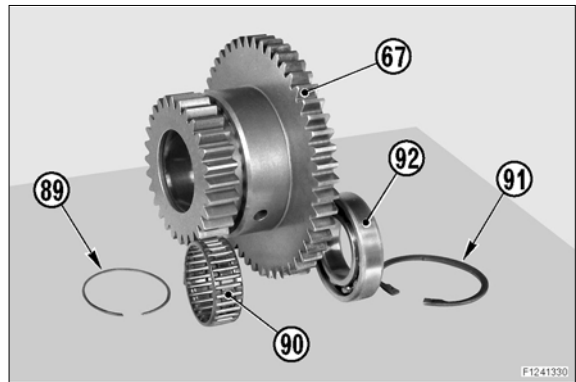

(29) Fit the gear(67), complete with flow regulator guard(66), onto the output shaft.

- ※ Make sure that the anti-rotation stops of the guard are properly engaged on the ribs of the body of the reduction unit.

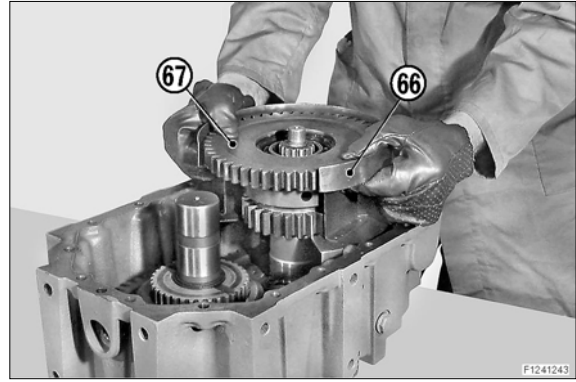

(30) Fit the snap ring(65) onto the output shaft (76).

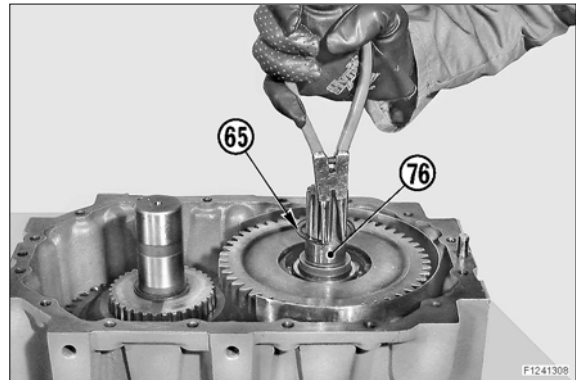

(31) Install the gear selector rod(20) together with fork and sliding shoes(63).

- ※ 1. Replace the sliding shoes if thickness is less than 11.3mm.
- 2. Make sure that the sliding shoes are engaged in the sliding coupling.

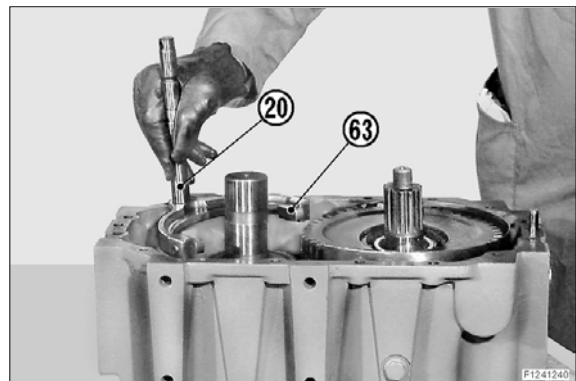

(32) Coat the coupling surface of the reduction body(77) with loctite sealant 510 and fit the cover(62) by centering the reference pins.

- ※ Make sure that the sealant forms a continuous film around the threaded holes.

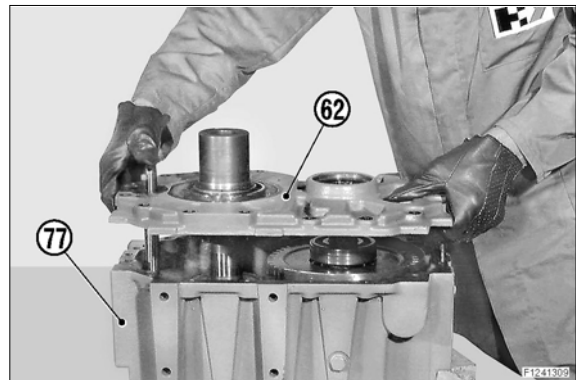

(33) With a plastic hammer, fasten the cover (62) to the reduction unit(67).

- ※ Hammer lightly and alternately all around the bearings.

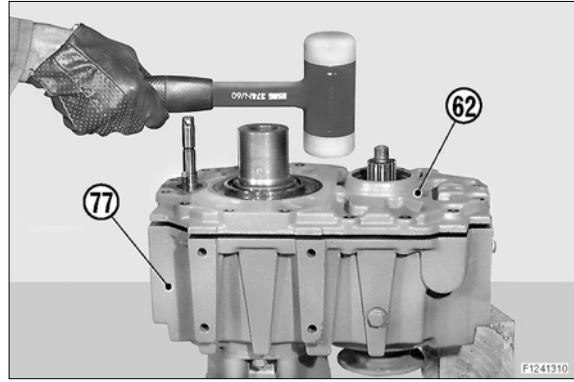

(34) Fit screws(60) on the input side; insert screws(60) and spring washers(61) on the output side.

Lock the cover by tightening the screws to a tightening torque of 5.0~5.2kgf · m (36.1~37.6lbf · ft).

- ※ Tighten alternately and using the criss-cross method. Start with the central portion.

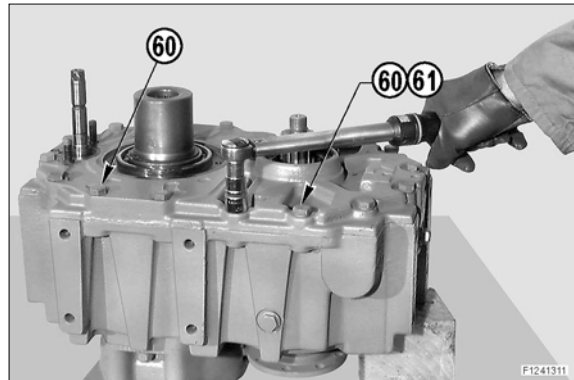

(35) Fit the flange(57), the O-ring(59) and the nut(58) coated with loctite 243 onto the output shaft(57).

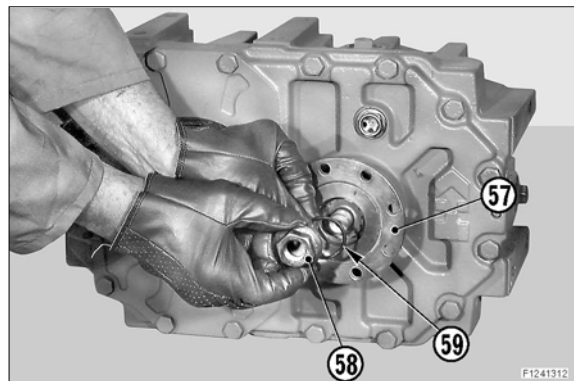

(36) Using tool T1A(or T1B), tighten the nut(58).

Torque wrench setting : 26.5~28.6kgf · m (192~207lbf · ft)

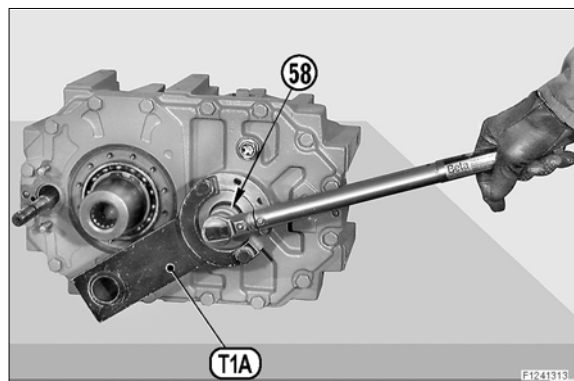

(37) Fit the O-ring(55) onto the motor carrier(54).

Install the carrier and lock it with screws(53). Tighten screws to 2.5~2.7 kgf · m (18.4~19.2lbf · ft).

※ Do not introduce any screw into oil flow hole "A" - the one you have marked during disassembly.

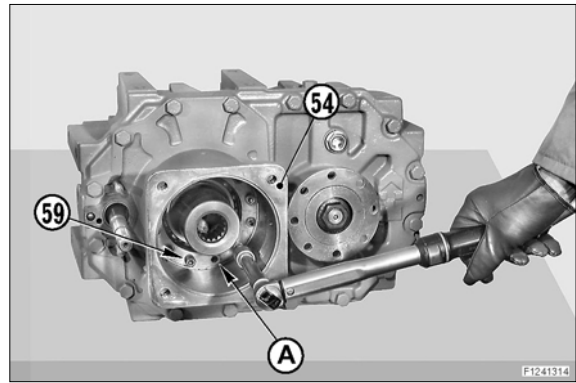

(38) Fit the O-rings(11), (13), (14) on the guide bush(12) and lubricate rings.

Fit the bush(12) onto the gear selector rod(20).

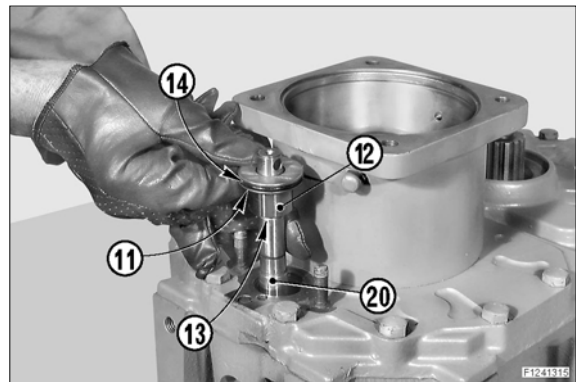

(39) Gearshift cylinder only

Fit the O-rings(16), (18) onto the piston (17) and lubricate rings.

Fit the complete piston(15) onto the gear selector rod(20) and engage it by means of the snap ring(19).

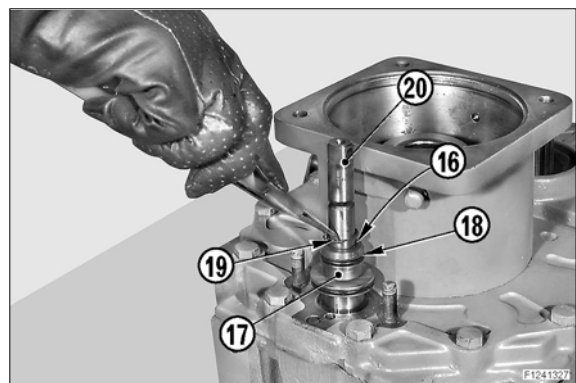

(40) Coat the coupling surface of the gearshift cylinder(9) with loctite 510; fit the cylinder on the gear selector rod(20).

※ Make sure that the sealant forms a continuous film around the locking holes.

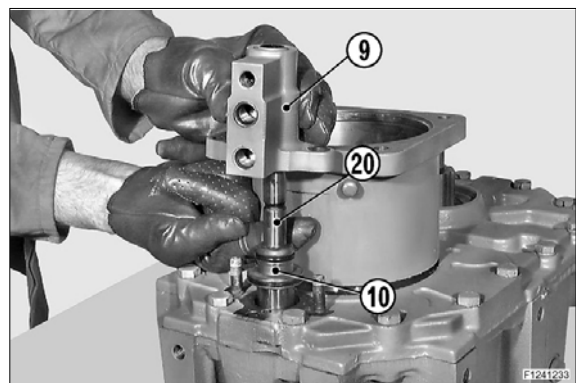

(41) Fit the spring washers(7) and screw the nuts(8); tighten to a torque of 5.0~5.2kgf · m (36.1~37.6lbf · ft).

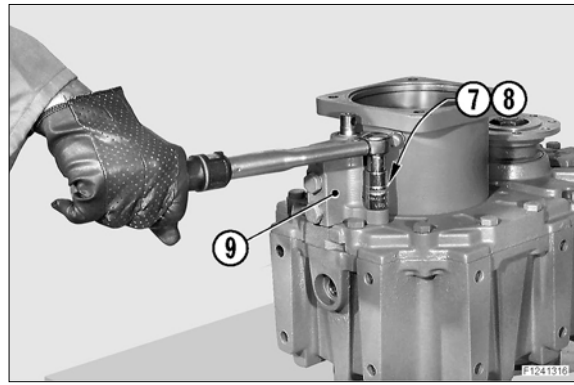

55W77GB88

(42) Introduce the ball(3) and spring(2) into the gearshift cylinder(9). Coat the dowel(1) with loctite 510 and screw it until it is level with the cylinder.

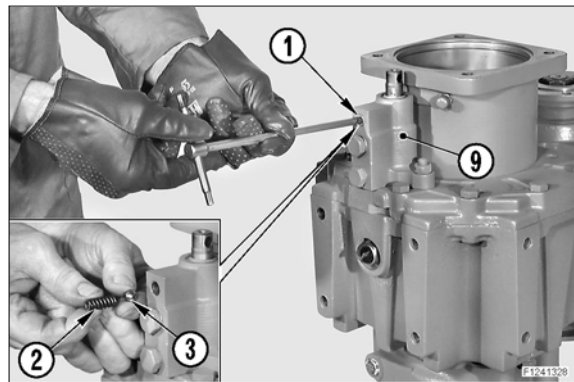

55W77GB89

5. SPECIAL TOOLS

1) T1

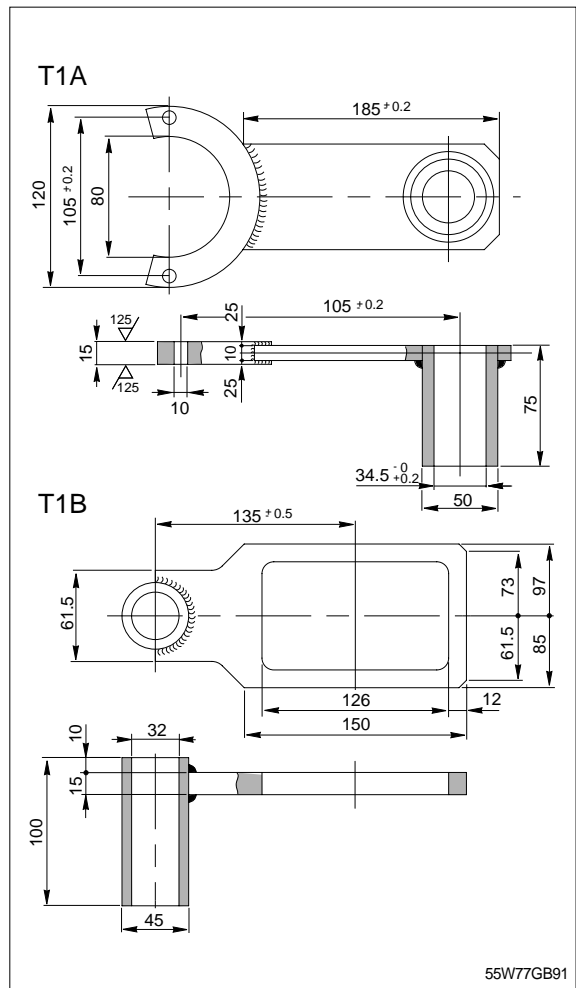

2) T2

