

GROUP 10 REAR AXLE

1. REMOVAL REAR AXLE

- 1) Rear axle mounting bolt and nut(1, M16)
 - Tightening torque : $29.7 \pm 4.5 \text{kgf} \cdot \text{m}$
($215 \pm 32.5 \text{lbf} \cdot \text{ft}$)
- 2) Propeller shaft mounting nut(2, M10)
 - Tightening torque : $7.4 \pm 1.5 \text{kgf} \cdot \text{m}$
($53.5 \pm 10.8 \text{lbf} \cdot \text{ft}$)
- 3) Wheel nut(3)
 - Tightening torque : $46 \pm 3 \text{kgf} \cdot \text{m}$
($333 \pm 21.7 \text{lbf} \cdot \text{ft}$)
- 4) Hose assy(4)
- 5) Rear axle weight : 195kg(430lb)

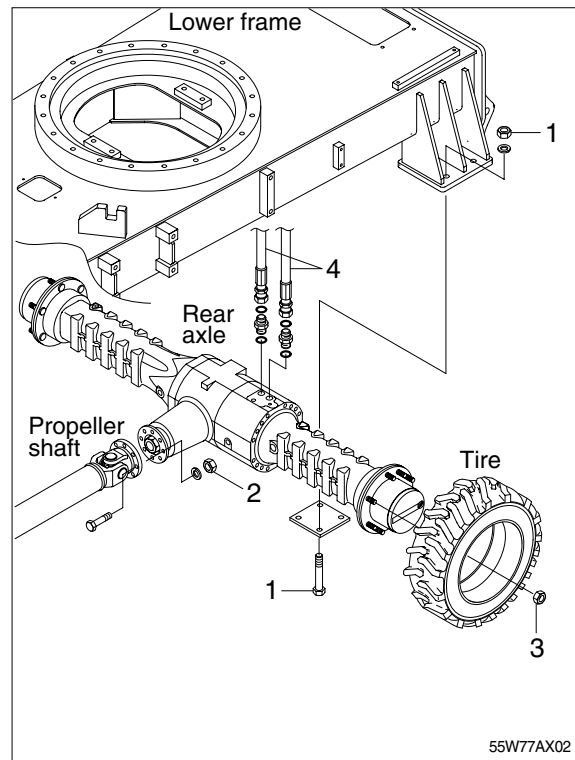

2. GENERAL INSTRUCTIONS

- 1) During all operations described in this manual, the axle should be fastened onto a trestle, while the other parts mentioned should rest on supporting benches.
- 2) When removing one of the arms, an anti-tilting safety trestle should be placed under the other arm.
- 3) When working on an arm that is fitted on the machine, make sure that the supporting trestles are correctly positioned and that the machine is locked lengthways.
- 4) Do not admit any other person inside the work area; mark off the area, hang warning signs and remove the ignition key from the machine.
- 5) Use only clean, quality tools; discard all worn, damaged, low-quality or improvised wrenches and tools. Ensure that all dynamometric wrenches have been checked and calibrated.
- 6) Always wear gloves and non-slip rubber shoes when performing repair work.
- 7) Should you stain a surface with oil, remove marks straight away.
- 8) Dispose of all lubricants, seals, rags and solvents once work has been completed. Treat them as special waste and dispose of them according to the relative law provisions obtaining in the country where the axles are being overhauled.
- 9) Make sure that only weak solvents are used for cleaning purposes; avoid using turpentine, dilutants and toluol-, xylol- based or similar solvents; use light solvents such as kerosene, mineral spirits or water-based, environment friendly solvents.
- 10) For the sake of clarity, the parts that do not normally need to be removed have not been reproduced in some of the diagrams.
- 11) The terms RIGHT and LEFT in this manual refer to the position of the operator facing the axle from the side opposite the drive.
- 12) After repair work has been completed, accurately touch up any coated part that may have been damaged.

3. BRAKE; SERVICE BRAKE, NEGATIVE BRAKE, 100% LOCKED

1) Disassembly

- (1) Connect an external pump to the union piece "P1" of the negative brake and introduce a pressure of 15 ± 3.0 bar to eliminate the pressure of the belleville washers.

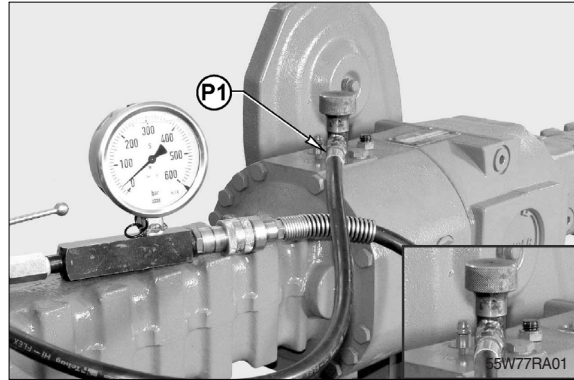

- (2) Loosen the unlocking screws(30) and remove both stop washers(32).

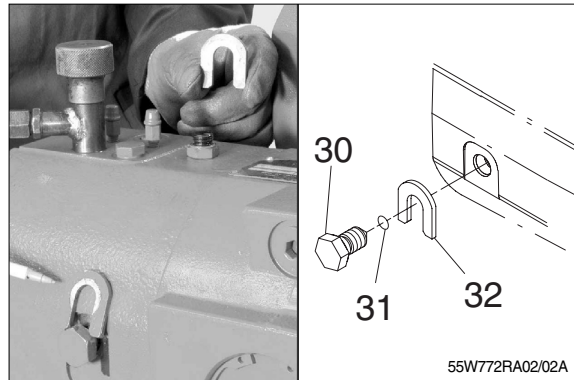

- (3) Insert block screws to end stroke and release pression.

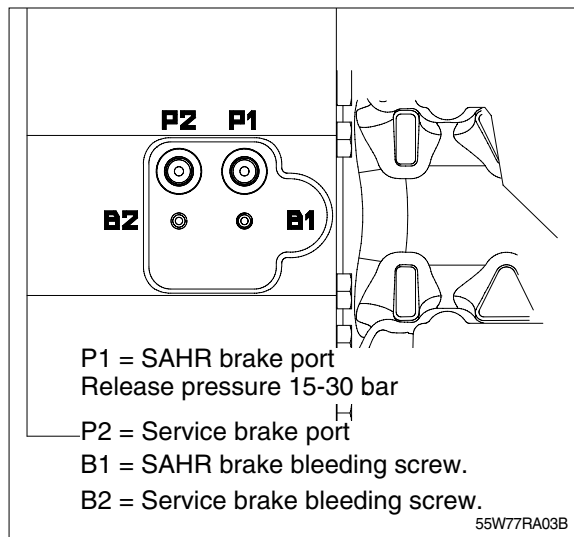
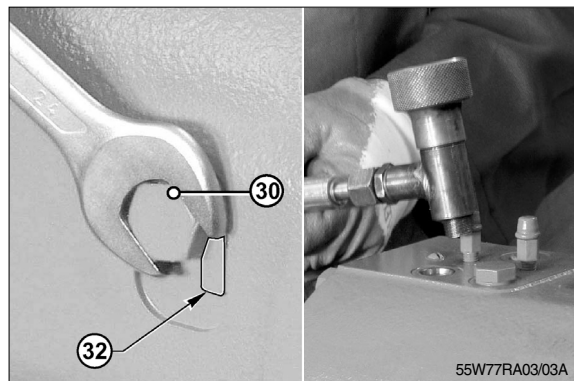

- (4) Remove the screws of the planetary gearbox cover on the brake side.
Remove the planetary gearbox cover.

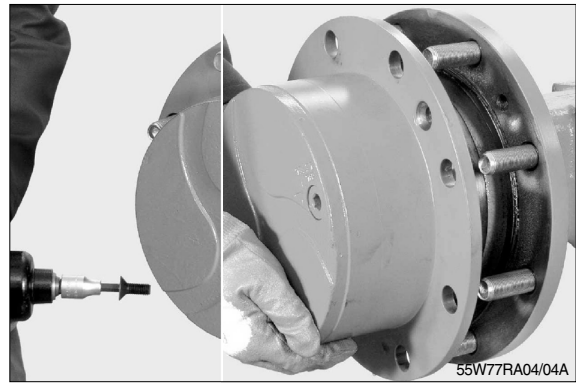

- (5) Remove the axle half shaft.

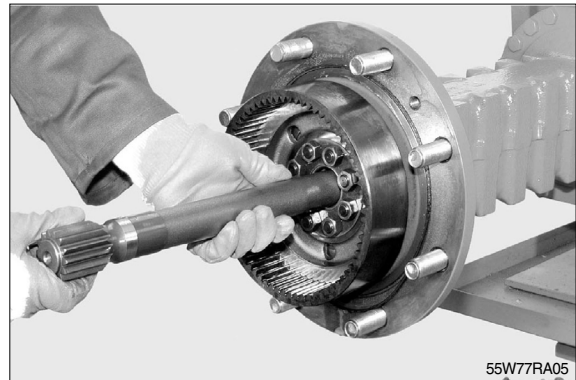

- (6) Sling the arm to be removed and connect it to a hoist, remove screws.

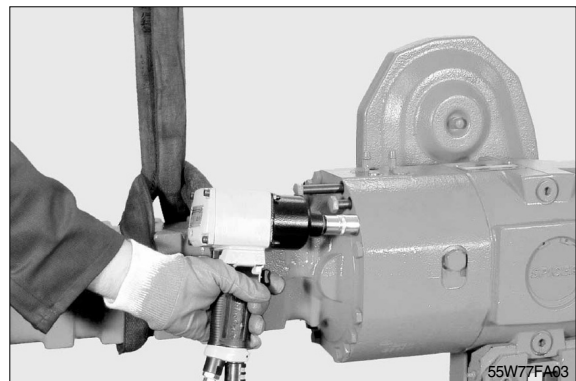

- (7) Take off the arm and lay it down vertically.

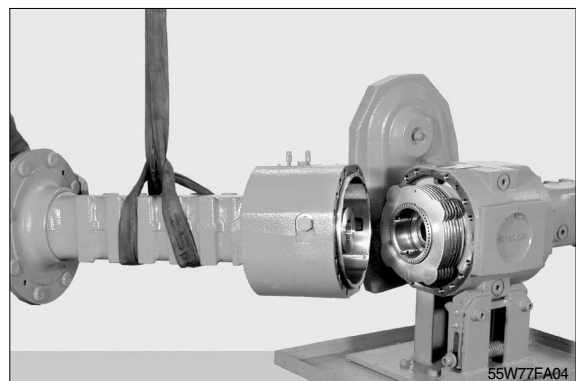

- (8) In order to keep the disc springs of the negative brake pre-loaded, screw down the screws with washers to the end stop.



- (9) Remove the negative brake locking screws(30).
Always exchange the O-ring(31).

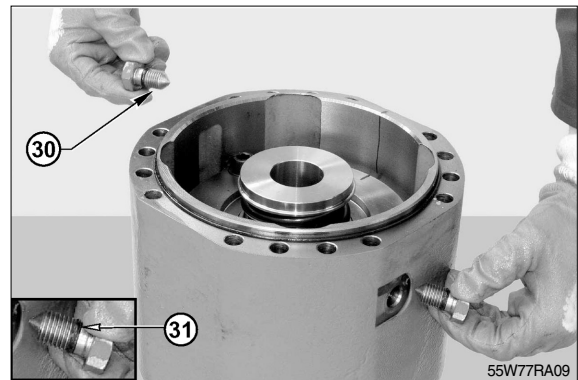

- (10) Loosen the before installed provisional screws in the same sequence and same measure.



- (11) Insert the screws of the puller(M12) into the tapholes of the negative brake and remove the pistons of the brake.

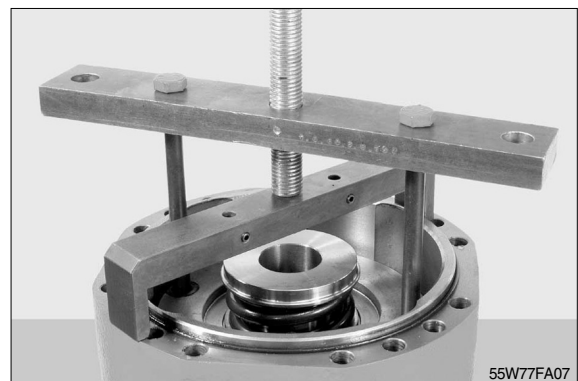

(12) Pull out brake piston assembly module.



(13) Check locking screw(33) of the brake piston module.

※ Attention

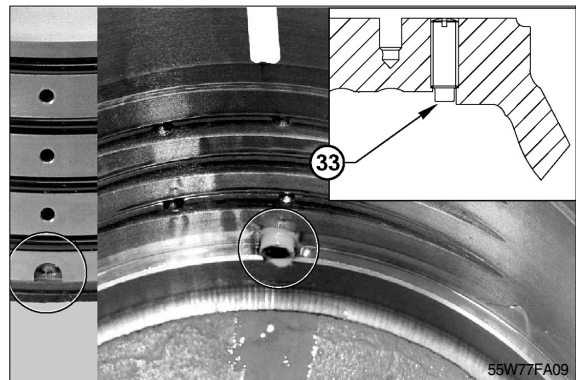

(14) Remove intermediate disc(2).

※ Sign the assembly position.



(15) Applying pressure to the first hole, remove the service brake piston(7).



(16) Applying pressure to the second hole, remove the hydraulic block piston(12).



(17) Applying gressure to the third hole, remove the three bolts(24).



(18) Turn upside down the brake module and with a pin driver remove the locking pin of the slotted nut.



(19) Sign the position of the slotted nut.

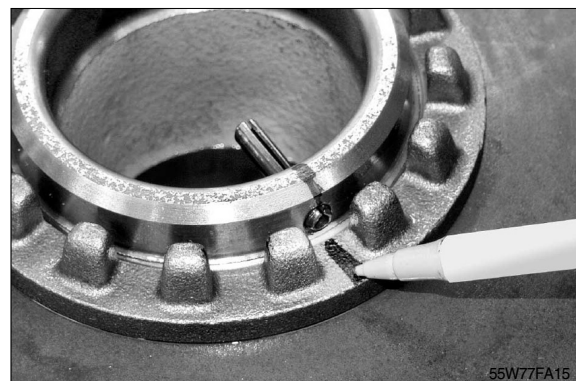

(20) Unscrew the slotted nut(26).

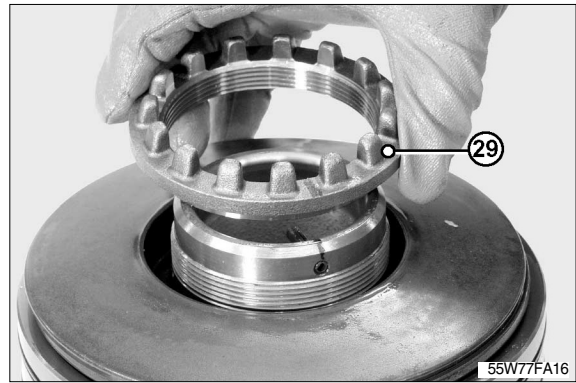

(21) Remove the disc springs(28).

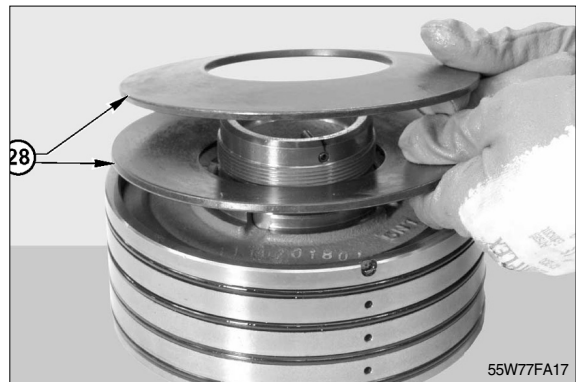

(22) Applying pressure, remove the piston(27) of the negative brake.



(23) Check the position of the anti-extrusion(8) (10)(14)(5) and O-rings(9)(10)(13)(6).

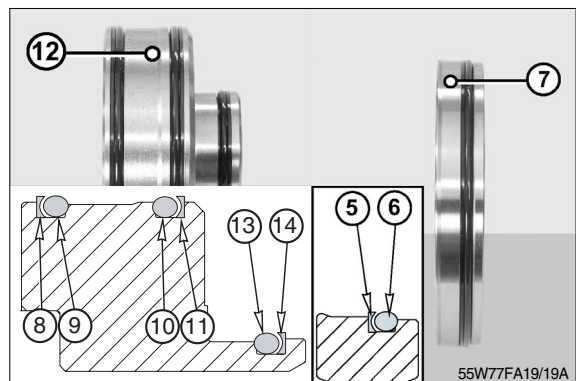

(24) Check the position of the O-rings(25)(26).

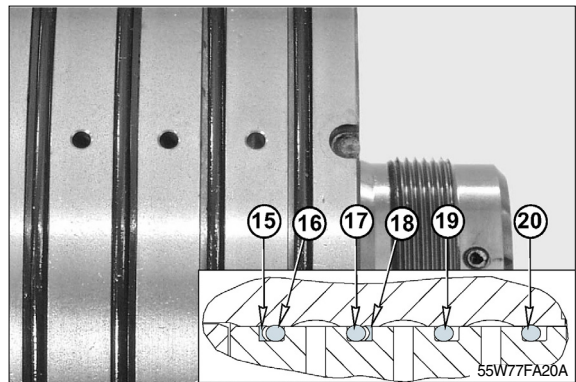
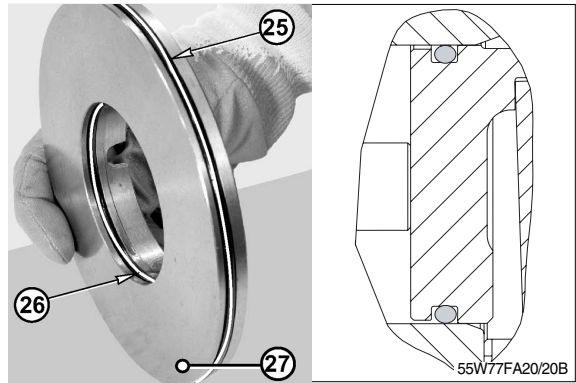

(25) Remove the snap ring(4) from the intermediate disc(2).

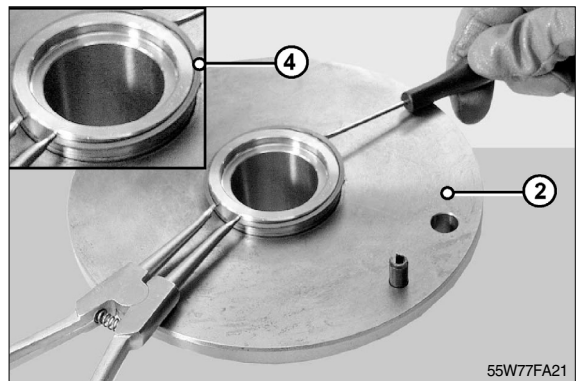

(26) Remove coupling(40) and washers(45).
※ Build a stack of washers and check the measure.

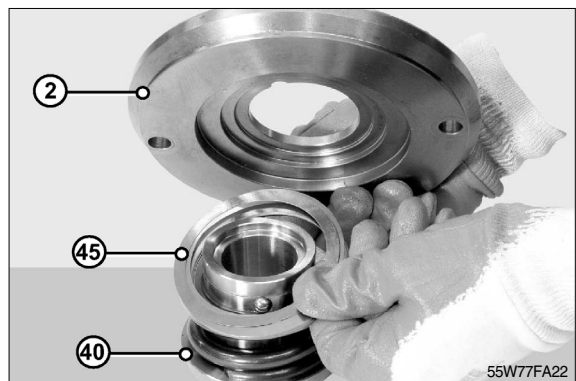

(27) Using a puller, preload the spring(42).



(28) Remove the snap ring(44).
※ Spring preloaded.



(29) Remove the fixing ball(41).

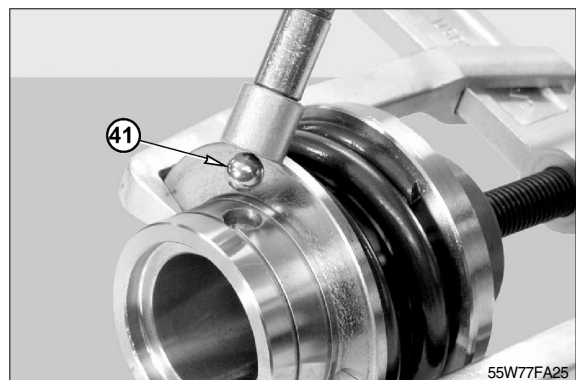

(30) Remove the spring(42) and washer(43).

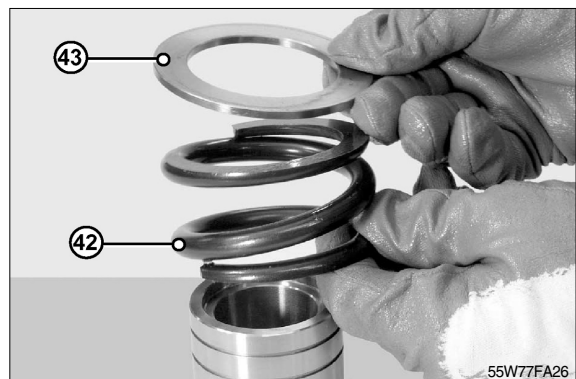

(31) Remove the snap ring of the brake stack.

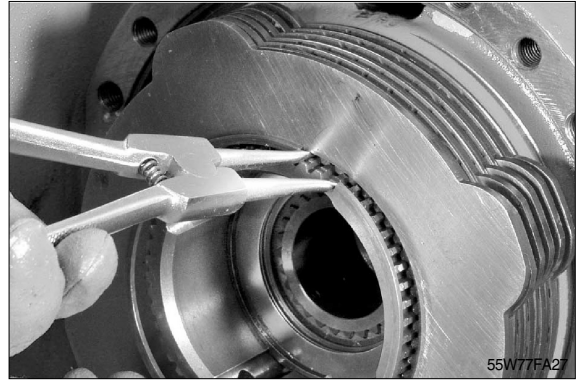

(32) Remove the brake discs one after the other(39)(38).

※ If they are not to be substituted, do not mix up the sequence.

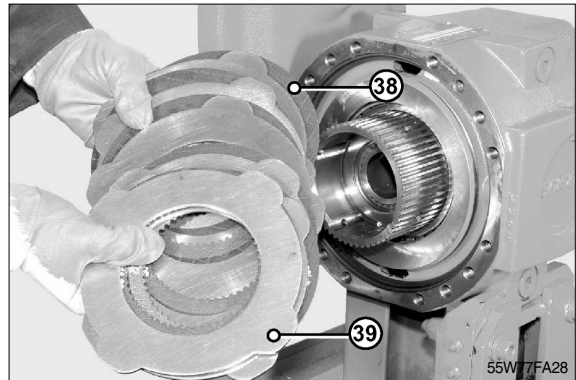

2) Assembly

- (1) Insert spring(43) and washer(42) onto the hydraulic block coupling.

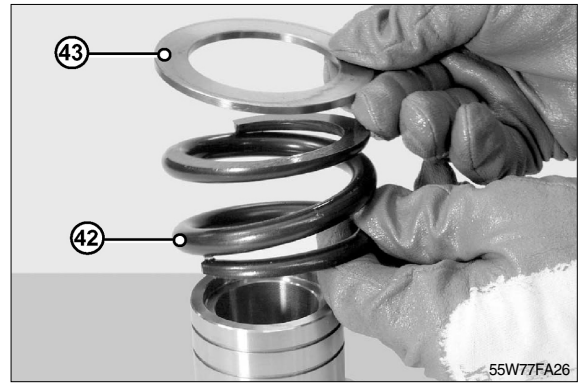

- (2) Preload the spring(42) by using a puller acting on the washer(43). Insert the snap ring(44) and the fixing ball(41).

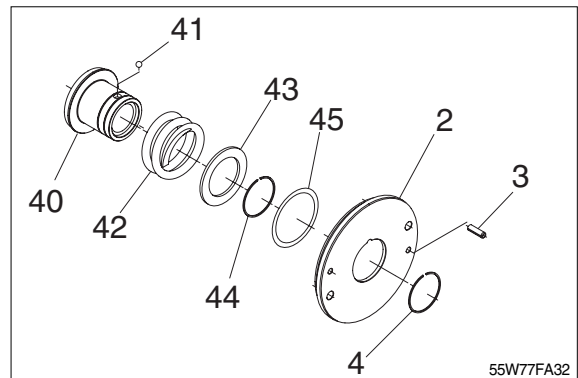
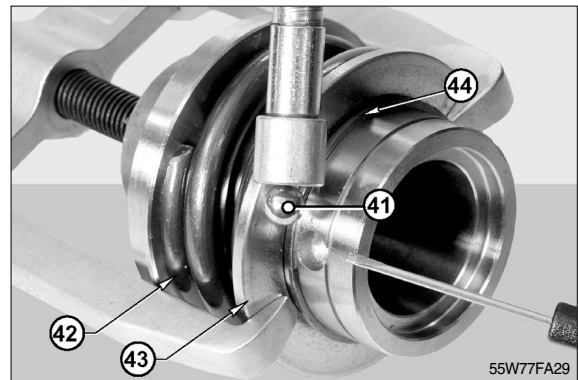

- (3) Shift the cut of the snap ring(15) according to the ball(41).



- (4) Complete the O-rings and anti-extrusion rings on all pistons.
※ The O-rings always have to be assembled from the pressure facing side.

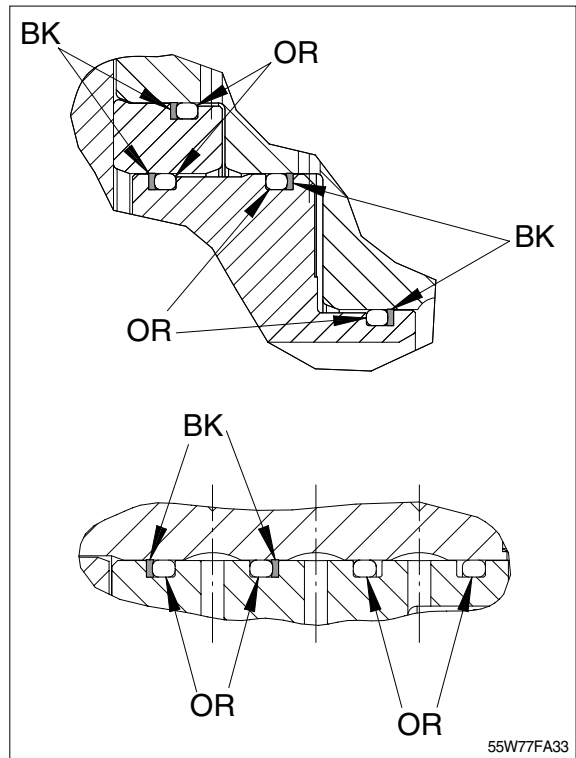
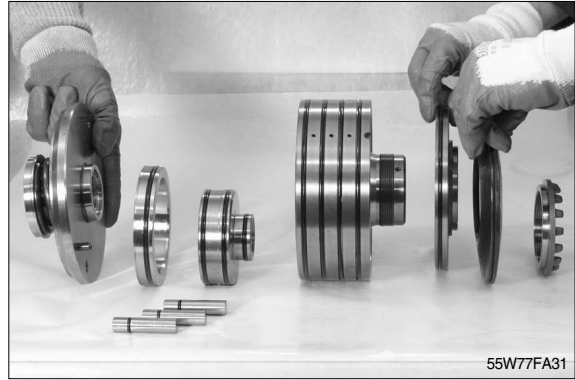

- (5) Insert the bolts(24).

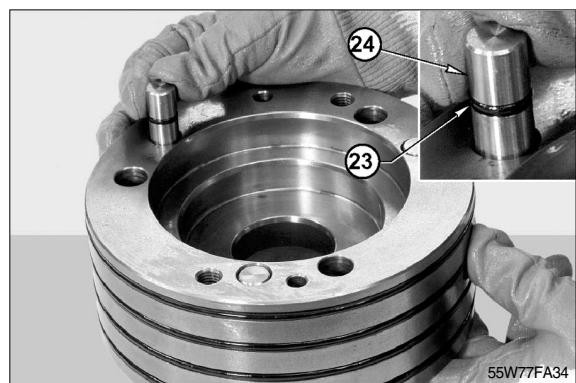

(6) Insert the hydraulic block piston(12).

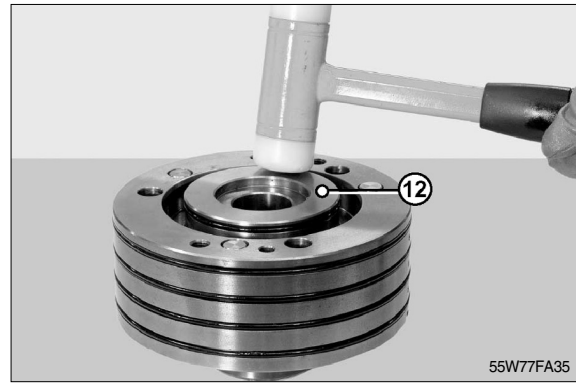

(7) Insert the service brake piston(7) hammering alternately with a plastic hammer.



(8) Insert the intermediate disc(2) observing the previously signed position.



(9) Turn upside down and insert the negative brake piston(27).



(10) Screw up the slotted nut(29) for about 5 turns.

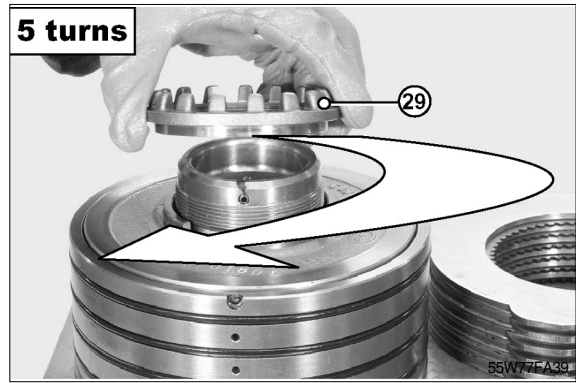

(11) Find out the level of the brake discs "D".
E.g. D = 44.7mm
Add to D the value G = brake clearance
(e.g. 1.4mm).
 $D + G = 44.7 + 1.4 = 46.1$

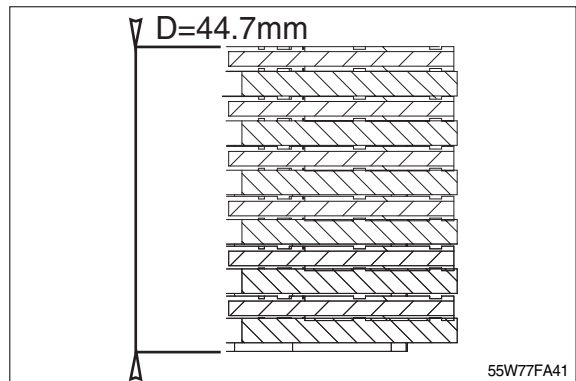
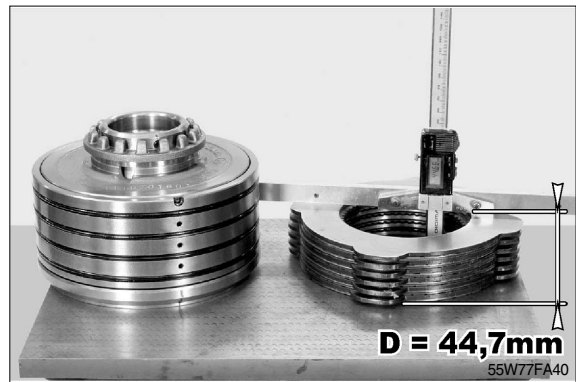

(12) Determin the level "A" between external plane and the brake plate by the adjustment of the slotted nut.

※ To define the level A adjust the slotted nut always to the smaller value by driving to the closer notch.

$$A = 141 - (D+G) = 141 - 46.1 = 94.9\text{mm}$$

X = constant value 141mm

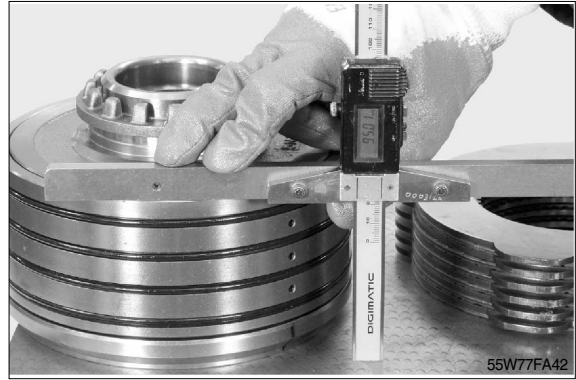

(13) To determine the level A the slotted nut has to be operated without spring mounted.

※ Attention!



(14) Before removing the slotted nut in order to insert the springs, note down the distance Z from the plane to the tooth near the pin.

※ Sign!

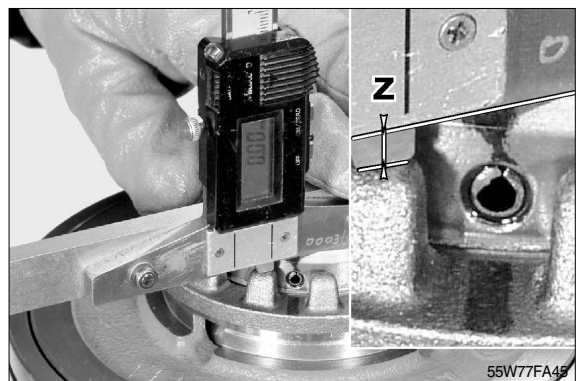

(15) Turn upside down and fit on the intermediate disc(2).

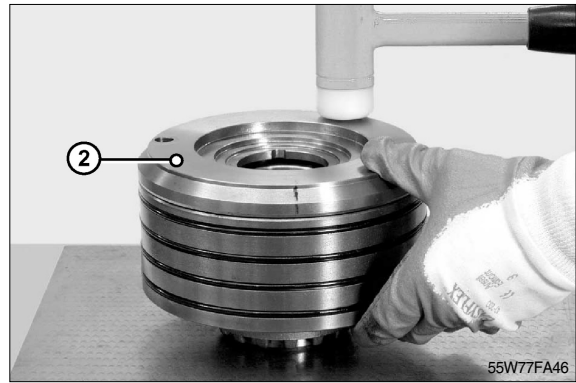

(16) Select a pack of washers(20) of 1.5mm
 $S_4 = 1.5\text{mm const.}$



(17) Insert and bring into position washers(45) and coupling(40) into the brake module (22).

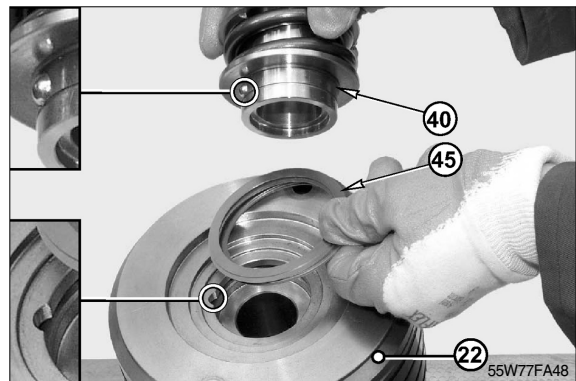

(18) With the positioned pack determine the distance L between coupling and brake disc surface.
E.g. $L = 37.5\text{mm}$

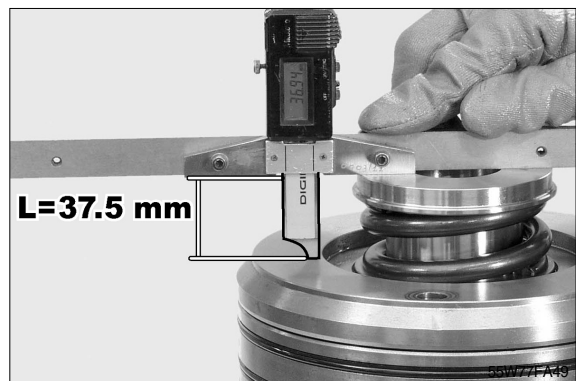

(19) Insert the brake discs(38) in the right sequence.

- ※ The first brake disc to be inserted must be of friction material.

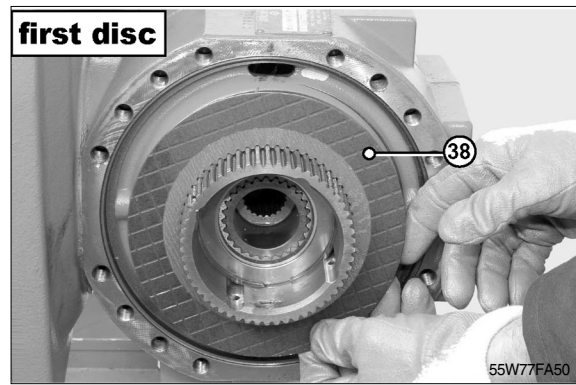

(20) Insert the brake discs(39) in the right sequence.

- ※ The last brake disc to be inserted must be of metal material.

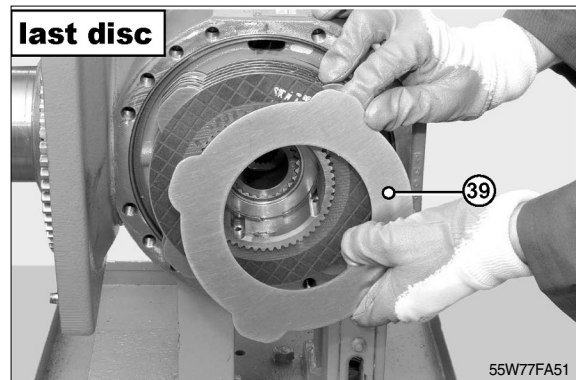

(21) Zero the depth gage from the plane of the splined coupling to the surface of the brake discs.

- ※ Press the brake disc pack before zeroing, execute the measurement in some points and take an average.

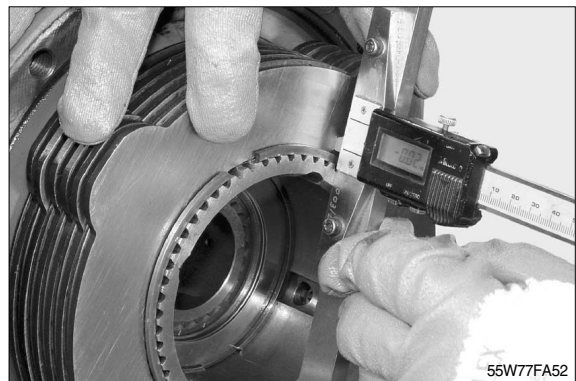

(22) Check of the clearance "R" between coupling and thrust bearing. Find out the distance "M" between the brake discs surface and thrust bearing.

※ M=36.4mm

Brake discs clearance G=1.4

$R=(M+G)-L=(34.6+1.4)-37.5=0.3\text{mm}$

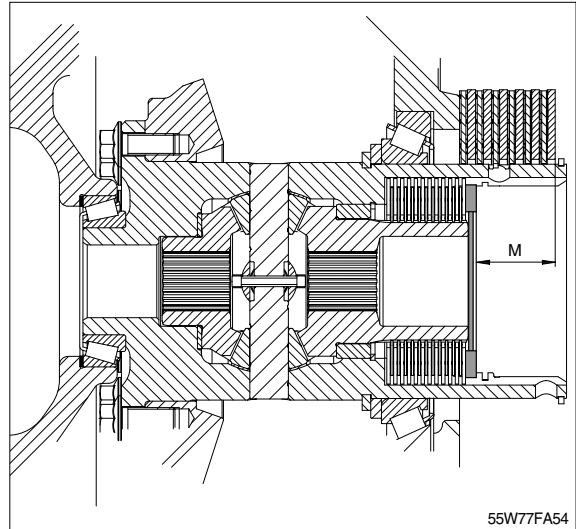
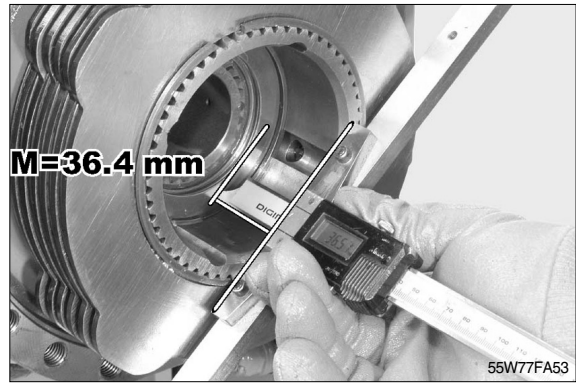

M=Needle bearing distance

(23) Correction of the shims S4 depending on the calculation of the value "R"

※ The value of "R" has always to result in 0.1mm in case it is not so, the shims S4 (45) under the coupling(40) have to be modified.

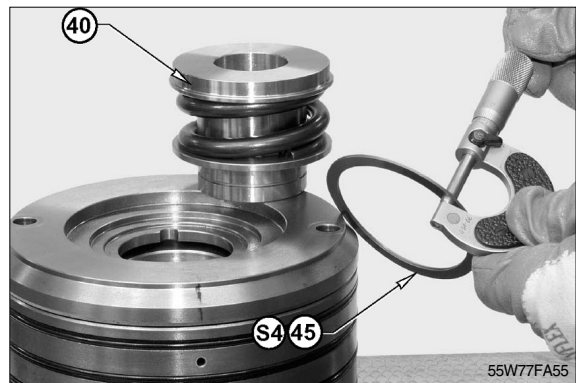

(24) Depending on the calculation assemble the exact shims to arrive at R=0.1mm.

Assemble all with safety ring.

Where 1.5 const. Shims S4 z.B.: $S4=1.5+(0.3-0.1)=1.5+0.2=1.7\text{mm}$

0.3mm = R calculated clearance

0.1mm = R wanted clearance



(25) Insert the complete intermediate disc(2).



(26) Turn upside down and unscrew the slotted nut(29).



(27) Insert the disc springs in the right position (28).

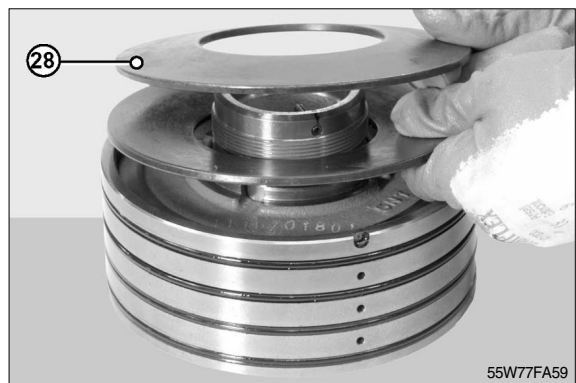

(28) Insert at the bottom the piston of the negative brake(27) and screw up the slotted nut(29).

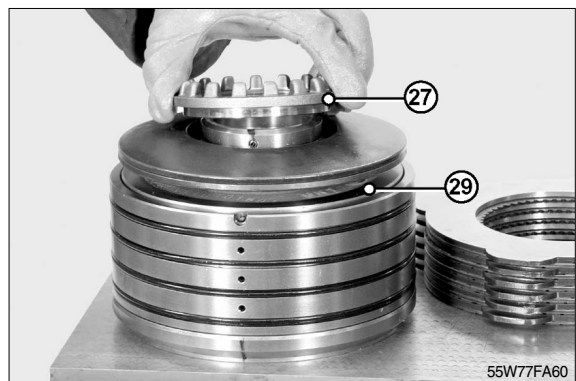

(29) Screw down the slotted nut to the earlier determined position.

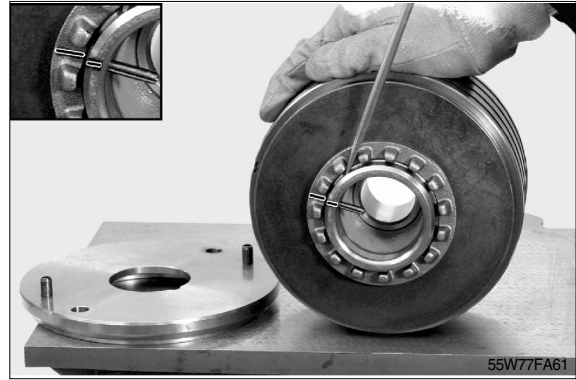

(30) Check the earlier measured distance Z from the plane to the tooth next to the pin.

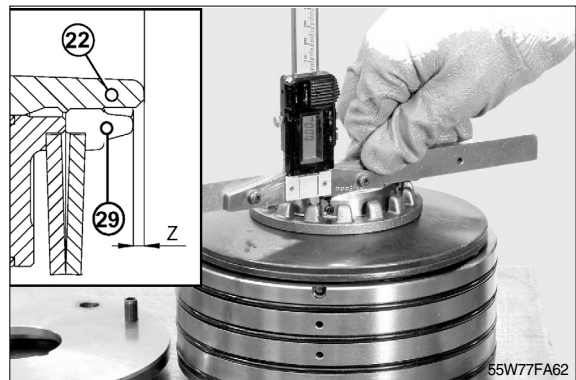

(31) Put the pin in locking(21) position.

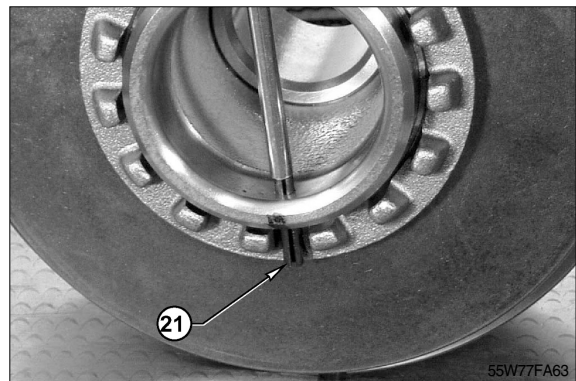

(32) Insert two screws of M12 to fix the break arm.



(33) Position the groove of the brake module in line with the lock screw in the arm.

※ Attention!



(34) Check locking screw(33) of the brake piston module.

※ Attention!

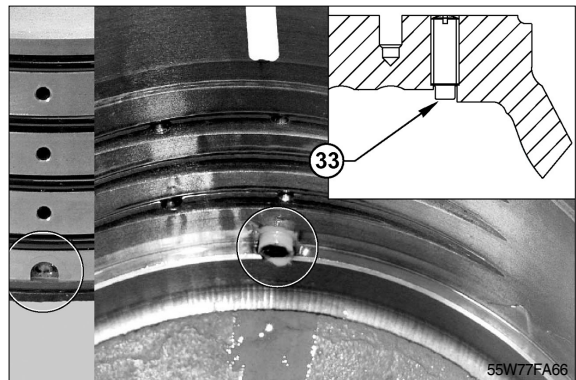

(35) Insert the brake modul facing the input holes to the top.



(36) Insert the piston to the end stop by alternating light strokes and remove the screws.



(37) Temporary insrt screws M12 × 45



(38) Alternately tighten with a torque wrench setting of max. 45Nm(33.2lbf · ft)

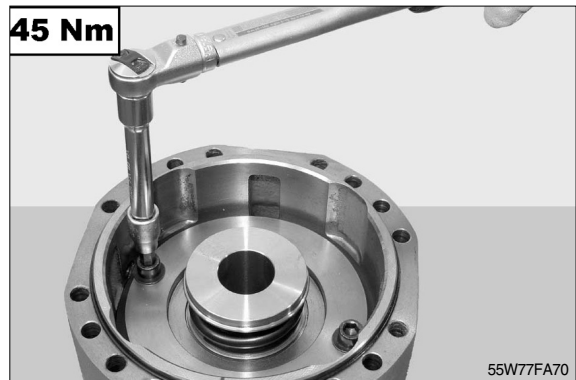

(39) Insert the negative brake unlocking screw(30) up to the end stop.

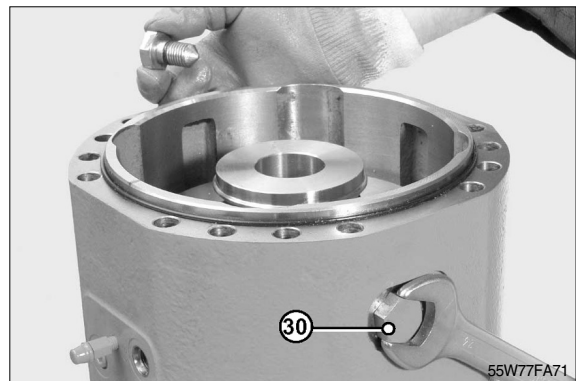

(40) Remove the two auxiliary screws.



(41) Exchange and lubricate the O-ring and insert the arm to the box.

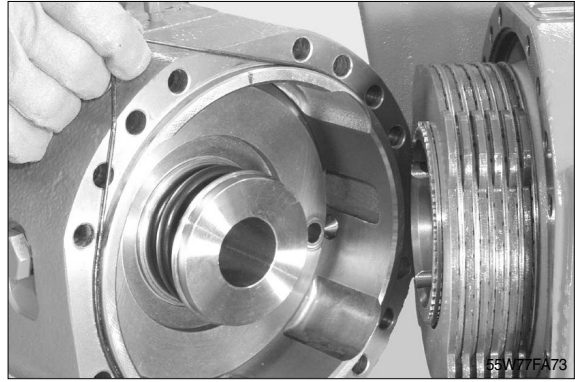

(42) Insert the screws and tighten them alternately.
· Torque : 128Nm(94.4lbf · ft)

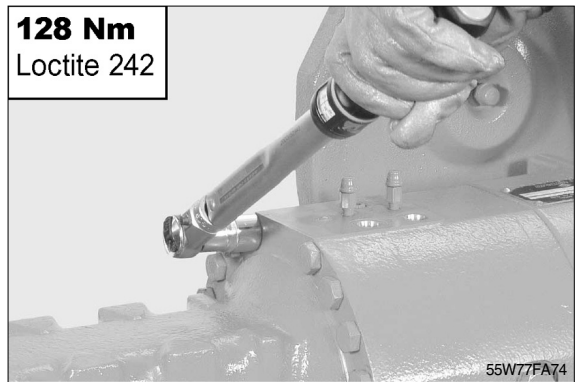

(43) Introduce a pressure of max. 25bar and loosen the unlocking screws.

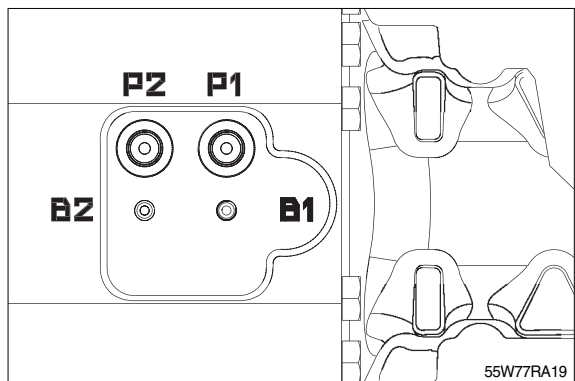
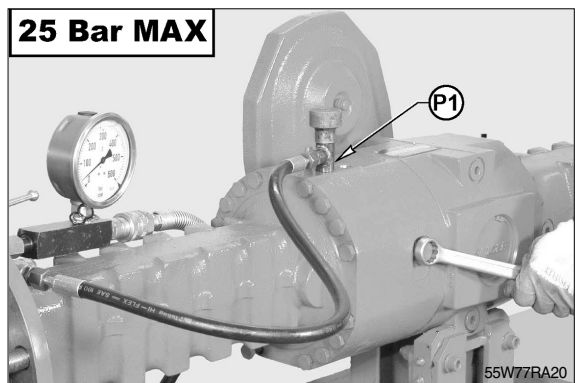

(44) Insert the two "U"-shaped shims and tighten the screws with a torque wrench setting of 95~115Nm(70~84.8lbf · ft)

※ The position of the negative brake is unlocked.

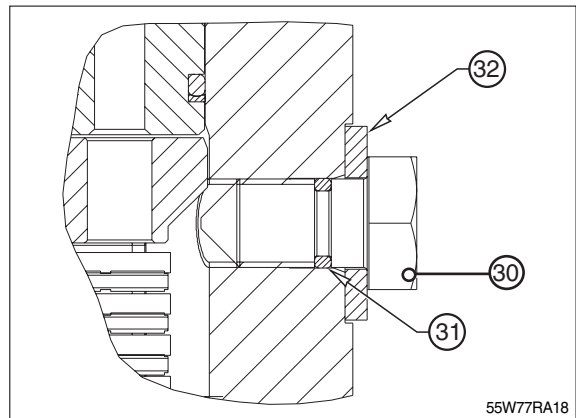
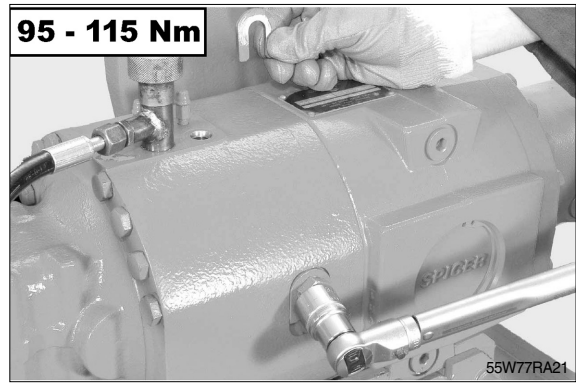

4. DIFFERENTIAL : NORMAL PRELOADED DIFFERENTIAL

1) Disassembly

- (1) Remove the brake side arm and the brake discs pack.

Sling the arm to be removed and connect it to a hoist, remove screws of the crown wheel side arm.

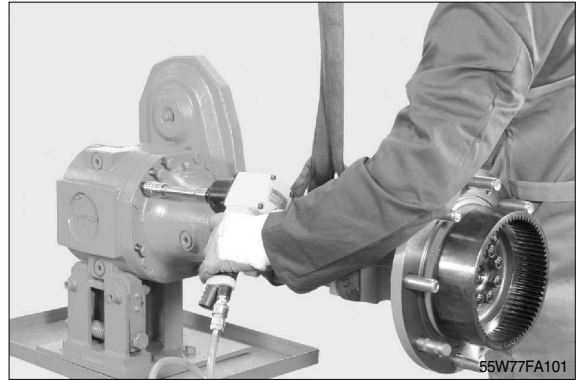

- (2) Remove the hydraulic block discs one after the other.

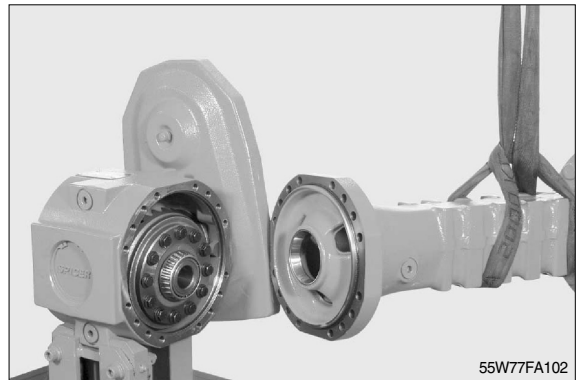

- (3) Position the differential gear sideways into the recess in order to be able to pull it out.

※ Attention!

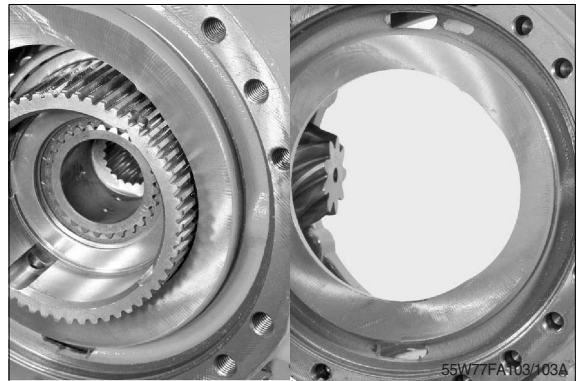

- (4) Pull out the differential.

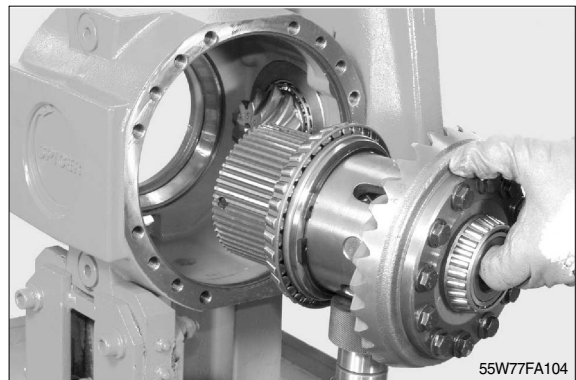

- (5) Remove the snap ring(22) that secures the thrust bearing.

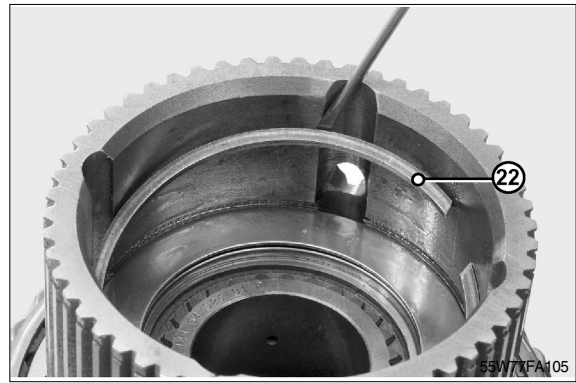

- (6) Remove the snap ring(22) and thrust bearing(23).

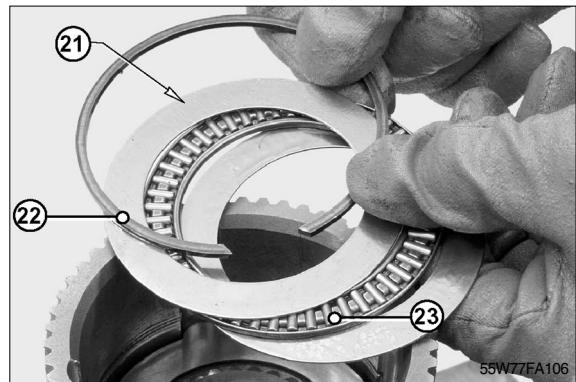

- (7) Remove the hydraulic block discs(20)(24) one after the other.

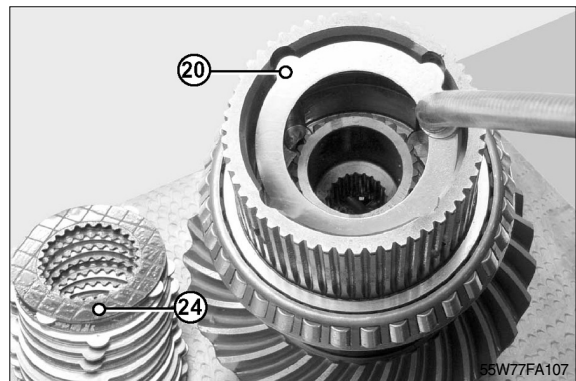

- (8) Remove the snap ring(19) that secures the planetary gear.

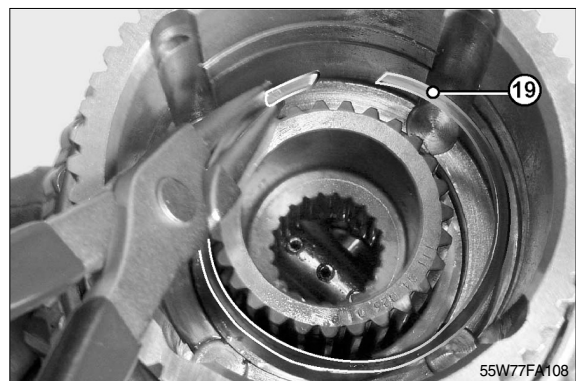

(9) Remove the brake side planetary gear.

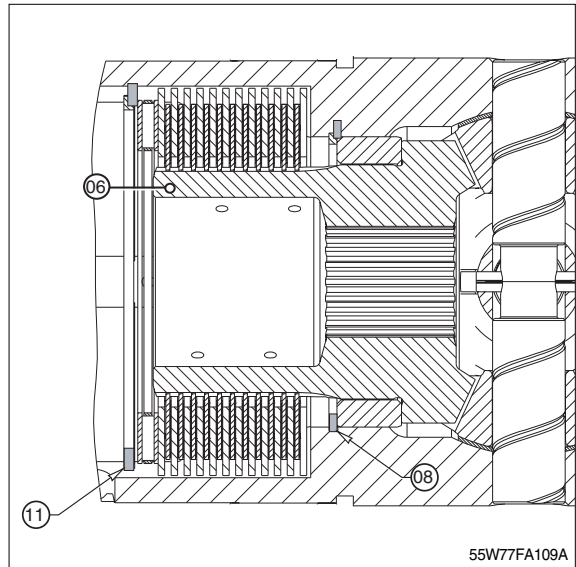
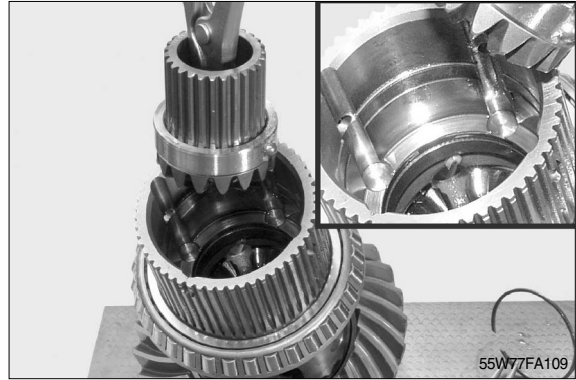

(10) Remove the snap ring(33) out of it's seat by moving it sideways.

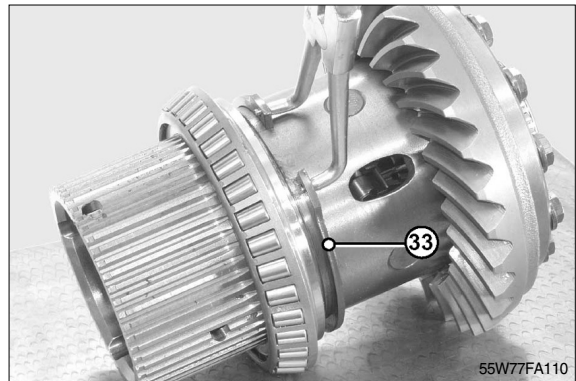

(11) Using a puller, extract the bearing(35) and the washer(34).

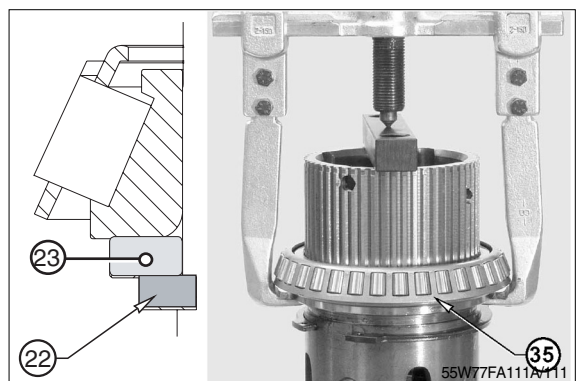

(12) Remove completely bearing(35), washer (34) and snap ring(33).

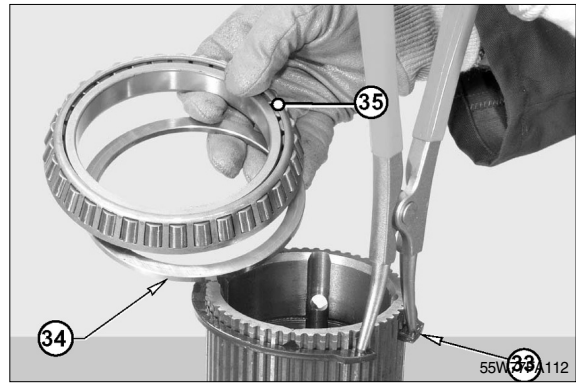

(13) Remove fixing screws(32) of the crown wheel(31); exchange each time when removed.



(14) Extract the crown wheel(4).

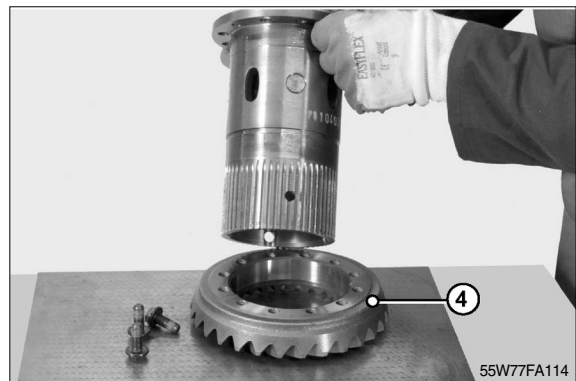

(15) Remove the tapered roller bearing(2) of the crown wheel side, using two levers.

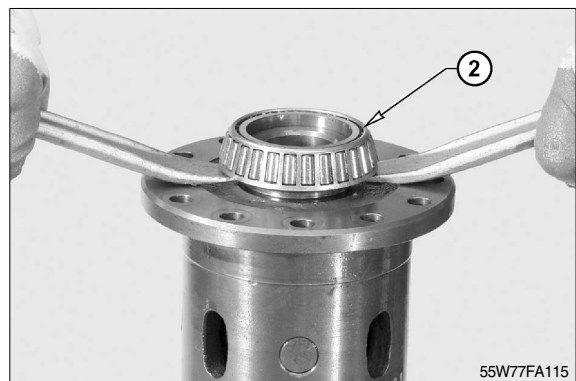

(16) Remove the three spider blocking pins(10) (13)(26)) by using a pin driver.

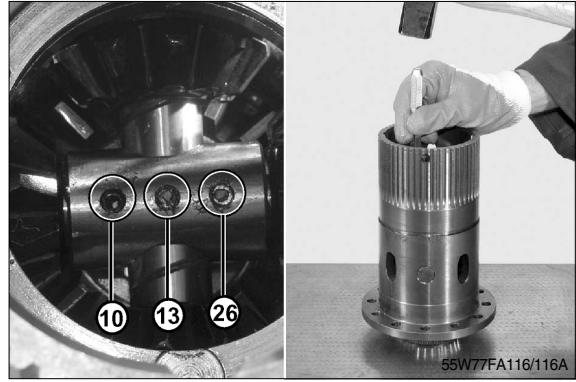

(17) Move the two opposite mounted short bolts(9)(28) to the outside of the box using the same pin driver.

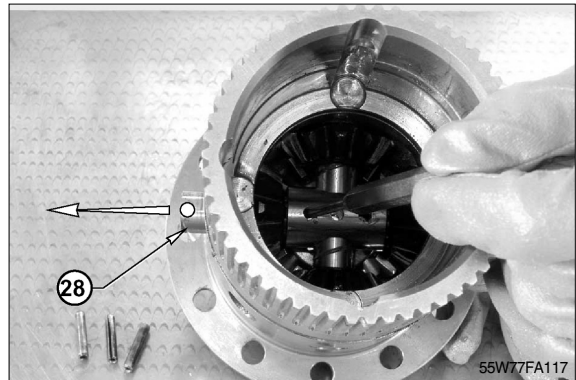

(18) Drive out the long bolt(14) and pull out the spider(16) from the centre.

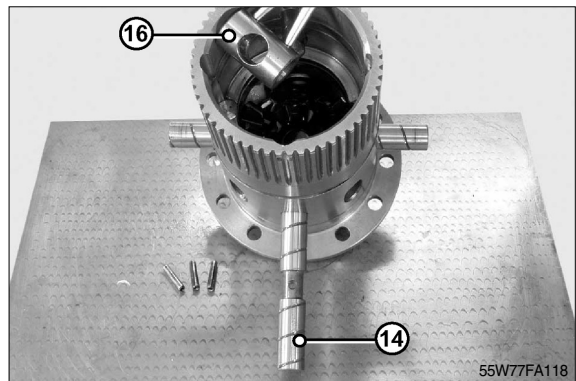

(19) Remove the two half bolts(9)(28), spherical washers(8)(28) and satellite wheels(27)(7).

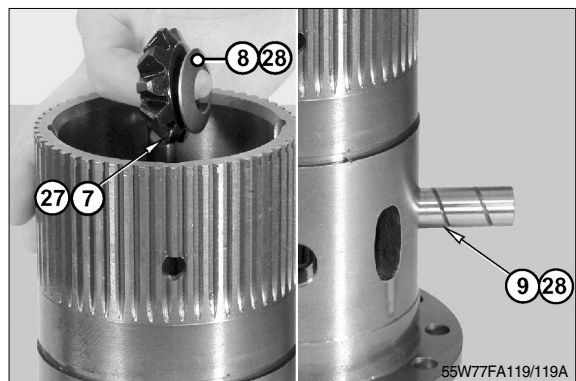

(20) Remove long bolt(14), spherical washers (12)(29) and satellite wheels(30)(11).

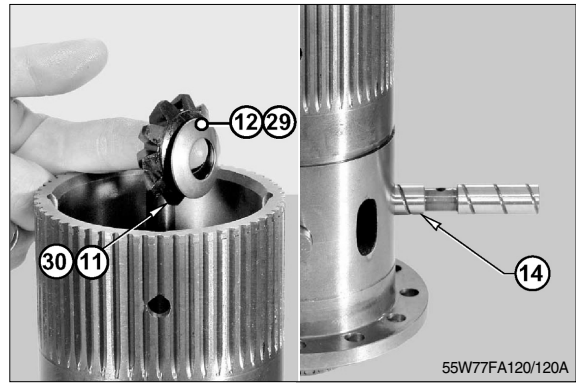

(21) Remove the planetary gear(6).

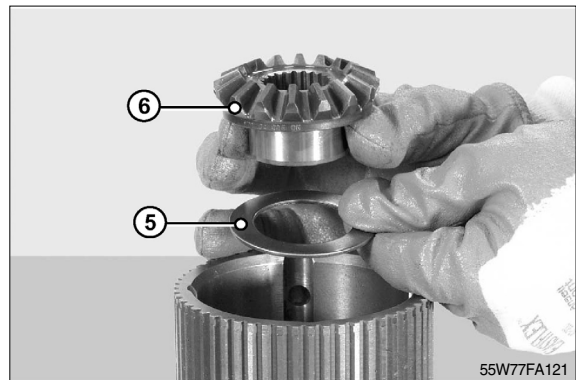

(22) Arrangement of the differential.

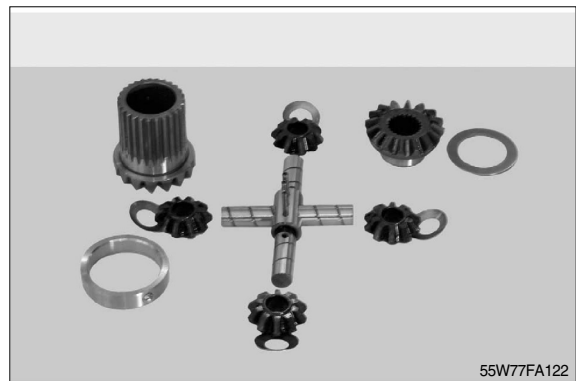

2) Assembly

(1) Differential module assembled



(2) Lubricate and insert washer and planetary wheel.



(3) Insert the two half bolts(28)(9), spherical washers(8)(28) and satellite wheels(7) (27).

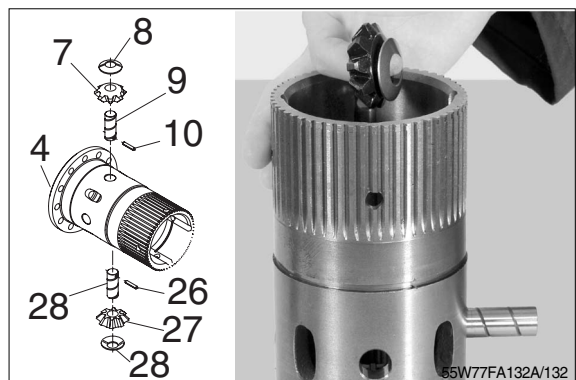

- (4) Partially insert the long bolt(14), satellite wheels(11)(30) and spherical washers(29) (12).

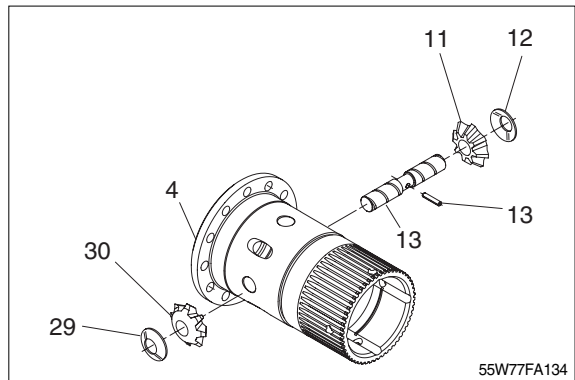
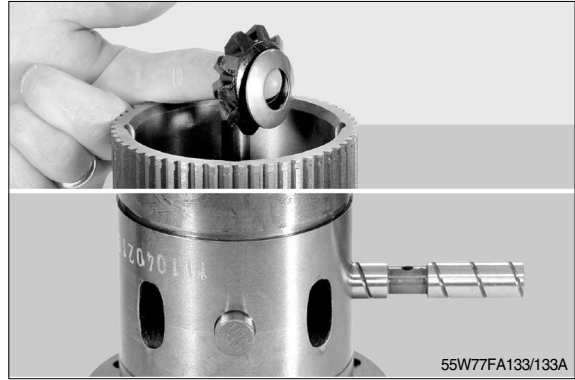

- (5) Insert spider(16) and completely insert the long bolt(14).



- (6) Insert completely the half bolts(9)(28).

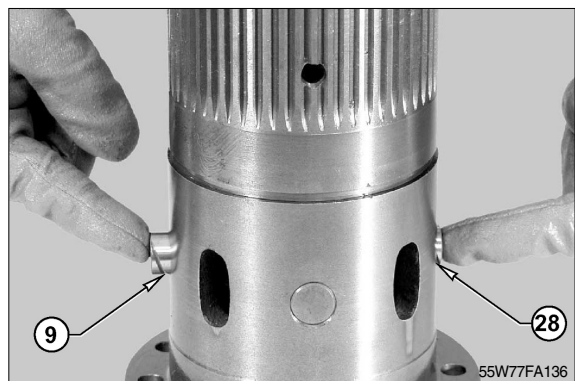

(7) Centre the pin holes and insert the 3 pins (10)(13)(26).

※ Check the free rotation of the satellite wheels on the bolts.

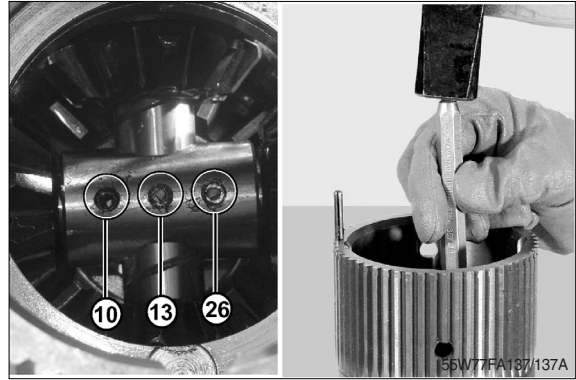

(8) Insert the planetary wheel together(17) with the centering sleeve(25).

※ The centering sleeve must have the fixing ball(18) assembled.

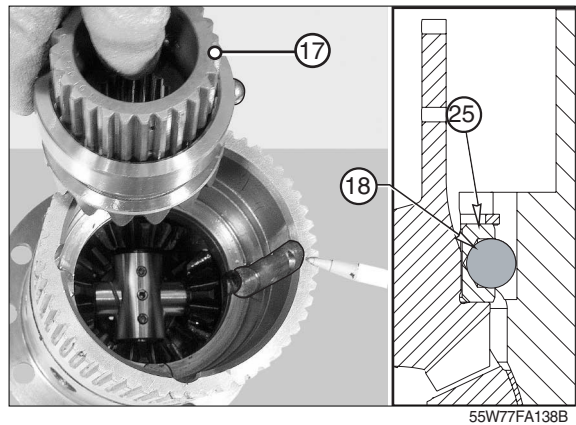

(9) Insert snap ring(22) of the planetary wheel.

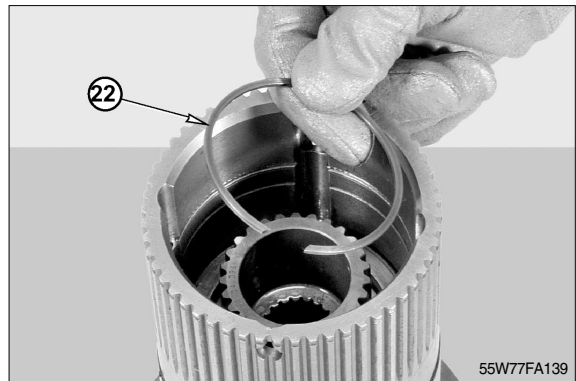

(10) Insert and substitute, if necessary, the discs(20)(24) of the differential lock.

※ First and fast disc have to be of steel.

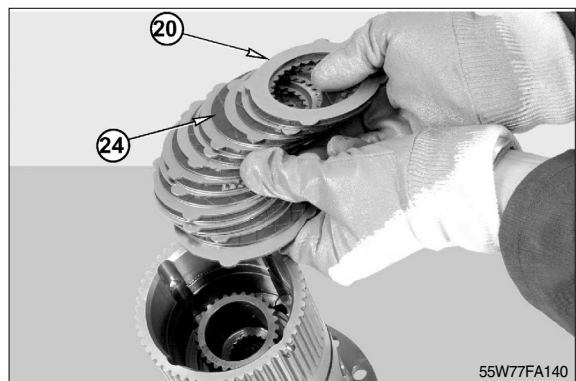

(11) Insert thrust bearing(23) and snap ring (22).

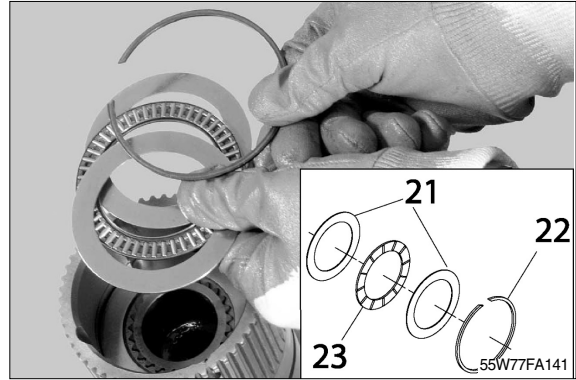

(12) Insert crown wheel(31).

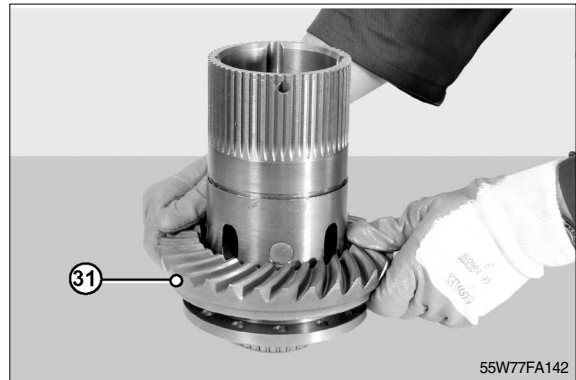

(13) Insert the screws(32).

Tighten screws with a torque wrench setting of 78~86N · m(57.5~63lbf · ft).

※ Always use new screws to fix the crown wheel. In case the screws are not thread locking pretreated, use Loctite 270.



(14) Assemble the bearing(2).

※ Heat the bearing to 100° C before assembling.

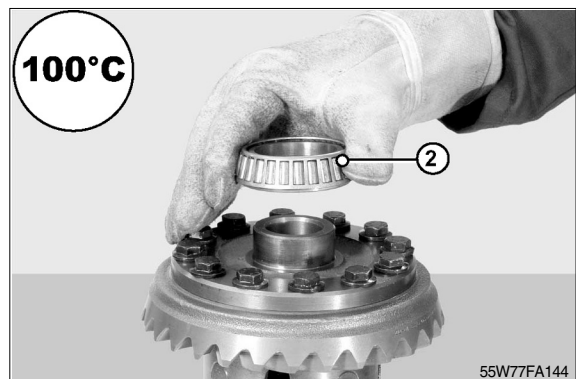

(15) Assemble the snap ring(33) in it's seat.



(16) Assemble shim(34) and bearing(35).

※ Heat the bearing as well as the shim to 100° C before assembling.



5. BEVEL PINION

1) Disassembly

(1) Make positional marks across nut(1) and pinion(11) tang;

If disassembly is awkward, heat the check nut(1) of the flange(2) at 80° C.

※ Heating is meant to unloose the setting of loctite on the nut(1).

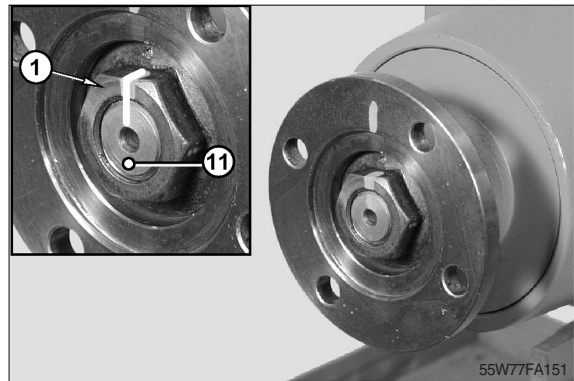

(2) Position tool T5, so as to avoid pinion rotation. Unloose and remove the nut(1); also remove the O-ring(6).

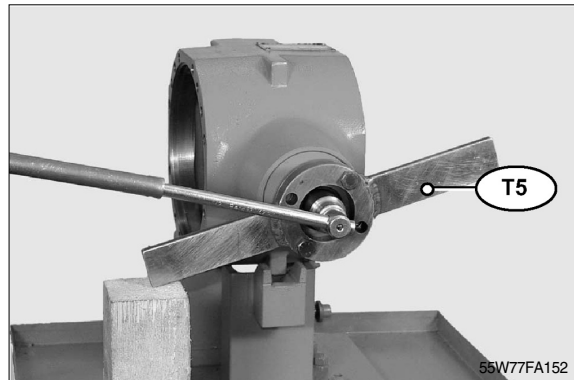

(3) Remove the flange(2) complete with guard(7) by means of a puller.

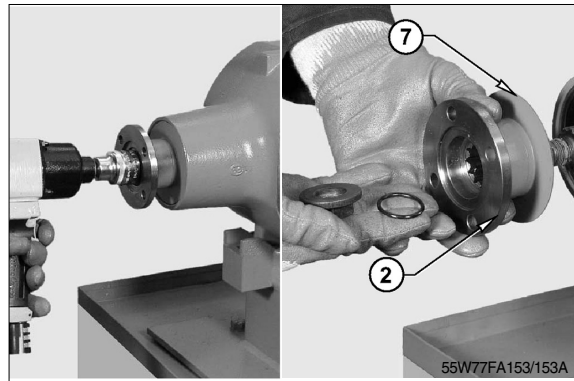

(4) Remove the sealing ring(3).

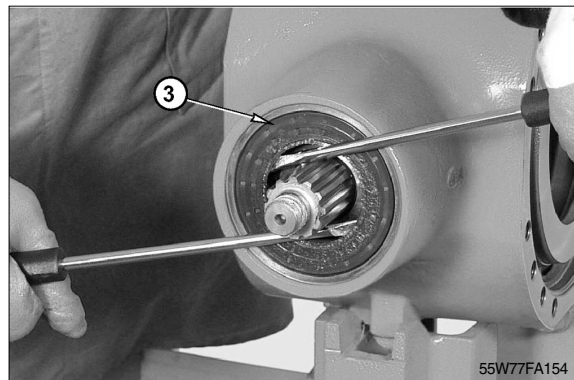

(5) Remove the sealing ring(3) and spacer (8A).

※ Sealing rings(3) must be replaced each time the unit is disassembled.

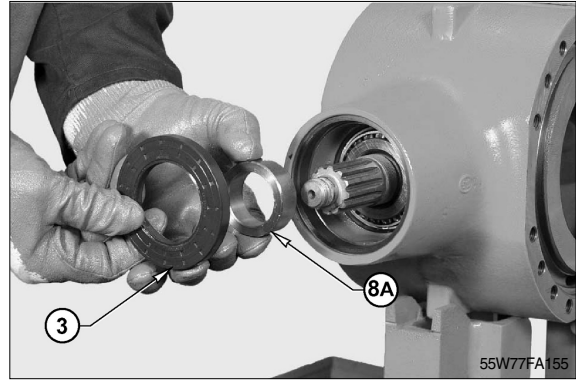

(6) Remove the pinion(11), shims and distance piece.

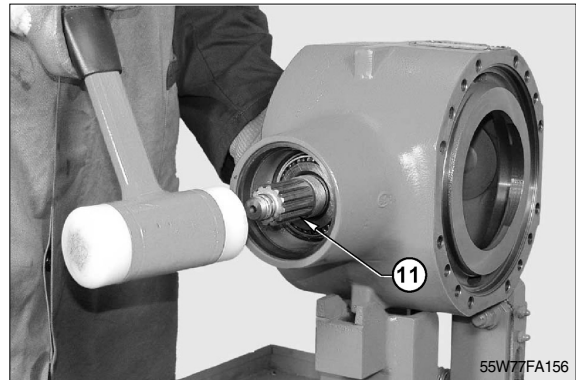

(7) Refer and keep to the positions marked during disassembly.

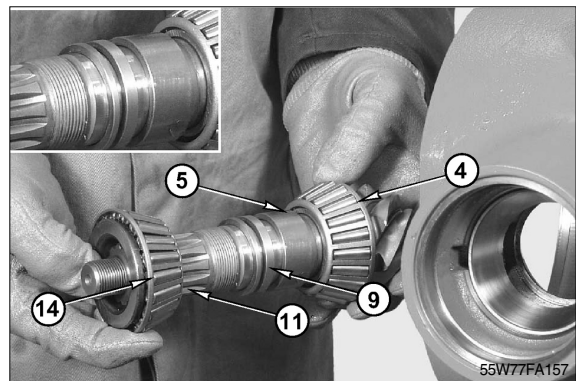

(8) Using a puller and a press, remove the inner bearing(4) from the pinion(11).

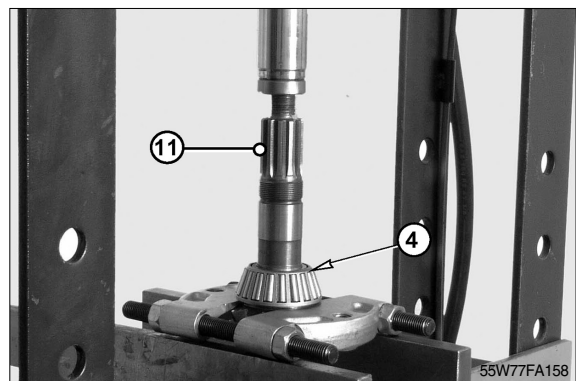

(9) Remove the thrust block of the external bearing(14).

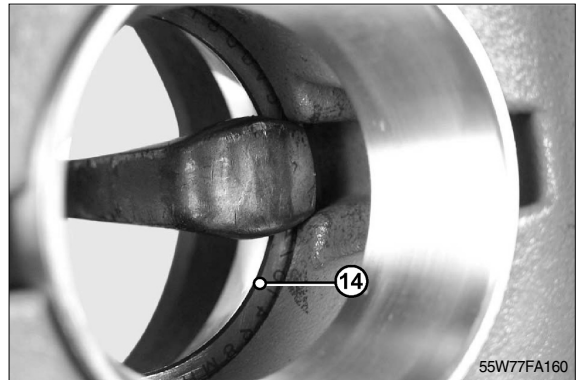

(10) Insert a drift in the appropriate holes.

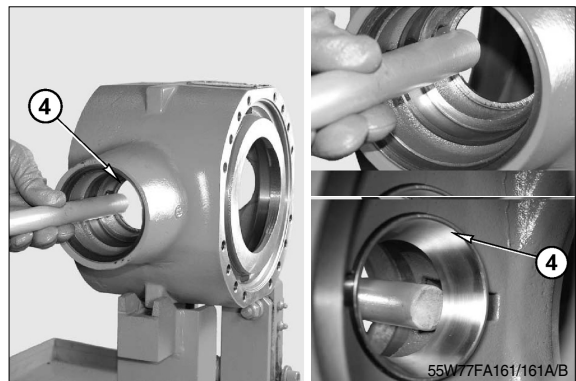

(11) Remove the thrust block of the internal bearing(4) as well as the shim washers (10)(S).



(12) Remove the snap ring(15).

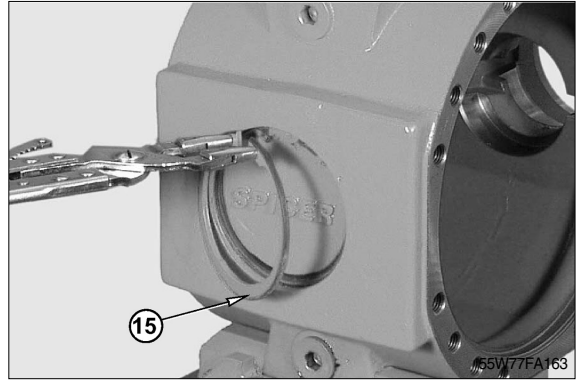

(13) Remove the cap(14).



2) Assembly

(1) Calculating pinion centre distance

Using a faceplate, reset a centesimal comparator "DG" on a calibrated block (Whose known thickness is 30mm).
Preload the comparator by about 3mm.

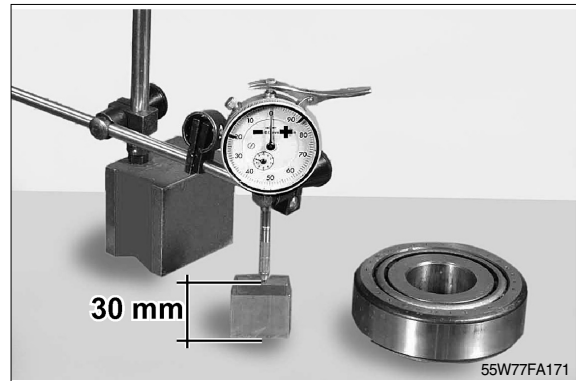

(2) Bring inner bearing(4), complete with thrust block, under comparator "DG".

※ Press the thrust block centrally and carry out several measurements by rotating the thrust block.

(Example : $30 - 0.55 = 29.45 = "D"$)

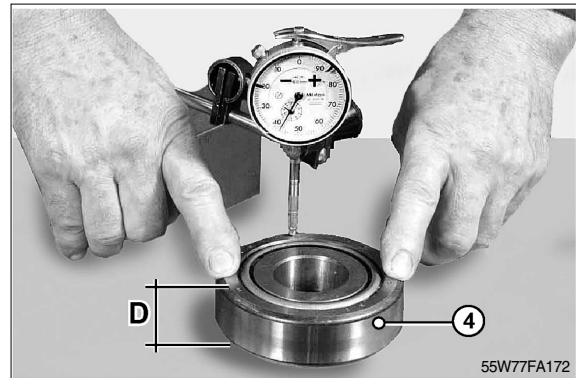

(3) Check nominal dimension "I" as marked on the pinion. Add up to or subtract from "I" the variation indicated as "Y" to obtain the actual centre distance "I".

(Example : $I = INT \pm Y = 98 - 0.1 = 97.9 \text{ mm}$)

※ C61=Match part number

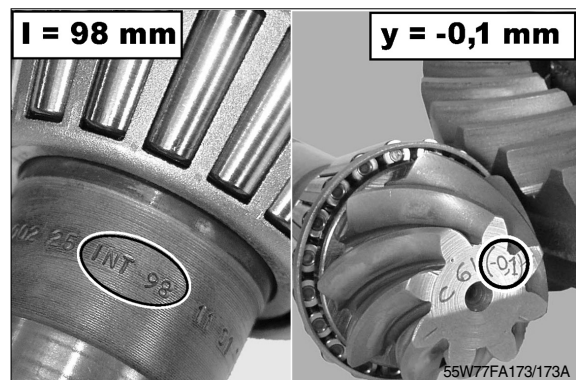

(4) C61 = bevel gear set matching number (-0.1) = Y variation from the theoretical I=98

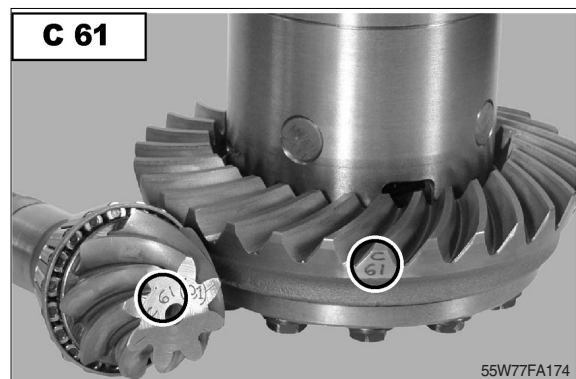

- (5) Calculate shims "S" for insertion under the thrust block of the inner bearing using the following formula:

$S = X - (I + D)$ where: X = fixed dimension

I = Actual pinion centre distance

D = Total bearing thickness;

(Example: $S = 128 - (97.9 + 29.45) = 0.65\text{mm}$)



- (6) Using special tool T8.
Partially insert the thrust block of the bearings(4) and shims(10).

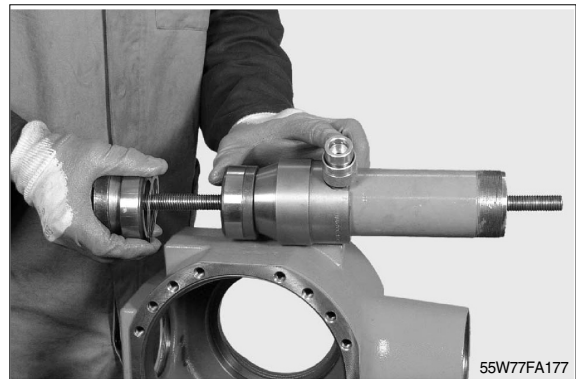
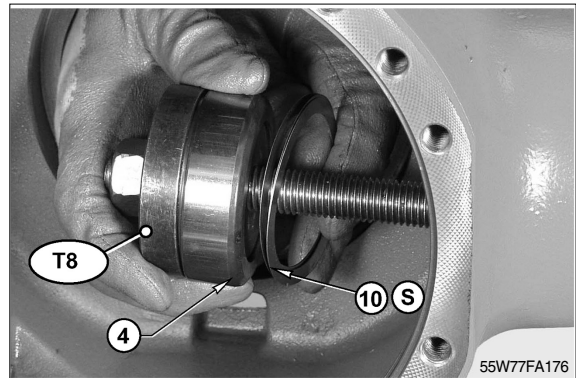

- (7) Connect the tension rod to the press and move the thrust block of bearings(4)(14) into the seats.

Disconnect the press and remove the tension rod.

- ※ Before starting the next stage, make sure that the thrust block has been completely inserted into its seat.

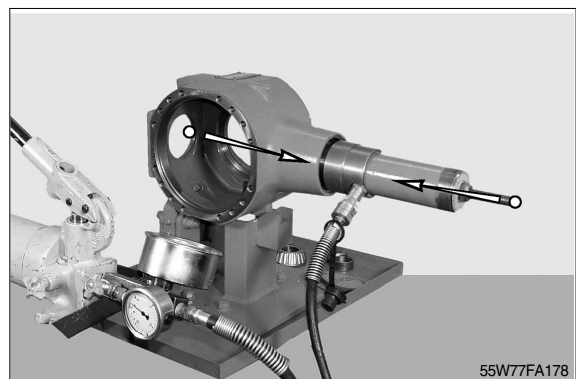

(8) Calculating pinion bearings rolling torque

Introduce tool T9 complete with bearings (4) and (14) into the main body(12); tighten by hand until a rolling torque is definitely obtained.

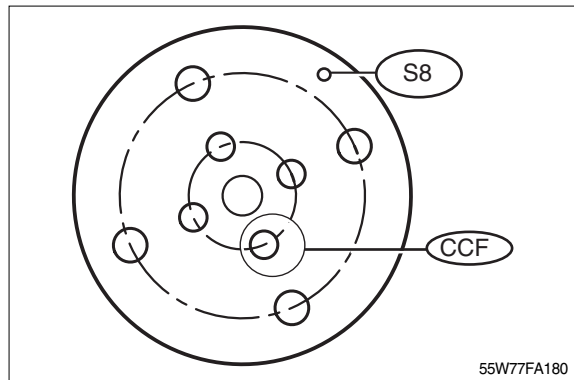
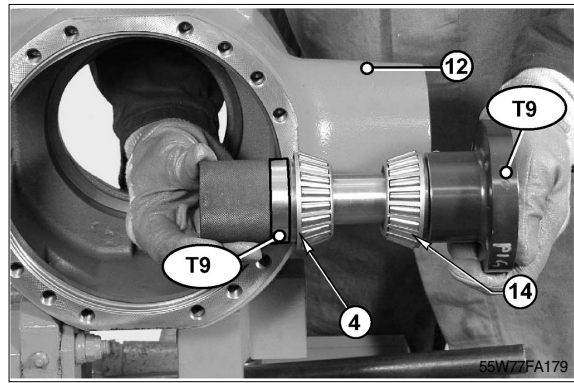

(9) Introduce the tracer of a depth comparator "DDG" into either side hole of tool T9. Reset the comparator with a preload of about 3mm.

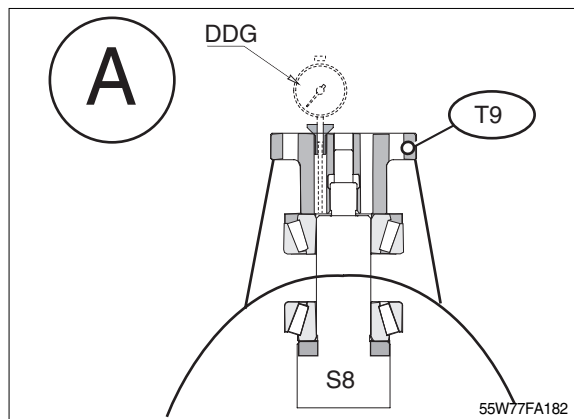
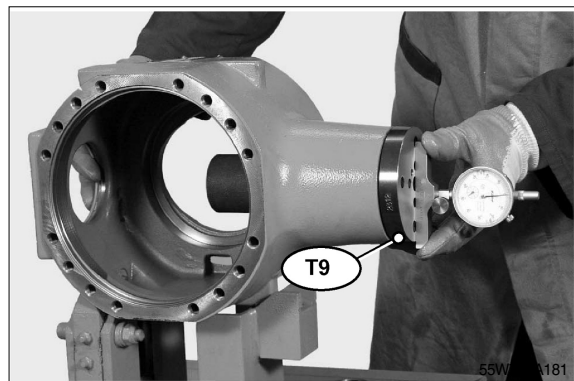

- (10) Remove the comparator and take out tool and bearing kits from the main body. Reinstall every part, also introducing a distance piece between bearings(4) and (14). Tighten the entire pack by hand.

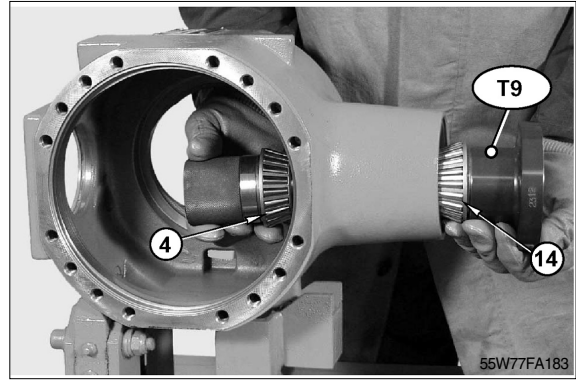

- (11) Assemble on top of the tool T9 and between the two bearings the shim(5) and the largest calibrated shim(9).



- (12) Measure the difference H using a dial gauge DDG
E.g. $H = A - B = 2.93\text{mm}$

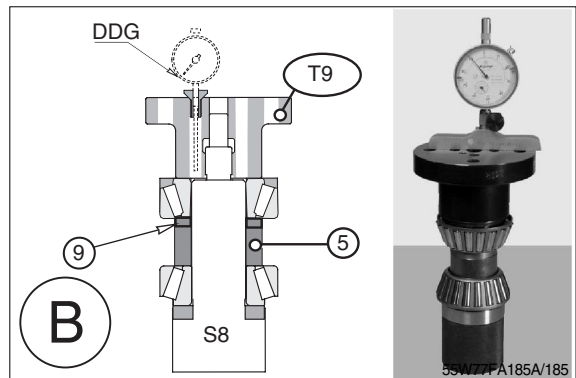

- (13) Calculate the shim S2 to be inserted.
E.g. $S2 = H + X = 3.01\text{mm}$ where X = fixed value to obtain $= 0.07 \dots 0.08\text{mm}$



(14) Heat the bearing(4) to a temperature of about 100°C and fit it on to the pinion(11).

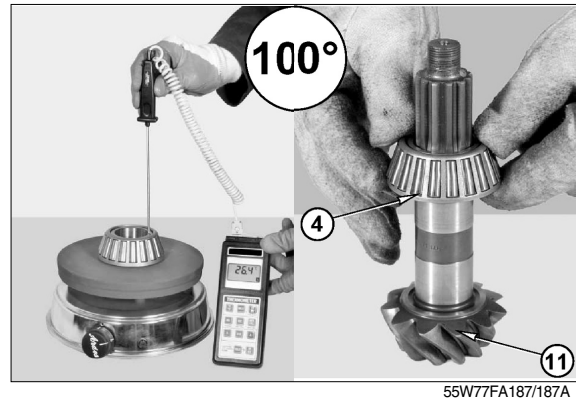

(15) Fit the pinion(11), shim "S1"(10) and distance piece(5)(9) in the main body(12).
※ The finer shims must be placed in-between the thicker ones.

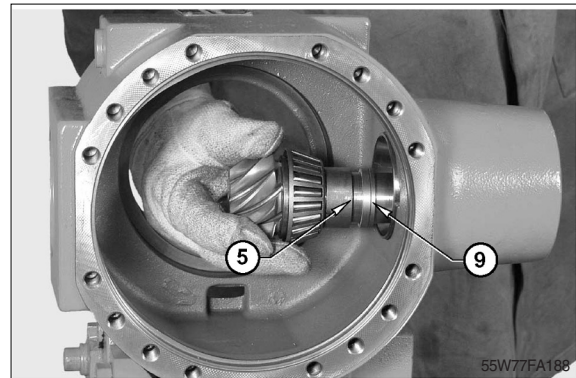

(16) Heat the external bearing(14) to a temperature of about 100°C and fit it on to the pinion(11) so as to complete the pack as shown in the figure.

※ Lightly lubricate bearing with SAE85 W90 oil.

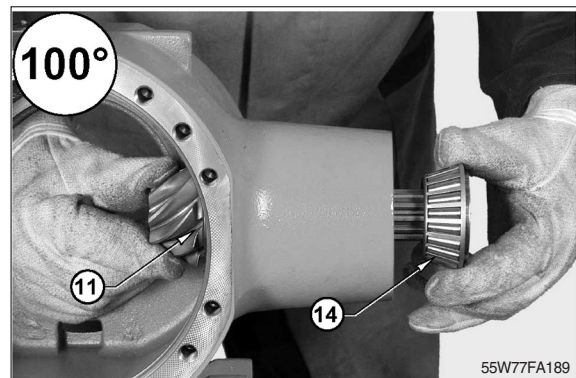

(17) Insert the spacer(8A)

※ Check the using of the friction washers if.

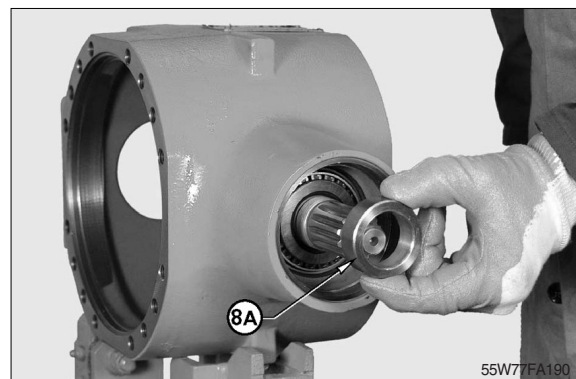

(18) Install the flange(2) onto the pinion(11) without sealing ring.

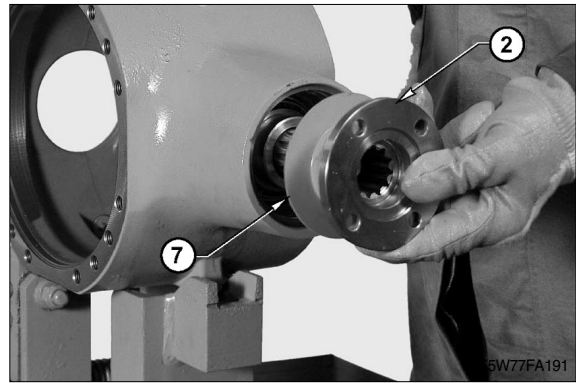

(19) Install the nut(1) without LOCTITE 270.

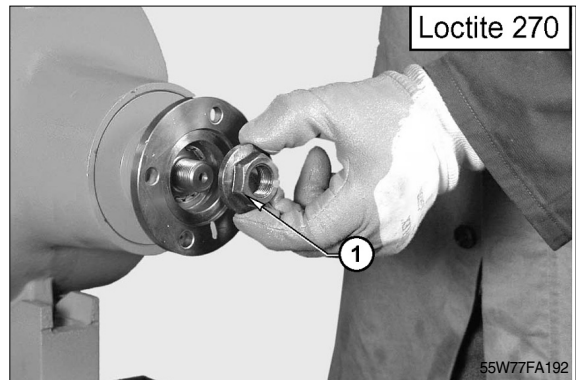

(20) Lock the wrench T5, rotate the pinion using a dynamometric wrench, up to a minimum required torque setting of 260~300Nm(191.7~221.2lbf · ft).

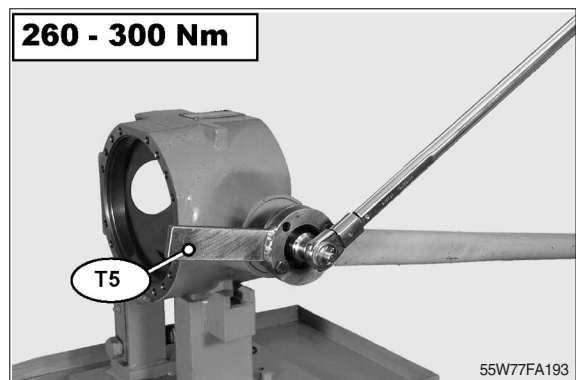

(21) Apply onto the pinion(1) the bar-hold and with the help of a torque metre, check the torque of the pinion(1).

Torque : 80~120Ncm(0.6~0.9lbf · ft)

▲ If torque exceeds the maximum value, then the size of shim "S1"(4) between the bearing(9) and the distance piece(3) needs to be increased.

If torque does not reach the set value, increase the torque setting of the ring nut(10) in different stages to obtain a maximum value of 500Ncm(368.8lbf · ft)

▲ If torque does not reach the minimum value, then the size of shim "S1"(4) needs to be reduced.

▲ When calculating the increase or decrease in size of shim "S1", bear in mind that a variation of shim of 0.01mm corresponds to a variation of 60Ncm(0.44lbf · ft) in the torque of the pinion(1).

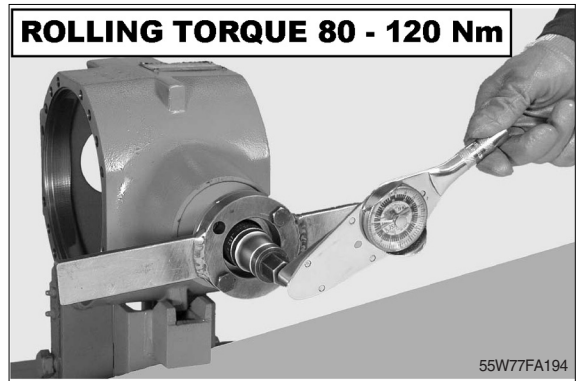

(22) Make positional marks across nut(1) and pinion(11) tang; then remove nut and flange(2)

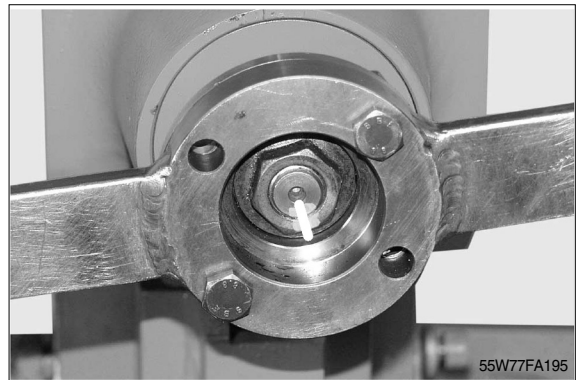

(23) Apply arexons rubber cement to the outer surface of the new seal ring(3) and fit ring in the main body(12) using driver T11.

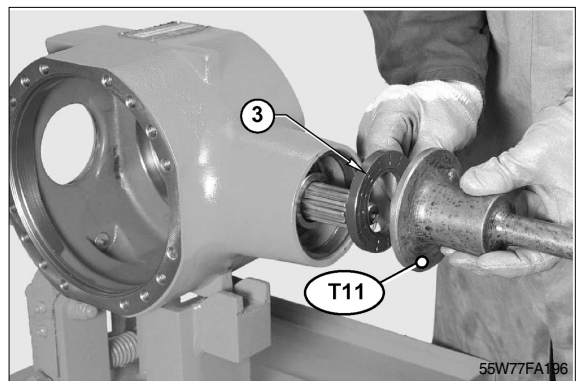

- (24) Oil seal ring lips and install flange(2).
Mount O-ring(6) and apply loctite 270 to pinion tang; tighten nut(1).

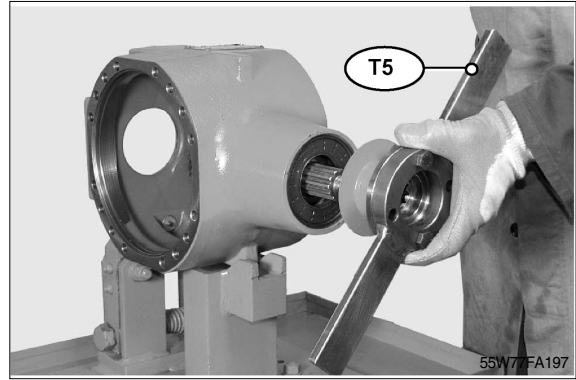

- (25) Tighten the nut until the match marks made at stage "A" line up.

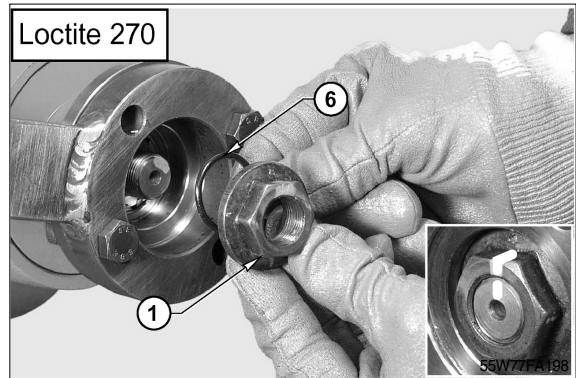

6. RING AND PINION ADJUSTING

1) Step for preloaded differential

- (1) Choose a pack of shims S_b with an initial value of about 0.37mm to place under the brake side bearing's cup.

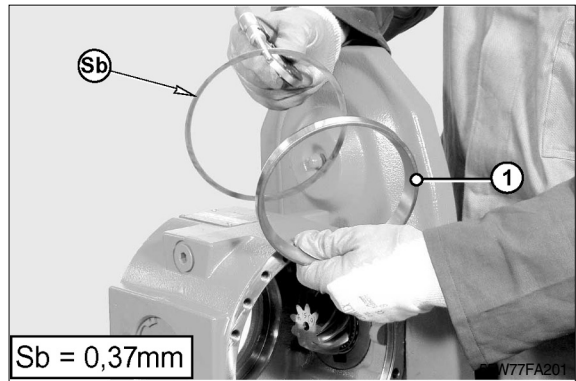

- (2) Assemble the shims S_b , the cup(1) and level.

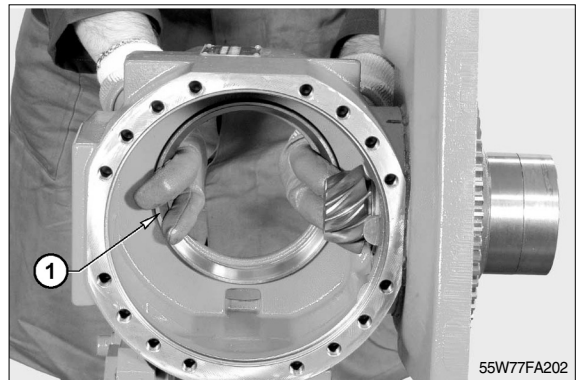

- (3) Remove the snap ring.

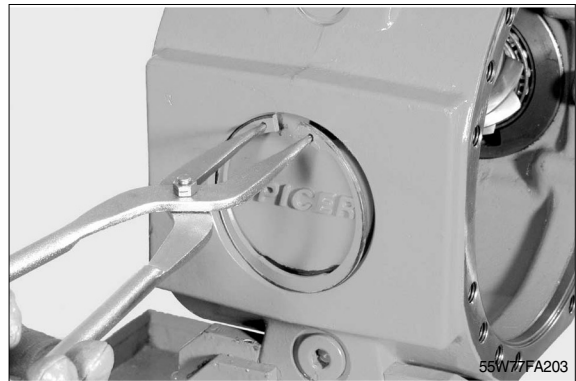

- (4) Remove cap.
※ Do not bend the cap



- (5) Insert the complete differential.
※ Attention do not damage the sealing surface of the O-ring.

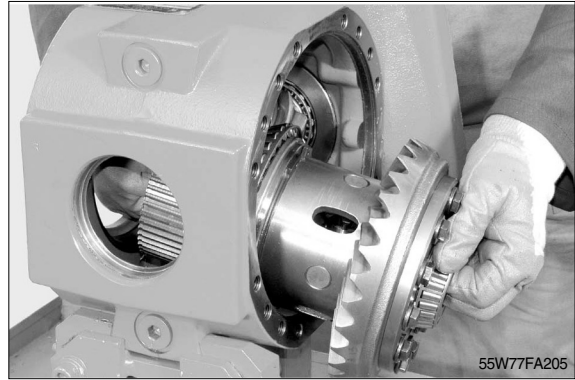

- (6) Choose a pack of shims Sc with an initial value of about 0.84mm to place under the crown wheel side bearing's cup.

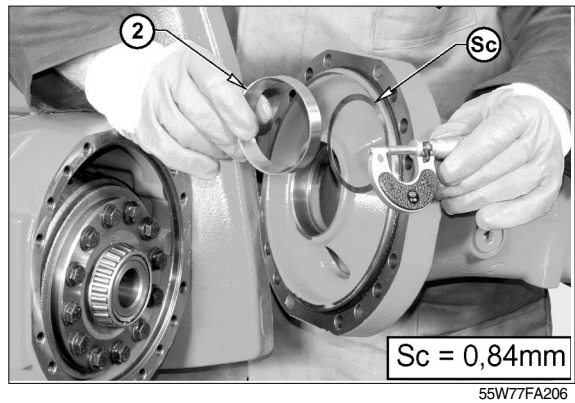

- (7) Assemble the shims Sc, the cup(1) and level.



- (8) Exchange always the O-ring of the arm.



- (9) Position comparator on the centre of one of the crown teeth, preset it to 1mm and reset it to zero. Manually move the crown in both directions to check the existing clearance between pinion and crown.

(Gap = 0.13-0.20mm)

In order to increase the gap while keeping the load on the bearing unchanged, take off shims from the crown wheel side and insert them on the opposite side. In order to decrease the gap, act the other way round. Introduce a comparator with rotary key through the rear cap hole.

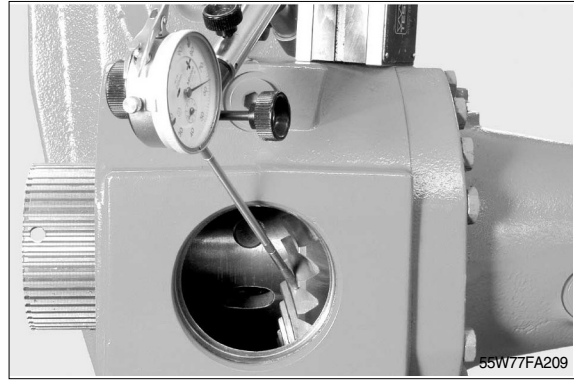

- (10) Assemble rubber cap and snap ring.

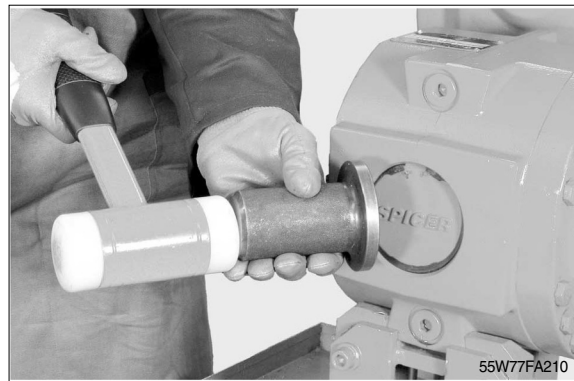

7. PLANETARY REDUCTION AND AXLE SHAFT

1) Disassemble

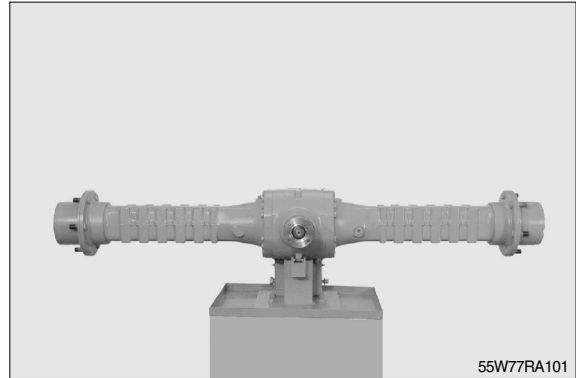

- (1) Remove the oil-level plug(4).
※ Perform all operations on both arms.

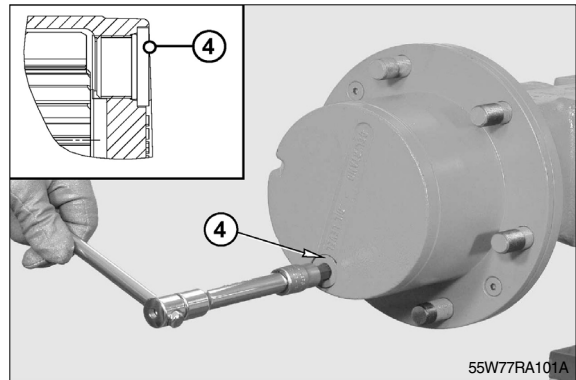

- (2) Remove the securing screws(20) from the spider cover(21).

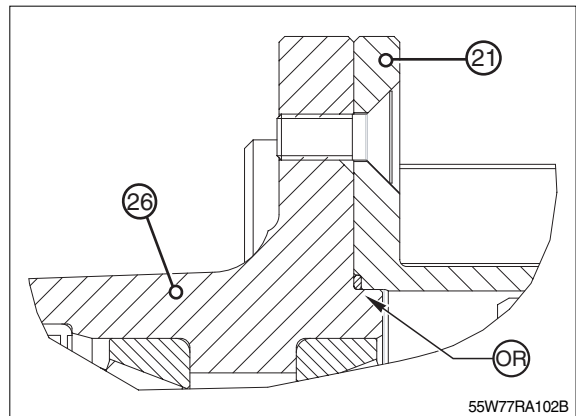
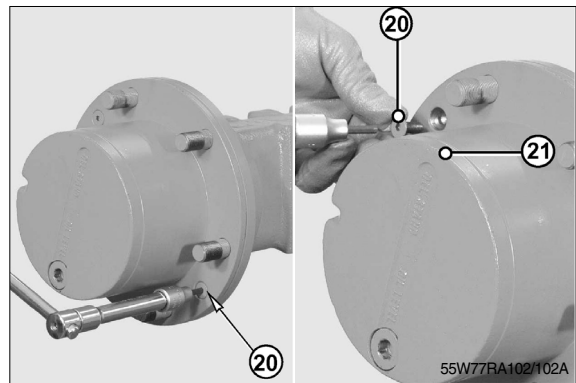

- (3) Disjoin the spider cover(21) from the hub(26) by alternatively forcing a screwdriver into the appropriate slots.

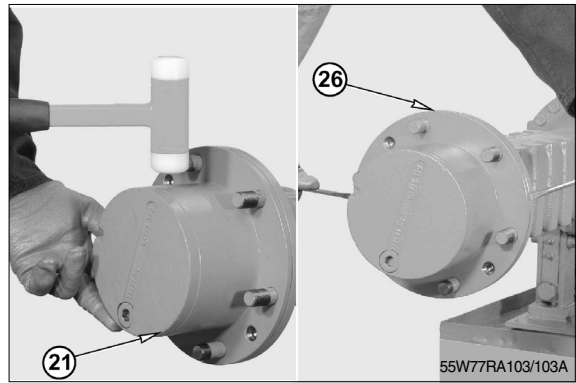

- (4) Remove the complete planetary carrier cover(21).

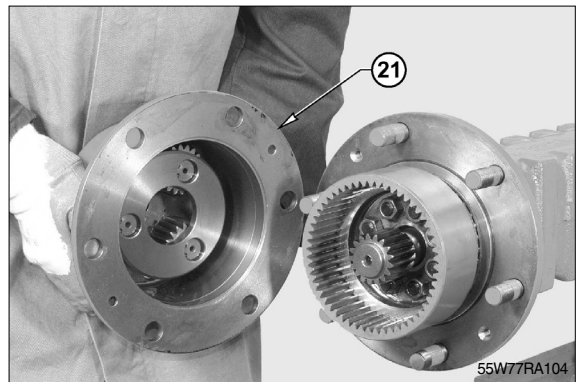

- (5) Remove the complete axle-shaft(27).

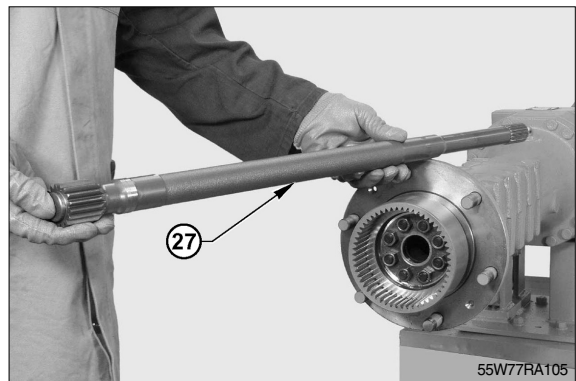

- (6) Unloose and remove the tightening nuts (23) from the crown flange(13).

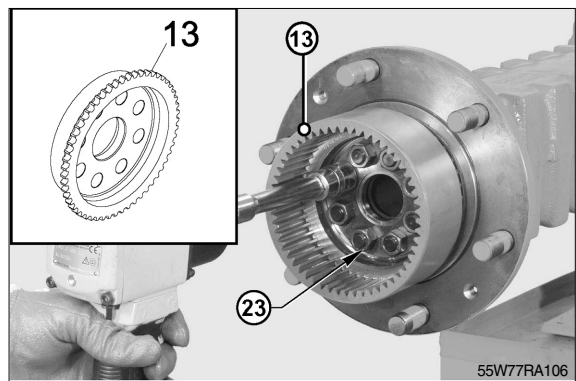

(7) Remove the safety flange(14).

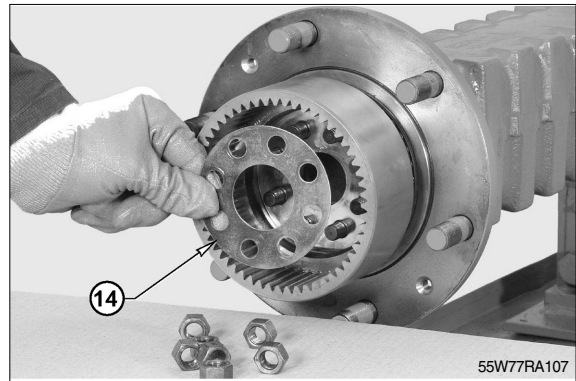

(8) Remove the crown(12).

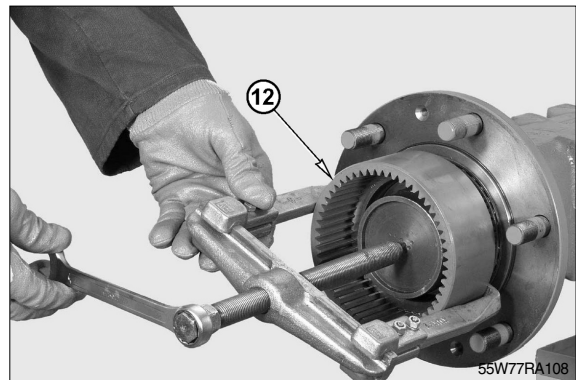

(9) Partially extract the hub(26) using a plastic hammer.
※ Alternately hammer on several equidistant points.

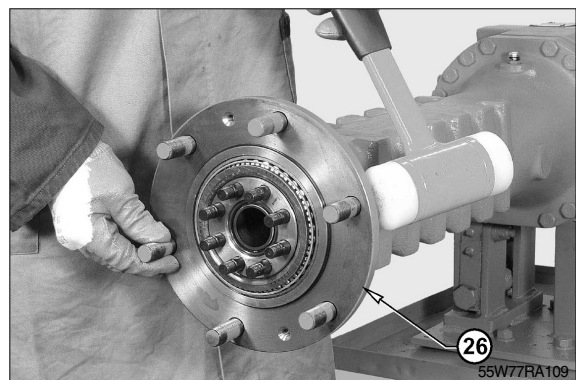

(10) Remove the external bearing(31).

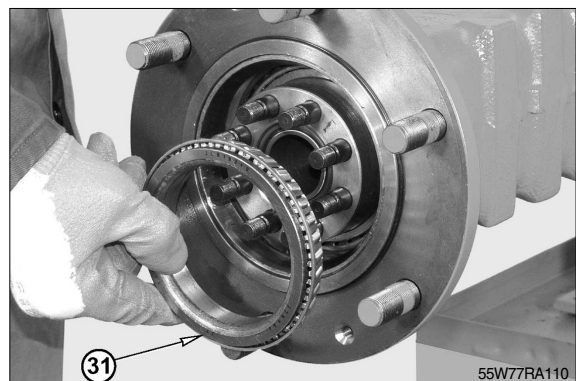

(11) By hand remove complete hub(26).

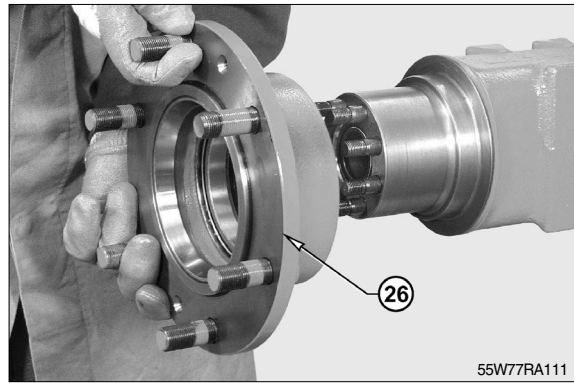

(12) Using an extractor, remove the seal ring (6).

※ Note down the direction of assembly of snap ring.

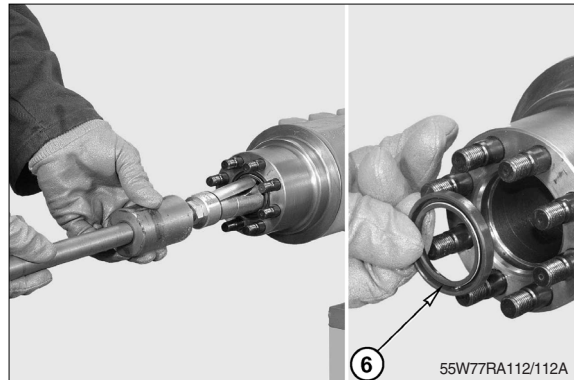

(13) Remove snap ring(15).

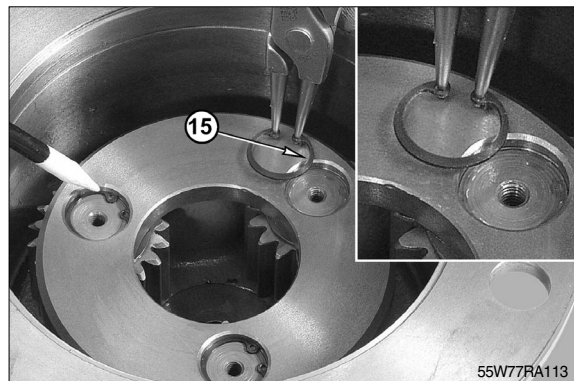

(14) Using a screw M6 remove all bolts(16).

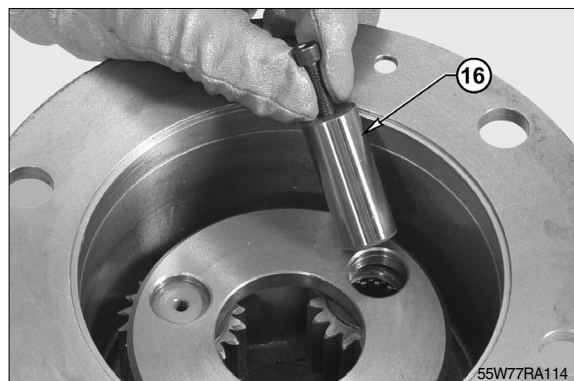

(15) Positioning the planet wheel gear(17) in center of the spider cover and remove.

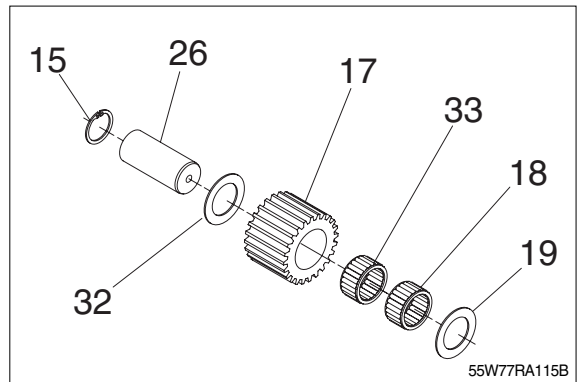
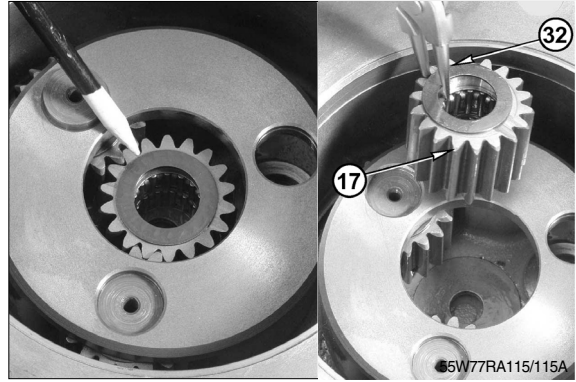

(16) Remove the sealing ring(7) from the hub (26).

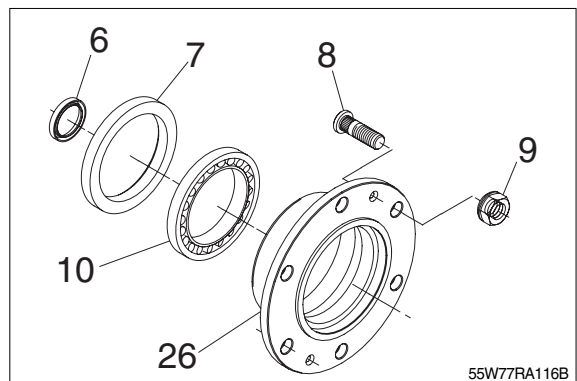
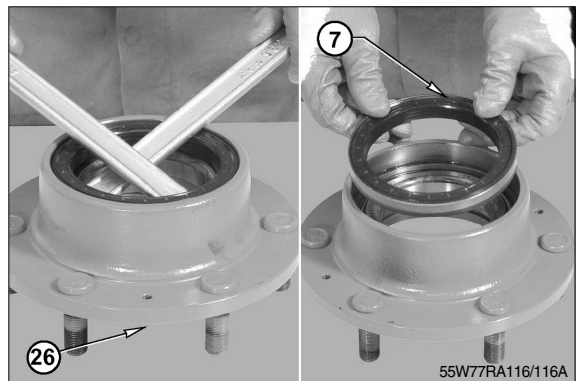

(17) Remove the internal bearing(10).

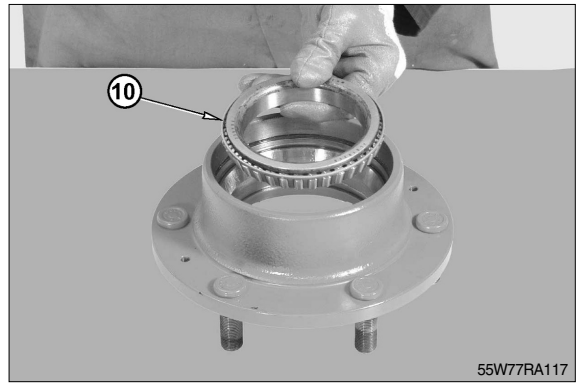

(18) Remove the thrust blocks(10)(31) from the bearings and forcing a pin-driver into the appropriate slots on the hub.

※ Hammer in an alternate way so as to avoid crawling or deformation of the thrust blocks.

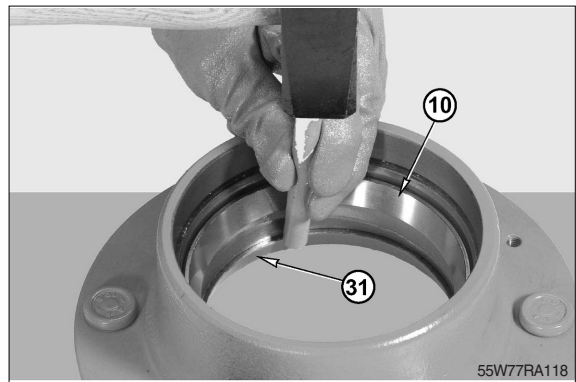

(19) Remove the snap ring(12) from the crown (13).

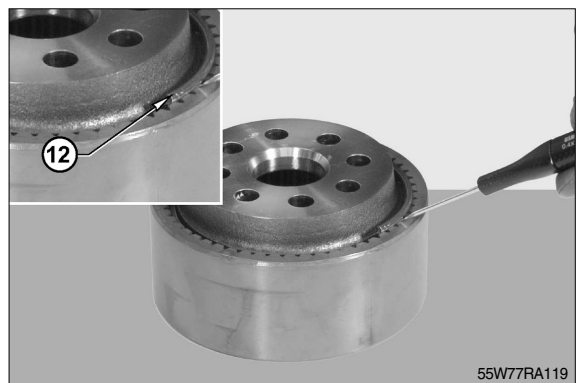

(20) Remove the crown flange(13).

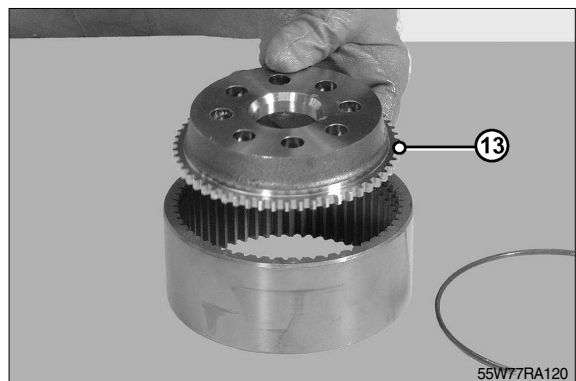

2) Assembly

- (1) Lubricate and fit the sealing ring(6) onto tool T3; install the rings into the arm.

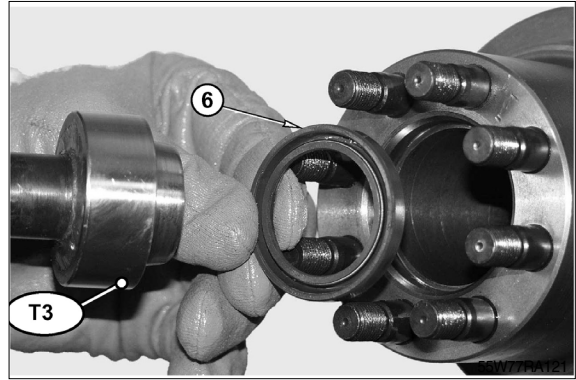

- (2) Pay particular attention to the direction of assembly of the rings.

※ Caution!

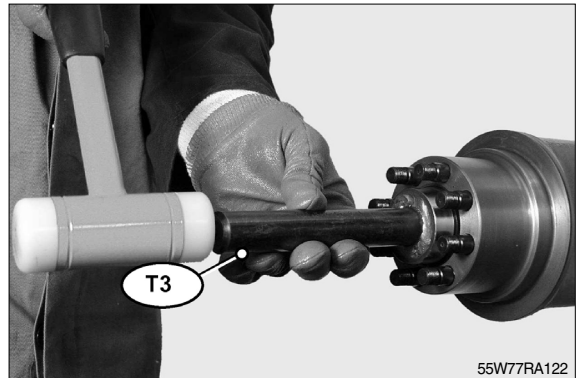

- (3) Position the lower part of tool T1 and the thrust block of the external bearing(31).

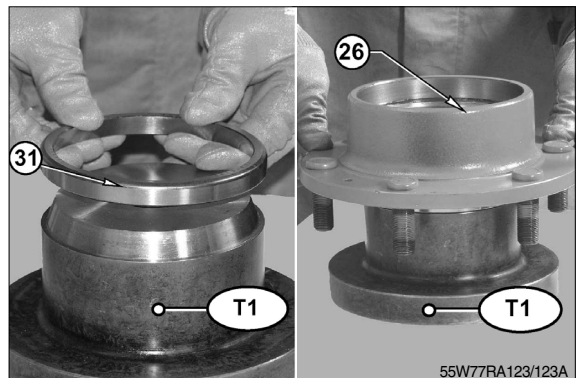

- (4) Lubricate the seats of the bearings and position the hub on tool T1; position the thrust block of the internal bearing(10).

※ Check that the thrust block is correctly oriented.

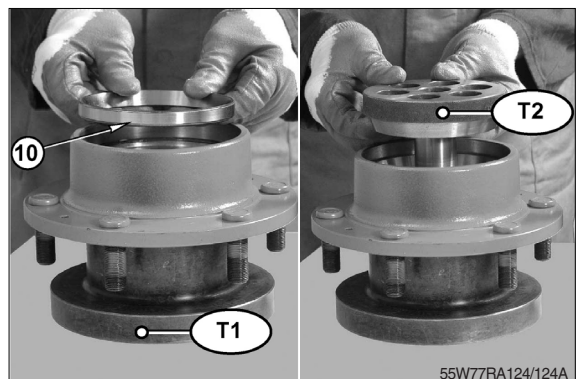

- (5) Fit the bearing(10) into the internal thrust block.

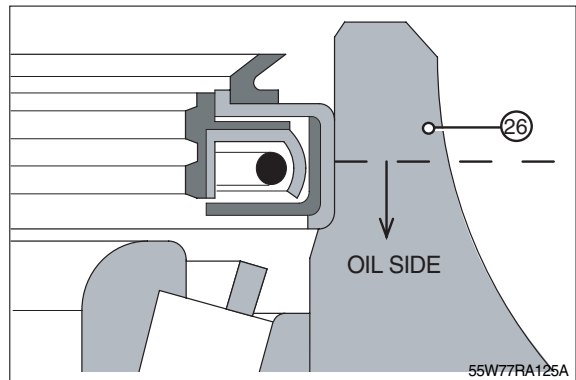
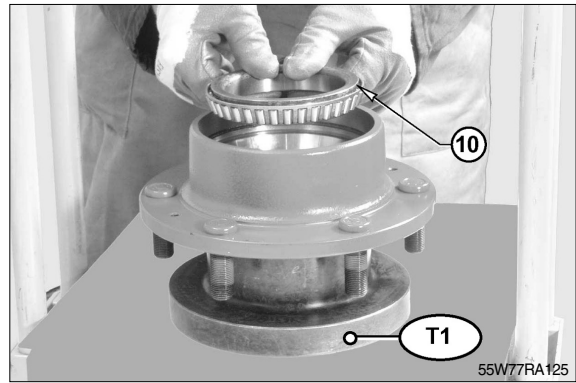

- (6) Using special tool T2 apply a repositionable jointing compound for seals to the outer surface of the sealing ring(7).
Position the sealing ring(7) in the hub(26).
※ Check that the ring(7) is correctly oriented.

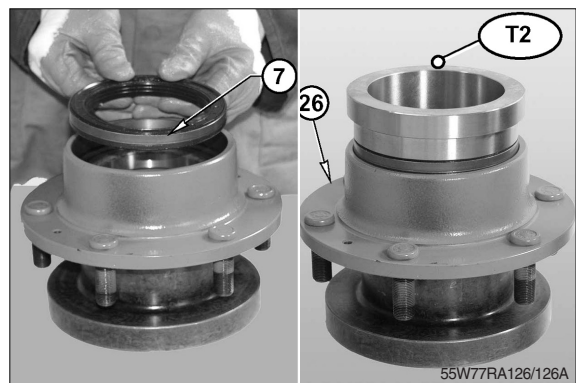

- (7) Install the wheel hub(26).

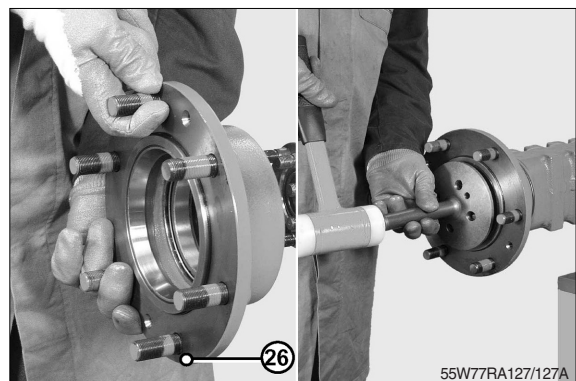

- (8) Install the external bearing(31).
※ Move the bearing to the limit stop by hammering lightly all around the edge.

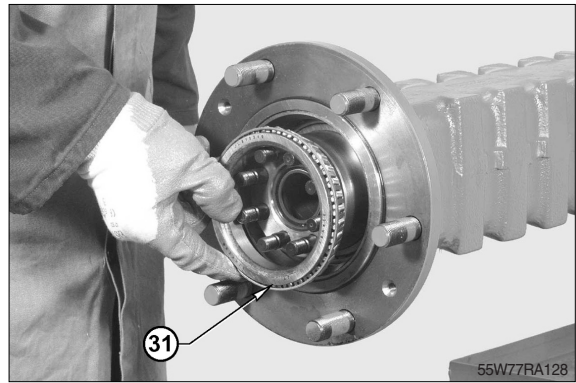

- (9) Install the crown wheel(12).
Insert the snap ring(11) in order to fix the flange(13) in the crown(12).
※ Carefully check that ring(11) is properly inserted in the slot of the crown(12).

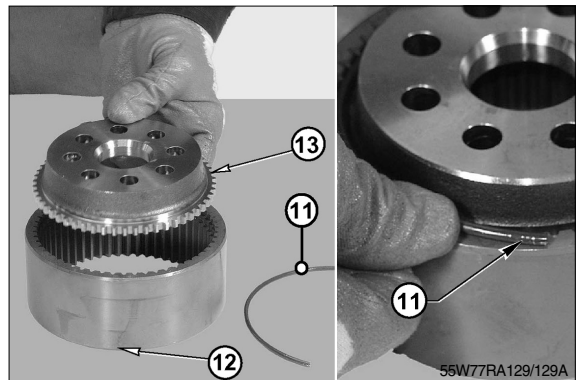

- (10) Fit the complete crown flange.
※ In order to fasten the flange, use a plastic hammer and alternately hammer on several equidistant points.

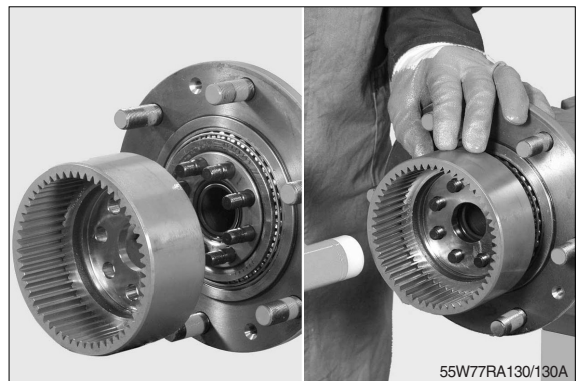

- (11) Install the security flange(14).

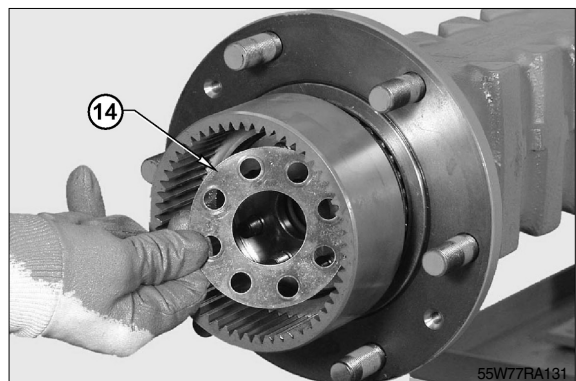

- (12) Coat the nuts(23) with loctite 242 and screw them.

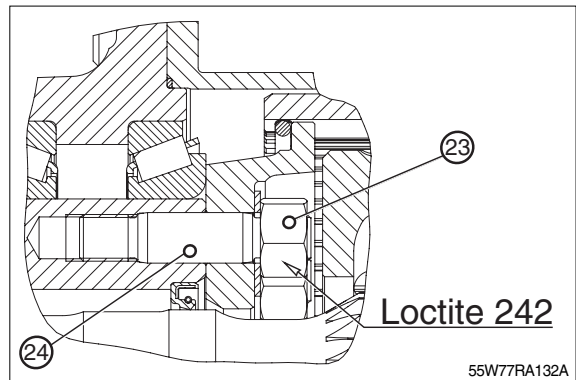
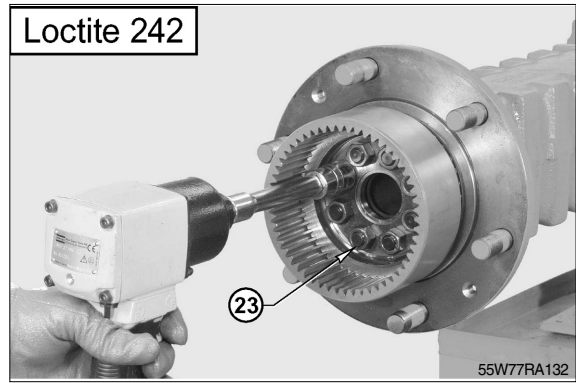

- (13) Tighten nuts(23) in two stages, using the criss-cross method.
Initial torque wrench setting : 90Nm
(69.3lbf · ft)
Final torque wrench setting : 100Nm
(73.7lbf · ft)

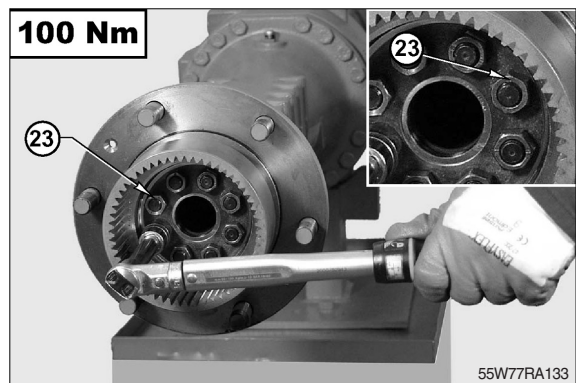

- (14) Check the continuous rolling torque on the hub.
Torque 7~20Nm(5.1~14.7lbf · ft)

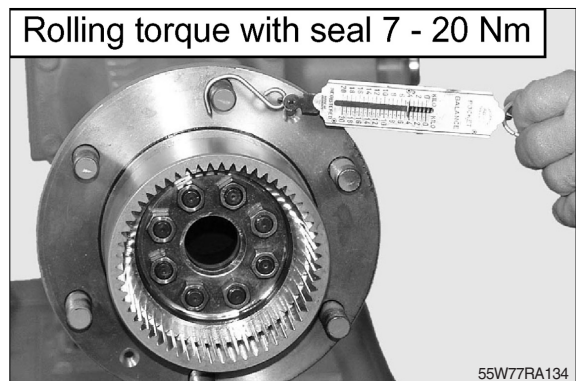

(15) Install the axle shaft(27), making sure that it is properly inserted into braking disks and differential unit.

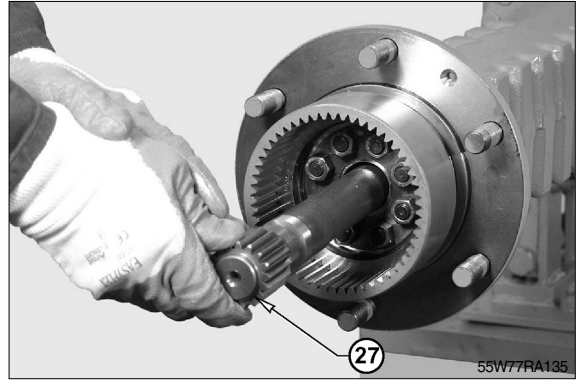

(16) Check the condition and position of the O-ring(25).
※ Caution!

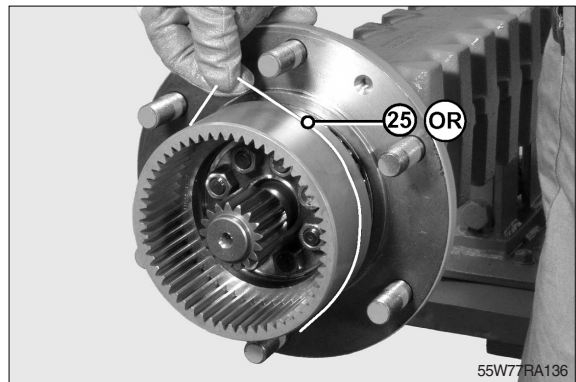

(17) Install the spherical washer(19).

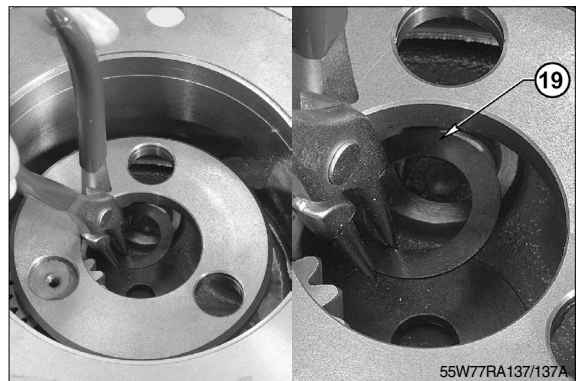

(18) Install planetary gears complete with roller bearing(17).

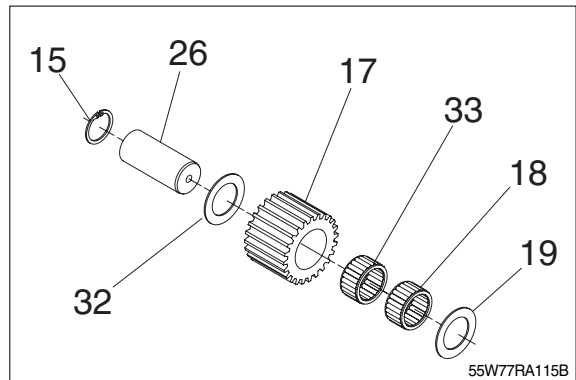
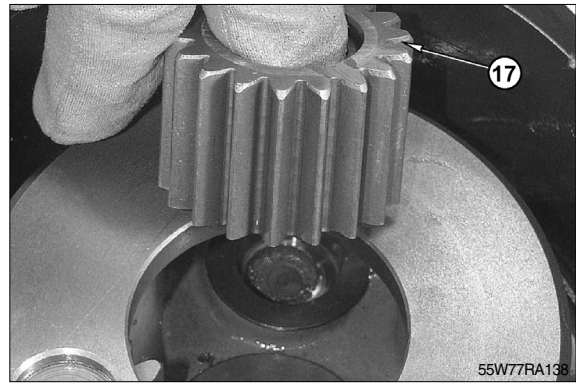

(19) Install the others friction washers.

※ Two friction washers for every planetary gear.

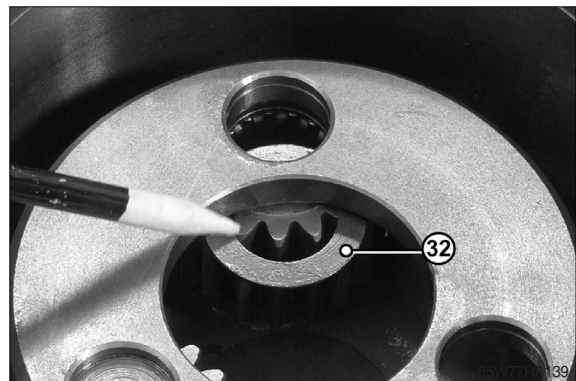

(20) Check the concentricity of the planetary gear, the seat and friction washers.
Using a screw M6 install the pin(16).

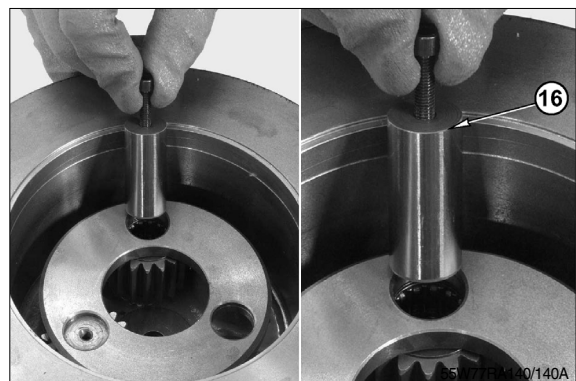

(21) Carefully check that pin is completely inserted and install the snap rings(15).

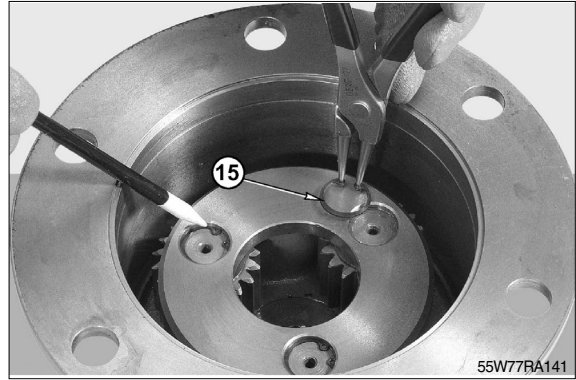

(22) Fit the planetary gear cover(21) onto the wheel hub(26).

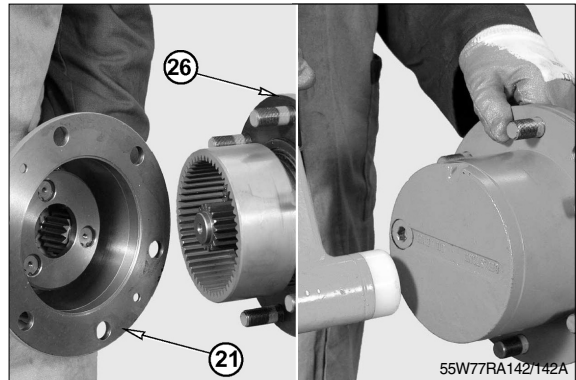

(23) Torque wrench 20~25Nm(14.8~18.4lbf · ft)

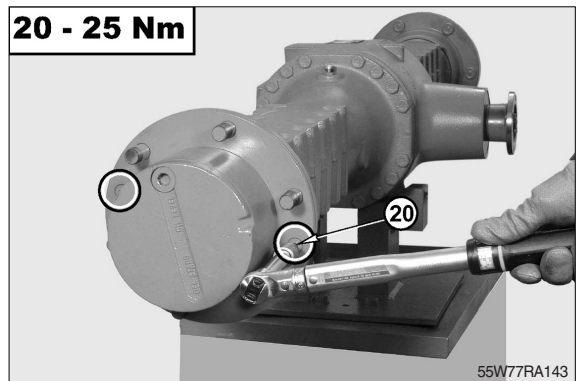

8. SPECIAL TOOLS

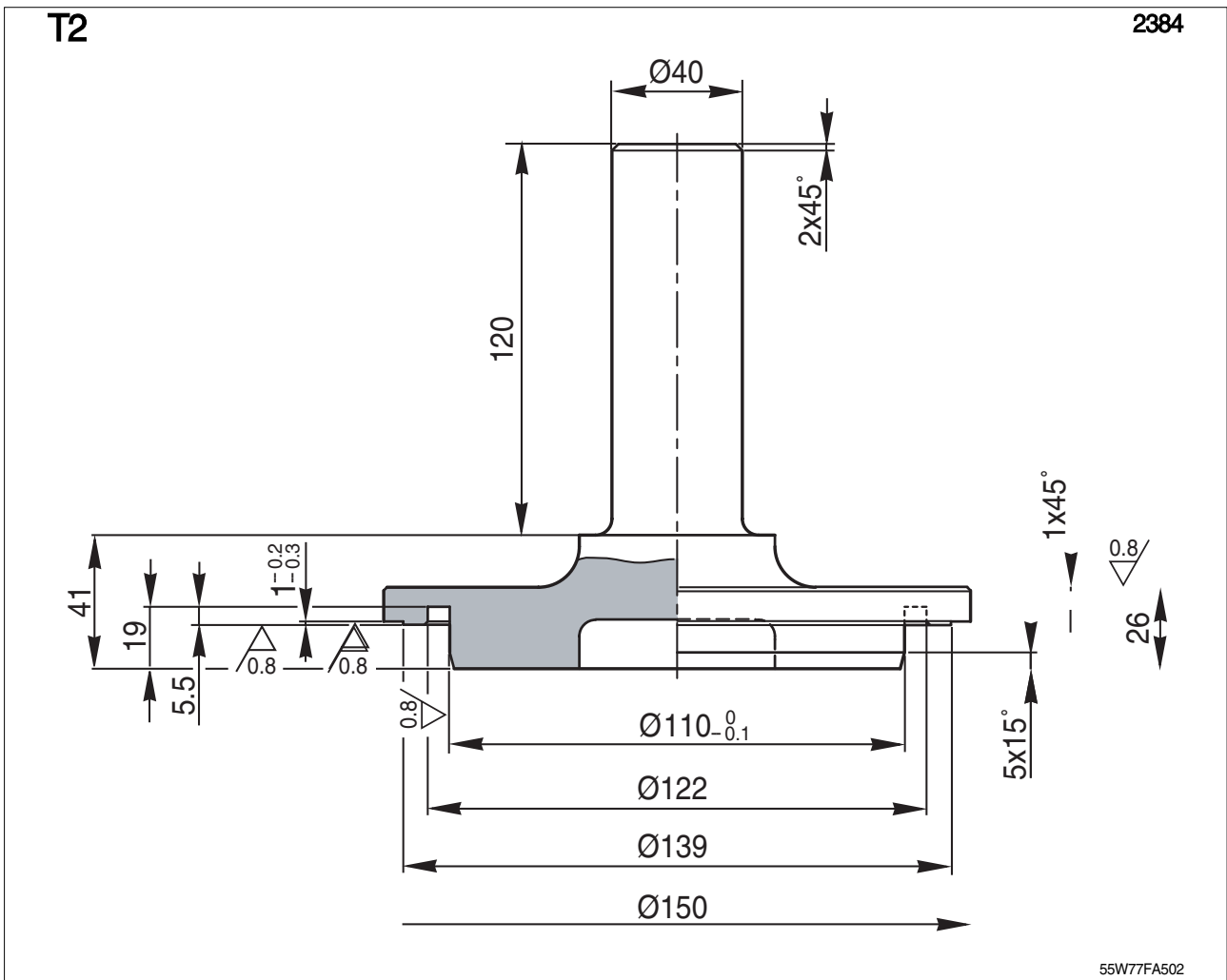
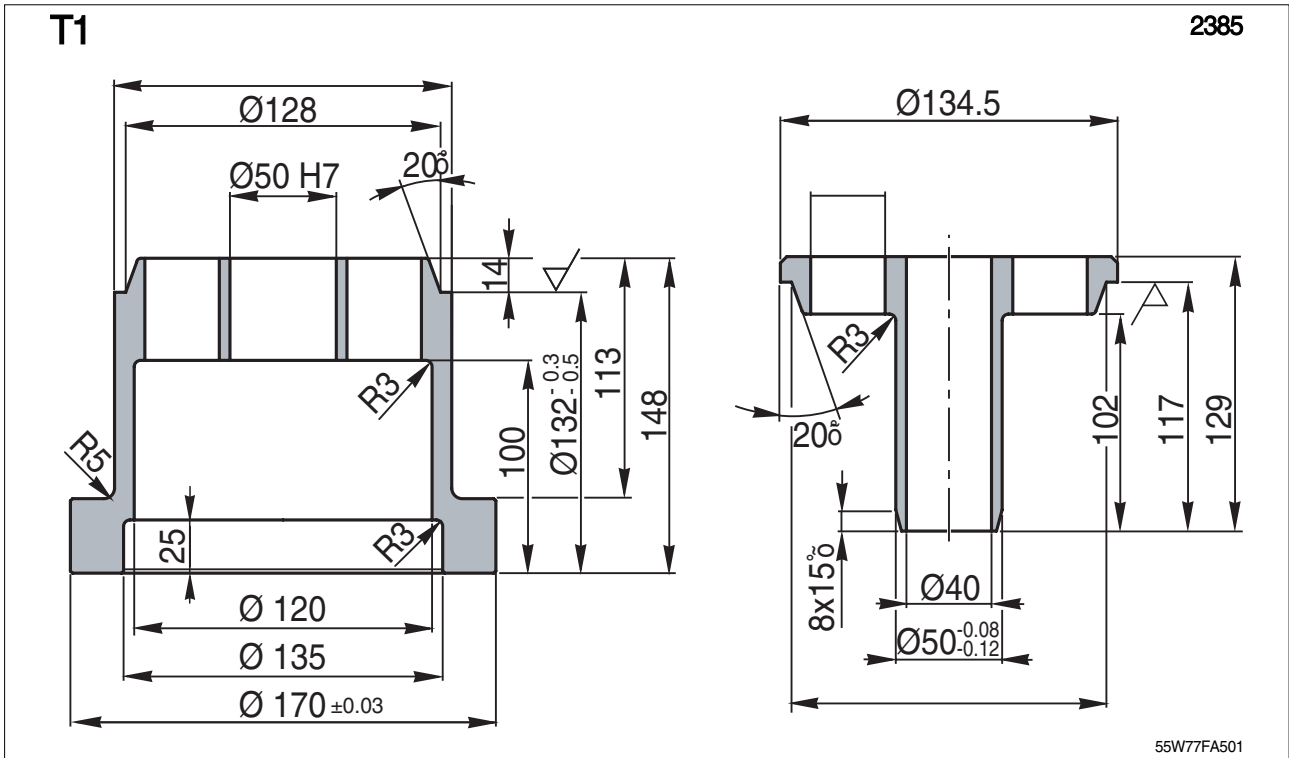

T3

2387

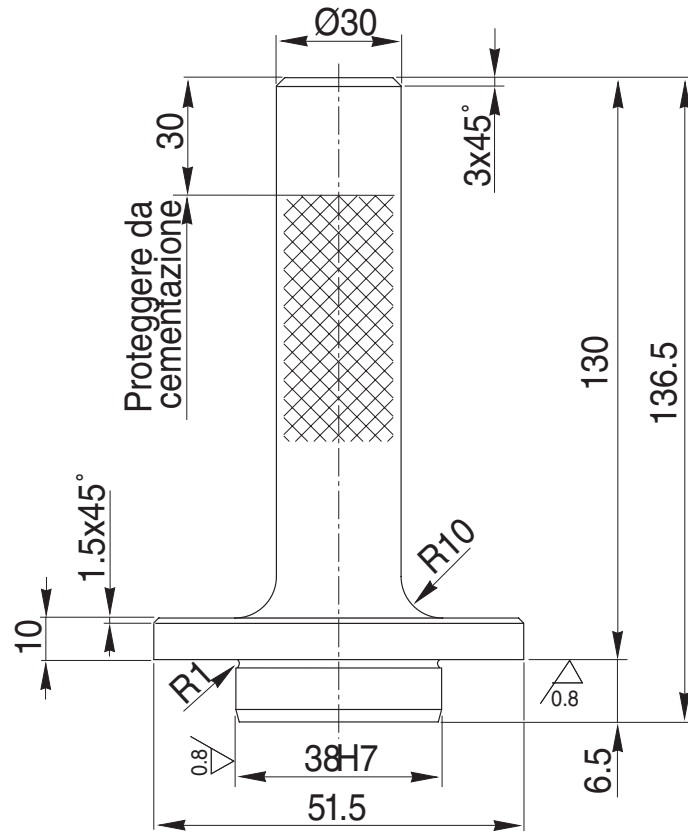

55W77FA503

T4

2388

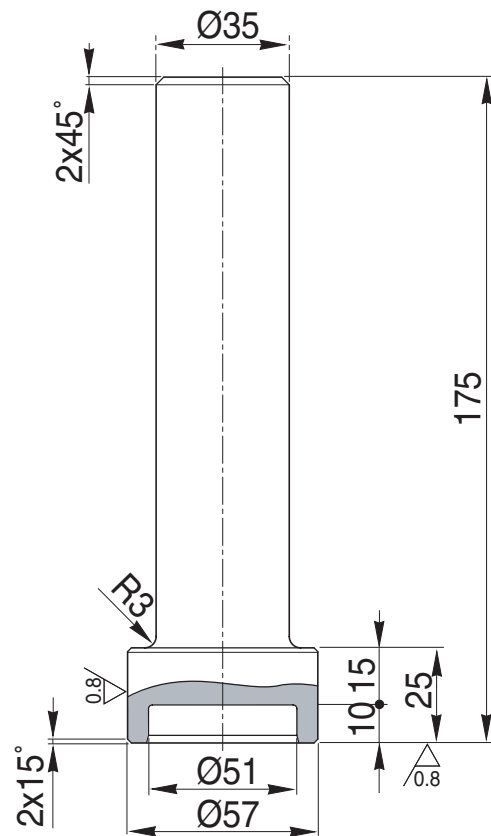

55W77FA504

4 fori d. 9,5	Flangia END YOKE 315.14.011.02
3 fori d.10,2 a 120°	Flangia DIN 100 171.04.040.02
2 fori d.12 a 180°	Flangia DIN 100 542.22.004.05

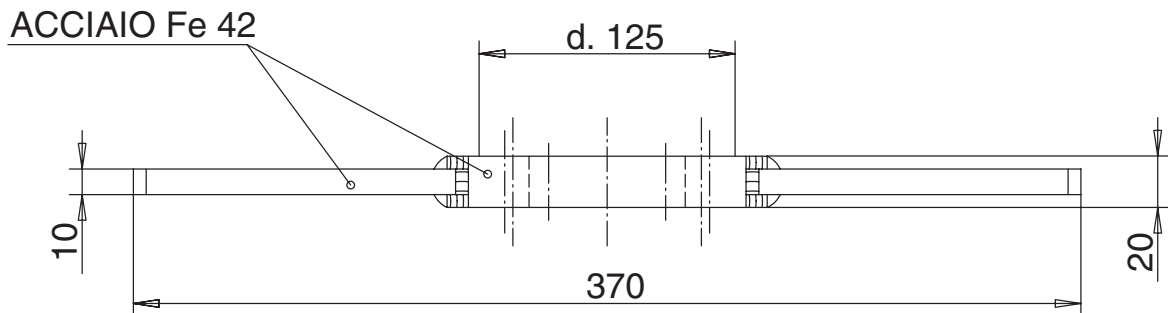
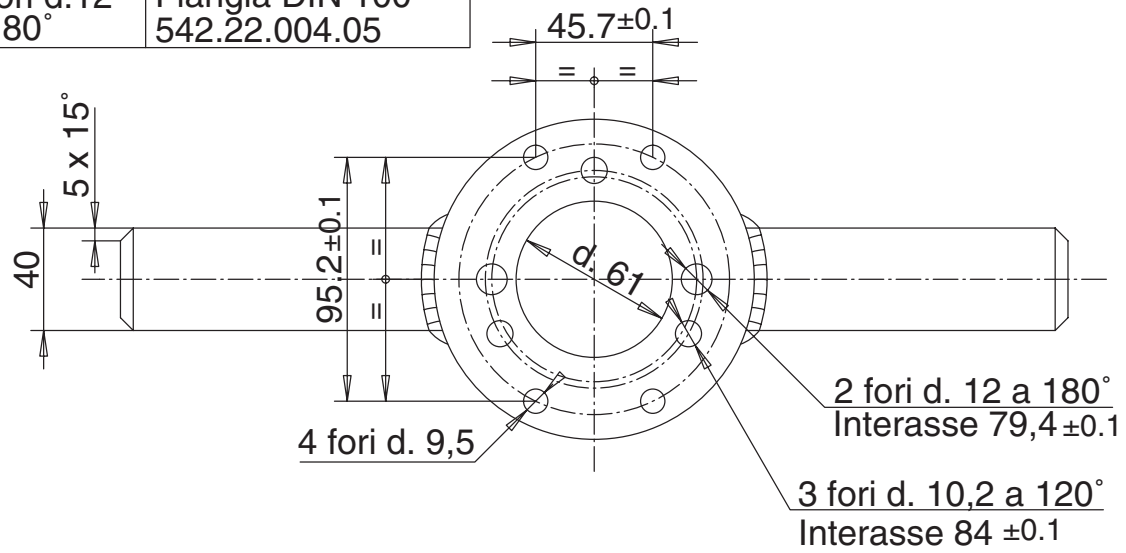

T6

1332

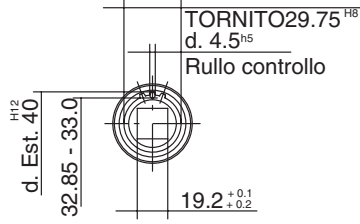
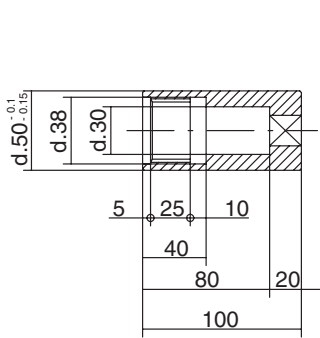

PROFILO N35 x 2,5 x 12 x 7H - DIN 5480
N° DENTI Z=12
MODULO M=2,5
SPOST. PROFILO xm+1,125
ANGOLO DI PRESSIONE 30°

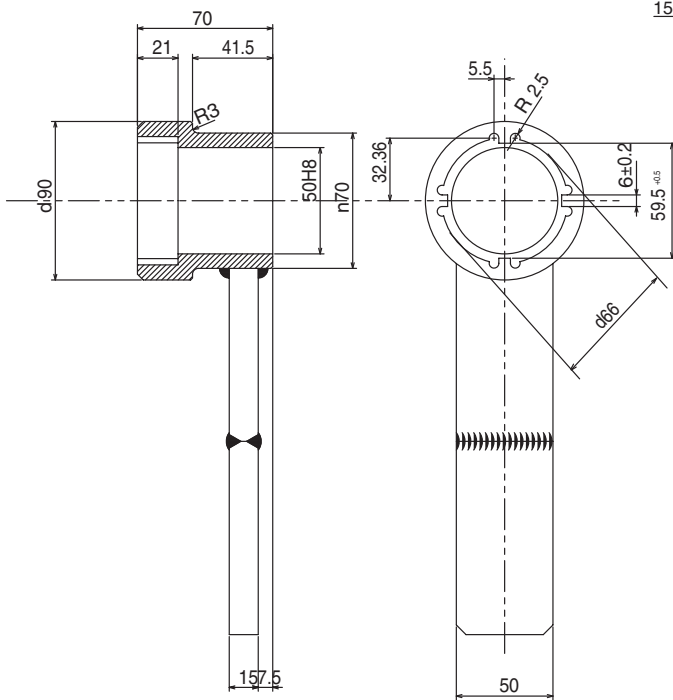
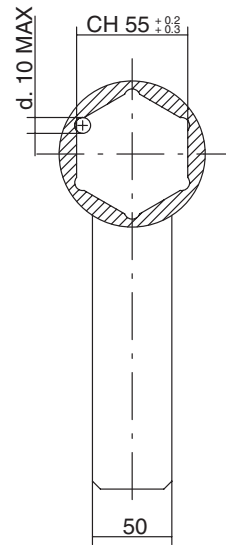
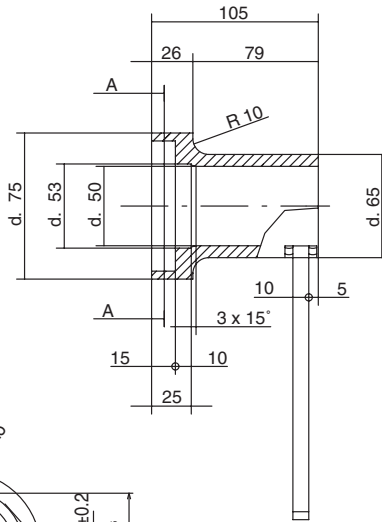

55W77FA506

T7

861

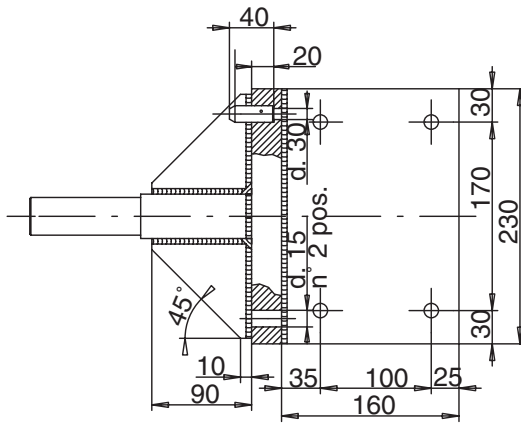
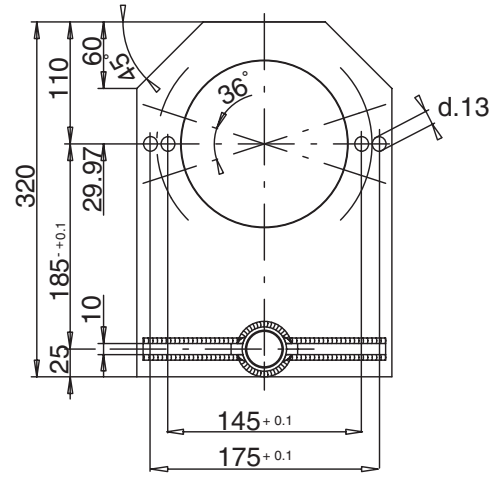
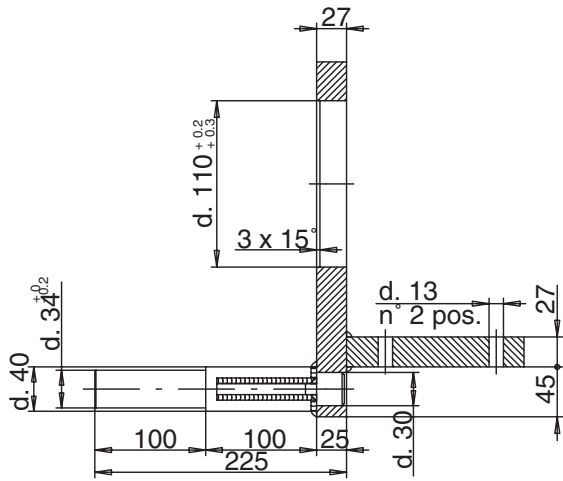

55W77FA507

T8 2 PIECES

1330

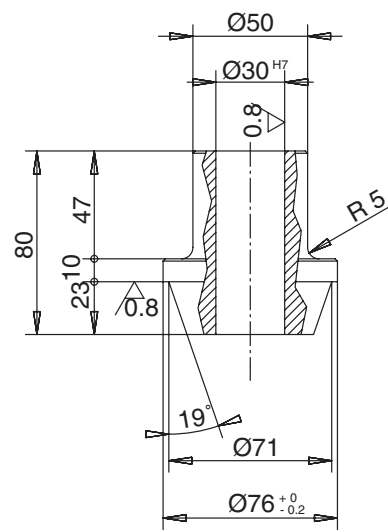
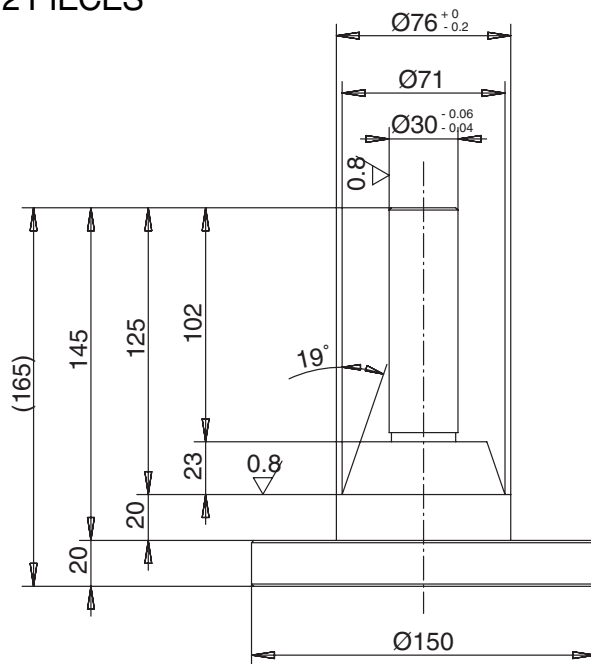

55W77FA508

T9

2389

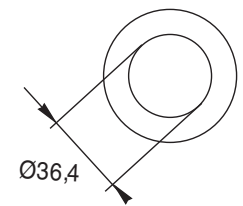
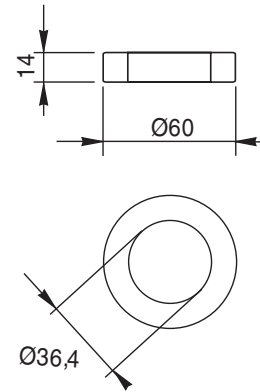
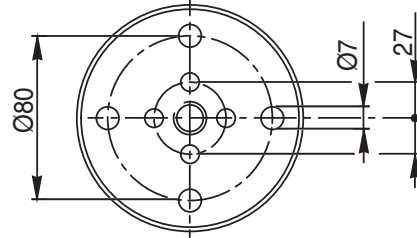
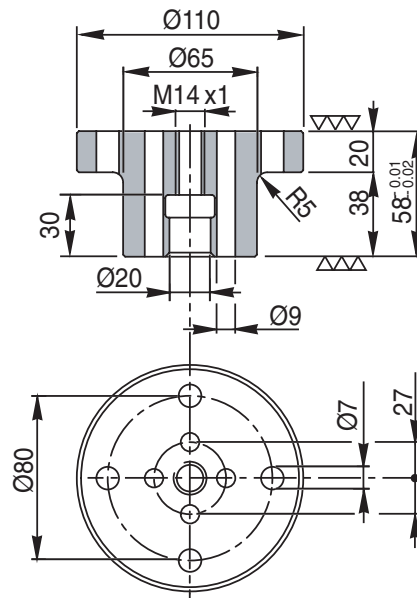
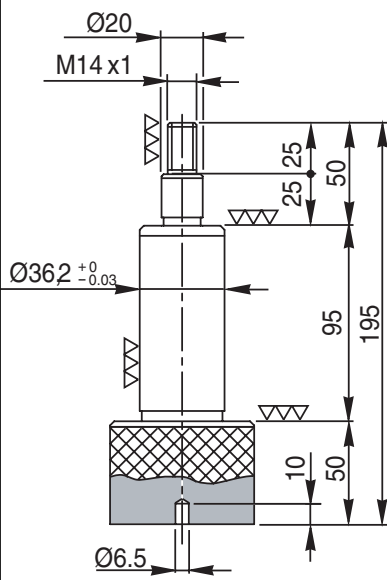

55W77FA509

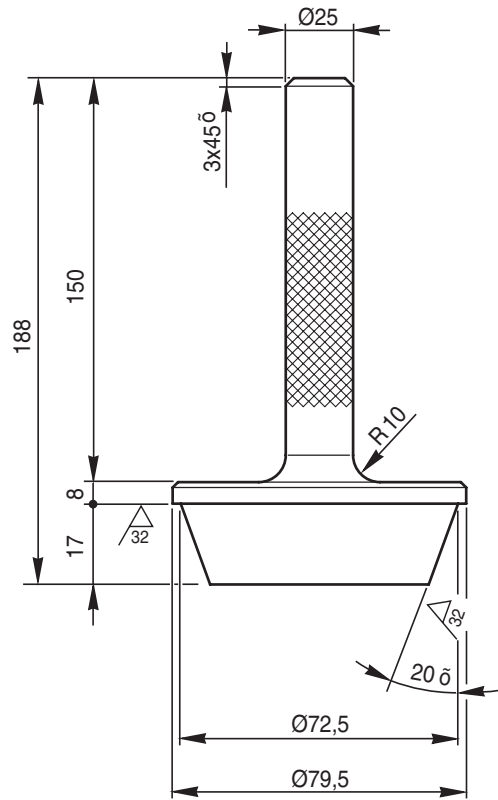

CUSCINETTO 005.09.2938(HM89449-HM89410)

SCATOLA CENTRALE 221.01.001.

ANELLO DI TENUTA 001.03.0730(55x90x10)

ATTREZZO 660.38.4214

PIGNONE CONICO 171.04.043.

DISTANZIALE 111.04.038.01

DISTANZIALE CALIBRATO 315.14.010.

DISTANZIALE CALIBRATO 315.14.009.

DISTANZIALE 111.04.038.01

CUSCINETTO 005.09.2938(HM89449-HM89410)

