

GROUP 3 SWING DEVICE

1. STRUCTURE

Swing device consists swing motor, swing reduction gear.

1) SWING MOTOR

Swing motor include mechanical parking valve, relief valve, make up valve and time delay valve.

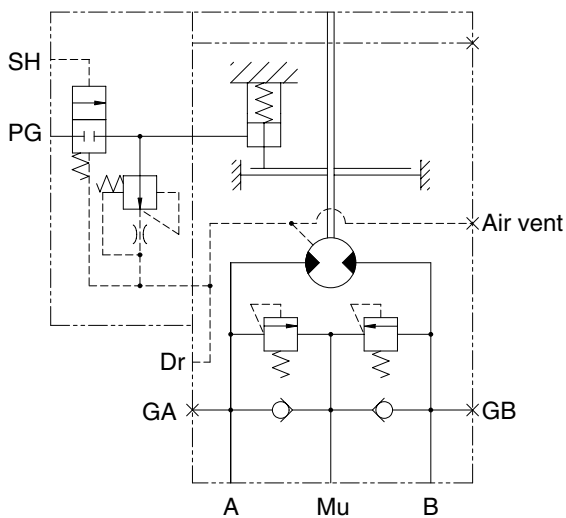
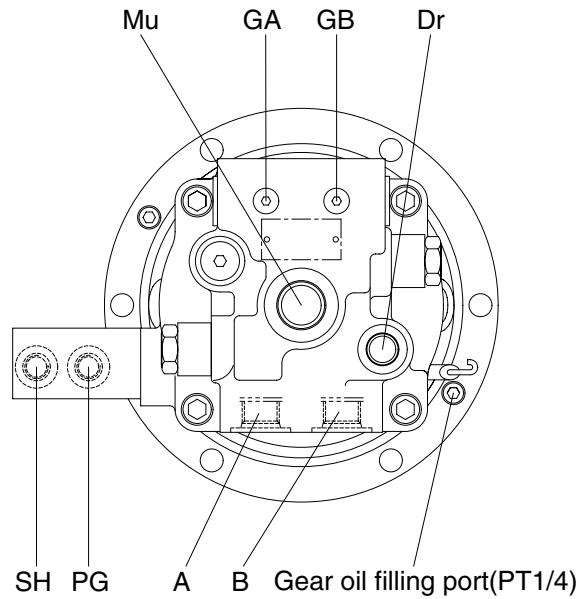
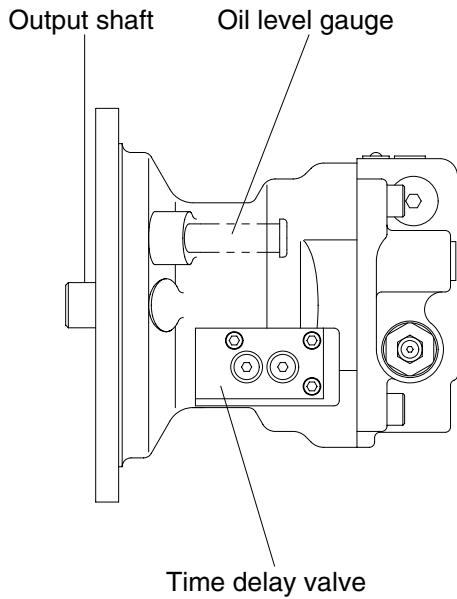

Hydraulic circuit

Port	Port name	Port size
A	Main port	SAE PF 1/2
B	Main port	SAE PF 1/2
Dr	Drain port	PF 3/8
Mu	Make up port	PF 3/4
PG	Brake release port	PF 1/4
SH	Brake pilot port	PF 1/4
GA,GB	Gage port	PF 1/4

55W72SM01

(1) STRUCTURE

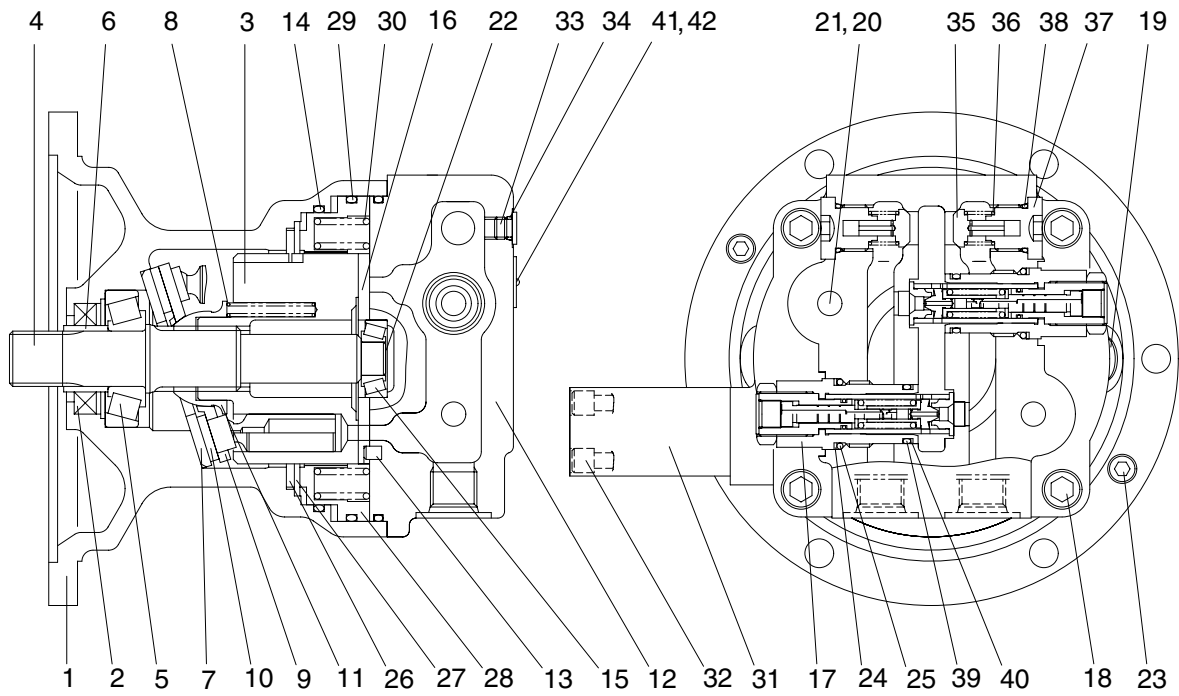

R5572SF33

1	Body	15	Taper bearing	29	O-ring
2	Oil seal	16	Valve plate	30	Spring
3	Cylinder block	17	Relief valve assy	31	Time delay valve
4	Shaft	18	Socket bolt	32	Socket bolt
5	Taper bearing	19	Plug	33	Plug
6	Bushing	20	Plug	34	O-ring
7	Shoe plate	21	O-ring	35	Valve
8	Spring	22	Shim	36	Spring
9	Set plate	23	Plug	37	Plug
10	Piston shoe assy	24	Back up ring	38	O-ring
11	Ball guide	25	O-ring	39	O-ring
12	Rear cover	26	Friction plate	40	Back up ring
13	Pin	27	Plate	41	Name plate
14	O-ring	28	Parking piston	42	Rivet

2) REDUCTION GEAR

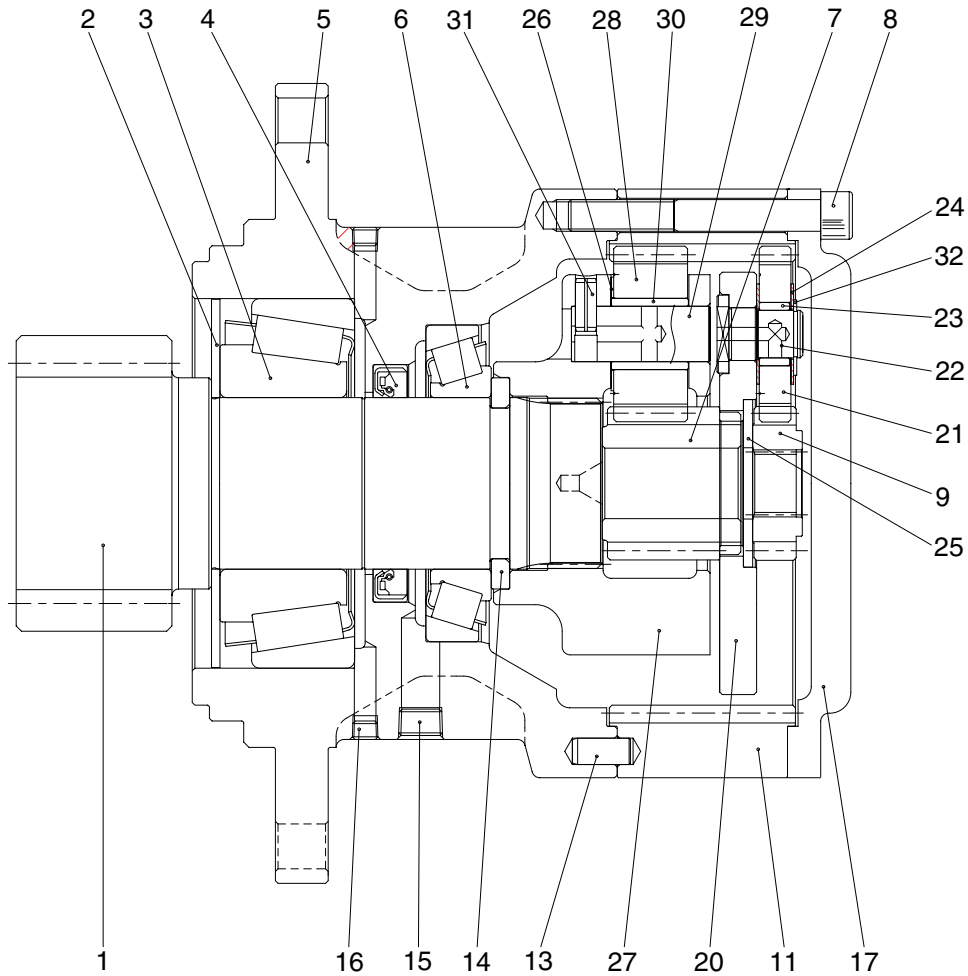

55W72SM02

1	Drive shaft	12	Carrier 2 assy	23	Bushing 1
2	Bearing cover	13	Dowel pin	24	Thrust washer 1
3	Taper roller bearing	14	Collar	25	Thrust washer 3
4	Case	15	Plug	26	Thrust washer 2
5	Oil seal	16	Plug	27	Carrier 2
6	Taper roller bearing	17	Cover	28	Planet gear 2
7	Sun gear 2	18	Pipe	29	Pin 2
8	Socket bolt	19	Level gauge	30	Bushing 2
9	Sun gear 1	20	Carrier 1	31	Spring pin
10	Carrier 1 assy	21	Planet gear 1	32	Snap ring
11	Ring gear	22	Pin 1	33	Thrust washer 4

2. FUNCTION

1) ROTARY PART

When high pressurized oil enters a cylinder through port(a), which is the inlet of balance plate(16), hydraulic pressure acting on the piston causes axial force F. The pressure force F works via the piston(10) upon the return plate(9) which acts upon the swash plate(7) via an hydrostatic bearing. Force F1 perpendicular to swash plate(7) and force F2 perpendicular to cylinder center.

Being transferred to the cylinder block(3) through piston, force F2 causes rotational moment at surroundings of cylinder.

Since cylinder block has 9 equidistantly arrayed pistons, rotational torque is transmitted to cylinder shaft in order by several pistons connected to the inlet port of high pressurized oil. When the direction of oil flow is reversed, rotational direction of cylinder is also reversed. Output torque is given by the equation.

$$T = \frac{p \times q}{2\pi}, q = Z \cdot A \cdot \text{PCD} \cdot \tan\theta, F1 = \frac{F}{\cos\theta}, F2 = F \tan\theta, S = \text{PCD} \times \tan\theta$$

Where p : Effective difference of pressure(kgf/cm²)

q : Displacement(cc/rev)

T : Output torque(kgf · cm)

Z : Piston number(9EA)

A : Piston area(cm²)

θ : Tilting angle of swash plate(degree)

S : Piston stroke(cm)

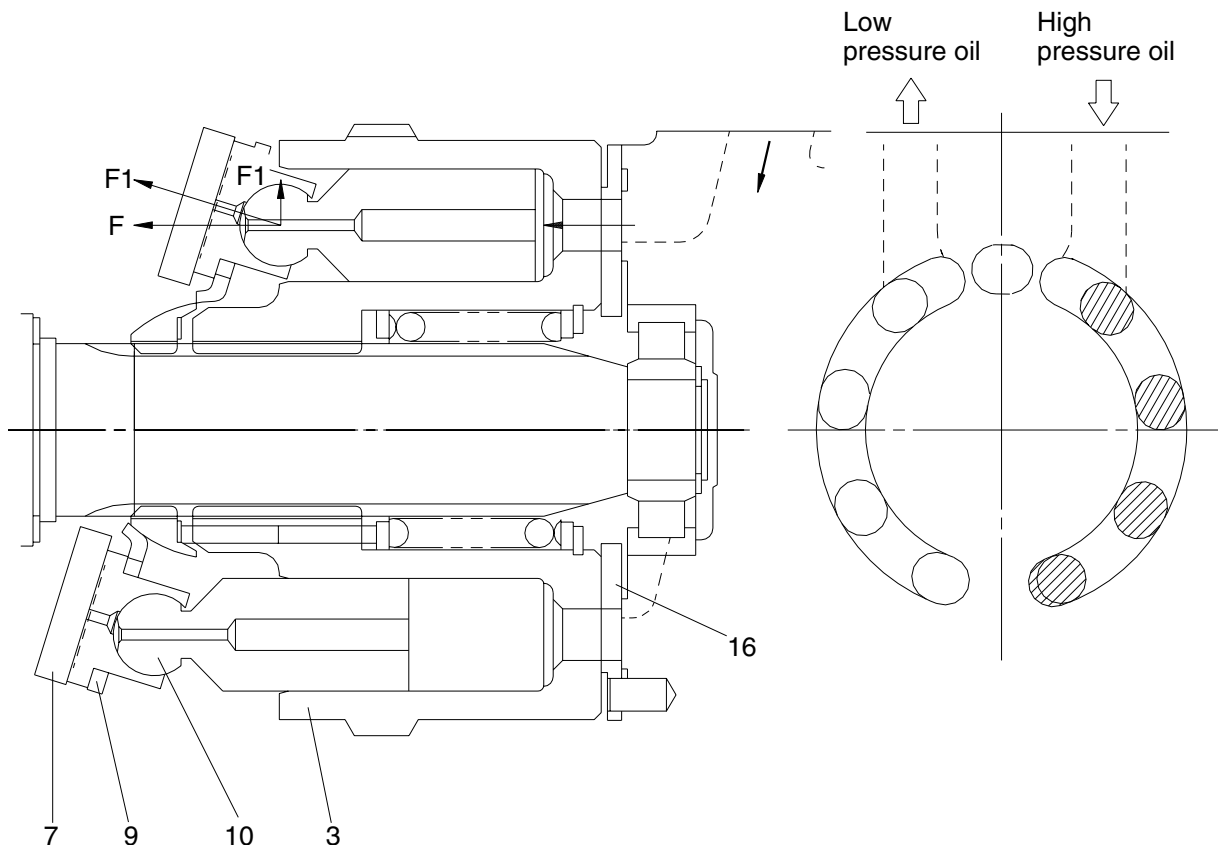

R5572SF35

2) MAKE UP VALVE

(1) Outline

The safety valve portion consists of a check valve and safety valve.

(2) Function

When the swing is stopped, the output circuit of the motor continues to rotate because of inertia. For this reason, the pressure at the output side of the motor becomes abnormally high, and this will damage the motor. To prevent this, the oil causing the abnormal hydraulic pressure is allowed to escape from the outlet port (high-pressure side) of the motor to port **Mu**, thereby preventing damage to the motor.

Compared with a counterbalance valve, there is no closed-in pressure generated at the outlet port side when slowing down the swing speed. This means that there is no vibration when slowing down, so the ease of swing control is improved.

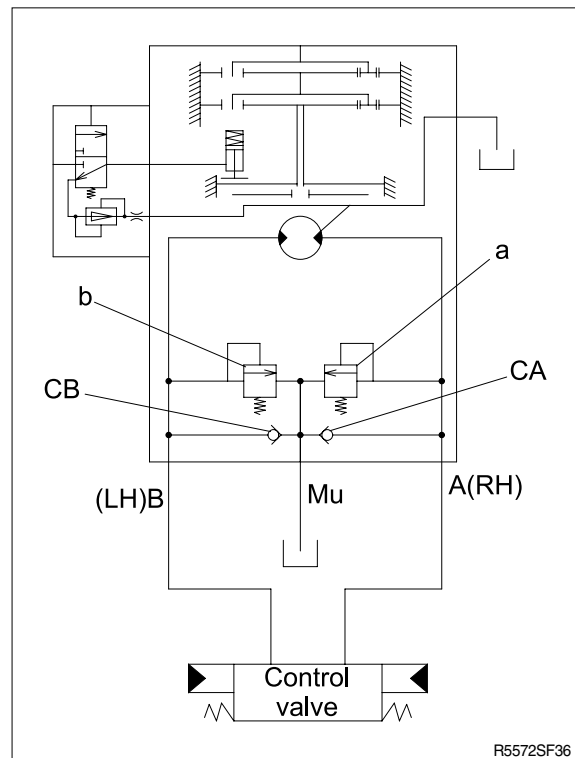

R5572SF36

(3) Operation

① When starting swing

When the swing control lever is operated to left swing, the pressurized oil from the pump passes through the control valves and is supplied to port **B**. Because of this, the pressure at port **B** rises, starting torque is generated in the motor, and the motor starts to rotate. The oil from the outlet port of the motor passes from port **A** through the control valve and returns to the tank.

② **When stopping swing**

- When the swing control lever is returned to neutral, no pressurized oil is supplied from the pump to port **B**.
The return circuit to the tank is closed by the control valve. So the oil from the outlet port of the motor increases in pressure at port **A**. Resistance to the rotation of the motor is created, and the brake starts to act.
- The pressure at port **A** rises to the set pressure of make up valve **a**, and in this way, a high brake torque acts on the motor, and the motor stops.
- When make up valve **a** is being actuated, the relief oil from make up valve **a** and the oil from port **Mu** pass through check valve **CB** and are supplied to port **B**. This prevents cavitation from forming at port **B**.

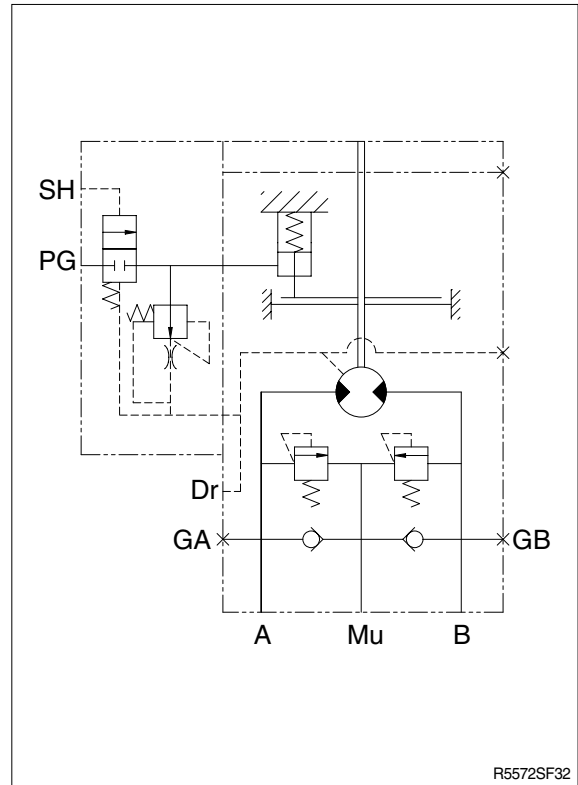

3) RELIEF VALVE

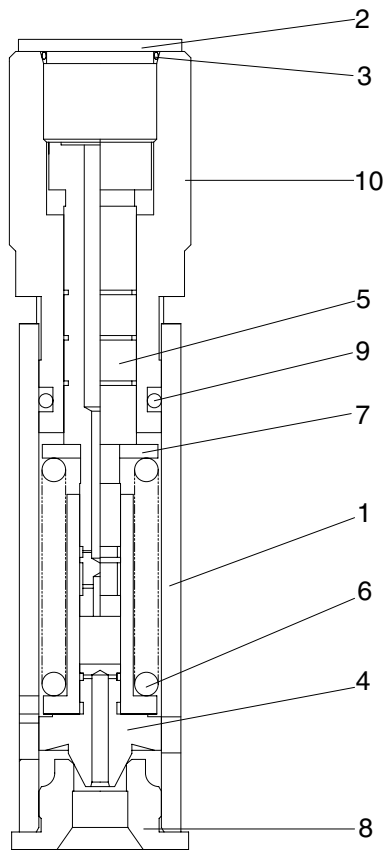

- 1 Body
- 2 Plug
- 3 O-ring
- 4 Plunger
- 5 Piston
- 6 Spring
- 7 Spring seat
- 8 Seat
- 9 O-ring
- 10 Nut

R5572SF37

(1) Construction of relief valve

The valve casing contains two cartridge type relief valves that stop the regular and reverse rotations of the hydraulic motor. The relief valves relieve high pressure at start or at stop of swing motion and can control the relief pressure in two steps, high and low, in order to insure smooth operation.

(2) Function of relief valve

Figure illustrates how the pressure acting on the relief valve is related to its rising process. Here is given the function, referring to the figure following page.

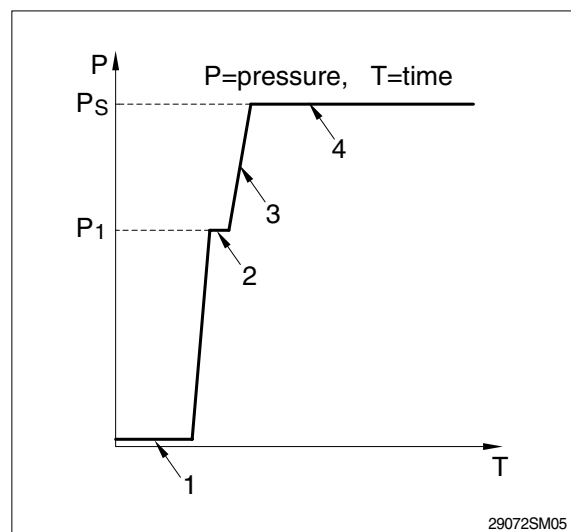

4) BRAKE SYSTEM

(1) Control valve swing brake system

This is the brake system to stop the swing motion of the excavator during operation.

In this system, the hydraulic circuit is throttled by the swing control valve, and the resistance created by this throttling works as a brake force to slow down the swing motion.

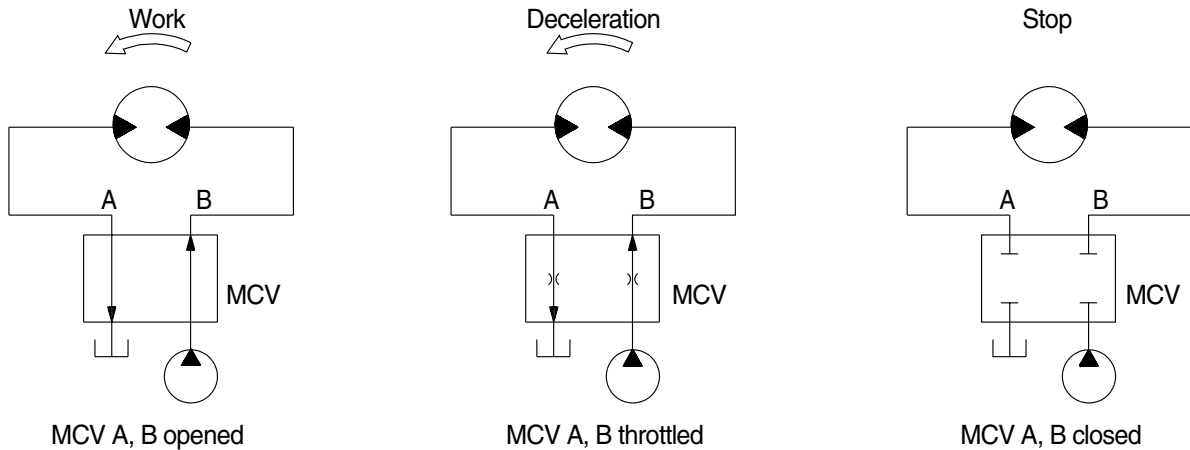

210-7 2-48(1)

(2) Mechanical swing parking brake system

The mechanical swing parking brake system is installed to prevent the upper structure from swinging downhill because of its own weight when the excavator is parked on a slope since it completely eliminates the hydraulic drift of swing motion while the excavator is on a slope, work can be done more easily and safely.

① Brake assembly

Circumferential rotation of separate plate(27) is constrained by the groove located at casing(1). When housing is pressed down by brake spring(30) through friction plate(26), separate plate(27) and brake piston(28), friction force occurs there.

Cylinder(3) is constrained by this friction force and brake acts, while brake releases when hydraulic force exceeds spring force.

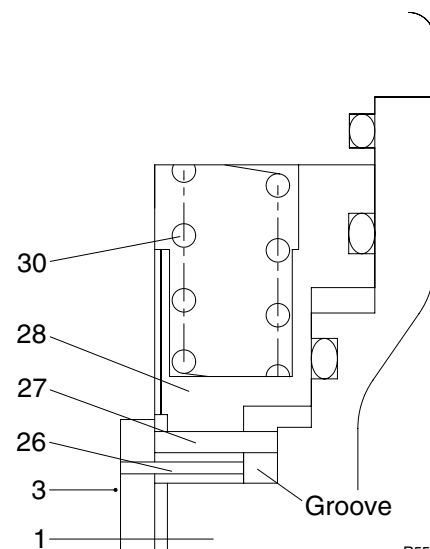

R5572SF38

1	Casing	27	Separate plate
3	Cylinder	28	Brake piston
26	Friction plate	30	Brake spring

② **Operating principle**

- a. When the swing control lever(1) is set to the swing position, the pilot oil go to the swing control valve(2) and to SH of the time delay valve(3) via the shuttle valve(4), this pressure move spool(5) to the leftward against the force of the spring(8), so pilot pump charged oil(P4) goes to the chamber G.

This pressure is applied to move the piston(28) to the upward against the force of the spring(30). Thus, it releases the brake force.

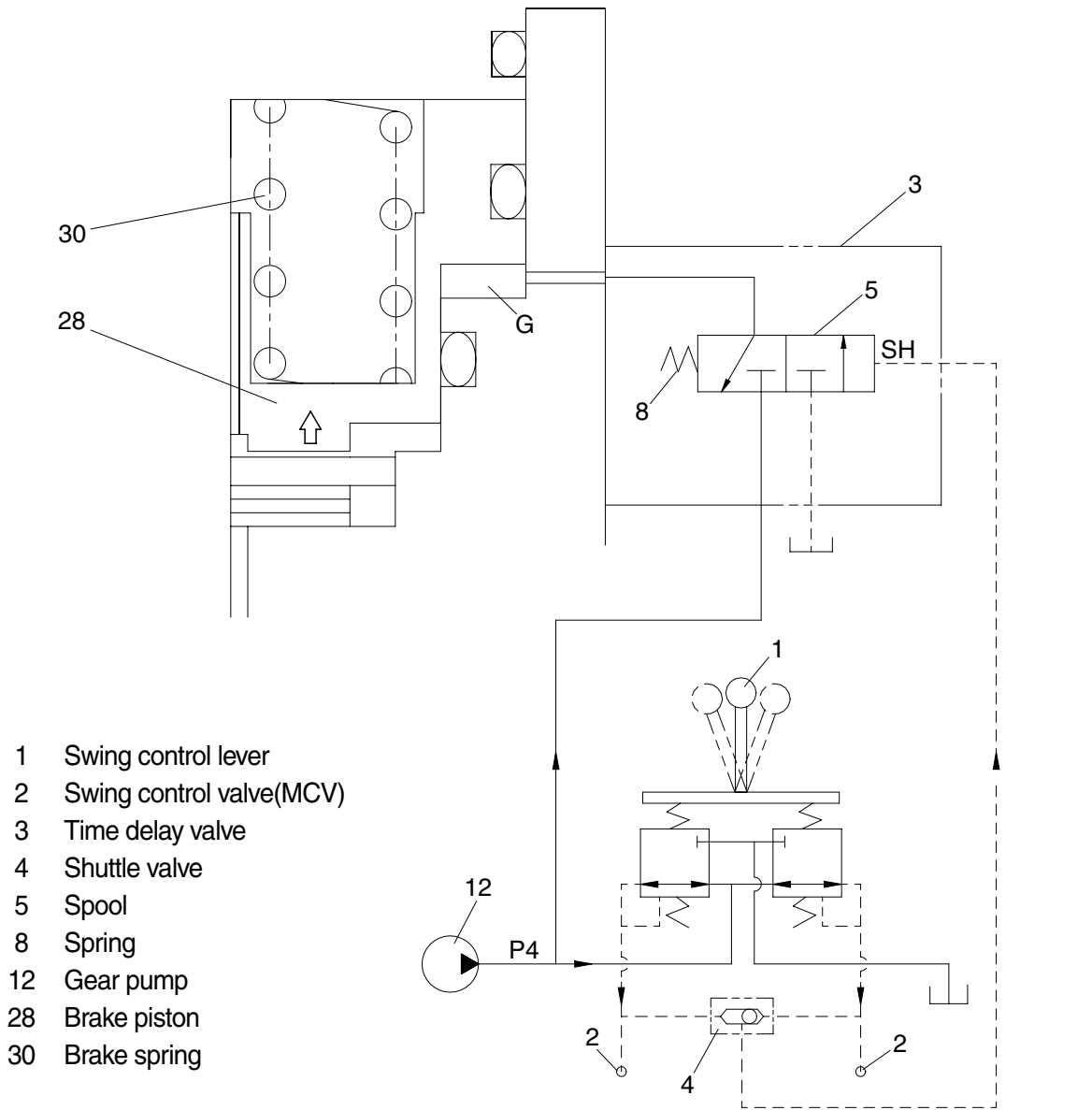

R5572SF39

- b. When the swing control lever(1) is set the neutral position, the time delay valve(3) shifts the neutral position and the pilot oil blocked chamber G. Then, the piston(28) is moved lower by spring(30) force and the return oil from the chamber G is drain.

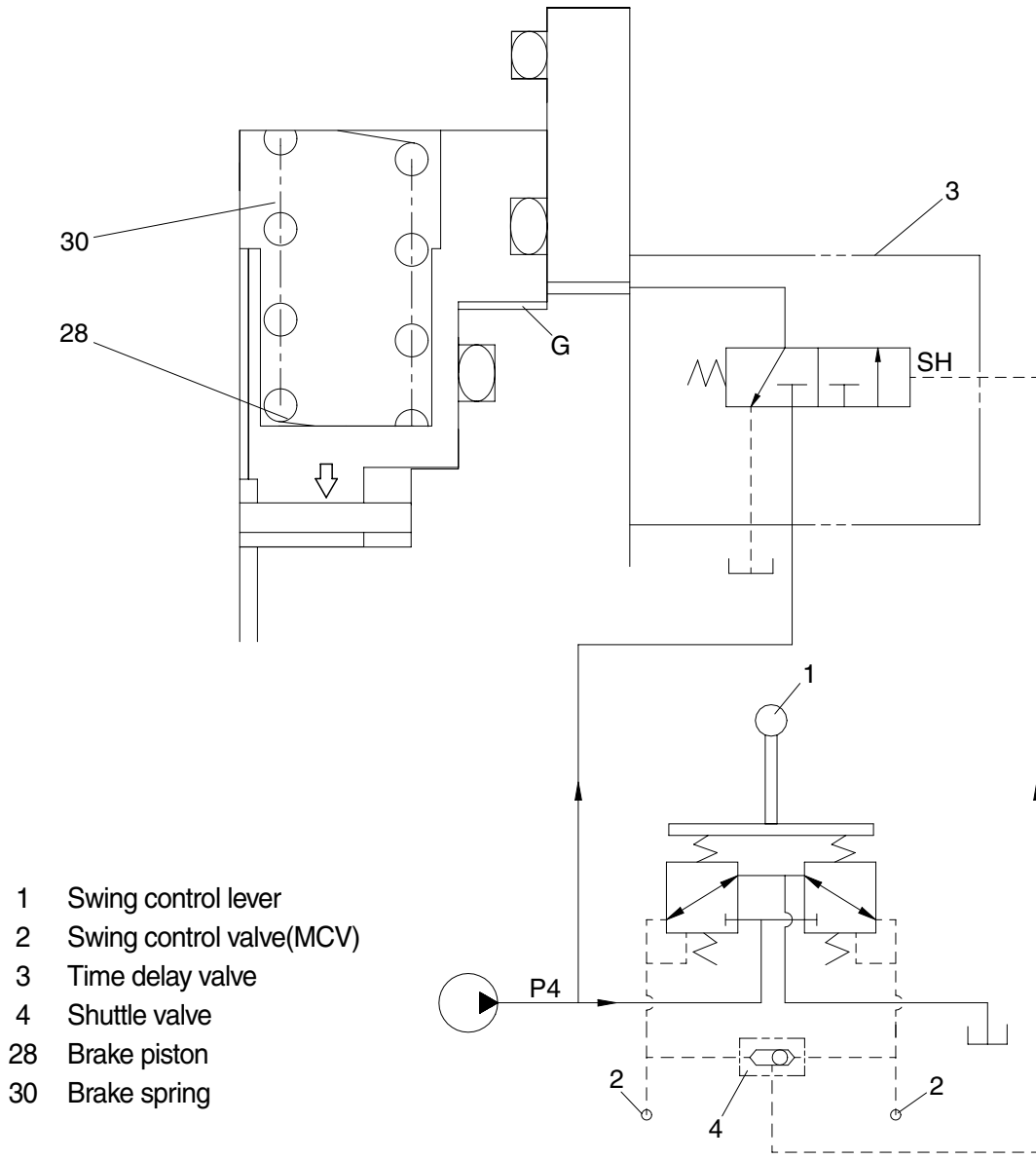

R5572SF40