

GROUP 2 MAIN CONTROL VALVE

1. OUTLINE

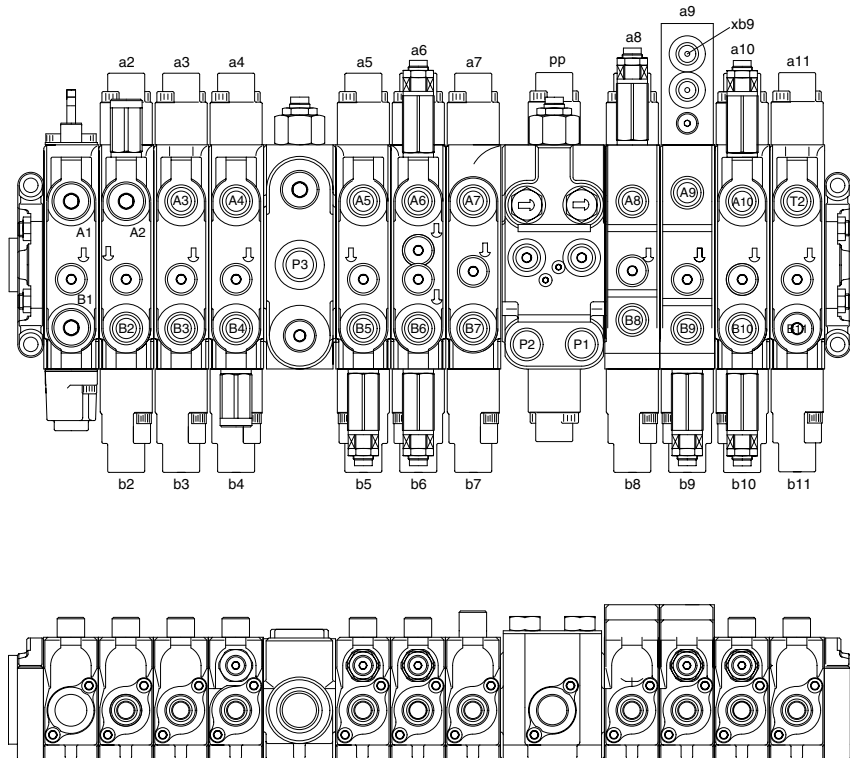

55W72MC01

Mark	Port name	Port size	Tightening torque	Mark	Port name	Port size	Tightening torque		
P1	P1 pump port	PF 1/2	6.0~7.0 kgf · m	A10	Bucket out port	PF 1/2	6.0~7.0 kgf · m		
P2	P2 pump port			B10	Bucket in port				
P3	P3 pump port			B11	Arm 2 port				
A1	Option port			PF 1/4	2.5~3.0 kgf · m	T2	Tank return port	PF1	10~12kgf · m
B1	Option port					T1	Tank return port		
A2	Boom swing(RH) port					a2	Boom swing (RH) pilot port	PF 1/4	2.5~3.0 kgf · m
B2	Boom swing(LH) port					b2	Boom swing (LH) pilot port		
A3	Swing (LH) port					a3	Swing (RH) pilot port		
B3	Swing (RH) port					b3	Swing (RH) pilot port		
A4	Dozer down port	a4	Dozer down pilot port						
B4	Dozer up port	b4	Dozer up pilot port						
A5	Boom 2 port	a5	Boom 2 pilot port						
B5	Breaker port	b5	Breaker pilot port						
A6	Arm out port	a6	Arm out pilot port						
B6	Arm in port	b6	Arm in pilot port						
A7	Travel [LH/FW] port	a9	Boom up pilot port	PF 1/4	2.5~3.0 kgf · m				
B7	Travel [LH/RR] port	b9	Boom down pilot port						
A8	Travel [RH/FW] port	a10	Bucket out pilot port						
B8	Travel [RH/RR] port	b10	Bucket in pilot port						
A9	Boom up port	a11	Arm 2 pilot port						
B9	Boom down port	b11	Arm 2 pilot port						

2. STRUCTURE(1/4)

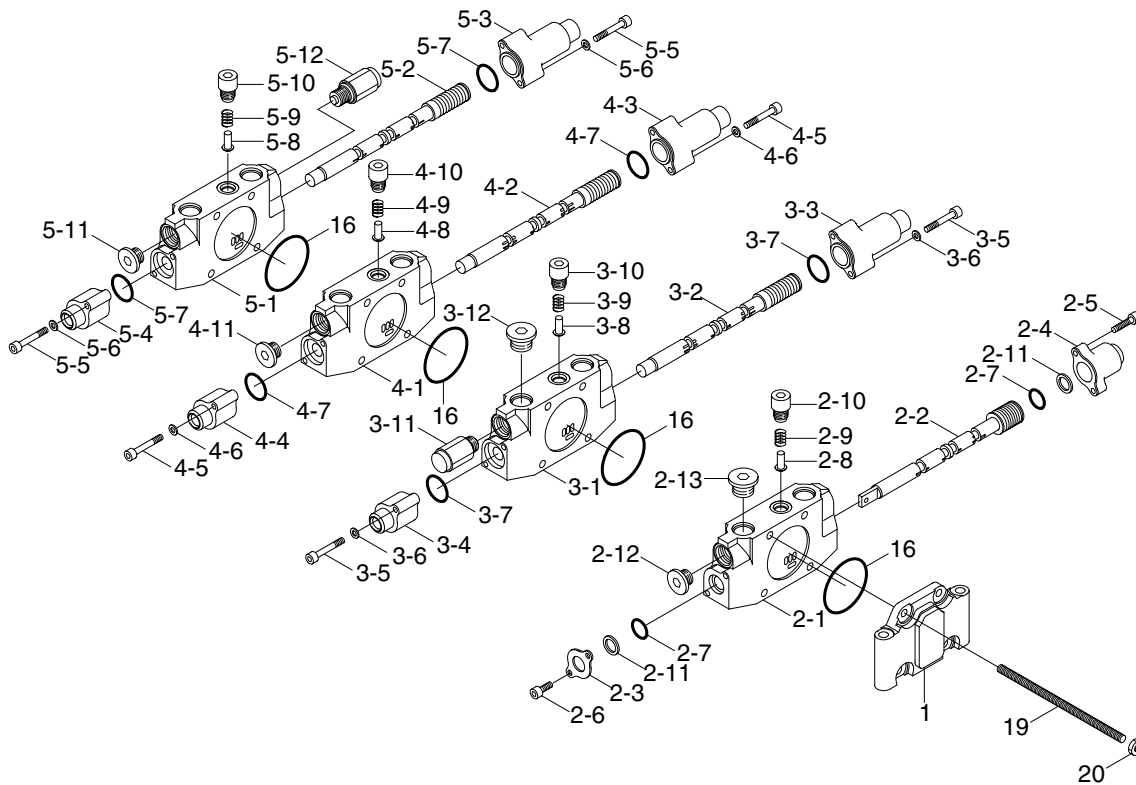

55W72MC02

1	End cover	3-4	Pilot cap(B1)	4-10	Plug assy
2	Option block	3-5	Wrench bolt	4-11	Plug assy
2-1	Work block assy	3-6	Plain washer	5	Dozer block assy
2-2	Option spool assy	3-7	O-ring	5-1	Work block
2-3	Seal plate	3-8	Check poppet	5-2	Dozer spool assy
2-4	Return cap	3-9	Check spring	5-3	Pilot cap(A)
2-5	Wrench bolt	3-10	Plug assy	5-4	Pilot cap(B1)
2-6	Wrench bolt	3-11	Anti cavitation valve	5-5	Wrench bolt
2-7	O-ring	3-12	Plug assy	5-6	Plain washer
2-8	Check poppet	4	Swing block assy	5-7	O-ring
2-9	Check spring	4-1	Work block	5-8	Check poppet
2-10	Plug assy	4-2	Swing spool assy	5-9	Check spring
2-11	Dust wiper	4-3	Pilot cap(A)	5-10	Plug assy
2-12	Plug assy	4-4	Pilot cap(B1)	5-11	Plug assy
2-13	Plug assy	4-5	Wrench bolt	5-12	Anti-cavitation valve
3	Boom swing block assy	4-6	Plain washer	16	O-ring
3-1	Work block	4-7	O-ring	19	Tie bolt
3-2	Boom swing spool assy	4-8	Check poppet	20	Nut
3-3	Pilot cap(A)	4-9	Check spring		

STRUCTURE(2/4)

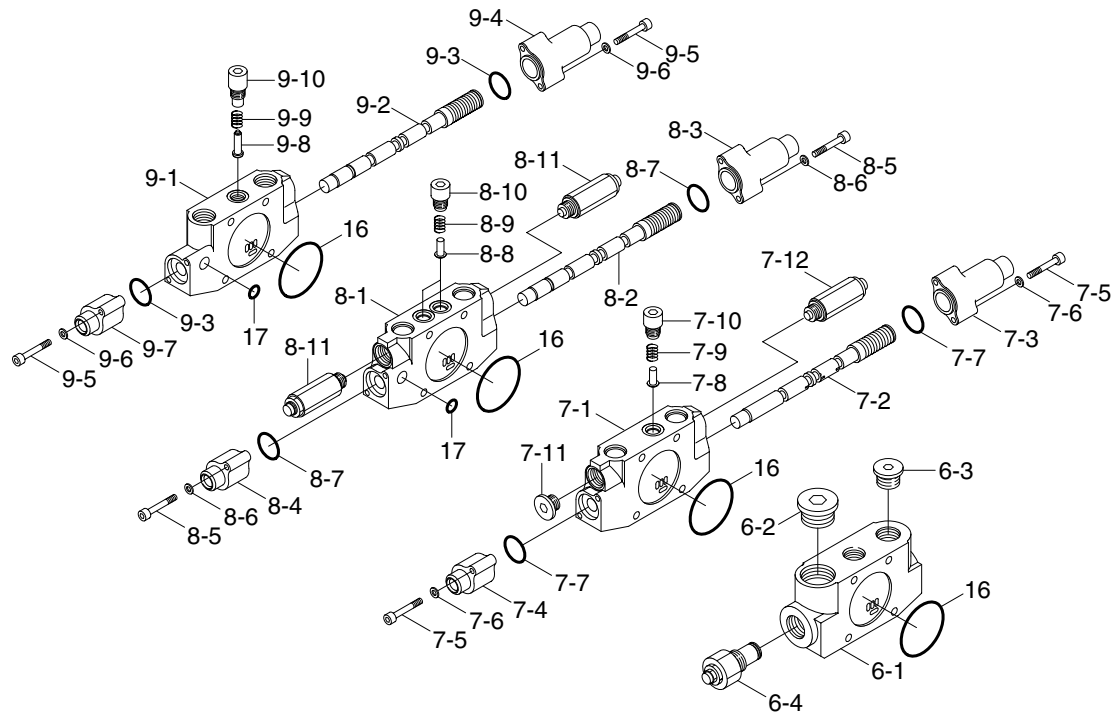

55W72MC03

6	Inlet block assy	7-10	Plug Assy	9	Travel block assy
6-1	Work block	7-11	Plug Assy	9-1	Work block
6-2	Plug Assy	7-12	Overload relief valve	9-2	Travel spool assy
6-3	Plug Assy	8	Arm 1 block assy	9-3	O-ring
6-4	Main relief valve	8-1	Work block	9-4	Pilot cap(A)
7	Boom 2 block assy	8-2	Arm 1 spool assy	9-5	Wrench bolt
7-1	Work block	8-3	Pilot cap(A)	9-6	Plain washer
7-2	Boom 2 spool assy	8-4	Pilot cap(B1)	9-7	Pilot cap(B1)
7-3	Pilot cap(A)	8-5	Wrench bolt	9-8	Check poppet
7-4	Pilot cap(B1)	8-6	Plain washer	9-9	Check spring
7-5	Wrench bolt	8-7	O-ring	9-10	Plug 2 Assy
7-6	Plain washer	8-8	Check poppet	16	O-ring
7-7	O-ring	8-9	Check spring	17	O-ring
7-8	Check poppet	8-10	Plug Assy		
7-9	Check spring	8-11	Overload relief valve		

STRUCTURE(3/4)

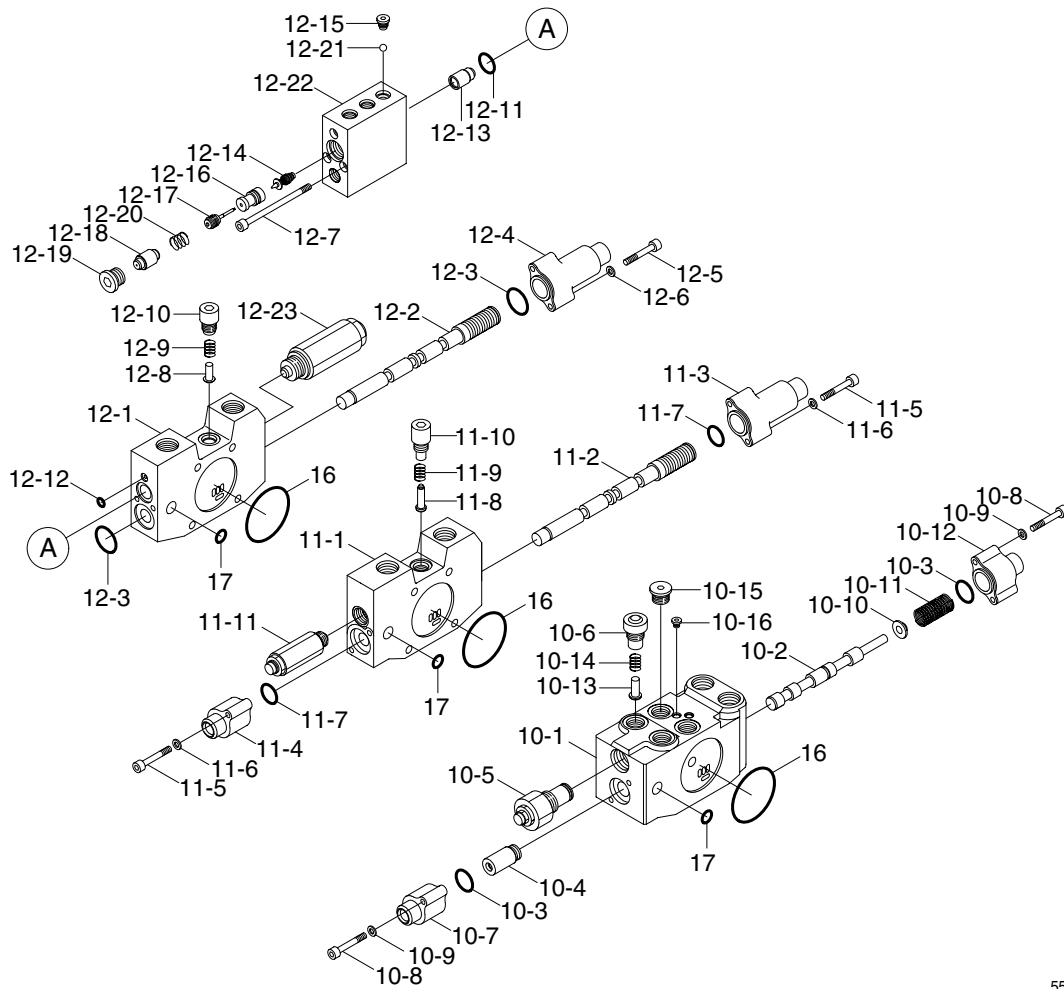

55W72MC04

10	Inlet block assy	11-2	Travel spool assy	12-8	Check poppet
10-1	Work block	11-3	Pilot cap(A)	12-9	Check spring
10-2	Travel straight spool assy	11-4	Pilot cap(B1)	12-10	Plug assy
10-3	O-ring	11-5	Wrench bolt	12-11	O-ring
10-4	Filter assy	11-6	Plain washer	12-12	O-ring
10-5	Main relief valve	11-7	O-ring	12-13	Holding poppet assy
10-6	Plug 3 assy	11-8	Check poppet	12-14	Pilot poppet
10-7	Pilot cap(B1)	11-9	Check spring	12-15	Plug assy
10-8	Wrench bolt	11-10	Plug 2 assy	12-16	Piston guide assy
10-9	Plain washer	11-11	Overload relief valve	12-17	Piston
10-10	Spring seat	12	Boom 1 block assy	12-18	Pilot piston
10-11	Pilot spring	12-1	Work block	12-19	Plug assy
10-12	Pilot cap(B2)	12-2	Boom 1 spool assy	12-20	Spring
10-13	Check poppet	12-3	O-ring	12-21	Steel ball
10-14	Check spring	12-4	Pilot cap(A)	12-22	Pilot cover
10-15	Plug assy	12-5	Wrench bolt	12-23	Overload relief valve
10-16	Wrench bolt	12-6	Plain washer	16	O-ring
11	Travel block assy	12-7	Wrench bolt	17	O-ring
11-1	Work block				

STRUCTURE(4/4)

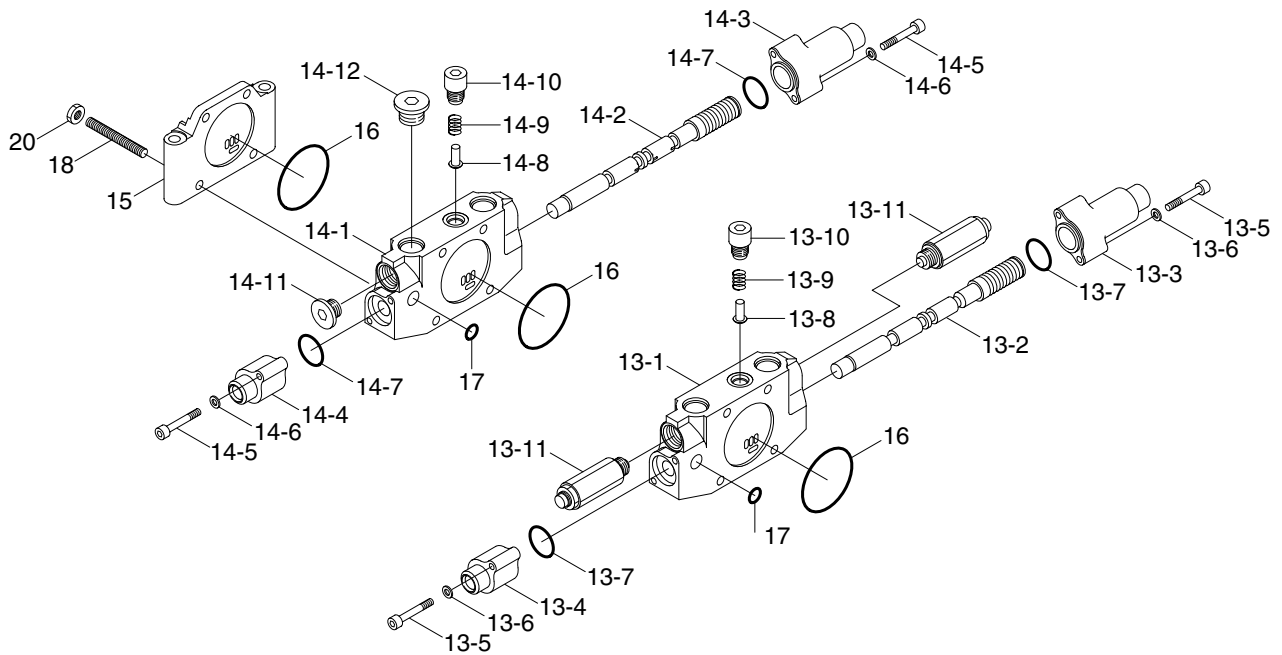

55W72MC05

13	Bucket block assy	13-10	Plug assy	14-8	Check poppet
13-1	Work block	13-11	Overload relief valve	14-9	Check spring
13-2	Bucket spool assy	14	Arm 2 block assy	14-10	Plug assy
13-3	Pilot cap(A)	14-1	Work block	14-11	Plug assy
13-4	Pilot cap(B1)	14-2	Arm 2 spool assy	14-12	Plug assy
13-5	Wrench bolt	14-3	Pilot cap(A)	15	End cover
13-6	Plain washer	14-4	Pilot cap(B1)	16	O-ring
13-7	O-ring	14-5	Wrench bolt	17	O-ring
13-8	Check poppet	14-6	Plain washer	18	Tie bolt
13-9	Check spring	14-7	O-ring	20	Nut

3. HYDRAULIC CIRCUIT

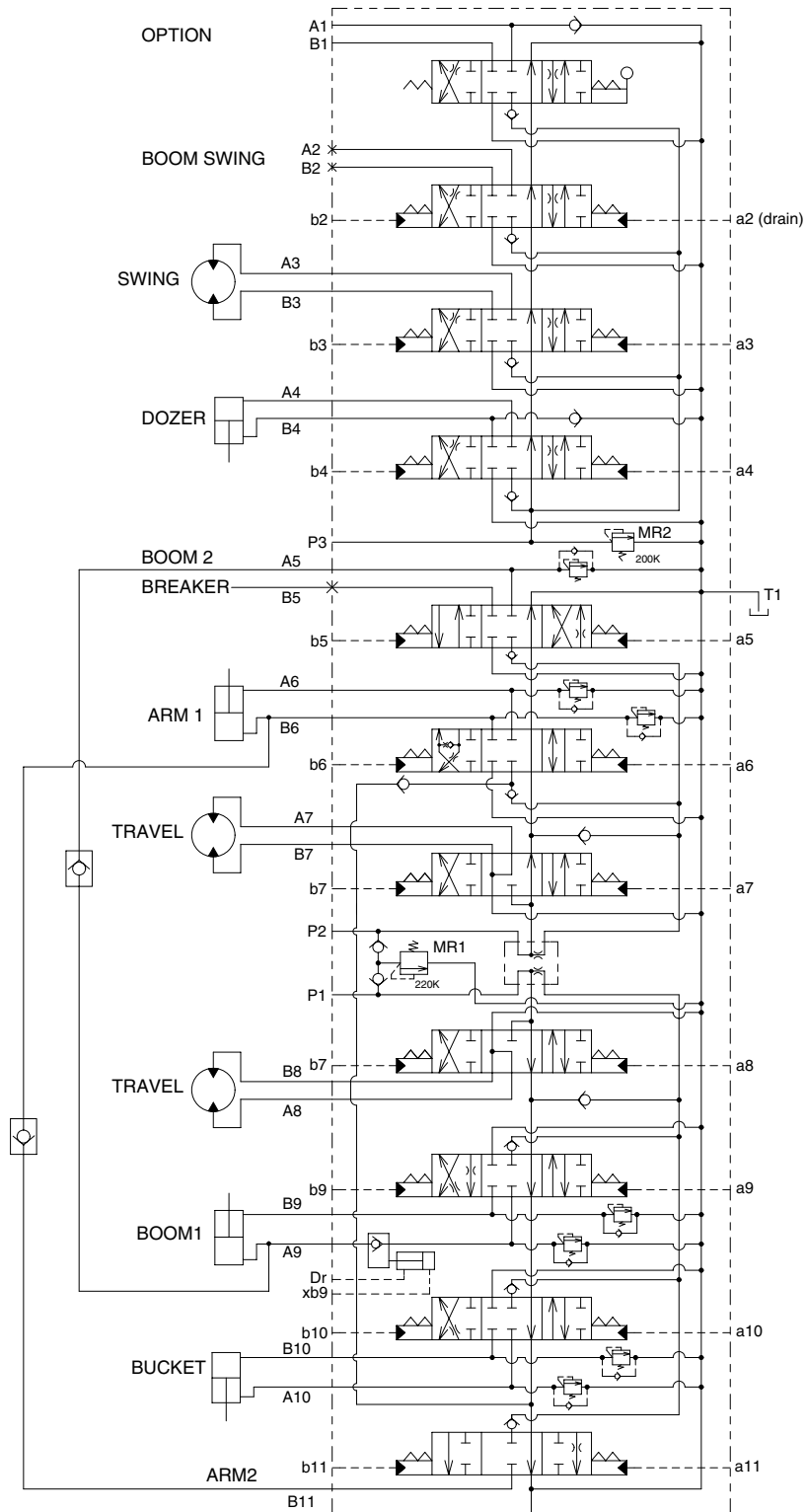

4. FUNCTION

1) CONTROL IN NEUTRAL FUNCTION

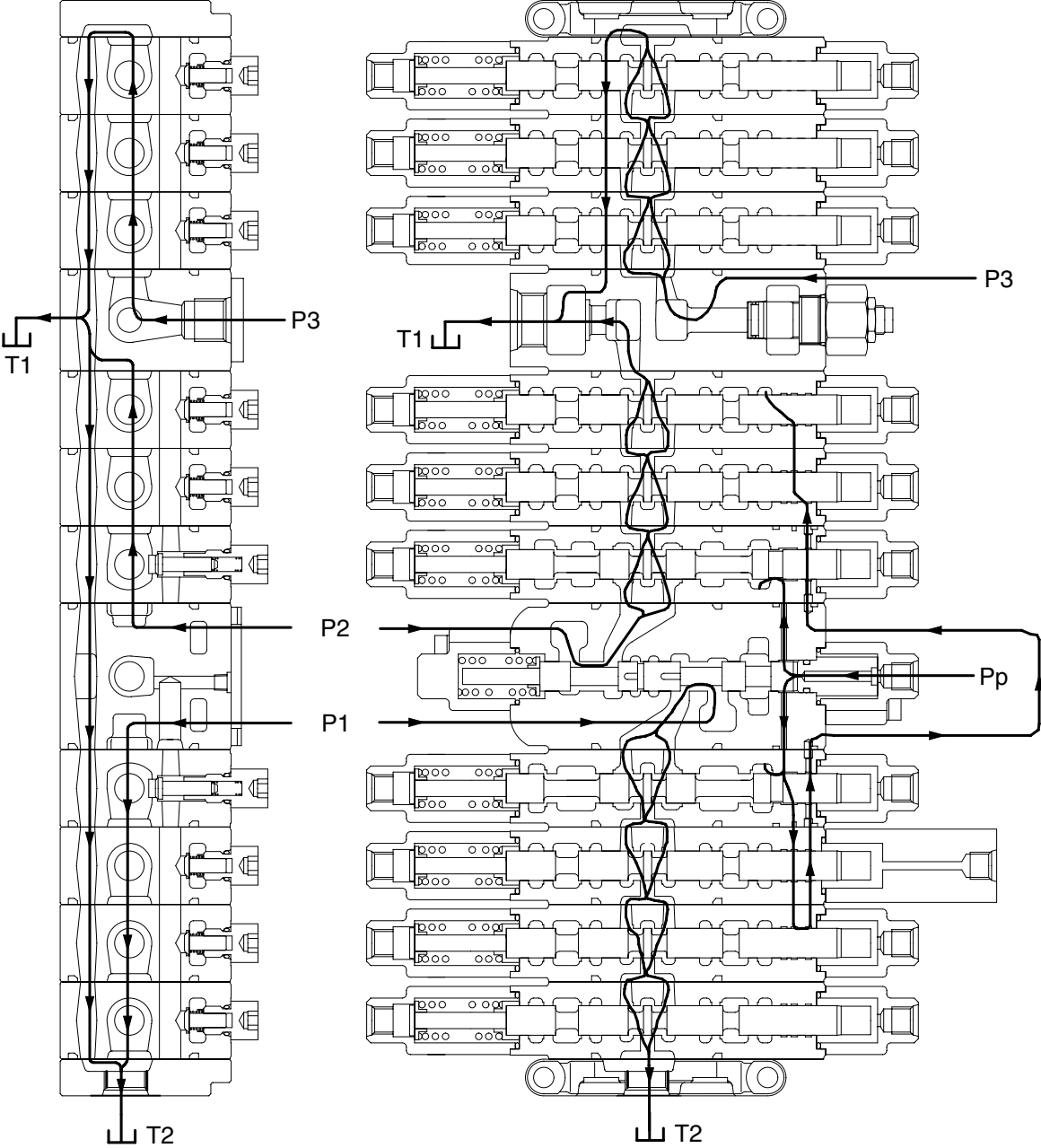

55W72MC07

In neutral, spring sets the spool at the neutral position, the hydraulic oil from pumps flow to the tank through the center bypass.

2) EACH SPOOL OPERATION

(1) TRAVEL OPERATION

① Travel forward operation

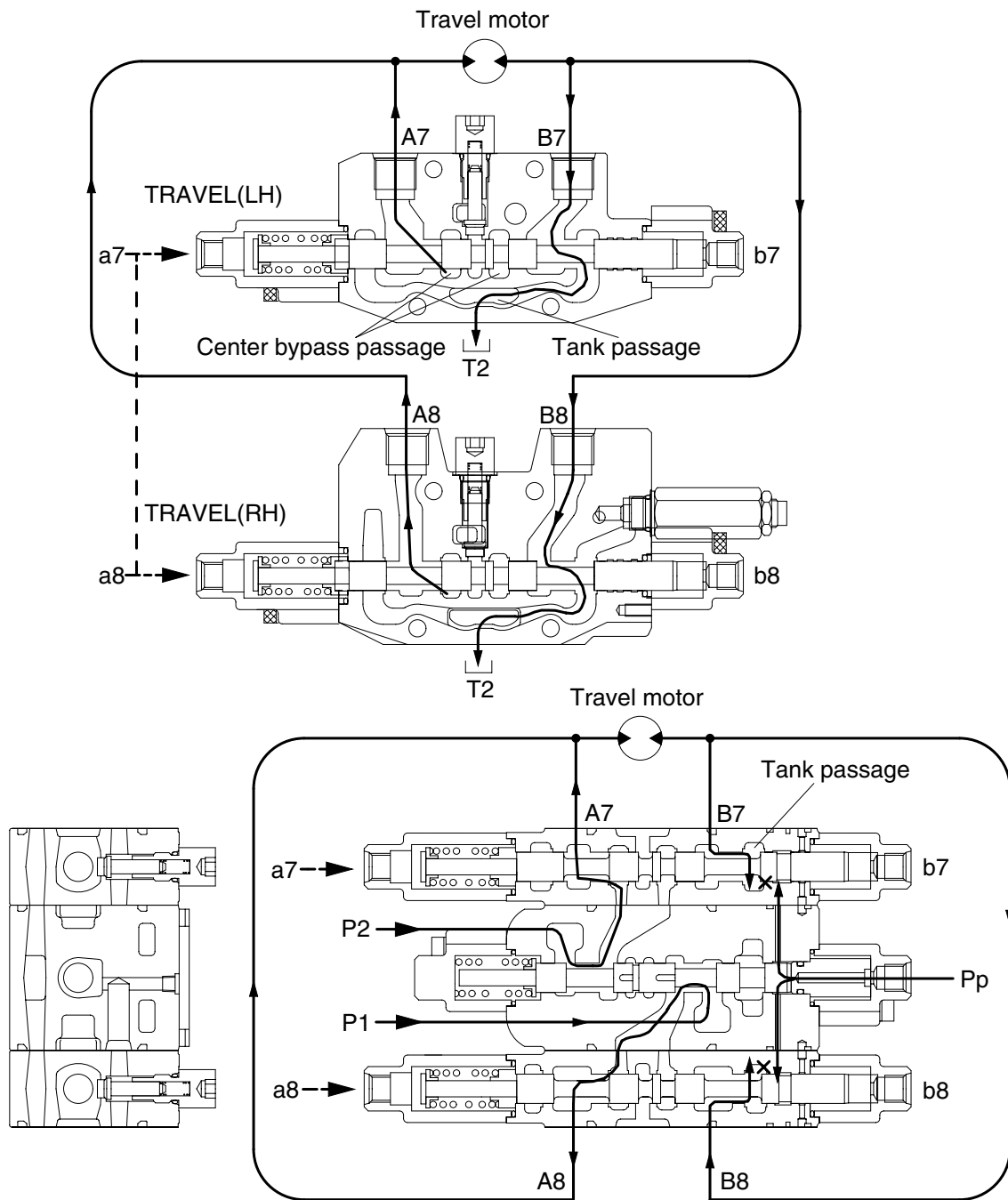

55W72MC08

During the travel operation, the hydraulic fluid of the pump P1, P2 is supplied to the travel motor. The pilot pressure from the solenoid valve is supplied to the left side of pilot ports(a7, a8).

And it shifts travel spools in the right direction against left. Hydraulic fluid from the pump P1, P2 flow into the travel spool through the bypass passage.

Then they are directed to the travel motor through port A7 and A8. As a result, the travel motor turn and hydraulic fluid returns to the tank passage through the travel spools.

② Travel backward operation

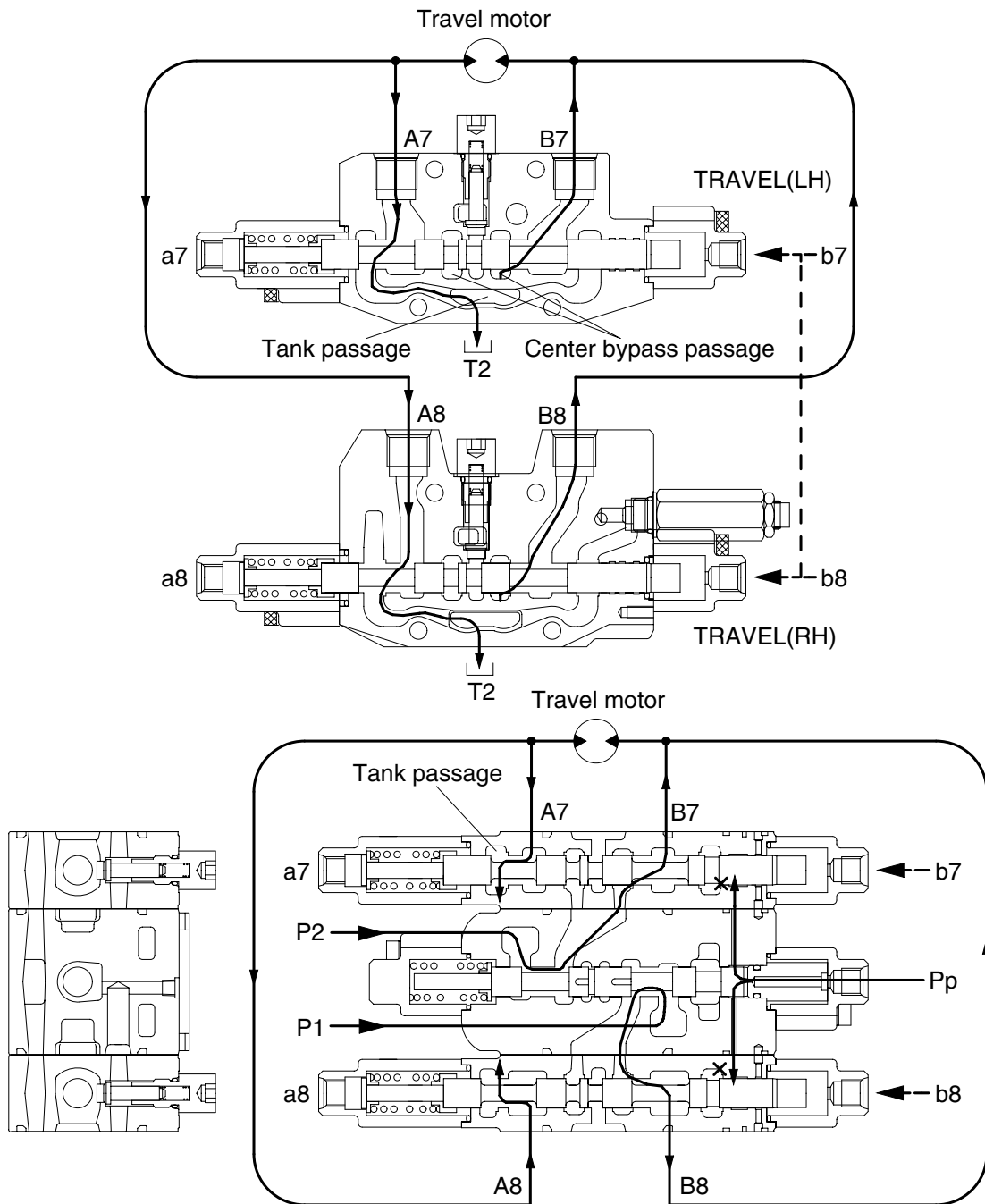

55W72MC09

During the travel operation, the hydraulic fluid of the pump P1, P2 is supplied to the travel motor. The pilot pressure from the solenoid valve is supplied to the right side of pilot ports(b7, b8). And it shifts travel spools in the left direction against springs. Hydraulic fluid from the pump P1, P2 flow into the travel spools through the bypass passage. Then they are directed to the travel motor through port B7 and B8. As a result, the travel motor turn and hydraulic fluid returns to the tank passage through the travel spools.

(3) BOOM OPERATION

① Boom up operation

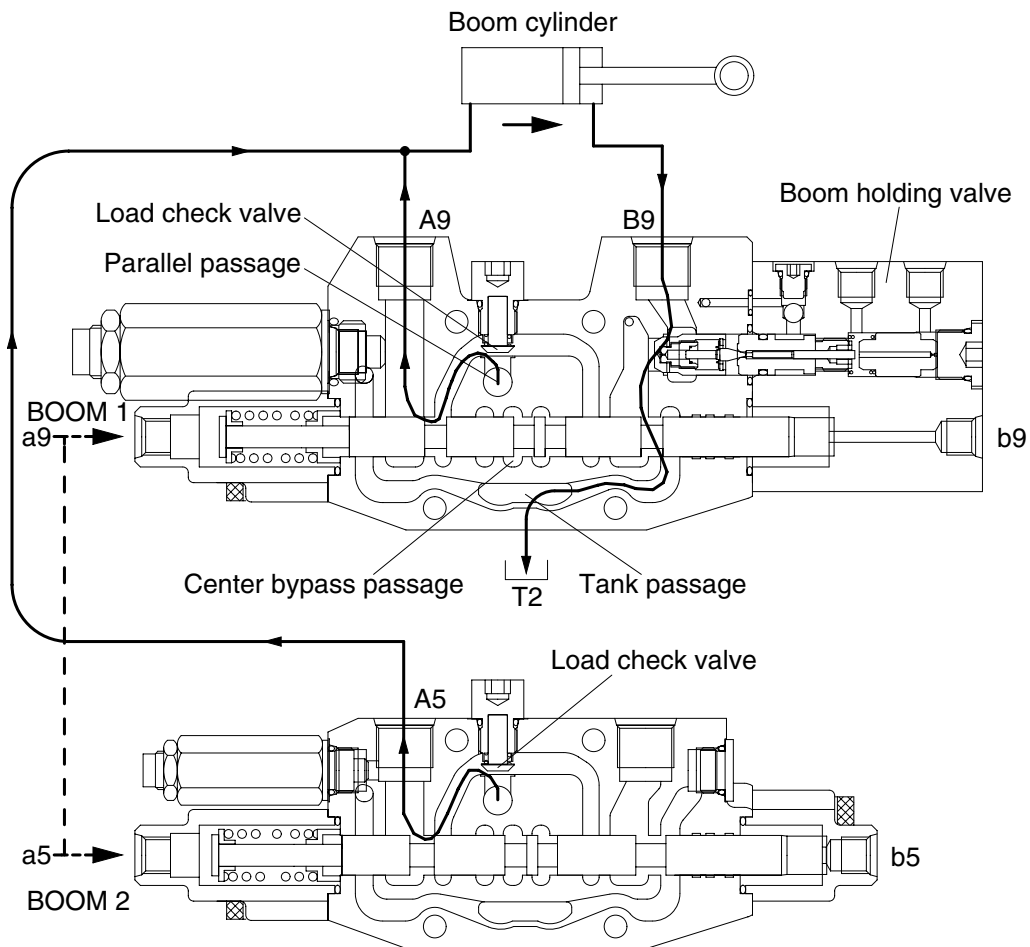

55W72MC10

During boom up operation, the pilot pressure from RCV is supplied into the port a9 and shift the boom1 spool in the right direction. The hydraulic oil fluid from pump P1 is entered P1 parallel passage and then passes through the load check valve then flows into the port A9.

Following this it flows into the head side of the boom cylinder.

At the same time the pilot pressure through the port a5 shifts the boom2 spool. The hydraulic oil fluid from pump P2 is entered P2 parallel passage and then passes through the load check valve then flows into the port A5. The flows combine in hydraulic hoses and are directed to the cylinder head side of boom cylinder.

The flow from rod side of the boom cylinder return to the boom1 spool through the port B9. There after it is directed to the hydraulic oil tank through the tank passage.

② Boom down operation

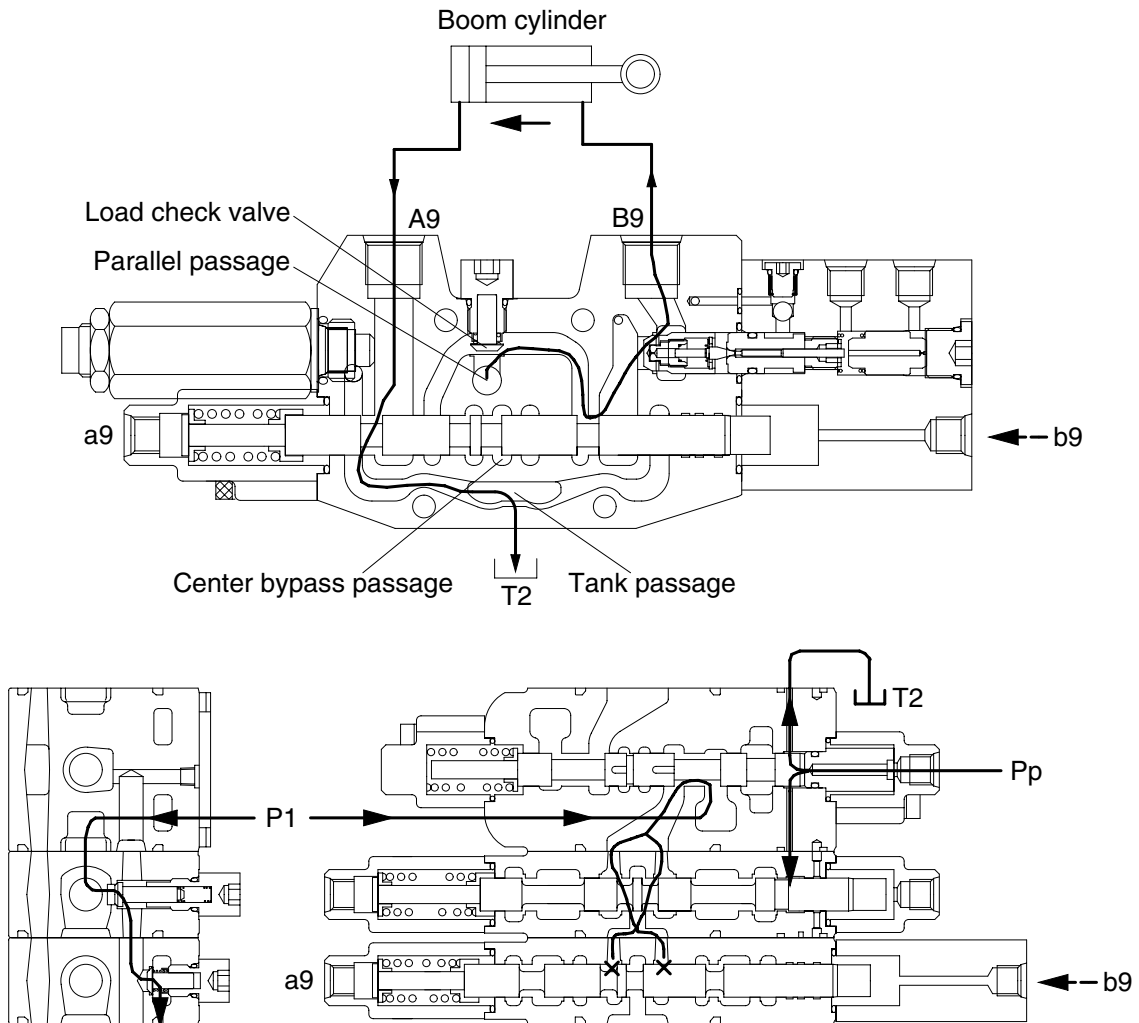

55W72MC11

During the boom lowering operation, the pilot pressure from RCV is supplied to the port b9 and shift the boom1 spool in the left direction.

The hydraulic fluid from the pump P1 enters the parallel passage and is directed to the port B9 through the load check valve. Following this, it flows into the rod side of the boom cylinder.

The return flow from the head side of the boom cylinder returns to the boom1 spool through the port A9. Thereafter it is directed to the hydraulic oil tank through tank passage.

(4) BUCKET OPERATION

• Bucket roll in operation

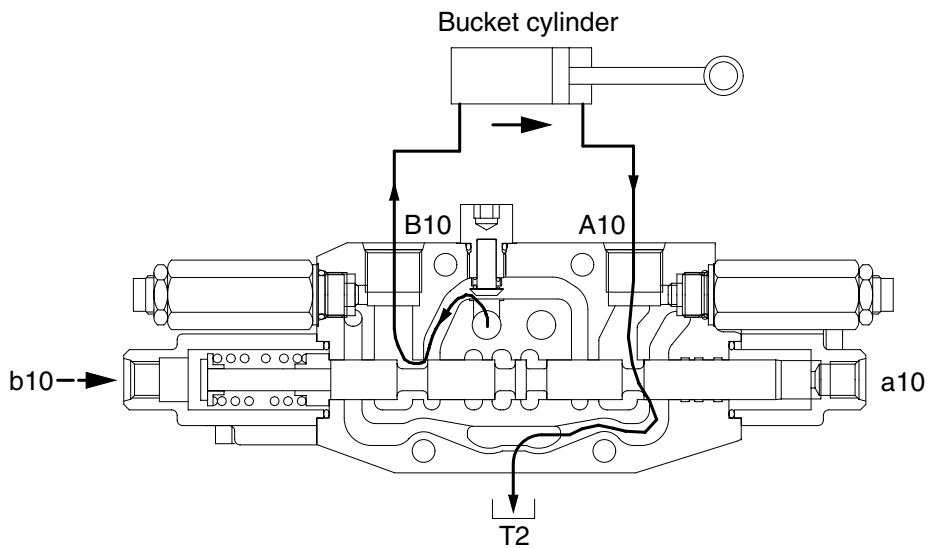

• Bucket roll out operation

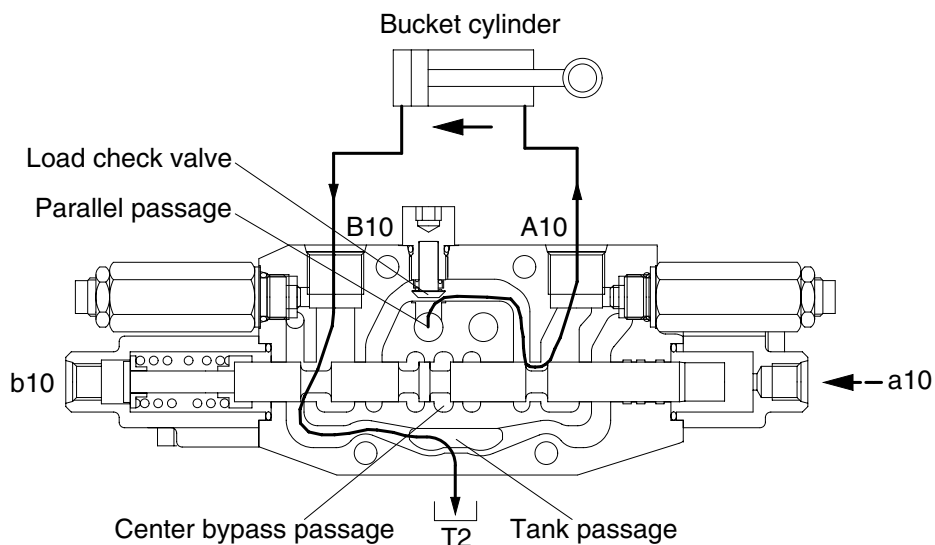

55W72MC12

① Bucket roll in operation

During the bucket roll in operation, the pilot pressure from RCV is supplied to port b10 and shift the bucket spool in the right direction.

The hydraulic fluid from pump P1 entered P1 parallel passage and is directed to the port B10 through the load check valve.

Following this it flows into the head side of the bucket cylinder.

The return flow from the rod side of the bucket cylinder returns to the bucket spool through the port A10. Thereafter it is directed to the hydraulic oil tank through the tank passage.

② Bucket roll out operation

In case of the bucket roll out operation, the operation is similar.

(5) SWING OPERATION

① Swing right operation

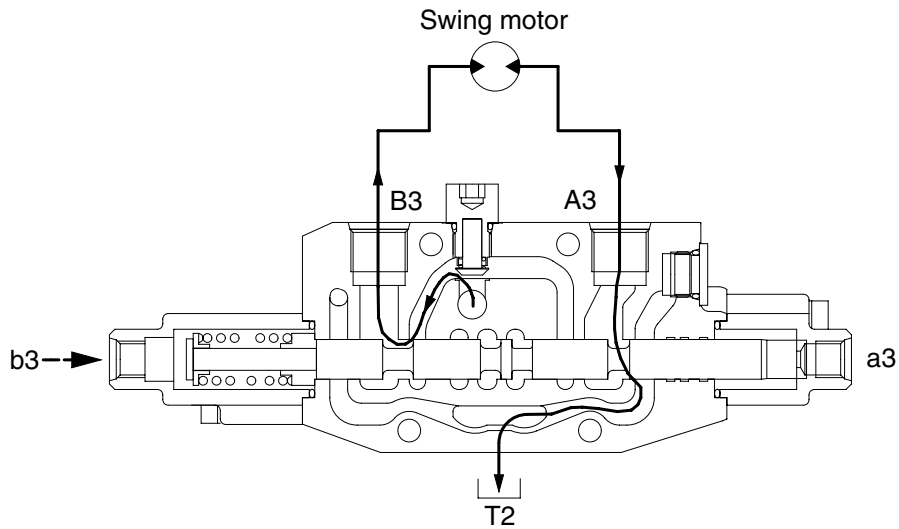

55W72MC13

② Swing left operation

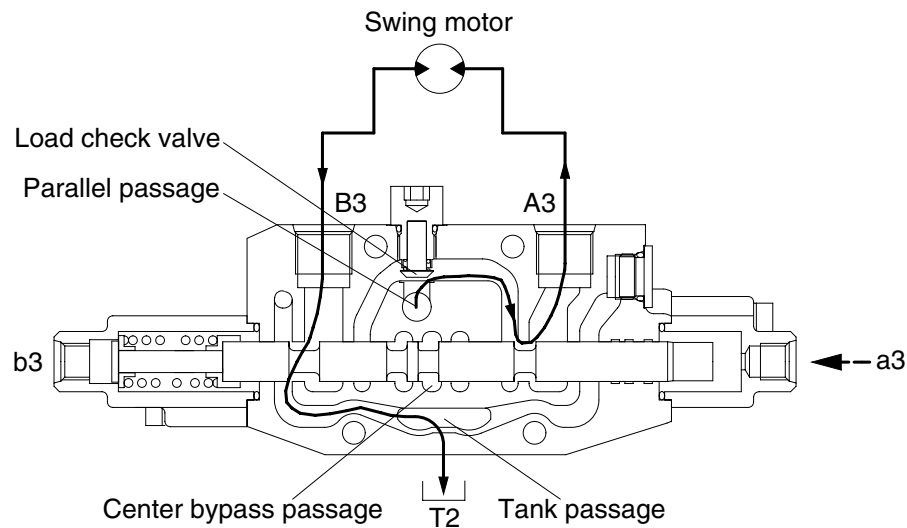

55W72MC13

The pilot pressure from the RCV is supplied to the b3 and shift the swing spool in right direction. The hydraulic fluid from pump P3 flows into swing spool through the parallel passage. Then it is directed to swing motor through the port B3. As the result, swing motor turns and flow from the swing motor returns to the hydraulic oil tank through the port A3, swing spool and the tank passage .

In case of swing left operation, the operation is similar.

(6) ARM OPERATION

① Arm roll in operation

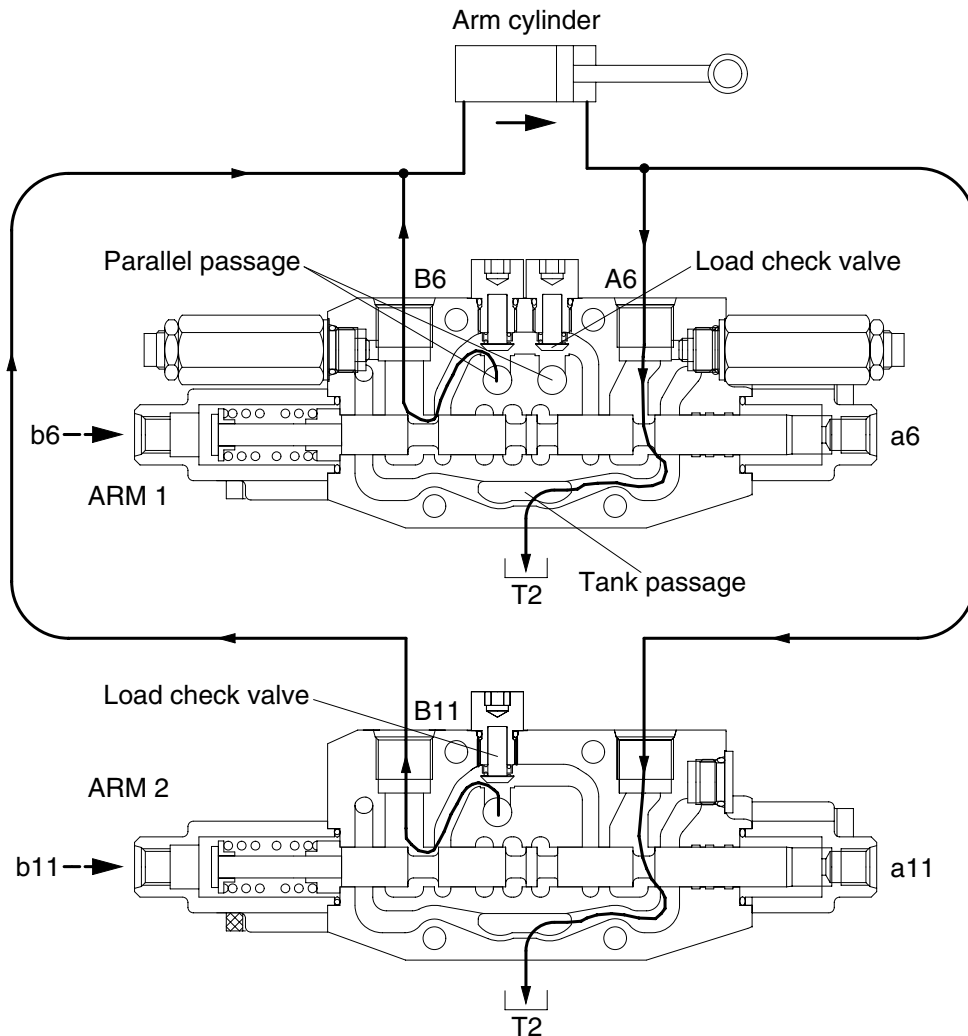

55W72MC14

During arm roll in operation the pilot pressure from the RCV is supplied to the port b6 and b11 and shifts arm1 spool and arm2 spool in the right direction.

The hydraulic oil from the pump P2 flows into the arm cylinder head side through P2 parallel passage, the load check valve and the port B6.

At same time, the hydraulic fluid from the pump P1 flows into the arm summation passage in arm1 spool through the arm2 spool. Then it entered the arm cylinder head side with hydraulic fluid from

② Arm roll out operation

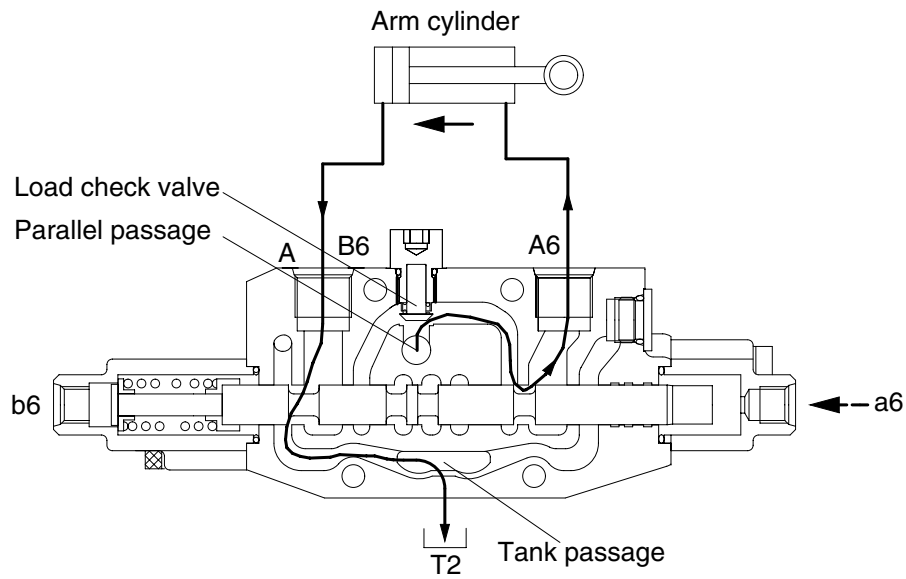

55W72MC15

During arm roll out operation the pilot pressure from RCV is supplied to the port a6 and shifts arm1 spool in the left direction.

The hydraulic fluid from pump P2 flows into arm1 spool through the parallel passage. Then it enters into the arm cylinder rod side through the load check valve and the port A6.

The return flow from the arm cylinder head side returns to the hydraulic tank through the port B6 the arm1 spool and tank passage.

(7) HOLDING VALVE OPERATION

① Holding operation

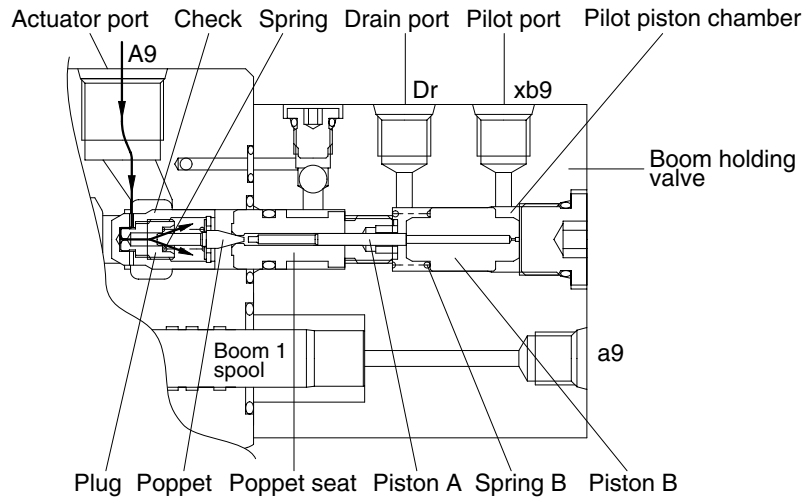

55W72MC16

At neutral condition, the pilot piston chamber is connected to drain port through the pilot port. And the piston "B" is supported with spring "B" and the pressured fluid from actuator entered to inside of the holding valve through the periphery hole of check, crevice of the check and the plug and the periphery hole of plug.

Then, this pressured oil pushed the poppet to the poppet seat and the check to the seat of body. So the hydraulic fluid from actuator is not escaped and the actuator is not moved.

② Release holding operation

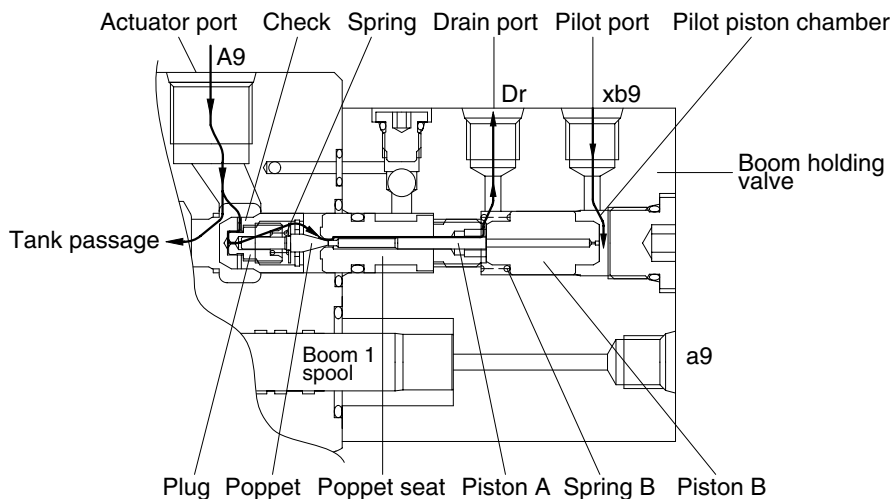

55W72MC17

The pilot pressure is supplied to the pilot port for release holding valve and shifts the piston "B" in the left direction against the spring "B", and shifts the poppet in the left direction through piston "B" and piston "A" against spring "B" and shifts the spool in the left side.

At same time, the return fluid from actuator returns to the drain port through the periphery hole of check, crevice of the check and the plug, the periphery hole of the plug, in side of holding valve, crevice of the poppet and the poppet seat, the periphery hole of the poppet seat, crevice of the socket and spool and inside of spool.

When the poppet is opened, pressure of inside of holding valve is decreased and the return fluid from actuator returns to the tank passage through the notch of spool.