

GROUP 9 BOOM, ARM AND BUCKET CYLINDERS

1. REMOVAL AND INSTALL

1) BUCKET CYLINDER

(1) Removal

- ※ Expand the arm and bucket fully, lower the work equipment to the ground and stop the engine.
- ※ Operate the control levers and pedals several times to release the remaining pressure in the hydraulic piping.

▲ Loosen the breather slowly to release the pressure inside the hydraulic tank. Escaping fluid under pressure can penetrate the skin causing serious injury.

- ※ Fit blind plugs in the hoses after disconnecting them, to prevent dirt or dust from entering.

① Set block between bucket cylinder and arm.

② Remove bolt (2), nut (3) and pull out pin (1).

- ※ Tie the rod with wire to prevent it from coming out.

③ Disconnect bucket cylinder hoses (4) and put plugs (5) on cylinder pipe.

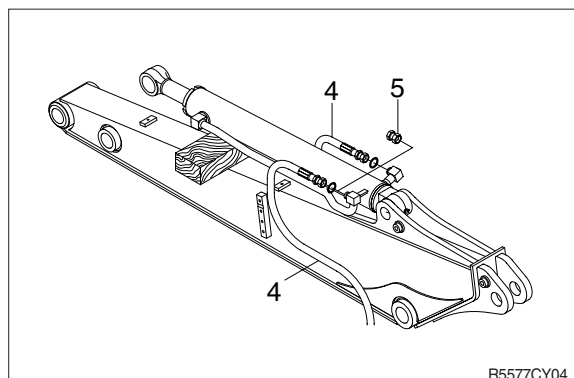
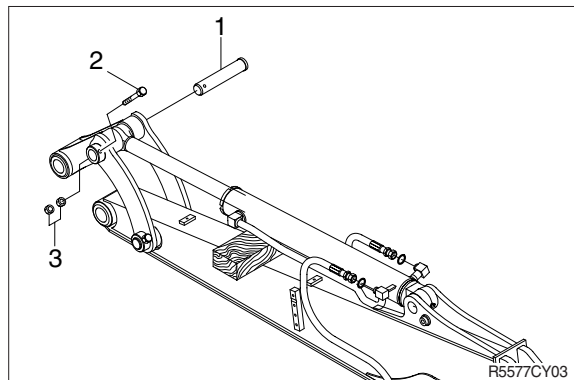
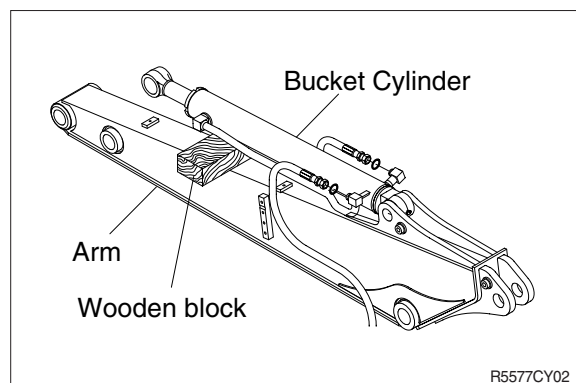

- ④ Sling bucket cylinder assembly (8) and remove bolt (6) then pull out pin (5).
- ⑤ Remove bucket cylinder assembly (8).
 - Weight : 30 kg (70 lb)

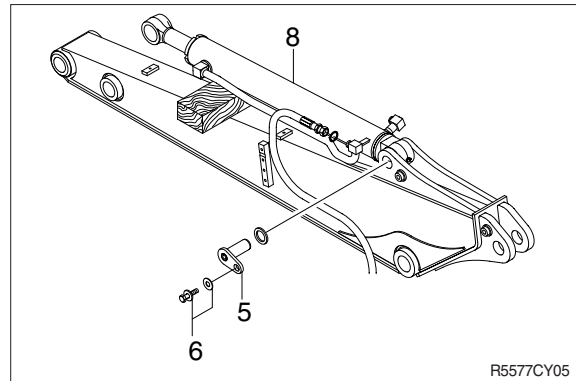

(2) Install

- ① Carry out installation in the reverse order to removal.
- ▲ When aligning the mounting position of the pin, do not insert your fingers in the pin hole.**
- ※ Bleed the air from the bucket cylinder.
 - ※ Confirm the hydraulic oil level and check the hydraulic oil leak or not.

2) ARM CYLINDER

(1) Removal

- ※ Expand the arm and bucket fully, lower the work equipment to the ground and stop the engine.
- ※ Operate the control levers and pedals several times to release the remaining pressure in the hydraulic piping.

▲ Loosen the breather slowly to release the pressure inside the hydraulic tank.

▲ Escaping fluid under pressure can penetrate the skin causing serious injury.

- ※ Fit blind plugs in the hoses after disconnecting them, to prevent dirt or dust from entering.

① Set block between arm cylinder and boom.

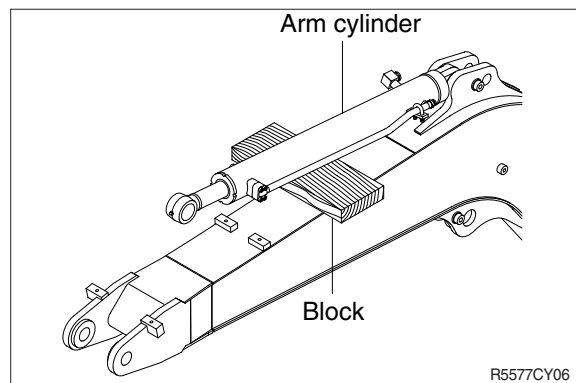

② Remove bolt (2) and pull out pin (1).

- ※ Tie the rod with wire to prevent it from coming out.

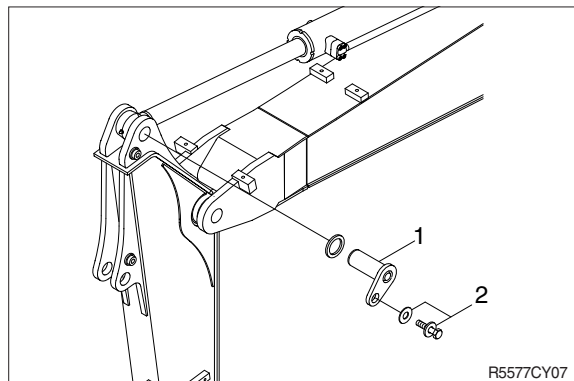

③ Disconnect arm cylinder hoses (4) and put plugs on cylinder pipe.

④ Disconnect greasing pipings (5).

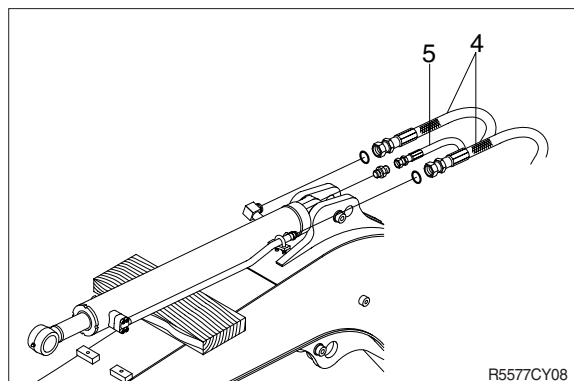

- ⑤ Sling arm assembly (8) and remove bolt (7) then pull out pin (6).
- ⑥ Remove arm cylinder assembly (8).
 - Weight : 50 kg (110 lb)

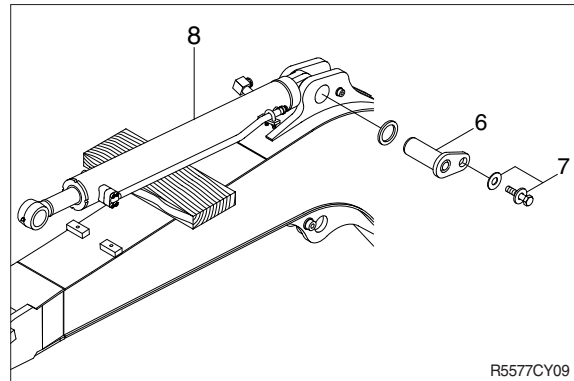

(2) Install

- ① Carry out installation in the reverse order to removal.
- ▲ When aligning the mounting position of the pin, do not insert your fingers in the pin hole.**
- ※ Bleed the air from the arm cylinder.
 - ※ Confirm the hydraulic oil level and check the hydraulic oil leak or not.

3) BOOM CYLINDER

(1) Removal

- ※ Expand the arm and bucket fully, lower the work equipment to the ground and stop the engine.
- ※ Operate the control levers and pedals several times to release the remaining pressure in the hydraulic piping.

▲ Loosen the breather slowly to release the pressure inside the hydraulic tank.

▲ Escaping fluid under pressure can penetrate the skin causing serious injury.

- ※ Fit blind plugs in the hoses after disconnecting them, to prevent dirt or dust from entering.

- ① Disconnect greasing hoses (1).
- ② Sling boom cylinder assembly.

- ③ Remove bolt (2) and pull out pin (1).
- ※ Tie the rod with wire to prevent it from coming out.

- ④ Lower the boom cylinder assembly (3) on a stand.

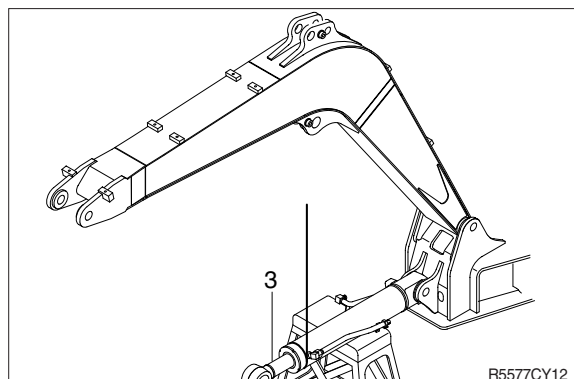
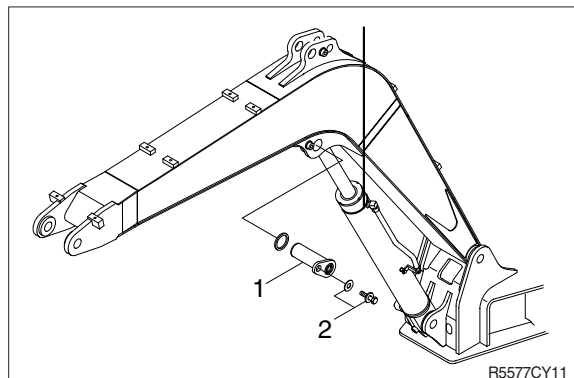
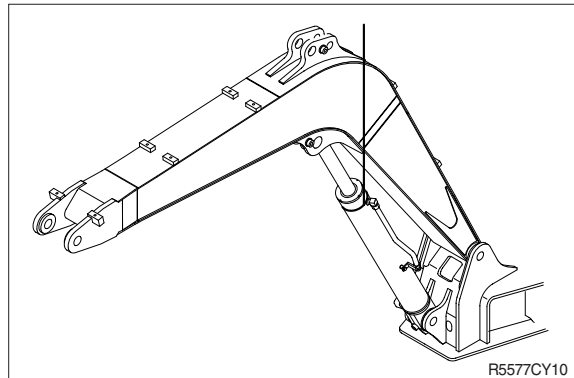

- ⑤ Disconnect boom cylinder hoses (4) and put plugs on cylinder pipe.

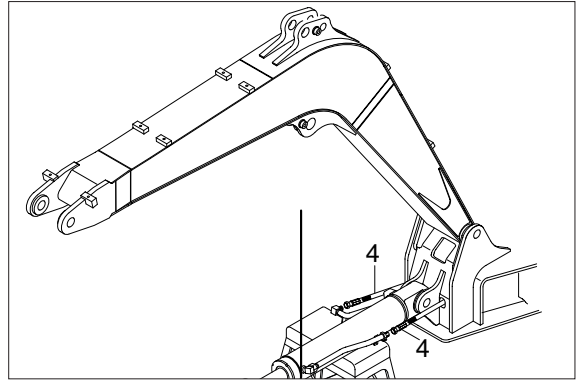

- ⑥ Remove bolt (6) and pull out pin (5).
⑦ Remove boom cylinder assembly (3).
· Weight : 60 kg (130 lb)

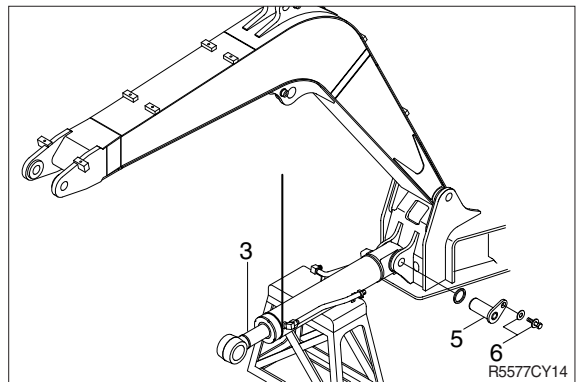

(2) Install

- ① Carry out installation in the reverse order to removal.

▲ When aligning the mounting position of the pin, do not insert your fingers in the pin hole.

- ※ Bleed the air from the boom cylinder.
- ※ Confirmed the hydraulic oil level and check the hydraulic oil leak or not.

2. DISASSEMBLY AND ASSEMBLY

1) STRUCTURE

(1) Bucket cylinder

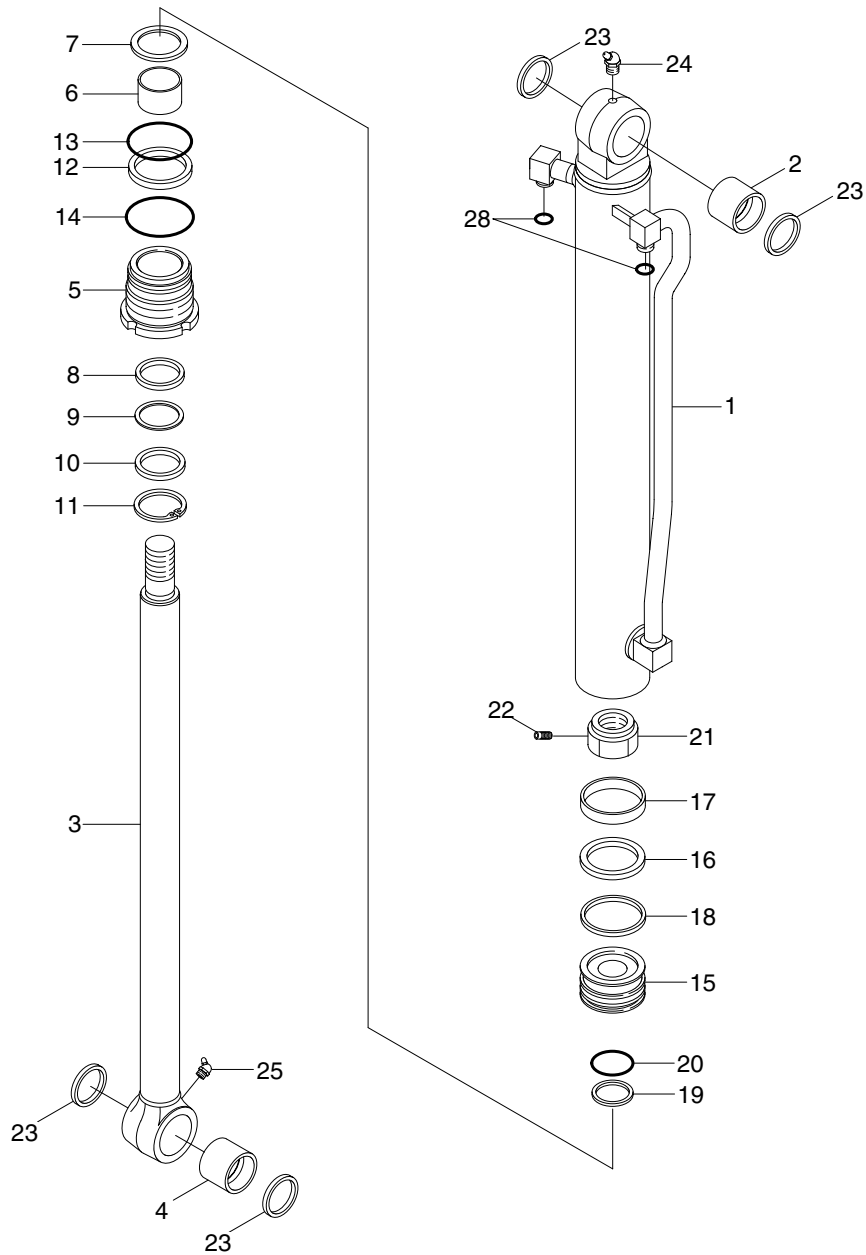

555C97CY22

- | | | | | | |
|---|----------------|----|----------------|----|---------------|
| 1 | Tube assembly | 10 | Dust seal | 19 | Back-up ring |
| 2 | Bushing | 11 | Retaining ring | 20 | O-ring |
| 3 | Bushing | 12 | Back-up ring | 21 | Piston nut |
| 4 | Du bushing | 13 | O-ring | 22 | Set screw |
| 5 | Rod cover | 14 | O-ring | 23 | Dust seal |
| 6 | Rod bushing | 15 | Piston | 24 | Grease nipple |
| 7 | Retaining ring | 16 | Piston seal | 25 | Grease nipple |
| 8 | Buffer ring | 17 | Wear ring | 28 | O-ring |
| 9 | U-packing | 18 | Dust ring | | |

(2) Arm cylinder

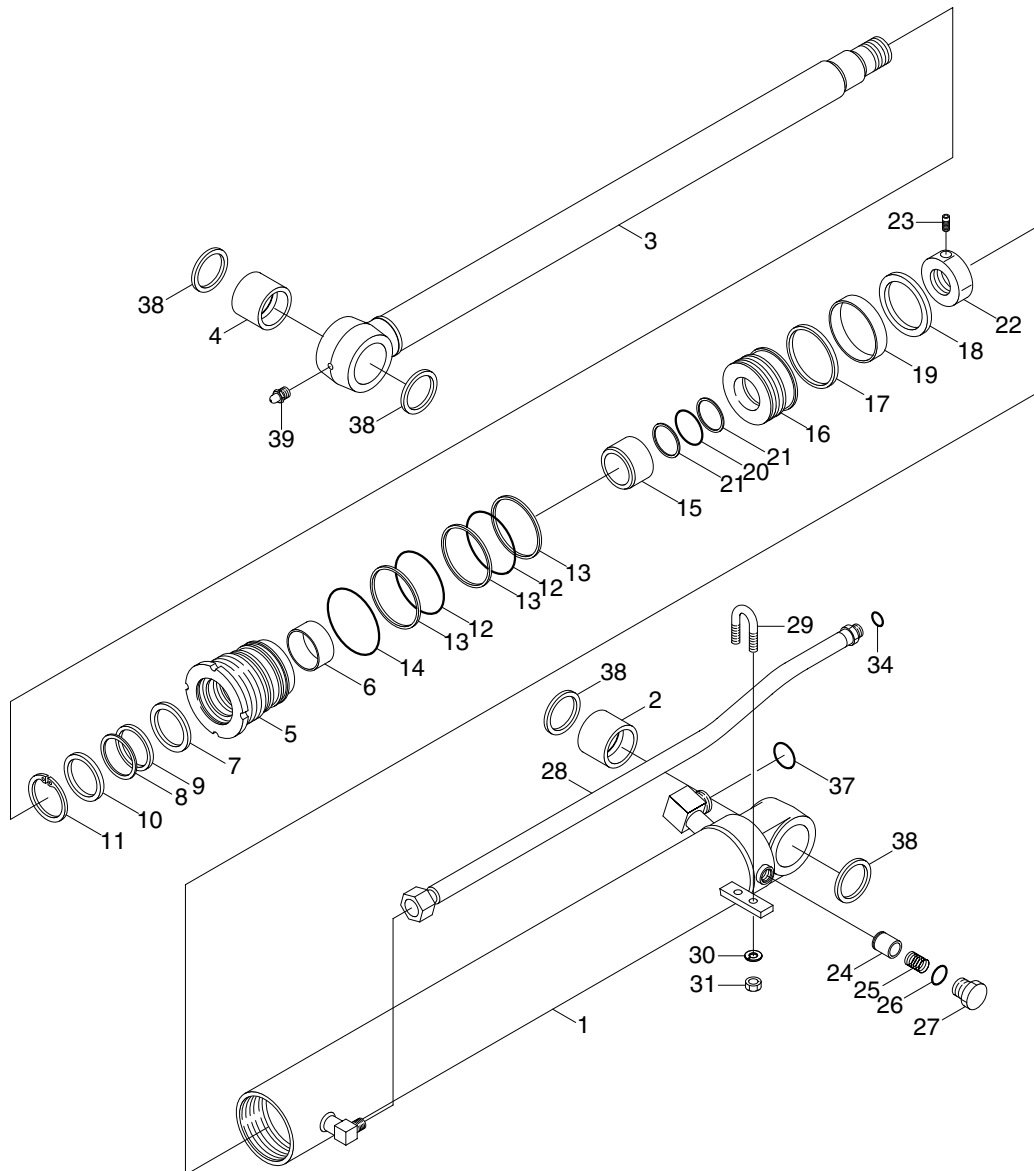

555C97CY24

- | | | | | | |
|----|----------------|----|--------------|----|----------------|
| 1 | Tube assembly | 12 | O-ring | 23 | Set screw |
| 2 | Bushing | 13 | Back-up ring | 24 | Check valve |
| 3 | Bushing | 14 | O-ring | 25 | Spring |
| 4 | DD2 bushing | 15 | Cushion ring | 26 | Support spring |
| 5 | Rod cover | 16 | Piston | 29 | U-bolt |
| 6 | Rod bushing | 17 | Piston seal | 30 | Spring washer |
| 7 | Buffer seal | 18 | Wear ring | 31 | Hex nut |
| 8 | U-packing | 19 | Dust ring | 34 | O-ring |
| 9 | Back-up ring | 20 | Wear ring | 37 | O-ring |
| 10 | Dust wiper | 21 | Back-up ring | 38 | Dust seal |
| 11 | Retaining ring | 22 | Piston nut | 39 | Grease nipple |

(3) Boom cylinder

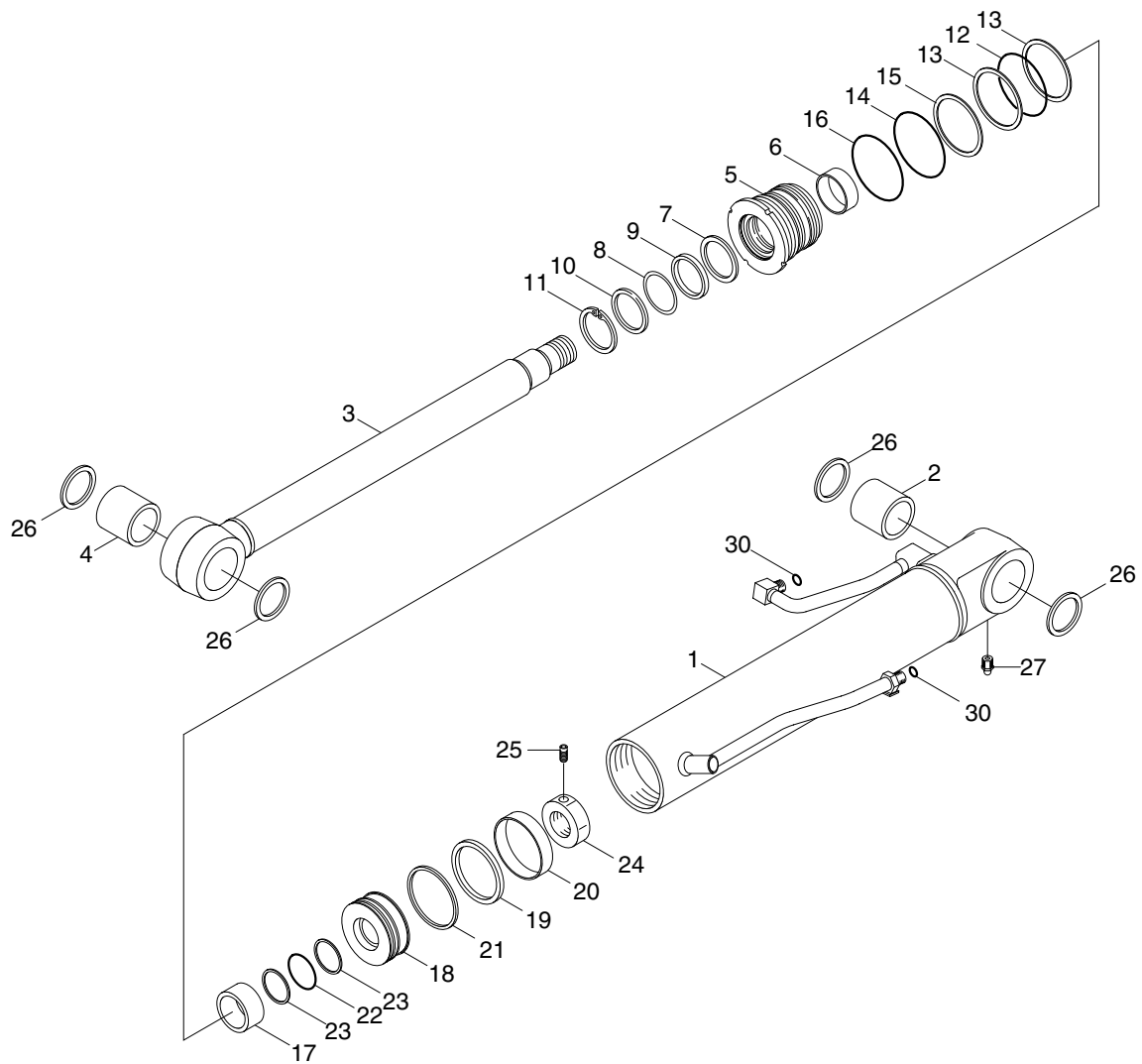

555C97CY21

- | | | | | | |
|----|---------------|----|----------------|----|---------------|
| 1 | Tube assembly | 11 | Retaining ring | 21 | Dust ring |
| 2 | Bushing | 12 | O-ring | 22 | O-ring |
| 3 | Bushing | 13 | Back-up ring | 23 | Back-up ring |
| 4 | Du bushing | 14 | O-ring | 24 | Piston nut |
| 5 | Rod cover | 15 | Back-up ring | 25 | Set screw |
| 6 | Rod bushing | 16 | O-ring | 26 | Dust seal |
| 7 | Buffer ring | 17 | Cushion ring | 27 | Grease nipple |
| 8 | U-packing | 18 | Piston | 30 | O-ring |
| 9 | Back-up ring | 19 | Piston seal | | |
| 10 | Dust seal | 20 | Wear ring | | |

(4) Dozer cylinder

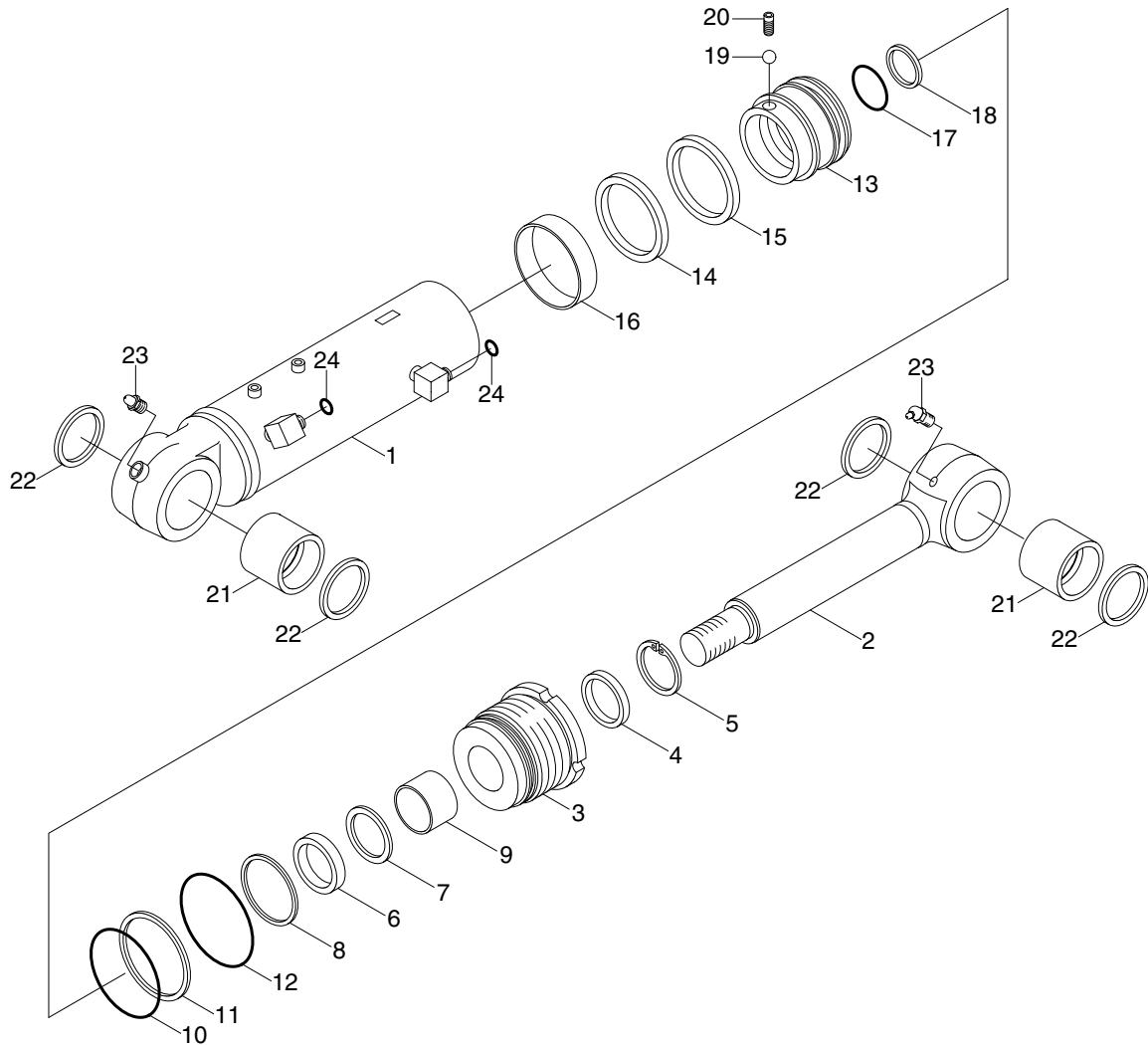

5597CY23

- | | | | | | |
|---|----------------|----|--------------|----|---------------|
| 1 | Tube assembly | 9 | DU bushing | 17 | O-ring |
| 2 | Rod assembly | 10 | O-ring | 18 | Back-up ring |
| 3 | Gland | 11 | Back-up ring | 19 | Steel ball |
| 4 | Dust wiper | 12 | O-ring | 20 | Set screw |
| 5 | Retaining ring | 13 | Piston | 21 | Bushing |
| 6 | Rod seal | 14 | Piston seal | 22 | Dust seal |
| 7 | Back-up ring | 15 | Dust ring | 23 | Grease nipple |
| 8 | Buffer ring | 16 | Wear ring | 24 | O-ring |

(5) Boom swing cylinder

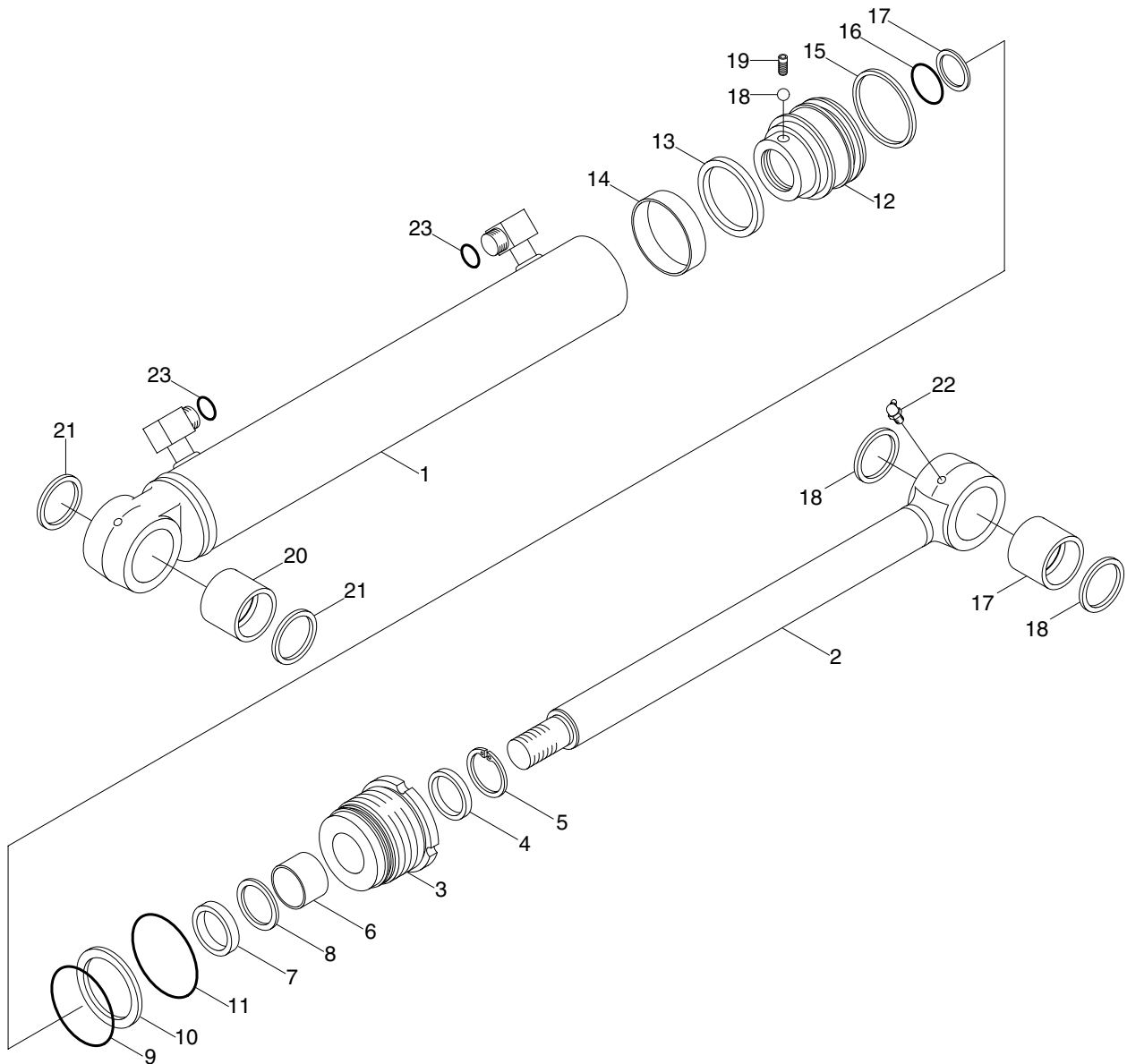

5596MC02

- | | | | | | |
|---|----------------|----|--------------|----|---------------|
| 1 | Tube assembly | 9 | O-ring | 17 | Back-up ring |
| 2 | Rod assembly | 10 | Buck-up ring | 18 | Steel ball |
| 3 | Gland | 11 | O-ring | 19 | Set screw |
| 4 | Dust wiper | 12 | Piston | 20 | Pin bushing |
| 5 | Retaining ring | 13 | Piston seal | 21 | Dust seal |
| 6 | DU bushing | 14 | Wear ring | 22 | Grease nipple |
| 7 | Rod seal | 15 | Dust ring | 23 | O-ring |
| 8 | Buck-up ring | 16 | O-ring | | |

2) TOOLS AND TIGHTENING TORQUE

(1) Tools

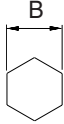
Name	Specification	
Allen wrench	8	
	10	
Spanner	M22	
Hook spanner	Suitable size	
(-) Driver	Small and large sizes	
Torque wrench	Capable of tightening with the specified torques	

(2) Tightening torque

Part name		Item	Size	Torque	
				kgf · m	lbf · ft
Rod cover	Boom cylinder	3	M115	70±7.0	510±51
	Arm cylinder	3	M95	70±7.0	510±51
	Bucket cylinder	3	M85	75±7.5	540±54
	Dozer cylinder	3	M115	95±9.5	690±69
	Boom swing cylinder	3	M100	70±7.0	510±51
Piston nut	Boom cylinder	22	M45	75±7.5	540±54
	Arm cylinder	21	M39	75±7.5	540±54
	Bucket cylinder	19	M36	75±7.5	540±54
	Dozer cylinder	16	M45	113±11.3	817±137
	Boom swing cylinder	12	M39	97.5±9.8	705±71

3) DISASSEMBLY

(1) Remove cylinder head and piston rod

- ① Hold the clevis section of the tube in a vise.
- ※ Use mouth pieces so as not to damage the machined surface of the cylinder tube. Do not make use of the outside piping as a locking means.

- ② Pull out rod assembly (3) about 200 mm (7.1 in). Because the rod assembly is rather heavy, finish extending it with air pressure after the oil draining operation.

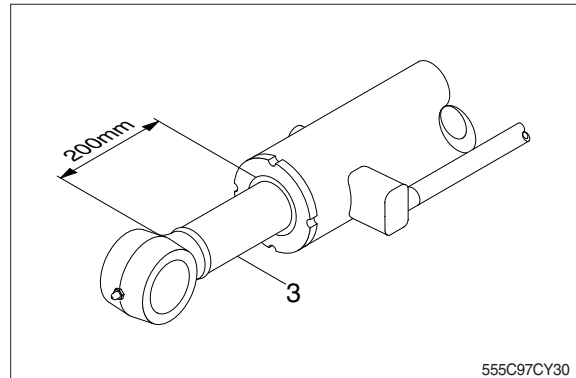

- ③ Remove rod cover (5) by hook spanner.
- ※ Cover the extracted rod assembly (3) with rag to prevent it from being accidentally damaged during operation.

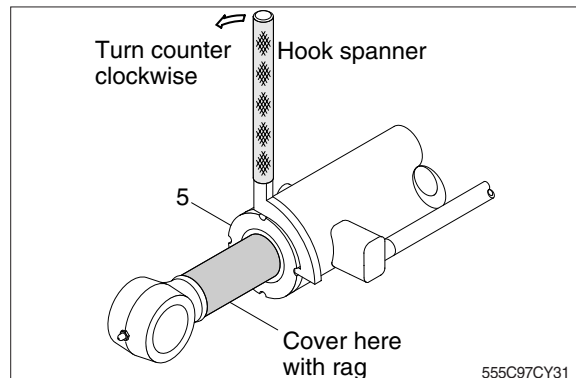

- ④ Draw out cylinder head and rod assembly (3) together from tube assembly (1).
- ※ Since the rod assembly is heavy in this case, lift the tip of the rod assembly (3) with a crane or some means and draw it out. However, when rod assembly (3) has been drawn out to approximately two thirds of its length, lift it in its center to draw it completely.

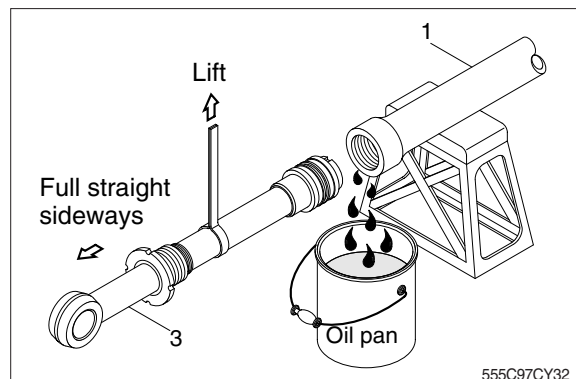

Note that the plated surface of rod assembly (3) is to be lifted. For this reason, do not use a wire sling and others that may damage it, but use a strong cloth belt or a rope.

- ⑤ Place the removed rod assembly on a wooden V-block that is set level.
- ※ Cover a V-block with soft rag.

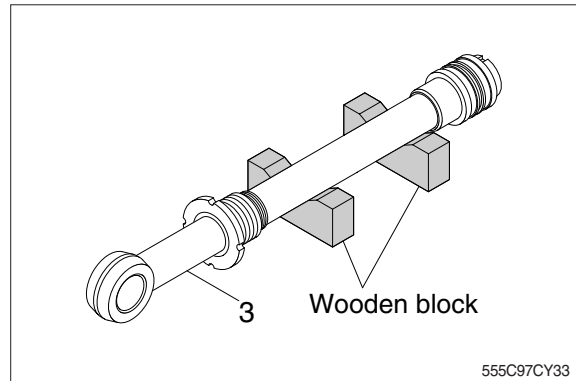

(2) Remove piston and rod cover

- ① Loosen set screw (22) and remove piston nut (21).
- ※ Since piston nut (21) is tightened to a high torque, use a hydraulic and power wrench that utilizes a hydraulic cylinder, to remove the piston nut (21).
- ② Remove piston assembly (15), back up ring (19), and O-ring (20).

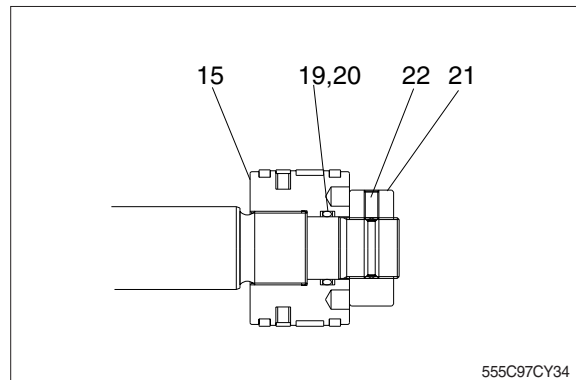

- ③ Remove the rod cover from rod assembly (3).
 - ※ If it is too heavy to move, move it by striking the flanged part of gland with a plastic hammer.
 - ※ Pull it straight with cylinder head assembly lifted with a crane.
- Exercise care so as not to damage the lip of Du bushing (6) and packing (8, 9, 10, 11, 12, 13, 14) by the threads of rod assembly (3).

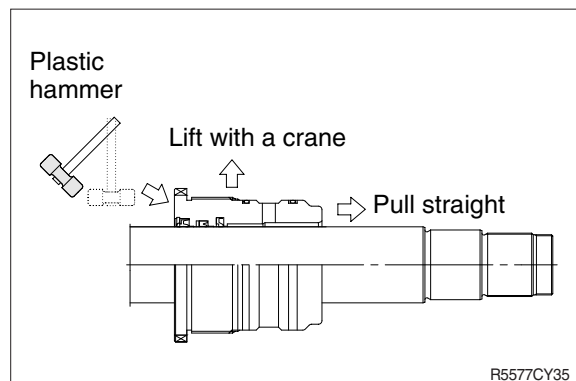

(3) Disassemble the piston assembly

- ① Remove wear ring (17).
 - ② Remove dust ring (18) and piston seal (16).
- ※ Exercise care in this operation not to damage the grooves.

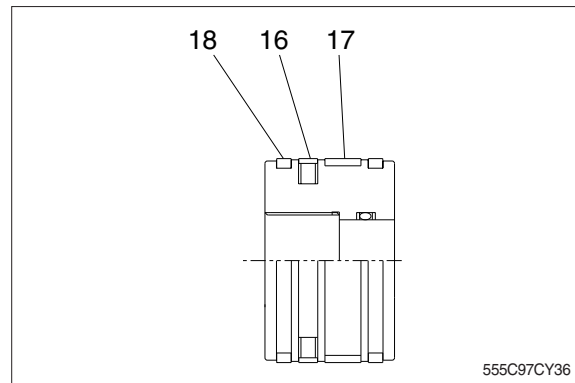

(4) Disassemble gland assembly

- ① Remove back up ring (12) and O-ring (13).
 - ② Remove snap ring (11), dust wiper (10).
 - ③ Remove U-packing (9) and buffer seal (8).
- ※ Exercise care in this operation not to damage the grooves.
- ※ Do not remove seal and ring, if does not damaged.

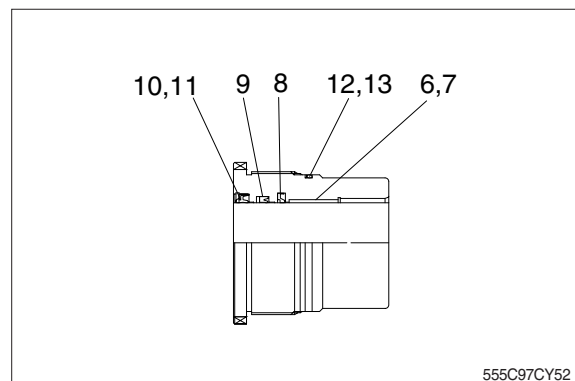

4) ASSEMBLY

(1) Assemble cylinder head assembly

- ※ Check for scratches or rough surfaces if found smooth with an oil stone.
- ① Coat the inner face of rod cover (5) with hydraulic oil.

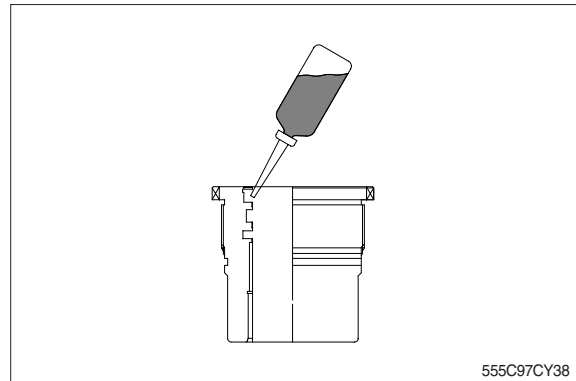

- ② Coat dust wiper (10) with grease and fit dust wiper (10) to the bottom of the hole of dust seal.
At this time, press a pad metal to the metal ring of dust seal.
- ③ Fit snap ring (11) to the stop face.

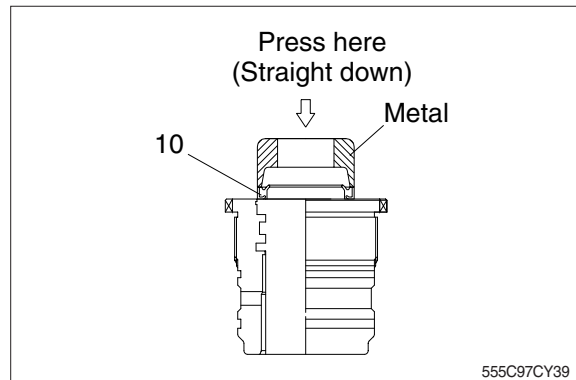

- ④ Fit U-packing (9) and buffer seal (8) to corresponding grooves, in that order.
- ※ Coat each packing with hydraulic oil before fitting it.
- ※ Insert the backup ring until one side of it is inserted into groove.

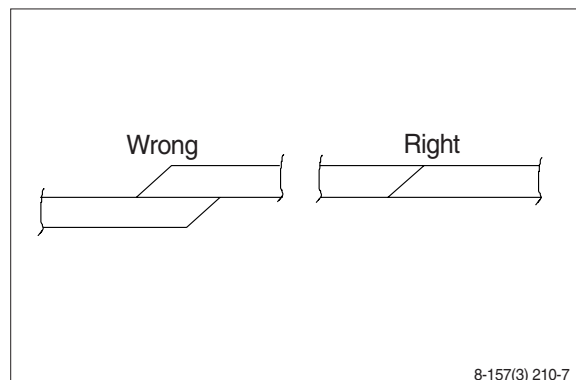

- ※ U-packing (9) has its own fitting direction. Therefore, confirm it before fitting them.
- ※ Fitting U-packing (9) upside down may damage its lip. Therefore check the correct direction that is shown in fig.

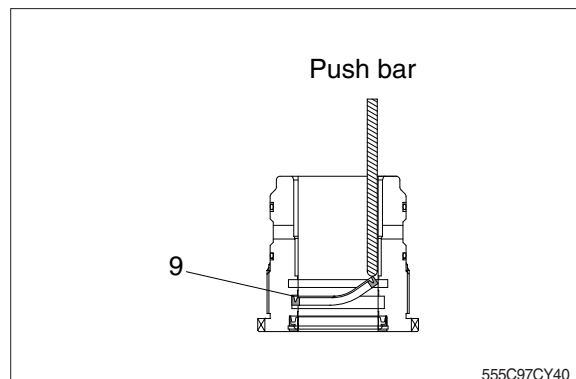

- ⑤ Fit back up ring (12) to rod cover (5).
- ※ Put the backup ring in the warm water of 30~50°C .
- ⑥ Fit O-ring (13) to rod cover (5).

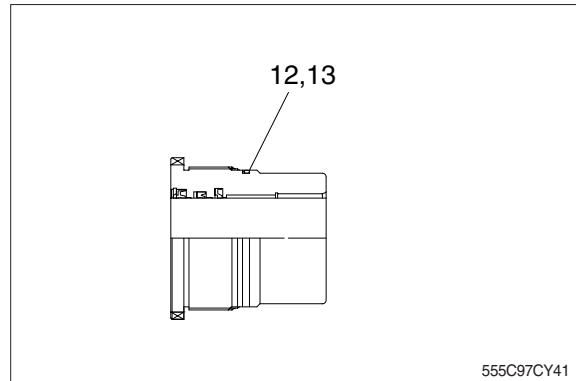

(2) Assemble piston assembly

- ※ Check for scratches or rough surfaces.
If found smooth with an oil stone.
- ① Coat the outer face of piston (15) with hydraulic oil.

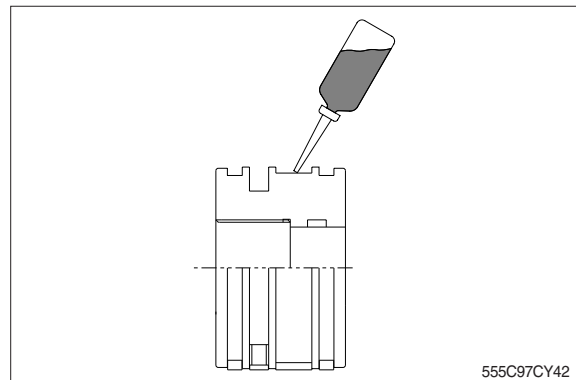

- ② Fit piston seal (16) to piston.
- ※ Put the piston seal in the warm water of 60~100°C for more than 5 minutes.
- ※ After assembling the piston seal, press its outer diameter to fit in.

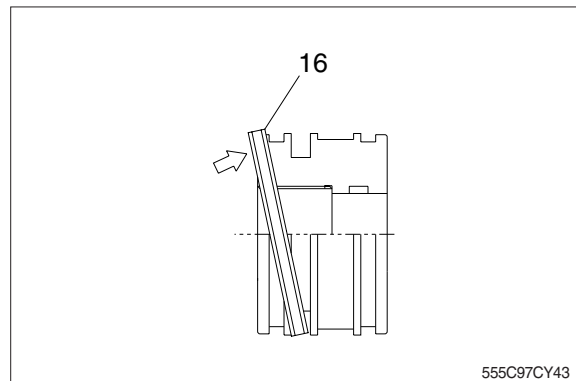

- ③ Fit wear ring (17) and dust ring (18) to piston (15).

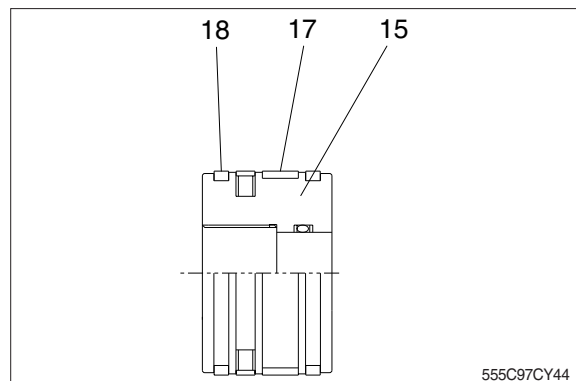

(3) Install piston and cylinder head

- ① Fix the rod assembly to the work bench.
- ② Apply hydraulic oil to the outer surface of rod assembly (3), the inner surface of piston and cylinder head.
- ③ Insert cylinder head assembly to rod assembly.

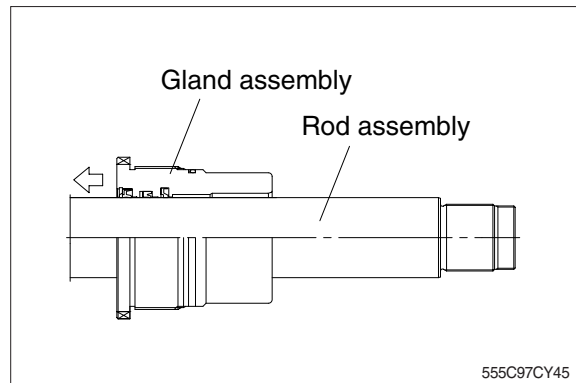

- ⑤ Fit piston assembly to rod assembly.

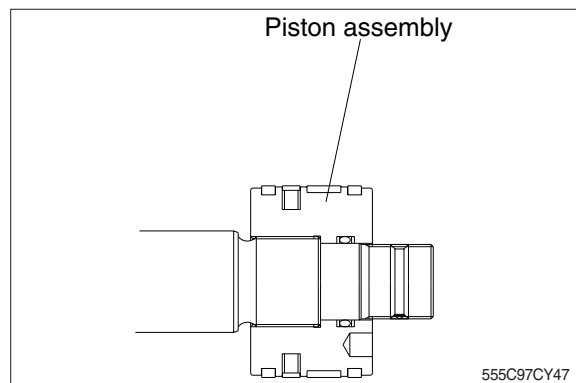

- ⑥ Fit piston nut and tighten the set screw (22).

· Tightening torque :

Item		kgf · m	lbf · ft
Boom	22	75 ± 7.5	540 ± 54
Arm	21	75 ± 7.5	540 ± 54
Bucket	19	75 ± 7.5	540 ± 54
Dozer	16	113 ± 11.3	817 ± 137
Boom swing	12	97.5 ± 9.8	705 ± 71

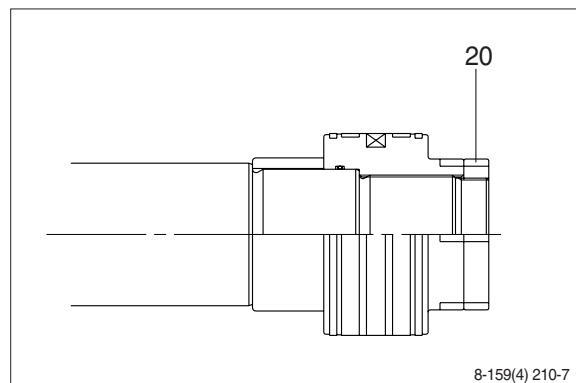

(3) Overall assemble

- ① Place a V-block on a rigid work bench.
Mount the tube assembly (2) on it and fix the assembly by passing a bar through the clevis pin hole to lock the assembly.
- ② Insert the rod assembly in to the tube assembly, while lifting and moving the rod assembly with a crane.
 - ※ Be careful not to damage piston seal by thread of tube assembly.
- ③ Match the bolt holes in the cylinder head flange to the tapped holes in the tube assembly and tighten socket bolts to a specified torque.
 - ※ Refer to the table of tightening torque.

