

GROUP 5 SWING DEVICE

1. REMOVAL AND INSTALL OF MOTOR

1) REMOVAL

- (1) Lower the work equipment to the ground and stop the engine.
- (2) Operate the control levers and pedals several times to release the remaining pressure in the hydraulic piping.
- (3) Loosen the breather slowly to release the pressure inside the hydraulic tank.

▲ Escaping fluid under pressure can penetrate the skin causing serious injury.

※ When pipes and hoses are disconnected, the oil inside the piping will flow out, so catch it in oil pan.

- (4) Disconnect hose assembly (2, 3).
- (5) Disconnect pilot line hoses (4, 5, 6, 7, 8).
- (6) Sling the swing motor assembly (1) and remove the swing motor mounting bolts (9).

※ Motor device weight : 23 kg (51 lb)

- (7) Remove the swing motor assembly.
※ When removing the swing motor assembly, check that all the piping have been disconnected.

2) INSTALL

- (1) Carry out installation in the reverse order to removal.
- (2) Bleed the air from the swing motor.
 - ① Remove the air vent plug.
 - ② Pour in hydraulic oil until it overflows from the port.
 - ③ Tighten plug lightly.
 - ④ Start the engine, run at low idling and check oil come out from plug.
 - ⑤ Tighten plug fully.
- (3) Confirm the hydraulic oil level and check the hydraulic oil leak or not.

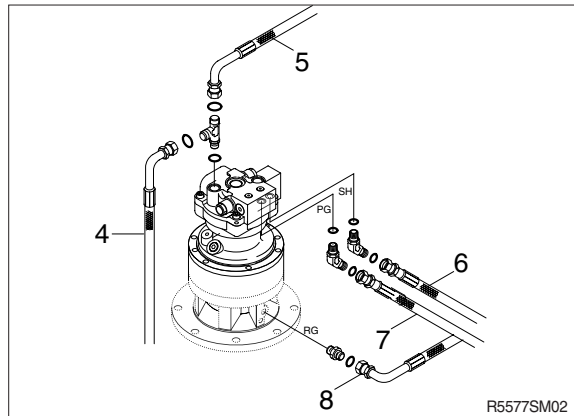
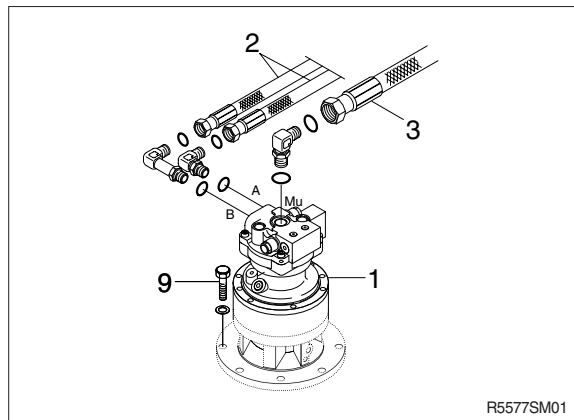

2. DISASSEMBLY AND ASSEMBLY OF SWING MOTOR

1) STRUCTURE

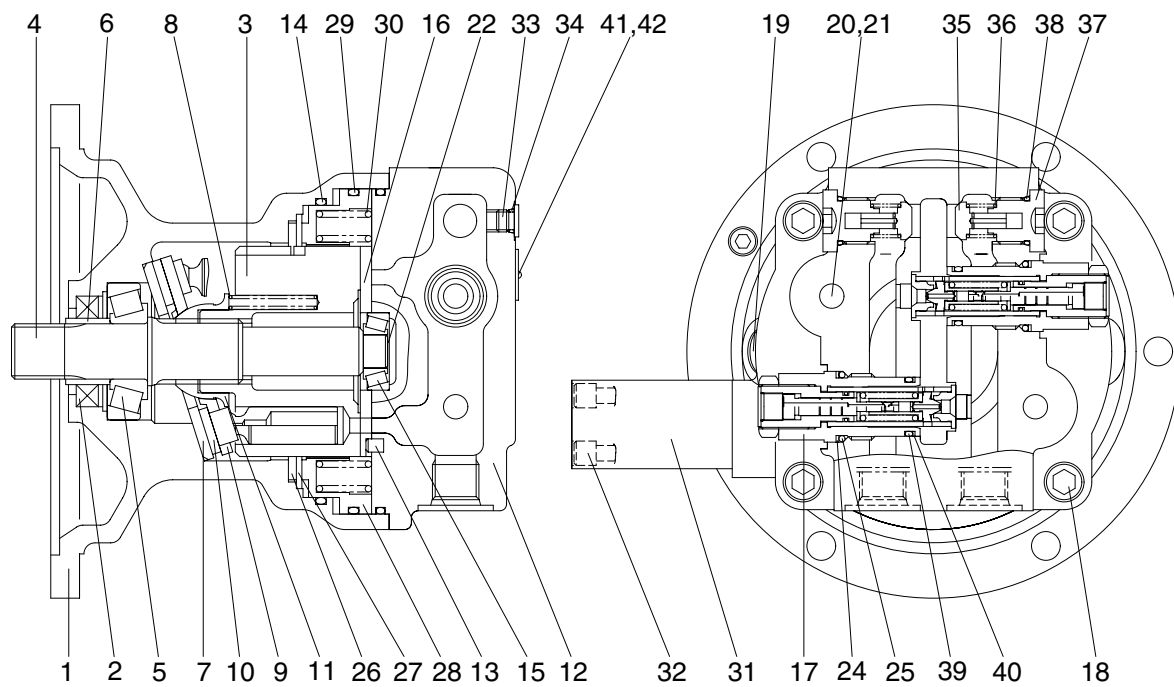

555K2SM03

1	Body	15	Taper bearing	29	O-ring
2	Oil seal	16	Valve plate	30	Spring
3	Cylinder block	17	Relief valve assy	31	Time delay valve
4	Shaft	18	Socket bolt	32	Socket bolt
5	Taper bearing	19	Plug	33	Plug
6	Bushing	20	Plug	34	O-ring
7	Shoe plate	21	O-ring	35	Valve
8	Spring	22	Shim	36	Spring
9	Set plate	23	Plug	37	Plug
10	Piston shoe assy	24	Back up ring	38	O-ring
11	Ball guide	25	O-ring	39	O-ring
12	Rear cover	26	Friction plate	40	Back up ring
13	Pin	27	Plate	41	Name plate
14	O-ring	28	Parking piston	42	Rivet

2) DISASSEMBLY

- (1) Removal of relief valve assembly
Remove cap of relief valve assembly (17) with 14 mm hexagonal wrench.
※ Assemble removed relief valve assembly (17) to original state when reassembling.

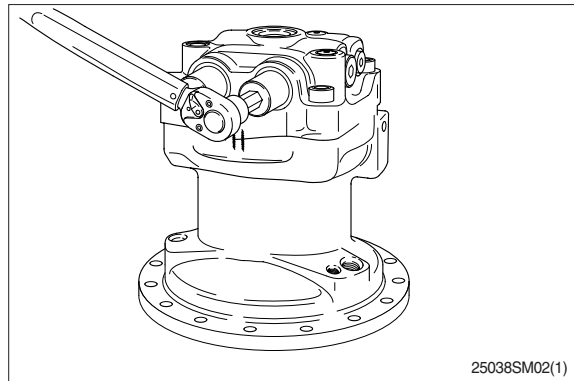

- (2) Removal of make up valve and bypass valve assembly
Loosen plug (37) with 14 mm hexagonal wrench, and remove check valve (35) and spring (36).

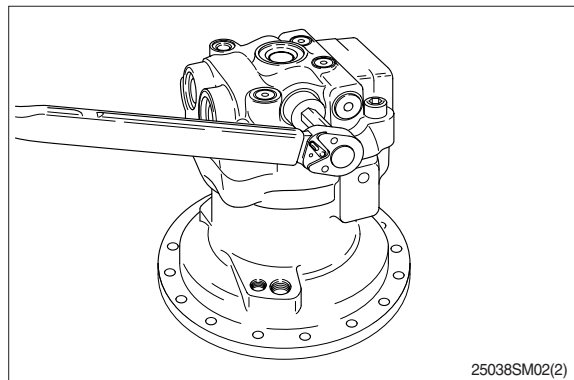

- (3) Marking at swing motor
Before disassembling motor, make a matching mark between cover (12) and housing (1) for easy reassembling.

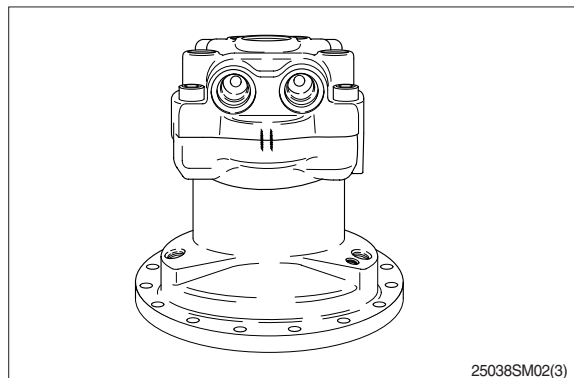

- (4) Remove mounting bolts of cover
Loosen hexagon socket bolt (18) with 12 mm hexagonal wrench.

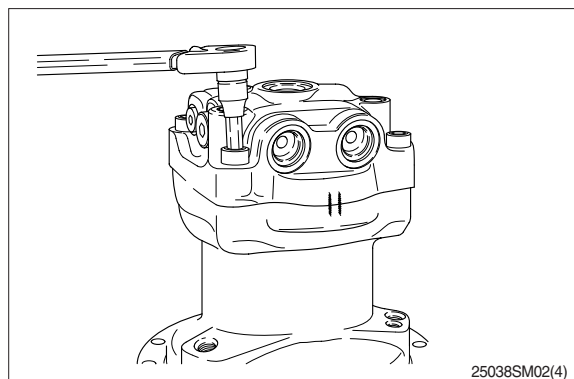

- (5) Removal of cover assembly
Place shaft of motor assembly to downward and take cover (12) out.

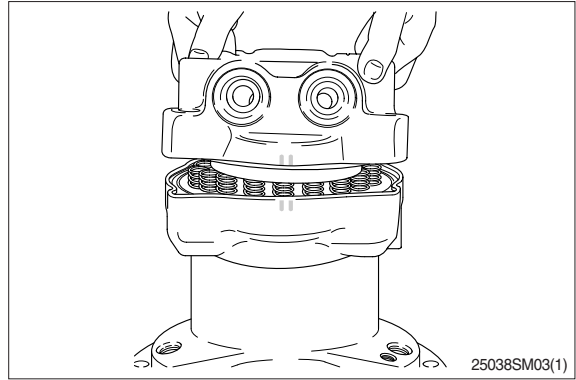

- (6) Remove shim (22) remove inner race of needle bearing (15) by bearing puller.

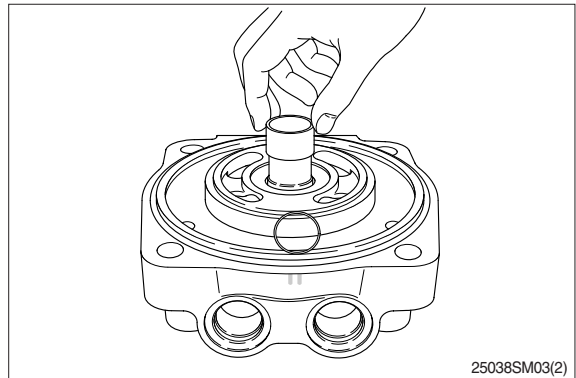

- (7) Remove O-ring (29) from cover.

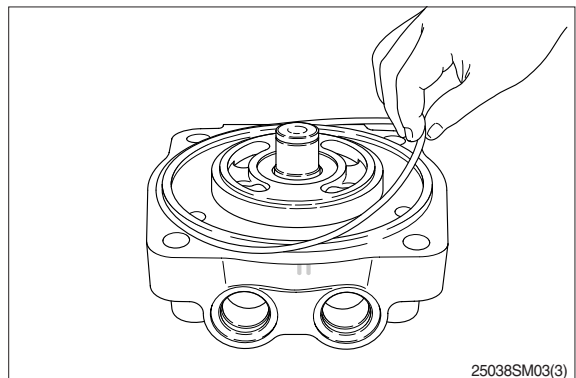

- (8) Remove balance plate
Valve plate (16) is adhered on end surface of cylinder (3) by oil viscosity. Take off balance plate (16) with hands.
Assembling method of balance plate (16) depends on cover (12).
(Band groove and round groove of high · low pressure transmission area)
Before removing, check and record location of balance plate (16) to prevent mis-assembling.

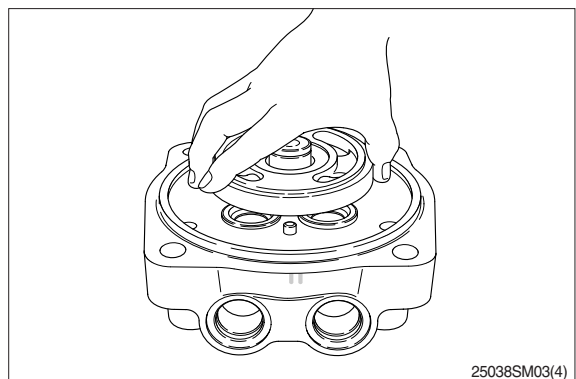

- (9) Removal of spring (30, brake area)
Remove spring (30) from piston (28).
Check and record original position of
each spring (30) for correct assembling.

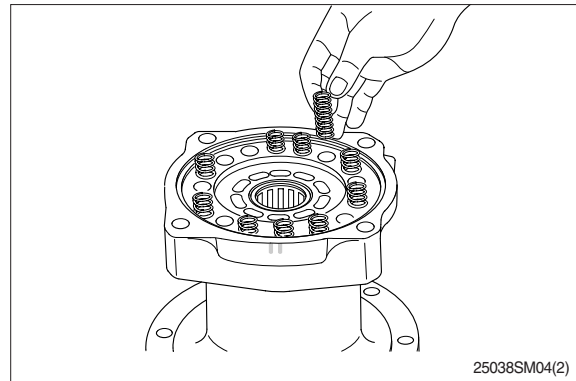

- (10) Removal of brake piston
When removing piston (28) from housing
(1), there is a sliding resistance against
tightening of O-rings (14,29). Use tap
hole on piston (28) as shown in the pic-
ture.

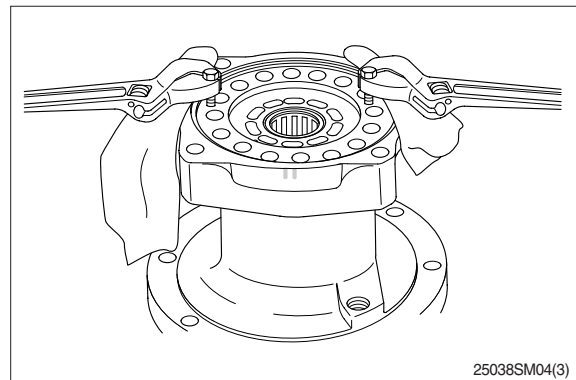

- (11) Remove O-rings (14, 29) from piston (28)
and housing (1).

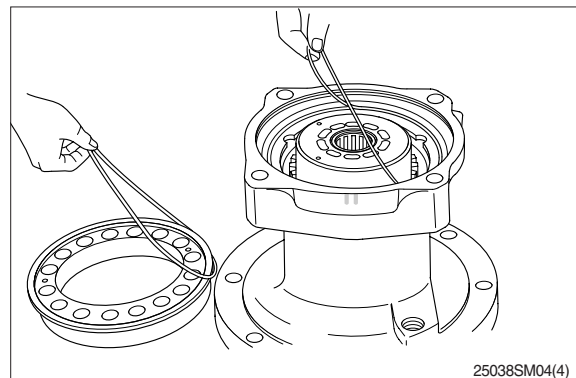

- (12) Remove friction plate (26) and lining plate
(27) from housing (1).

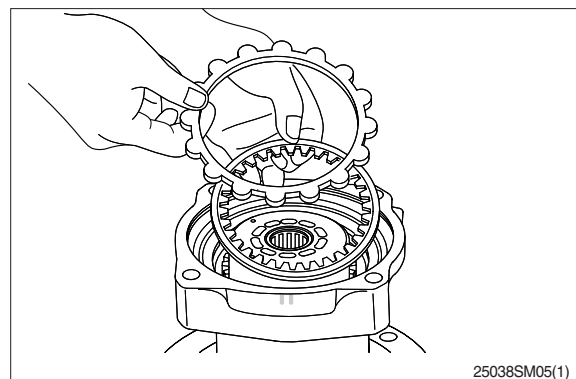

(13) Removal of cylinder assembly

Holding end of cylinder assembly (3) with hand, draw out cylinder assembly from housing.

- ※ Oil seal (2) and outer race of taper roller bearing (15) are left inside of housing.
- ※ End surface of cylinder (3) is sliding face . So, protect the surface with a scrap of cloth against damage.
- ※ Make a matching mark on piston hole of cylinder (3) and piston assembly (10) to fit piston into the same hole when reassembling.

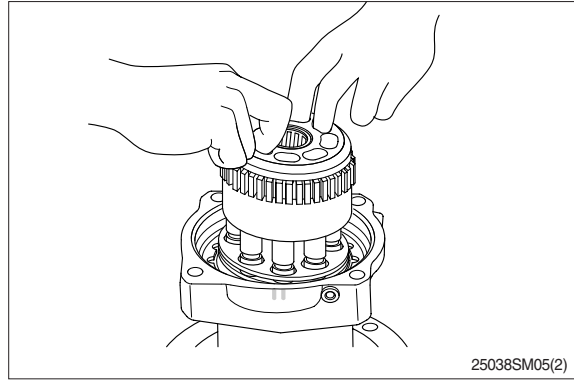

(14) Separate outer race of taper roller bearing (5) from housing.

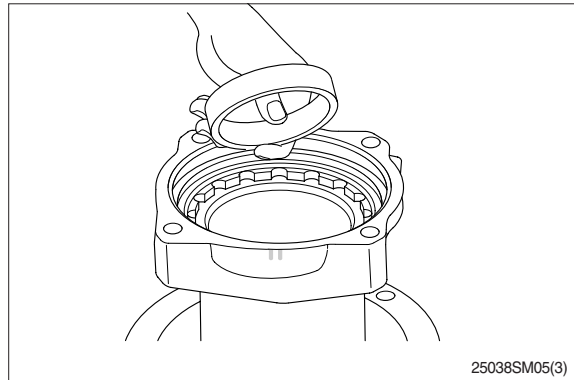

(15) Removal of oil seal

Remove oil seal (2) from housing (1) with driver and hammer.

- ※ **Do not reuse oil seal after removal.**

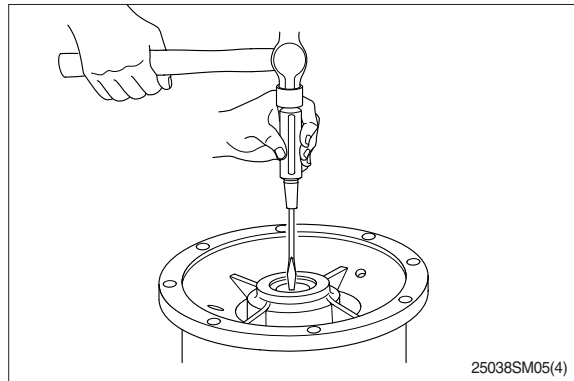

(16) Disassembly of cylinder assembly

- ① Removal of inner race of taper roller bearing (5).

Lift out cylinder block (3) with 2 inner race of roller bearing (5) by applying gear puller at the end of spline in the cylinder.

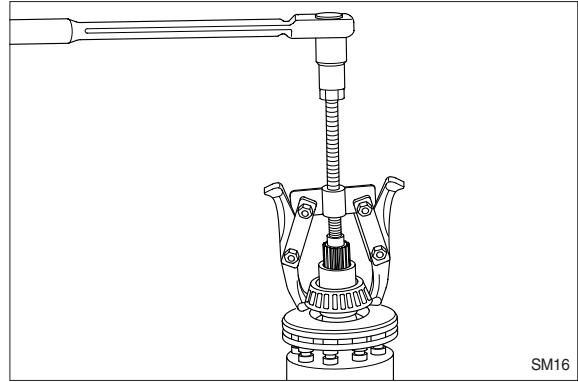

- ② Separate shoe plate (7), piston assembly (10), set plate (9) from cylinder block (3).

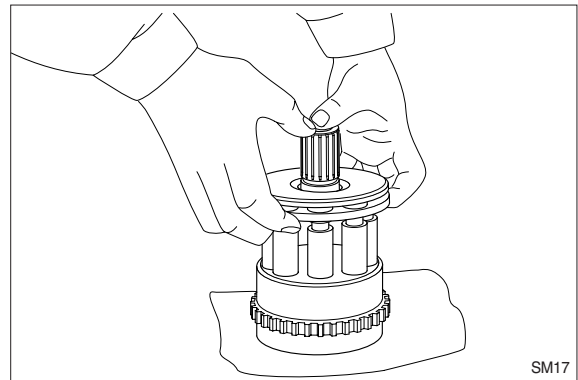

- ③ Get shoe plate (7) slide on sliding face of piston assembly (10) and remove it.

※ Be cautious not to damage on sliding face of cam plate.

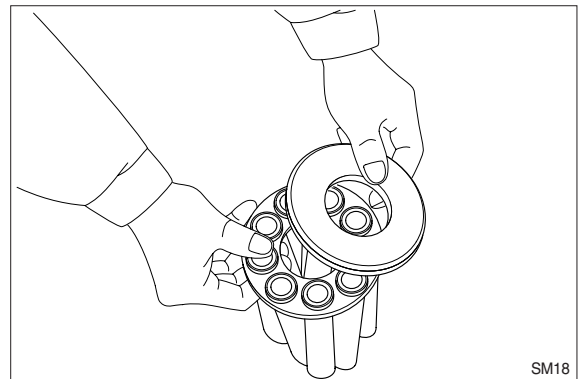

- ④ Remove ball guide (11) from cylinder block (3).

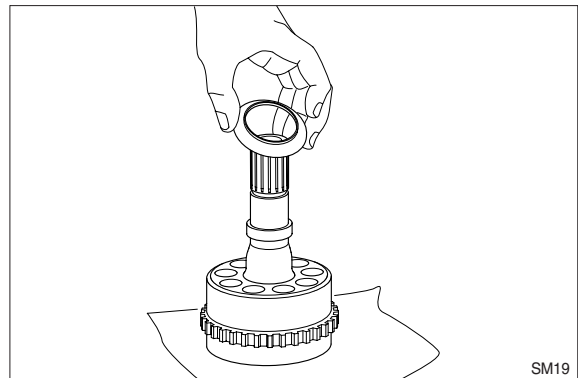

This completes disassembly.

3) ASSEMBLY

(1) Preparation

Before reassembling, perform below procedure.

- ① Check each part for damage caused by using or disassembling. If damaged, eliminate damage by grinding with proper sandpaper, wash them with cleaning oil and dry with compressed air.
- ② Replace seal with new one.
- ③ Grind sliding face of piston assembly (10), balance plate (16) and shoe plate (7) with sandpaper #2000.

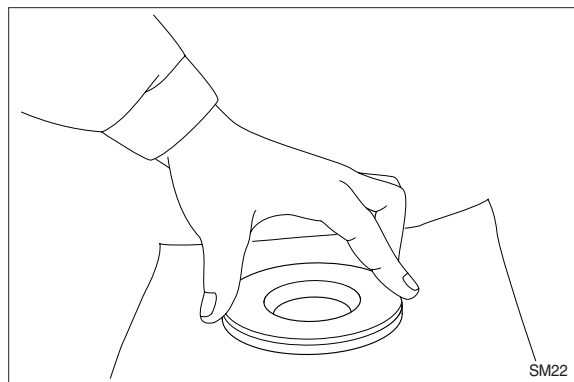
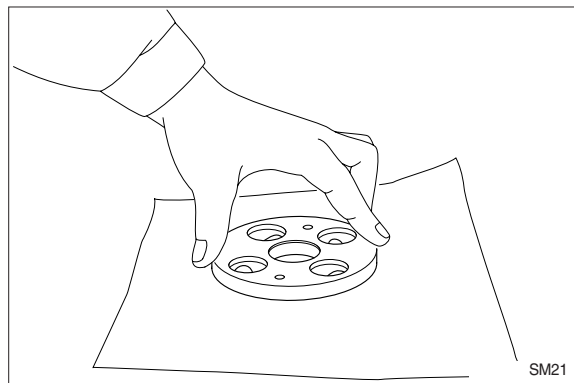
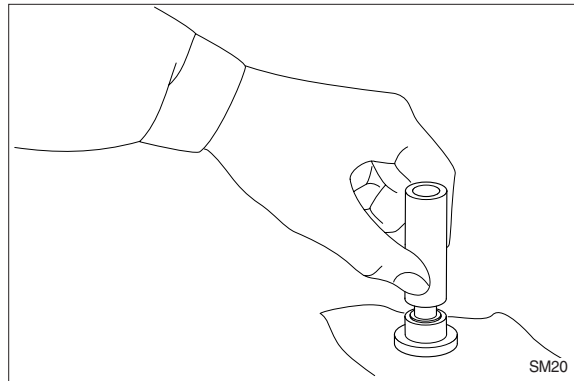

- ④ When assembling, lubricate with specified clean hydraulic oil.
- ⑤ When assembling piston assembly (10) to piston hole of cylinder block (3), check matching mark between them.

(2) Cylinder assembly

- ① Lubricate grease on round area (Contacting area with ball guide (11)) of cylinder block (3) and assemble spring (4).

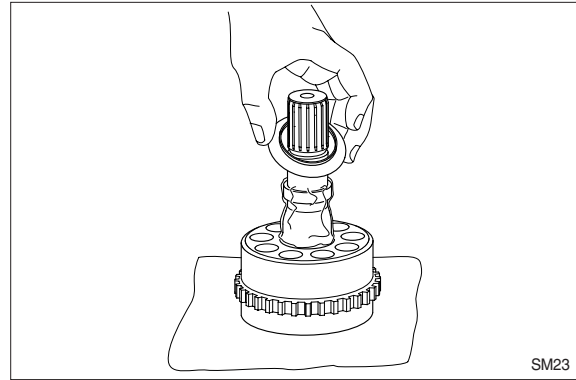

- ② Insert piston assembly (10) in hole of set plate (9).

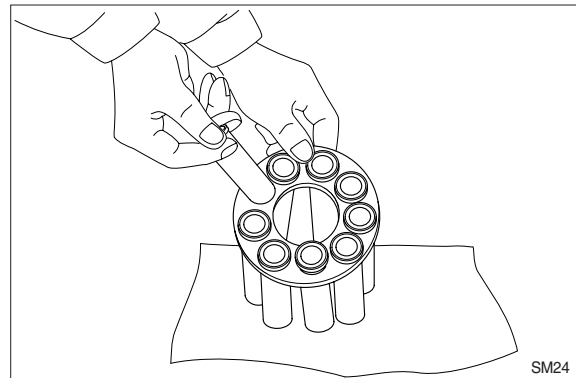

- ③ Assemble piston assembly (10) and set plate (9) to cylinder block (3). When assembling, check matching mark between them. Before assembling, lubricate specified hydraulic oil in piston hole of cylinder block (3).

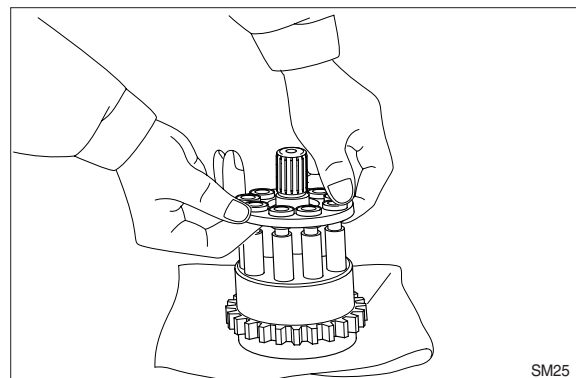

- ④ Lubricate specified hydraulic oil on shoe sliding face of piston assembly (10) and assemble shoe plate (7).

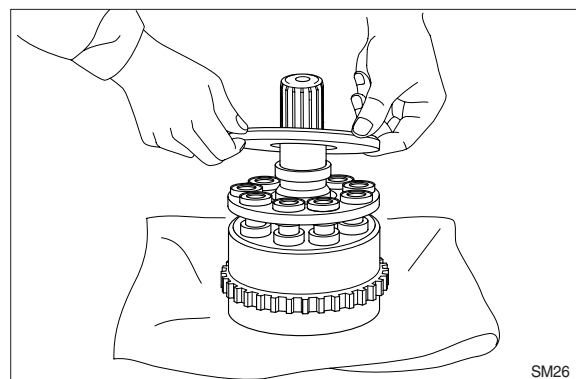

- ⑤ Assemble inner race of taper roller bearing (5) to cylinder block (3).

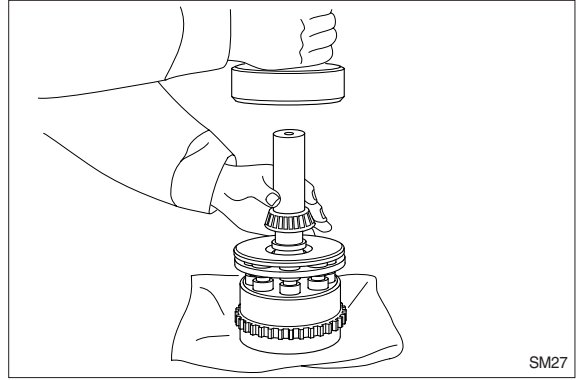

- ⑥ Apply loctite to bearing mounting area of inner race of cylinder block (3) lightly.

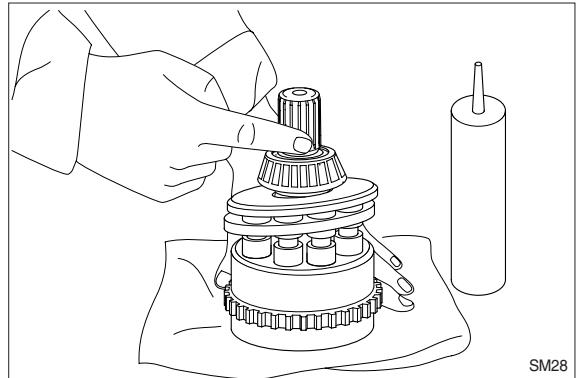

- ⑦ Assemble bushing (6) to cylinder block (3).

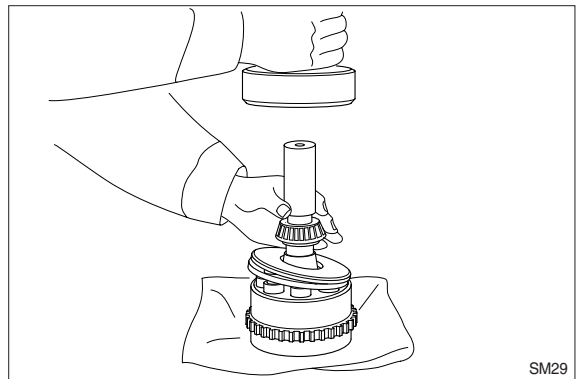

(3) Oil seal

Apply three bond of white color on outer surface of oil seal (2) and assemble and insert it.

- ※ Before assembling, lubricate lip of oil seal with grease.

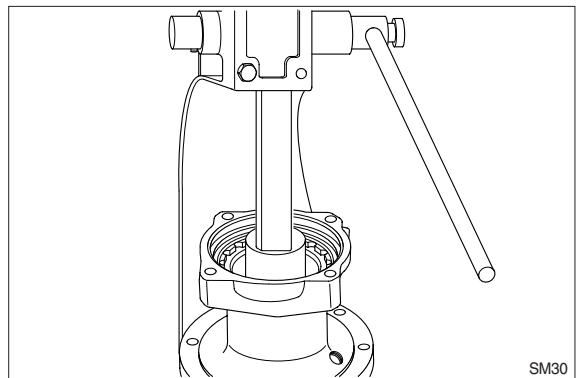

- (4) Assemble outer race of taper roller bearing (5) to motor housing (1).

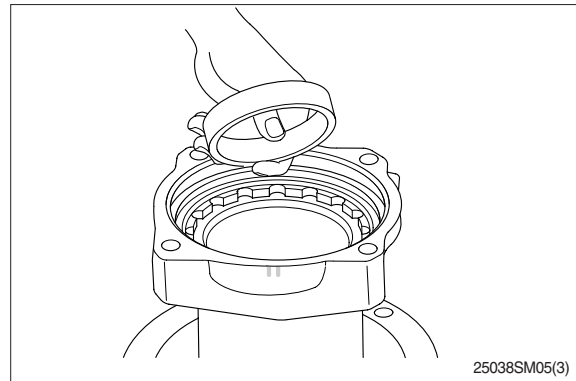

(5) Cylinder assembly

Hold end of cylinder assembly(3) with hands and assemble cylinder assembly to housing(1). Be careful to prevent damage of seal by spline of shaft.

- ※ When assemble cylinder assembly, spline shaft of cylinder is protruded from end of housing, therefore put pads with length 30~50mm under bottom of housing.

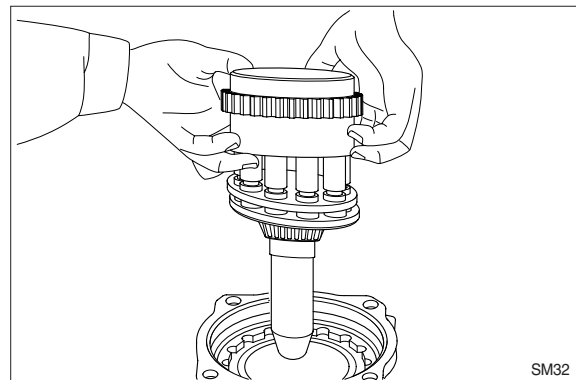

- (6) Assemble friction plate (26) and lining plate (27).

- ※ Lubricate specified hydraulic oil on each side.

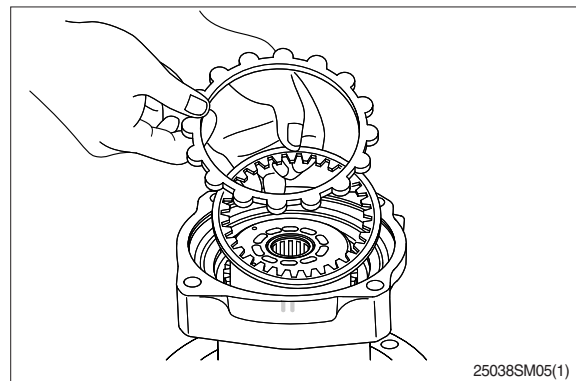

- (7) Insert O-rings (14,29) into housing (1) and piston (28).

- ※ Lubricate O-ring with grease.

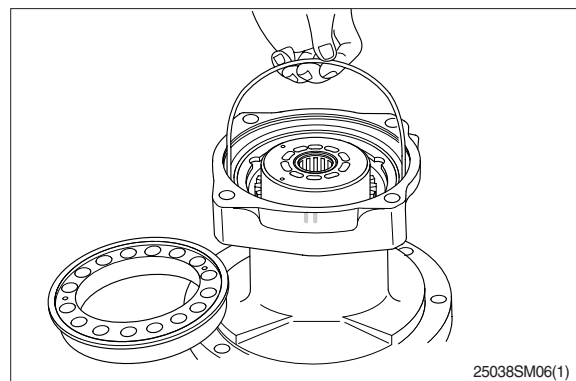

(8) Brake piston

Lubricate specified hydraulic oil on outer sliding face of piston (28) and assemble brake piston to housing (1).

- ※ It is too tight to assemble piston (10) because O-rings (14,29) are fitted, therefore it is recommended to push piston (28) horizontally by hands at once.

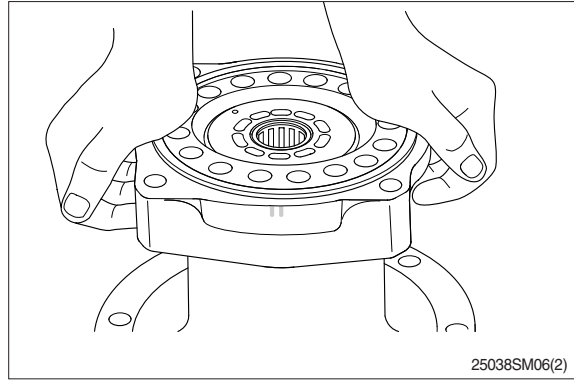

(9) Spring (30, brake unit)

Assemble spring (30) to piston (28) of brake unit.

- ※ Insert spring (30) into original position.

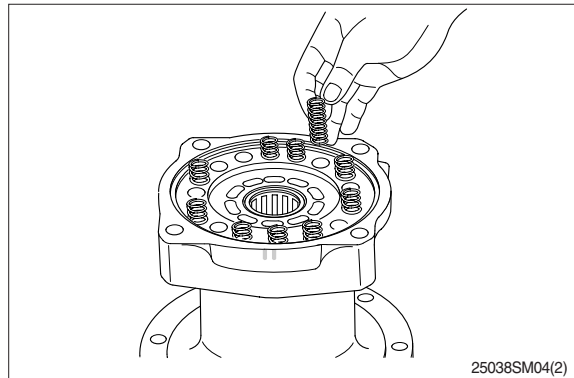

- (10) Lubricate locating pin for antirotation of valve plate (16) of cover (12) with grease sufficiently and install locating pin to housing.

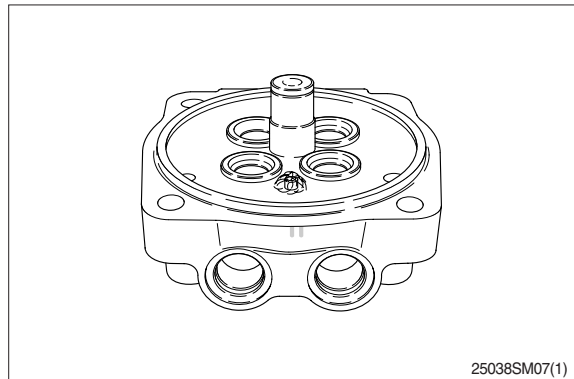

(11) Balance plate

Assemble valve plate (16) to cover (12).

- ※ Be cautious of assembling direction.

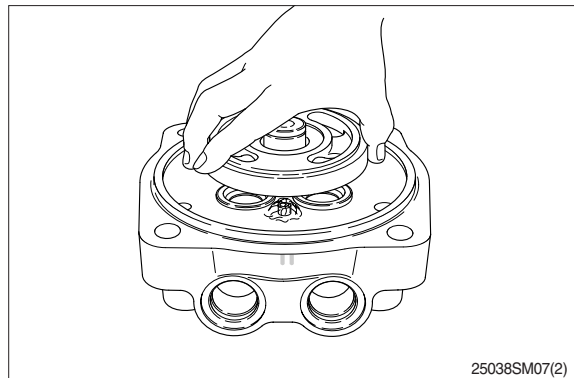

- (12) Assemble inner race of needle bearing (15) and shim (22) to cover (12).

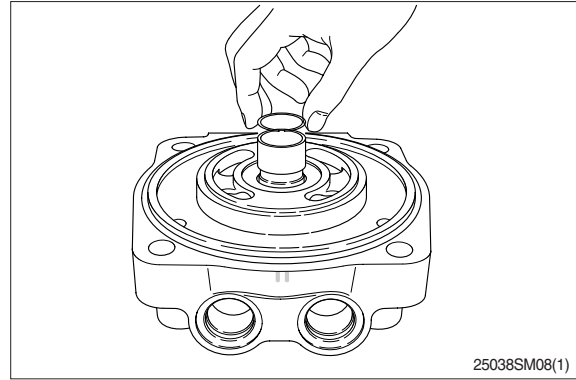

- (13) Assemble O-ring (29) to cover (12).
※ Lubricate O-ring with grease.

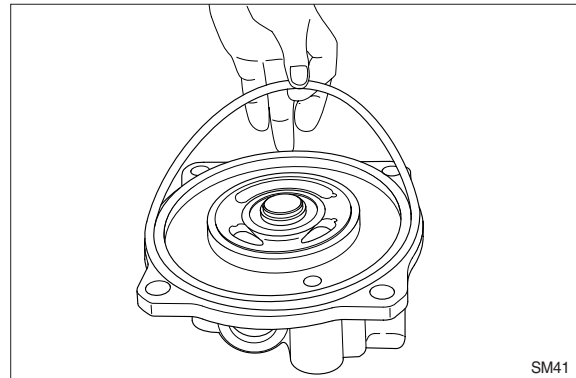

- (14) Apply three bond of white color to distinguish oil leakage from remaining oil in bolt hole of cover (12).

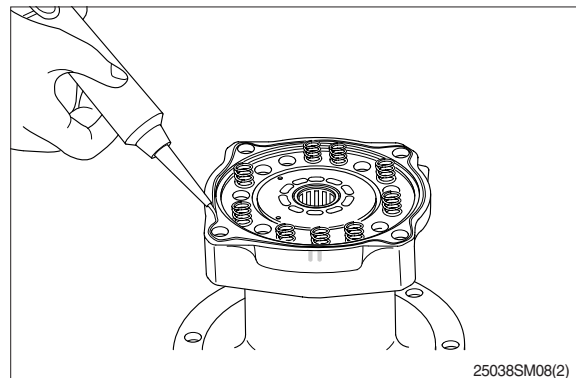

(15) Cover

Assemble cover (12) and valve plate (16) to housing (1) lightly, holding them up with hands.

- ※ When assembling, be careful not to detach valve plate (16) and bushing (6) from cover (12).
- ※ Fit matching marks on housing (1) and cover (12) made before disassembling.

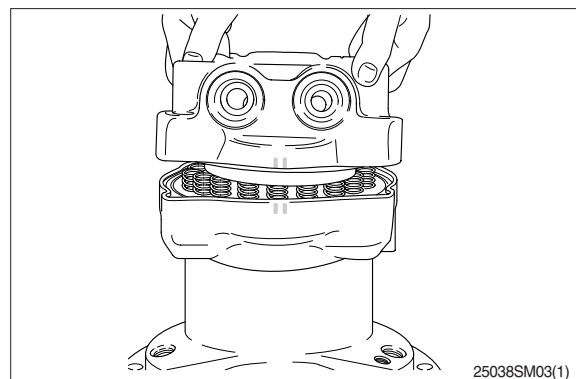

- (16) Tighten cover (12) and housing (1) with 12 mm hexagonal socket bolt (18).
- Tightening torque : 16 kgf · m (116 lbf · ft)

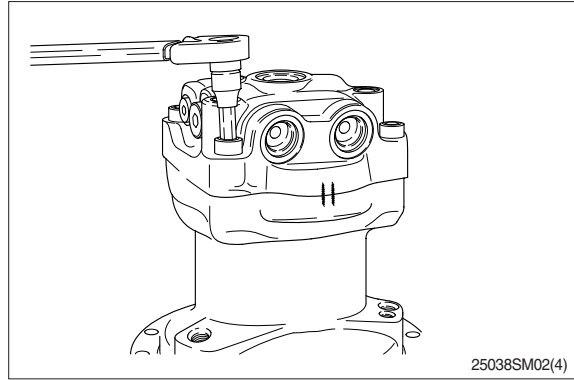

(17) Make up valve

- Assemble check(35) and spring(36) to cover(12) and tighten plug(37) with 14 mm hexagonal socket bolt.
- Tightening torque : 14 kgf · m (101 lbf · ft)

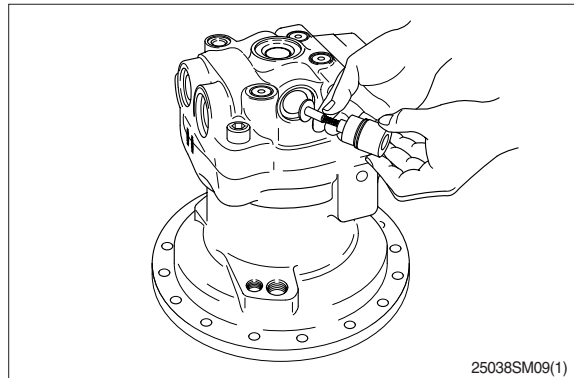

(18) Relief assembly

- Assemble relief valve assembly(17) to cover(12) with 14mm hexagonal socket bolt.
- Tightening torque : 8 kgf · m (58 lbf · ft)
- ※ Be cautious of assembling method.

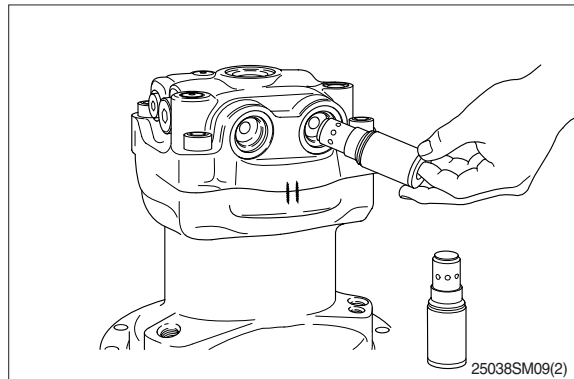

(19) Check of assembly

- Load pilot pressure of 20 kgf/cm² to brake release port after opening inlet and outlet port.
- Check if output shaft is rotated smoothly around torque of 0.5~1 kgf · m.
- If not rotated, disassemble and check.

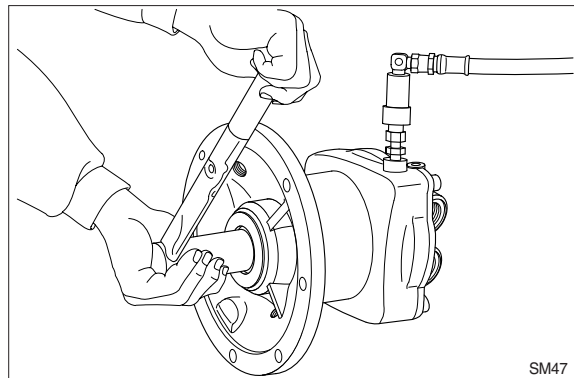

This completes assembly.

3. REMOVAL AND INSTALL OF REDUCTION GEAR

1) REMOVAL

- (1) Remove the swing motor assembly.
For details, see removal of swing motor assembly.
- (2) Sling reduction gear assembly (1) and remove mounting bolts (2).
- (3) Remove the reduction gear assembly.
 - Reduction gear device weight : 45 kg
(99 lb)



2) INSTALL

- (1) Carry out installation in the reverse order to removal.
 - Tightening torque : 10.5 kgf · m
(76 lbf · ft)

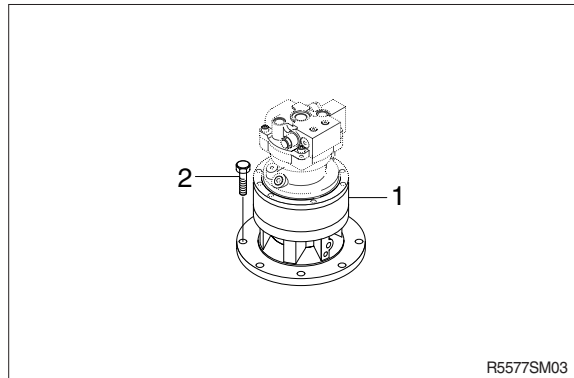

4. DISASSEMBLY AND ASSEMBLY OF REDUCTION GEAR

1) STRUCTURE

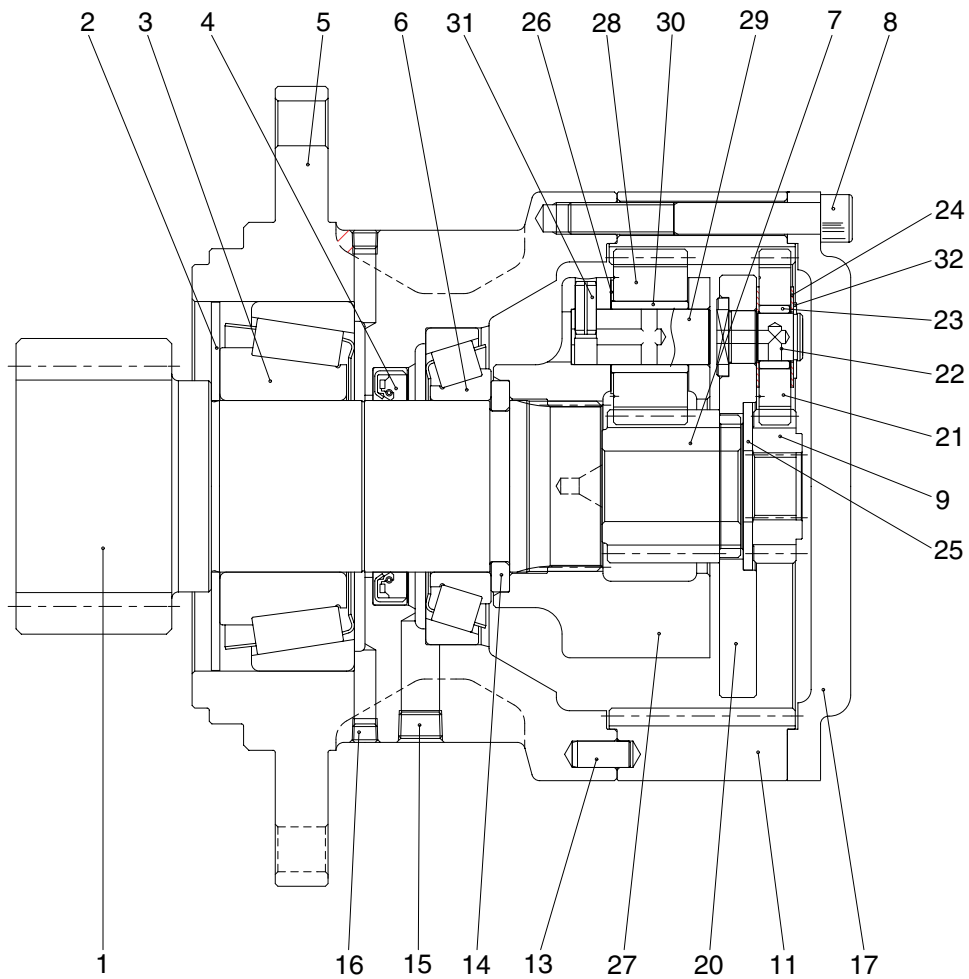

55W72SM02

1	Shaft	12	Carrier assy 2	23	Bushing 1
2	Bearing cover	13	Dowel pin	24	Thrust washer 1
3	Taper roller bearing	14	Collar	25	Thrust washer 3
4	Case	15	Plug	26	Thrust washer 2
5	Oil seal	16	Plug	27	Carrier assy 2
6	Taper roller bearing	17	Cover	28	Planet gear 2
7	Sun gear 2	18	Pipe	29	Pin 2
8	Socket bolt	19	Level gauge	30	Bushing 2
9	Sun gear 1	20	Carrier assy 1	31	Spring pin
10	Carrier assy 1	21	Planet gear 1	32	Snap ring
11	Ring gear	22	Pin 1	33	Thrust washer 4

2) DISASSEMBLY

- (1) Remove the plug (15) and drain out gear oil.

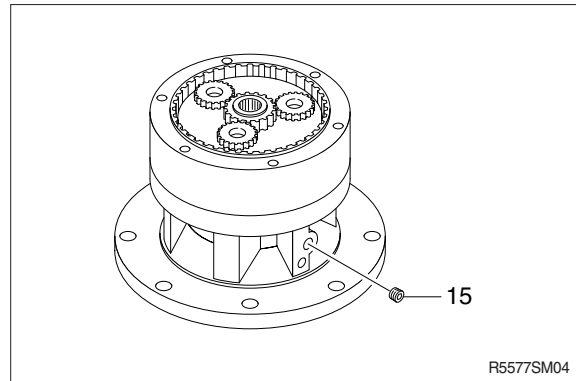

- (2) Remove the No.1 sun gear (9).

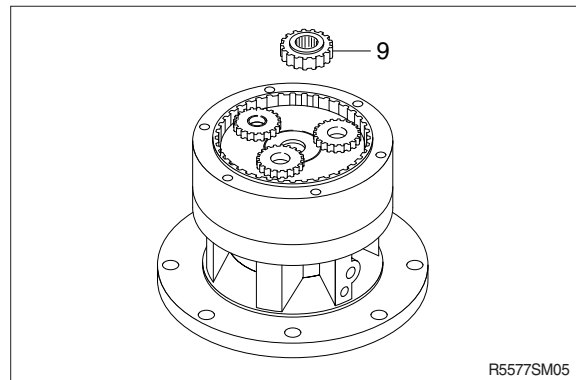

- (3) Remove the No.1 carrier sub-assembly (10) using the jig.

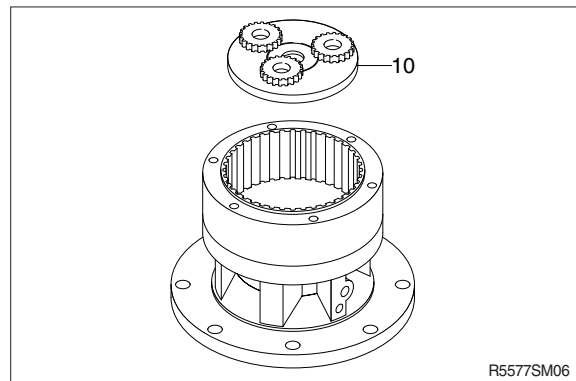

- (4) Remove the No.2 sun gear (7).

※ Pay attention to ensure the gear is not damaged during disassembling.

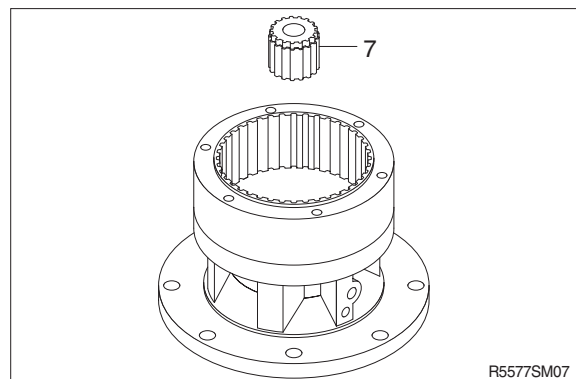

- (5) Remove the No.2 carrier sub assembly (12).

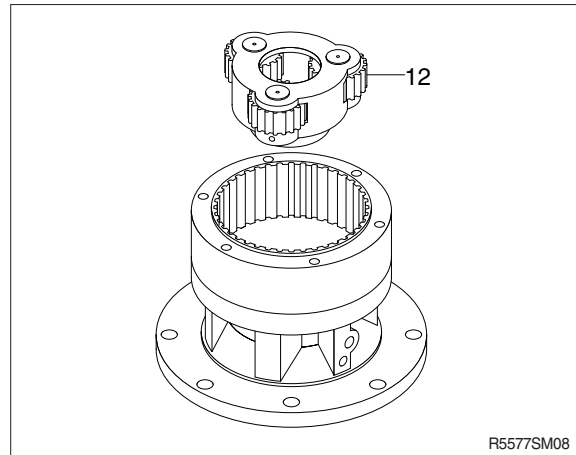

- (6) Remove the ring gear by the removal groove between the ring gear (11) and casing (4) by using jig.
Full out the knock pin (13).
Do not need to remove the knock pin (13) if it is not worn or damaged.

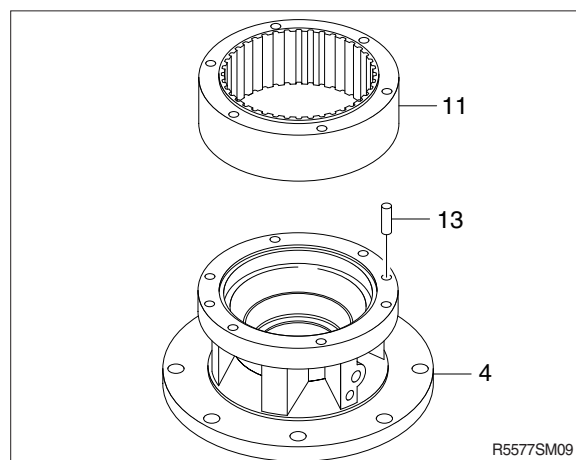

- (7) Put it on the working table with the drive shaft up.

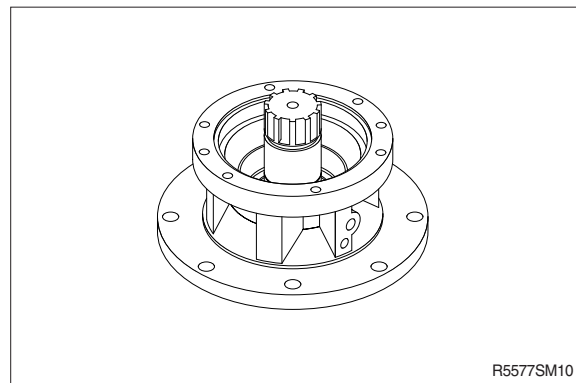

- (8) Disassemble the drive shaft (1) with bearing (3) by using jig.

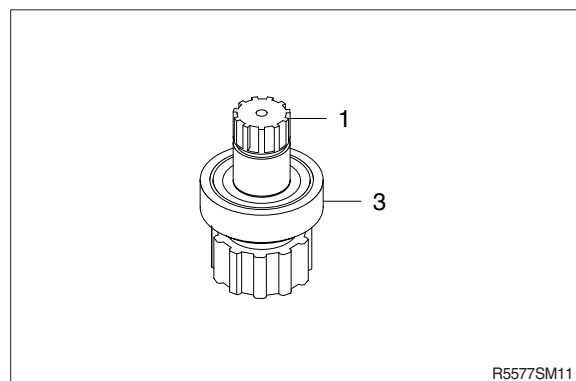

3) ASSEMBLING SWING REDUCTION GEAR

- (1) Place the case (4) on the reversing machine having the flange side of the case up.

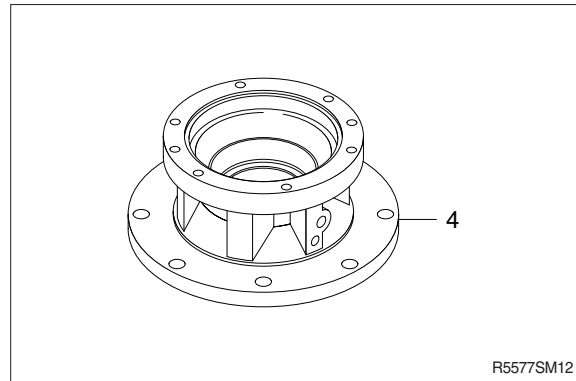

- (2) Install shaft assembly (1) into case (4).
※ Be sure to clean the case before install, using washing machine with the temperature of 80°C
※ Do not install shaft assembly by force.

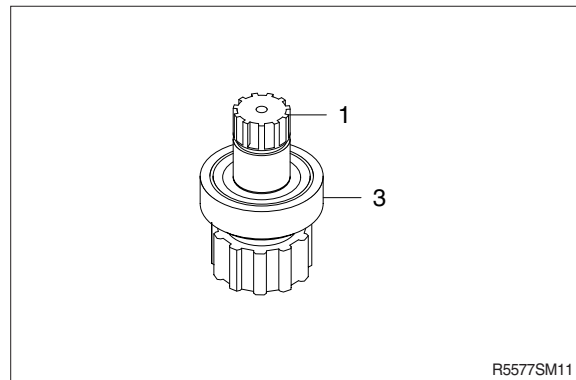

- (3) Reverse case and press to insert oil seal (5) by using pressing jig after spreading grease oil around the outside ring of the seal and bearing.
Coat grease oil slightly on the lip surface to prevent any scratch when installing.
※ Be sure to check by eye that the oil seal is seated completely after being installed.

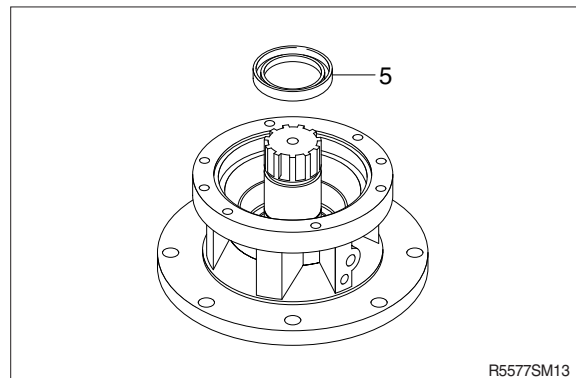

- (4) Clean the assembling surface of case and spread packing liquid (TH1105) as shown in figure.

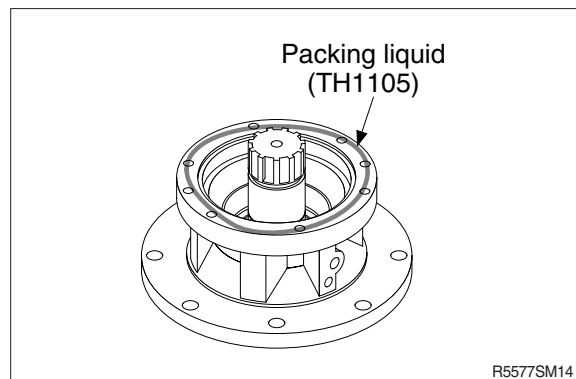

(5) Place ring gear (11) on the case by matching it with knock pin (13) hole.

(6) Insert 2 knock pins (13) by using jig.

※ Be sure to check the hole location of oil gage before inserting.

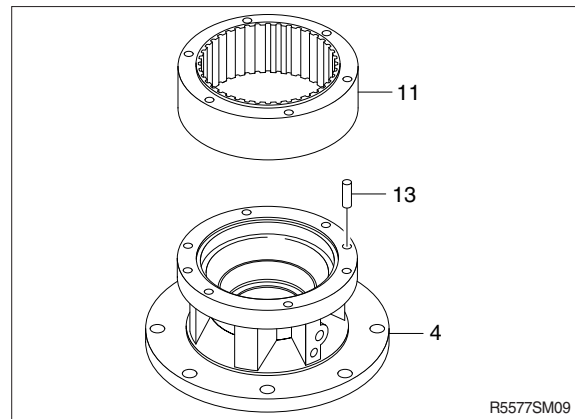

(7) Screw drain plug into drain plug (15) after winding sealing tape.

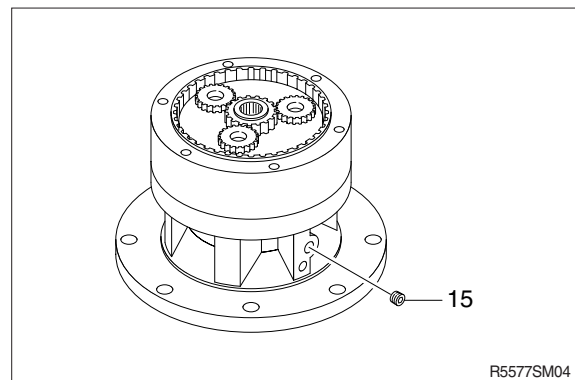

(8) Mount No.2 carrier assembly (12) in the case sub assembly and install bolts into 2 TAP holes (M6) as shown in figure.

※ Turn the carrier slowly by hand to adjust the matching holes when assembling.

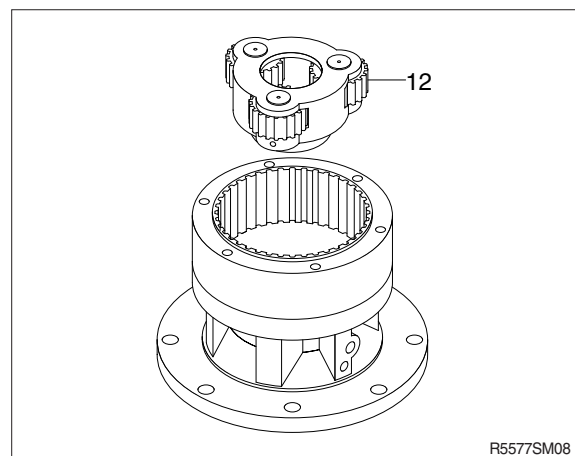

(9) Install No.2 sun gear (7).

※ Be sure to check the direction of sun gear (7) when assembling.

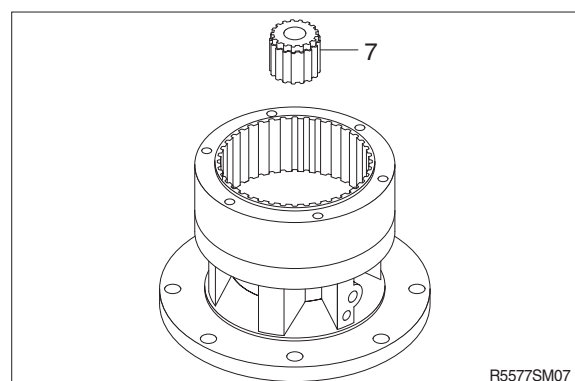

(10) Mount No.1 carrier assembly (10) in the case sub assembly and install bolts into 2 TAP holes (M6) as shown in figure.

※ Turn the carrier slowly by hand to adjust the matching holes when assembling.

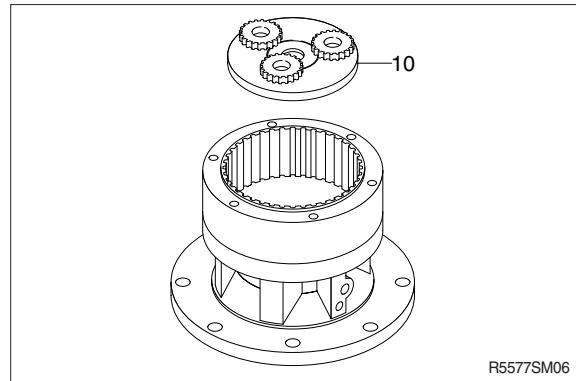

(11) Assemble No.1 sun gear (9).

