

SECTION 2 STRUCTURE AND FUNCTION

Group 1 Pump Device	2-1
Group 2 Main Control Valve	2-9
Group 3 Swing Device	2-31
Group 4 Travel Device	2-41
Group 5 RCV Lever	2-50

SECTION 2 STRUCTURE AND FUNCTION

GROUP 1 HYDRAULIC PUMP

1. GENERAL

This is a variable displacement double-piston pump for discharge with equal displacements from one cylinder block. This pump is so compact as to appear a single pump though this is actually a double pump.

Because this pump has one swash plate, the tilting angle is the same for two pumps. Tilting of the pump changes in response to the total pressure of P1 + P2. Namely, the output is controlled to the constant value so that the relationship between the discharge pressure and flow rate Q becomes constant, $(P1 + P2) \times Q = \text{Constant}$.

The third pump and pilot pump can be connected to the same shaft via a coupling.

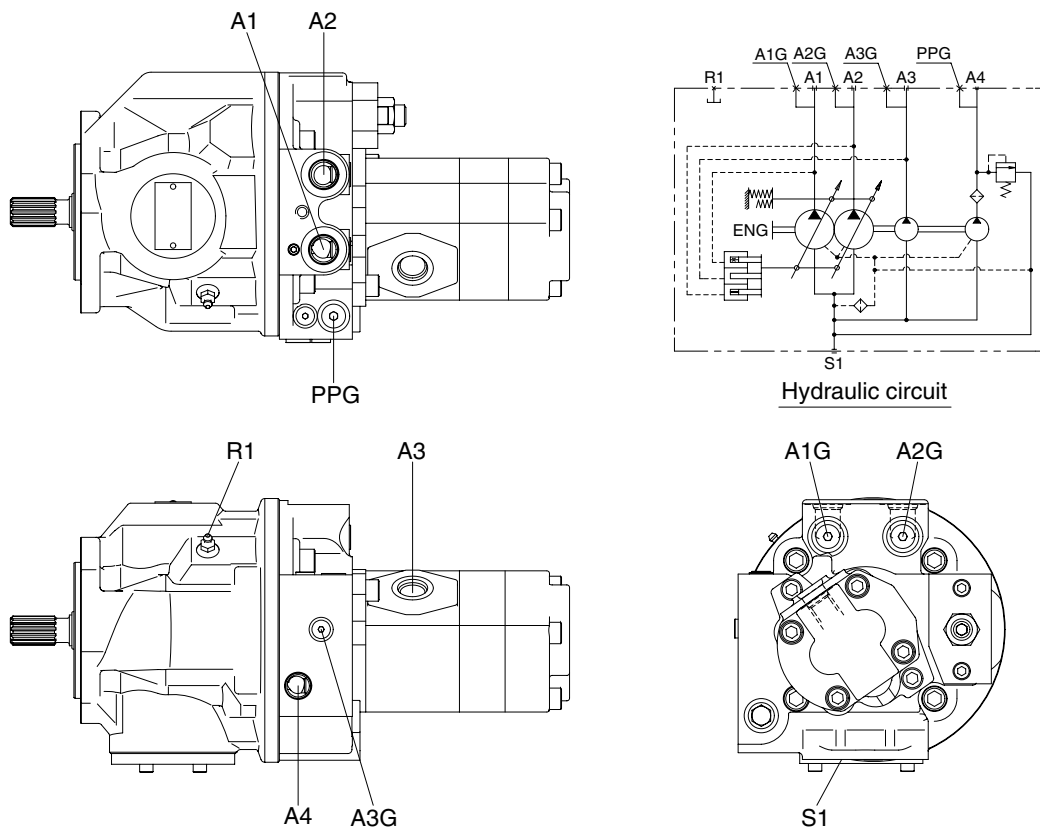

555C92MP01

Description of the ports

Port	Name	Bore
S1	Suction port	SAE 1 1/2 (standard)
A1, A2	Discharge port	PF 1/2
A3	Discharge port	PF 1/2
A4	Discharge port	PF 1/4
A1G, A2G	Gauge port	PF 1/4 With quick coupler
A3G	Gauge port	PF 1/8 With quick coupler
A4G	Gauge port	PF 1/4 With quick coupler
R1	Air bleeder port	M10 × 1.0 (with bleeder valve)

2. PRINCIPAL COMPONENTS AND FUNCTIONS

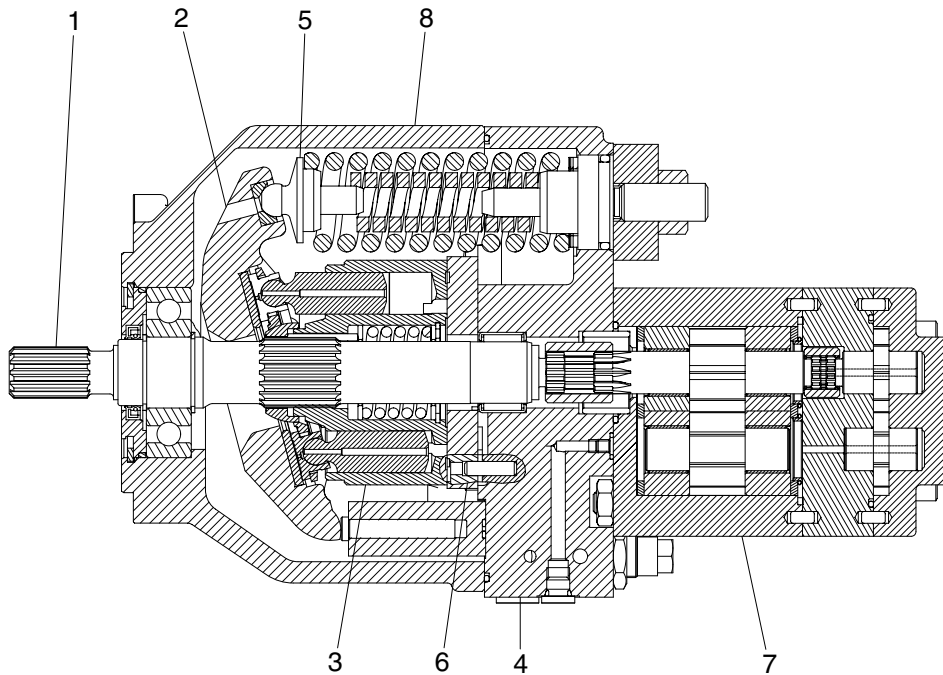

R5572SF02

- | | | | |
|---|--------------|---|----------------|
| 1 | Drive shaft | 5 | Control spring |
| 2 | Hanger | 6 | Control piston |
| 3 | Rotary group | 7 | Gear pump |
| 4 | Cover | 8 | Housing |

SPECIFICATIONS

- Capacity : $2 \times 27.5 + 18.3 + 4.5$ cc/rev
- Rated oil flow : $2 \times 55 + 36.6 + 9.0$ l /min
- Rated pressure : $3 \times 220 + 30$ kgf/cm²

This is a variable displacement double-piston pump for discharge with two equal displacements from one cylinder block. Because this is one rotary group, there is only one suction port.

The oil is divided into two equal flows by the control plate in the cover and directed to two discharge ports provided in the cover.

The discharge pressure directed to the control piston tilts the hanger by overcoming the spring force.

Since the piston stroke changes according to the tilting angle of the hanger, the flow can be changed.

The simultaneous tilting angle constant-output control method is employed.

The third pump and pilot pump can be connected to the same shaft via a coupling.

1) PRINCIPLE OF OPERATION

(1) Function of pump

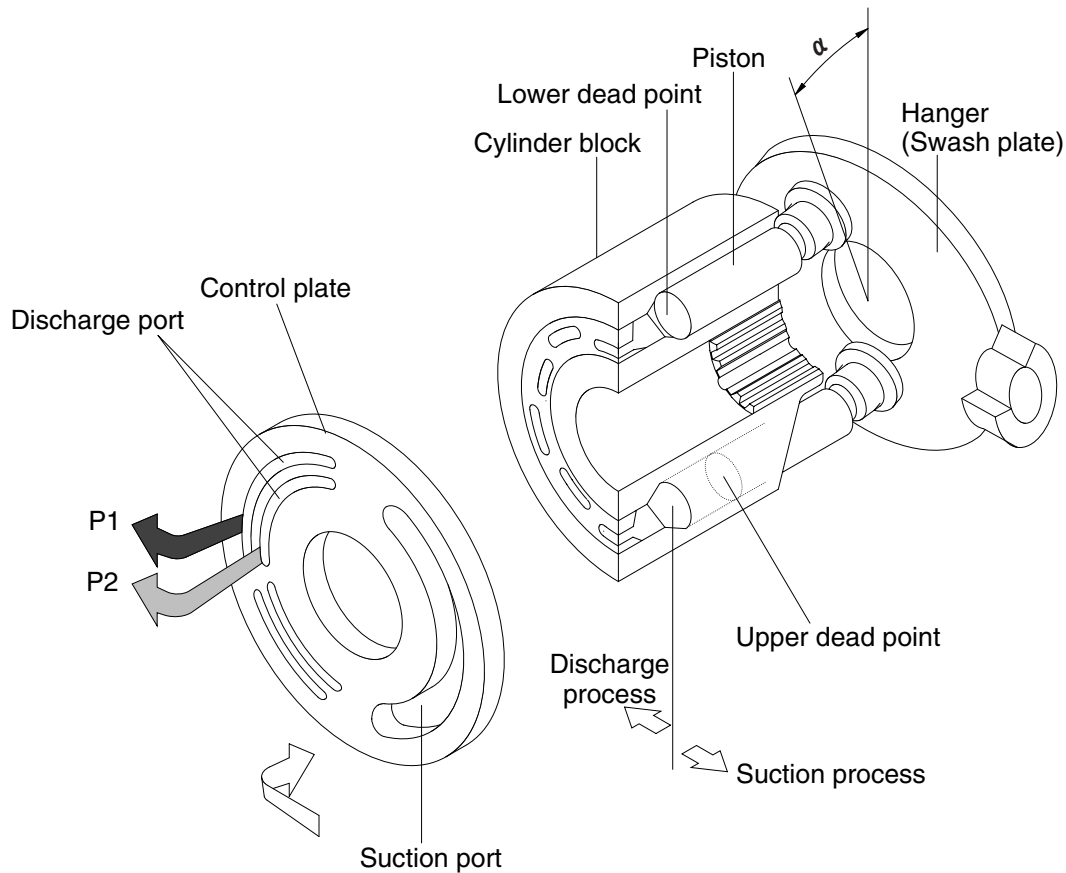

R5572SF03

The cylinder block is connected via spline and can rotate together with the drive shaft.

The piston assembled into the cylinder block performs reciprocal operation while following the swash plate on the hanger.

The piston moves in a direction to increase the displacement during a stroke from the lower to the upper dead points. The oil flows from the suction port via a port plate into the cylinder block (suction process).

During a stroke from the upper to the lower dead points, the piston moves in a direction to decrease the displacement. The oil is discharged to the discharge port (discharge process).

The displacement can be changed by changing the tilting of the hanger (swash plate).

The oil sucked through the port in the cylinder block is discharged from the discharge port in the port plate.

The oil sucked through the port on the outside of the cylinder block is discharged from the discharge port on the outside of the port plate.

2) CONTROL FUNCTIONS

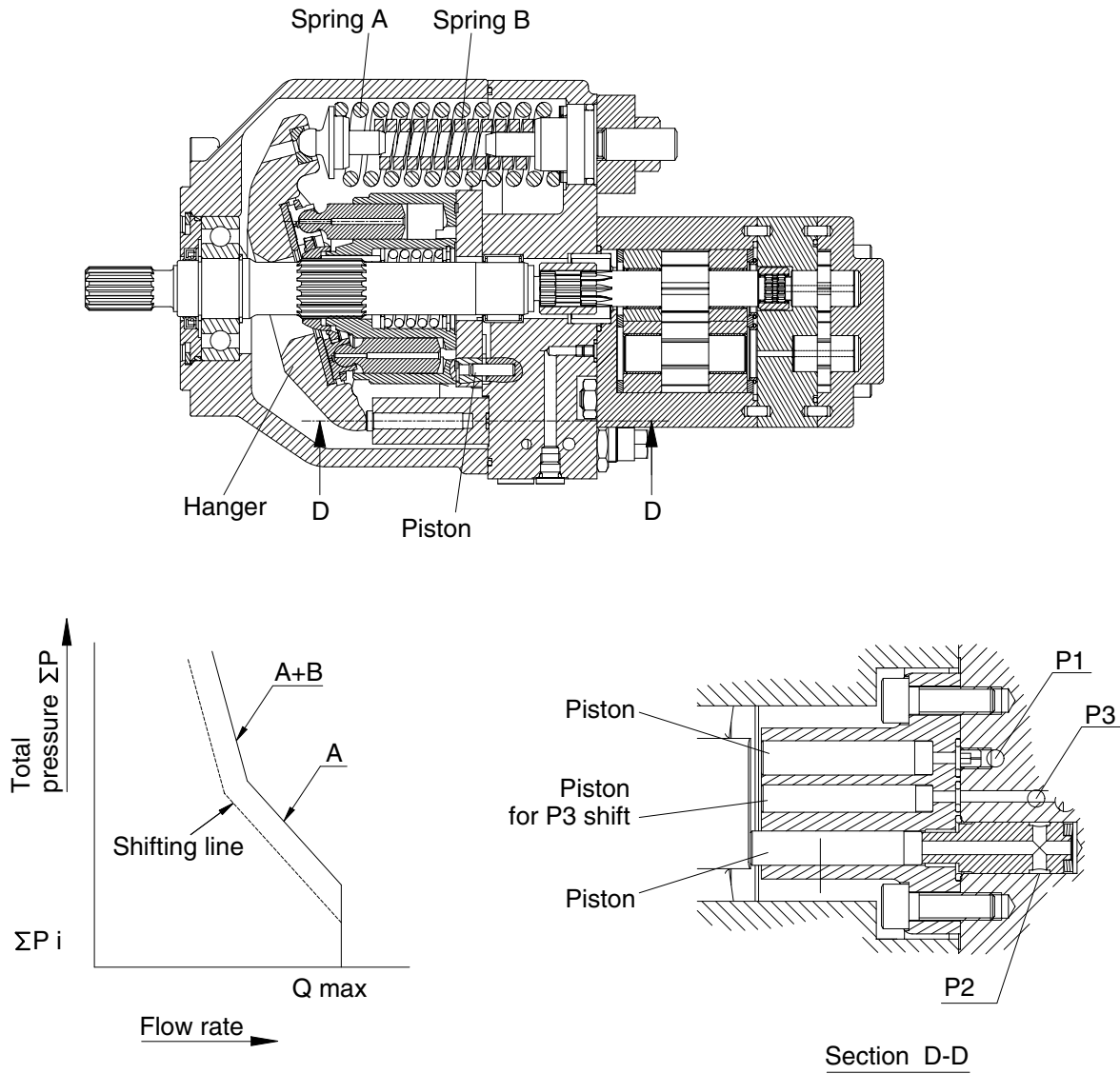

R5572SF04

The discharge pressures P1 and P2 are directed to the pistons of equal area act on the hanger. The spring is provided to act against the discharge pressure. When the oil pressure acting on the piston is less than the installation load of the spring A (outer spring), the hanger is fixed to the maximum tilting position. When the oil pressure acting on the piston exceeds the installation load of the spring A the hanger is tilted and kept tilted at a position where the oil pressure is balanced with the spring force. (region A in the middle of the figure above)

When the oil pressure acting on the piston rises further to reduce the tilting angle, the spring B which has been inactive up to now becomes active.

To overcome the spring force of two springs, the oil pressure must be higher and the shifting line becomes more steep. (regions A + B in the middle of the figure above)

When the P3 oil pressure acts on the shift piston, the control shifting line is shifted.

3) CONTROL / ADJUSTMENT PROCEDURE

- (1) Loosen the hexagonal nut.
- (2) Tighten or loosen the adjusting screw to set the power shifting line.

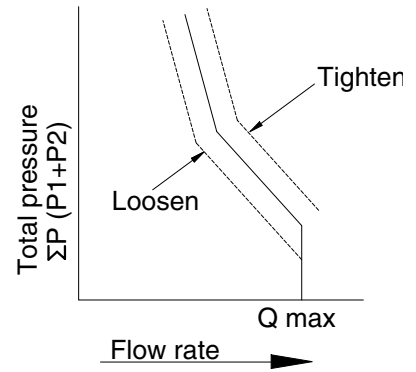
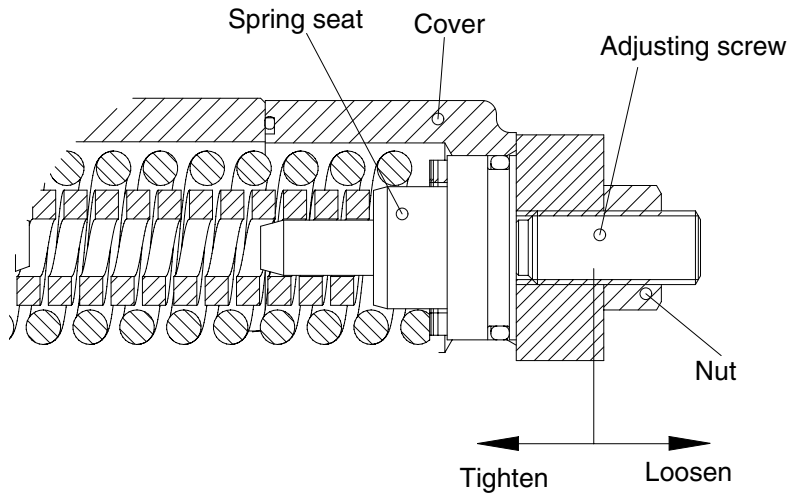

R5572SF05

3. ADJUSTMENT

This hydraulic pump has been set and inspected according to your specified input power and control. Readjustment of all the adjusting portions may lead to the loss of functions specified for each control and the pump proper may be excluded from the scope of guarantee. Never attempt operating the adjusting screw, etc.

4. INSTALLATION

- (1) Install the pump so that the input shaft becomes horizontal.
- (2) Install the pump in a position lower than the lowest oil level in the tank to allow continuous flow of the oil into the pump.
- (3) Since the pump is installed directly to the diesel engine, always use a flexible hose. Install the suction pipe firmly to prevent suction of an air.
- (4) Use the high-pressure type flexible hoses for the discharge ports P1 and P2.
- (5) After installation, fill the pump housing with the hydraulic oil.
- (6) Do not direct the external drain piping from within the oil.

5. DRIVE

- (1) Use a flexible coupling for connection to the motor.
- (2) Insert the coupling firmly onto the input shaft. Do not hammer the coupling during insertion.
- (3) The input shaft must rotate clockwise when viewed from the shaft end.

6. HYDRAULIC OIL

The hydraulic oil to be used must be a general petroleum, hydraulic oil or wear-resistant hydraulic oil (ISO 3448, VG 32 ~ 56 or equivalent).

The applicable viscosity range is as follows :

Maximum allowable viscosity : 1000 mm²/s

Minimum allowable viscosity : 10 mm²/s

Recommended viscosity range : 15 ~ 150 mm²/s

7. STARTING PROCEDURE

※ Before start up, check the following points and observe the cautions :

- (1) Check if the tank has been washed clean.
- (2) Check if the piping is clean and installed in such a manner as to prevent stress on the pump.
- (3) Check if the piping is connected correctly according to the piping (circuit) diagram.
- (4) Check if the joint and flange are correctly tightened.
- (5) Check if the joint between the motor and pump is correctly installed.
- (6) Check if the motor rotation direction agrees with the pump rotation direction.
- (7) Check if the specific hydraulic oil is supplied through the filter and filled in the tank to the specified position of the oil level gage.
- (8) Check if the filter has the specified filtration accuracy (10 μm or less).
- (9) Check if the filter has been installed correctly relative to the float direction.
- (10) Check if the pump housing is filled with oil.
- (11) Check if the control valve is set to the bypass position.
- (12) Start the motor. If necessary, carry out warm-up operation at low speed.
- (13) Check, without any load on the system, if the actuator operates correctly.

- (14) When the motor has reached the operation speed, check the operation while applying the load to the actuator.
- (15) Check the monitoring or measuring instrument if installed.
- (16) Check the noise level.
- (17) Check the oil level in the tank. Supply the oil. If required.
- (18) Check the setting of the pressure control valve while applying the load to the actuator.
- (19) Check the parts for any leakage.
- (20) Stop the motor.
- (21) Retighten all the bolts and plugs even when they have proved to be free from Leakage.
(Be sure to remove the pressure from the circuit before retightening.)
- (22) Check the oil level in the tank.
- (23) Check if the pump and actuator function correctly.
- (24) Irregular operation of the actuator indicates that an air is left still in the circuit. When the air is bled completely from the circuit, all the parts operate smoothly without any irregular movement and there is no bubble in the oil of the tank.
- (25) Check the oil temperature.
- (26) Stop the motor.
- (27) Check the filter if the element is fouled.
- (28) If the element is heavily fouled, carry out flashing in the circuit.

※ To prevent damage to the pump, be sure to observe the following cautions during the operation which may allow entry of the actuator, hydraulic oil change, etc :

- (1) After oil supply, fill the pump housing with the hydraulic oil.
- (2) Start the pump with the speed of 1000 rpm or less and take care not to allow the oil level to lower below the specified level of the oil level gauge.
- (3) When bleeding an air from the hydraulic circuit, keep the motor speed at 1000 rpm or less. Operate each actuator for three or more cycles and carry out idling for 5 minutes or more.

8. MAINTENANCE

The maintenance of this hydraulic pump is limited mainly to the tank, in particular, the hydraulic oil change.

Since the maintenance interval varies depending on respective operation and use conditions, the cautions described below for the users should be for reference only.

(1) Checking the filter

- ① Every day for the initial period after start up.
- ② Once a week when the operation becomes stable.
- ③ Once a month when the operation hours exceed about 100 hours.

※ When any part of the hydraulic system is changed (e.g., assembling of an additional part, change and repair of the piping), check the filter newly as in the case of startup.

(2) Changing the filter

- ① After startup
- ② After 500 hours of operation
- ③ Every 500 hours of operation after that, and each time the hydraulic oil is changed or the failure occurs. If any abnormal fouling of the filter is observed during daily check up to the first filter change after startup, find out the cause.

In this case, do not extend the check and filter change intervals to 500 hours.

※ The paper filter can not be cleaned. Change the filter as a whole.

(3) Changing the hydraulic oil

- ① After 2000 hours of operation.
- ② Every 2000 hours of operation or once a year after that.

The change interval may have to be shortened depending on the degree of fouling and the thermal load condition of the hydraulic oil.

If the hydraulic oil is not appropriate and need be changed, pay attention to the following points :

Be sure to control the oil temperature below the highest temperature and above the lowest temperature during operation in winter and summer.

Pay attention to the following points during change of the hydraulic oil :

- Change the hydraulic oil as a whole quantity.
- Do not allow dust to mix into the circuit.
- Clean the tank inside.
- Supply the oil through the filter.

(4) Checking for the oil leakage

- ① Daily during the initial period after startup.
- ② Once a week when the operation becomes stable.

(5) Checking the temperature

- ① Monitor the temperature continuously.
- ② When the viscosity is above the allowable value because of low hydraulic oil temperature, warm-up operation is necessary.

Start the motor with the speed set to about one half of the rated speed, then operate the actuator under the load for a short period.

When the oil temperature is below the allowable ambient temperature, it is necessary to preheat the oil tank before start of the motor.

Take care not to allow the hydraulic oil temperature to exceed +90°C