

# GROUP 2 SPECIFICATIONS

## 1. MAJOR COMPONENT

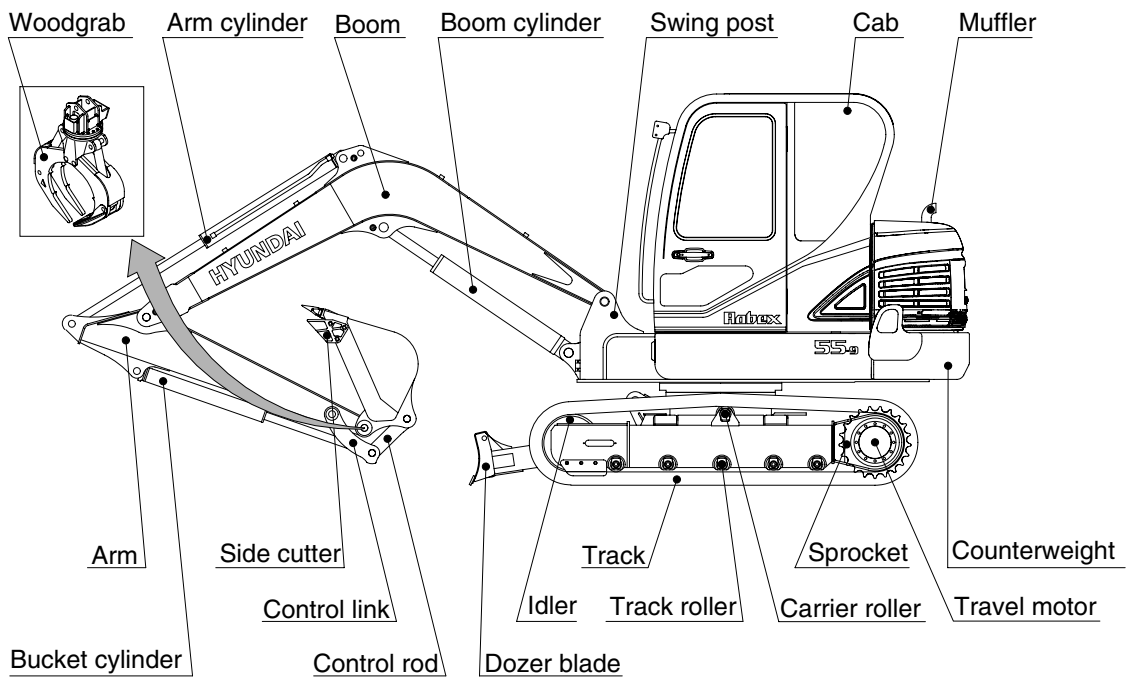
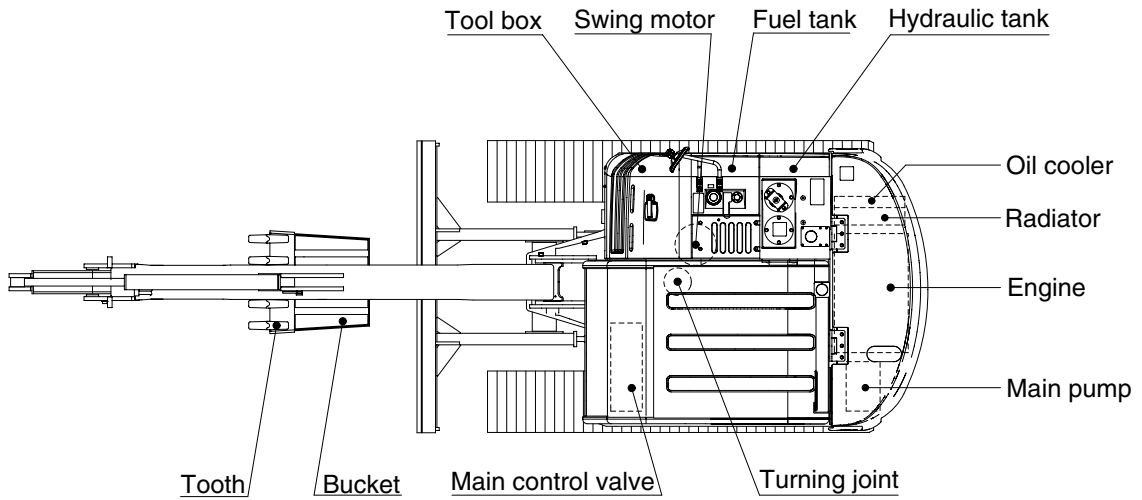

5592SP01A

## 2. SPECIFICATIONS

### 1) 3.0 m ( 9'10" ) MONO BOOM, 1.6 m ( 5' 3" ) ARM, WITH BOOM SWING SYSTEM

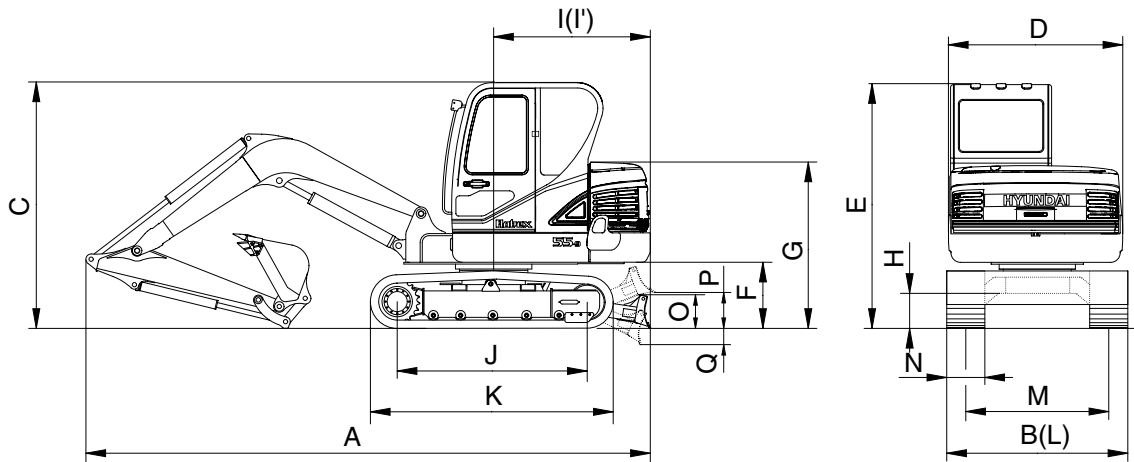

5592SP02

Description		Unit	Specification
Operating weight		kg (lb)	5650 (12460)
Bucket capacity (SAE heaped), standard		m <sup>3</sup> (yd <sup>3</sup> )	0.18 (0.24)
Overall length	A	mm (ft-in)	5900 (19' 4")
Overall width, with 380 mm shoe	B		1920 (6' 4")
Overall height	C		2550 (8' 4")
Superstructure width	D		1850 (6' 1")
Overall height of cab	E		2550 (8' 4")
Ground clearance of counterweight	F		690 (2' 3")
Engine cover height	G		1690 (5' 7")
Minimum ground clearance	H		380 (1' 3")
Rear-end distance	I		1650 (5' 5")
Rear-end swing radius	I'		1650 (5' 5")
Distance between tumblers	J		1990 (6' 6")
Undercarriage length	K		2530 (8' 4")
Undercarriage width	L		1880 (6' 2")
Track gauge	M		1500 (4' 11")
Track shoe width, standard	N		380 (15")
Height of blade	O		350 (1' 2")
Ground clearance of blade up	P		410 (1' 4")
Depth of blade down	Q		560 (1' 10")
Travel speed (low/high)			km/hr (mph)
Swing speed		rpm	9.3
Gradeability		Degree (%)	35 (70)
Ground pressure (380 mm shoe)		kgf/cm <sup>2</sup> (psi)	0.33 (4.69)
Max traction force		kg (lb)	5300 (11680)

### 3. WORKING RANGE

#### 1) 3.0 m (9' 10") MONO BOOM WITH BOOM SWING SYSTEM

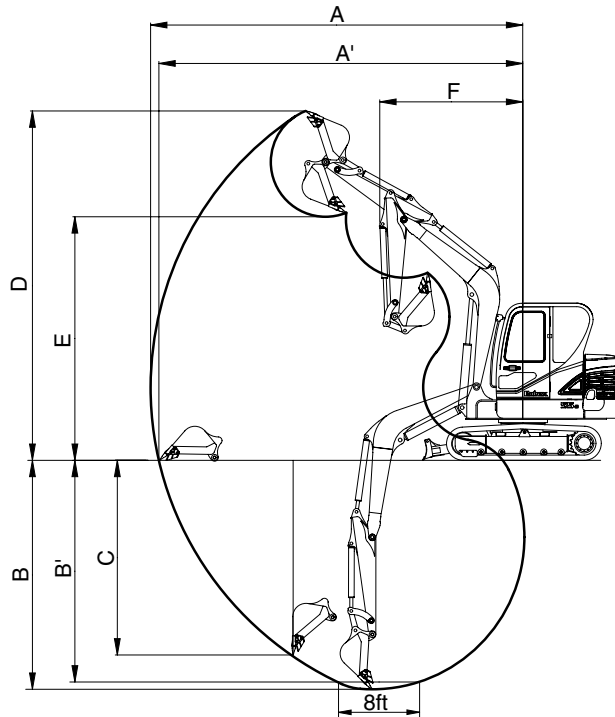

5592SP03

Description		1.6 m (5' 3") Arm
Max digging reach	A	6150 mm (25' 5")
Max digging reach on ground	A'	6010 mm (24' 11")
Max digging depth	B	3820 mm (16' 2")
Max digging depth (8ft level)	B'	3420 mm (15' 4")
Max vertical wall digging depth	C	3200 mm (15' 3")
Max digging height	D	5780 mm (26' 7")
Max dumping height	E	4050 mm (18' 7")
Min swing radius	F	2350 mm ( 8' 8")
Boom swing radius (left/right)		80°/50°
Bucket digging force	SAE	37.7 kN
		3850 kgf
		8490 lbf
	ISO	42.4 kN
		4330 kgf
		9550 lbf
Arm crowd force	SAE	28.4 kN
		2900 kgf
		6390 lbf
	ISO	31.9 kN
		3260 kgf
		7190 lbf











#### 4. WEIGHT

Item	kg	lb
Upperstructure assembly	2710	5970
Main frame weld assembly	600	1320
Engine assembly	280	620
Main pump assembly	30	70
Main control valve assembly	40	90
Swing motor assembly	80	180
Hydraulic oil tank assembly	90	200
Fuel tank assembly	60	130
Boom swing post	110	240
Counterweight	230	510
Cab assembly	350	770
Lower chassis assembly	2150	4740
Track frame weld assembly	700	1540
Swing bearing	90	200
Travel motor assembly	80	180
Turning joint	30	70
Track recoil spring	20	45
Idler & tension body	60	130
Carrier roller	10	20
Track roller	10	20
Sprocket	20	40
Track-chain assembly (380 mm standard triple grouser shoe)	320	710
Dozer blade assembly	210	460
Front attachment assembly (3.0 m boom,1.6 m arm, 0.18 m <sup>3</sup> SAE heaped bucket)	790	1740
3.0 m boom assembly	240	530
1.6 m arm assembly	130	290
0.18 m <sup>3</sup> SAE heaped bucket	170	370
Boom cylinder assembly	70	155
Arm cylinder assembly	60	130
Bucket cylinder assembly	35	80
Bucket control link assembly	40	90
Dozer cylinder assembly	40	90
Boom swing cylinder assembly	40	90

## 5. LIFTING CAPACITIES



1) 3.0 m (9' 10") boom, 1.6 m (5' 3") arm equipped with 0.18 m<sup>3</sup> (SAE heaped) bucket and 380 mm (15") triple grouser shoe, the dozer blade down with 230 kg (510 lb) counterweight.











-  : Rating over-front
-  : Rating over-side or 360 degree

Load point height		Load radius								At max. reach		
		2.0 m (6.6 ft)		3.0 m (9.8 ft)		4.0 m (13.1 ft)		5.0 m (16.4 ft)		Capacity		Reach
												m (ft)
5.0 m (16.4 ft)	kg									*950	*950	4.12 (13.5)
	lb									*2090	*2090	
4.0 m (13.1 ft)	kg					*1020	*1020			*980	780	5.08 (16.7)
	lb					*2250	*2250			*2160	1720	
3.0 m (9.8 ft)	kg					*1090	*1090			*1010	650	5.60 (18.4)
	lb					*2400	*2400			*2230	1430	
2.0 m (6.6 ft)	kg	*3050	*3050	*1690	*1690	*1320	1100	*1170	760	*1050	590	5.84 (19.2)
	lb	*6720	*6720	*3730	*3730	*2910	2430	*2580	1680	*2310	1300	
1.0 m (3.3 ft)	kg			*2360	1610	*1600	1040	*1280	740	*1100	580	5.85 (19.2)
	lb			*5200	3550	*3530	2290	*2820	1630	*2430	1280	
Ground Line	kg	*2350	*2350	*2700	1540	*1790	1000	*1350	720	*1140	610	5.63 (18.5)
	lb	*5180	*5180	*5950	3400	*3950	2200	*2980	1590	*2510	1340	
-1.0 m (-3.3 ft)	kg	*3600	3020	*2670	1530	*1800	990			*1180	700	5.13 (16.8)
	lb	*7940	6660	*5890	3370	*3970	2180			*2600	1540	
-2.0 m (-6.6 ft)	kg	*3770	3060	*2300	1540					*1140	960	4.23 (13.9)
	lb	*8310	6750	*5070	3400					*2510	2120	
-3.0 m (-9.8 ft)	kg	*2040	*2040									
	lb	*4500	*4500									

- Note
1. Lifting capacity are based on SAE J1097 and ISO 10567.
  2. Lifting capacity of the ROBEX series does not exceed 75% of tipping load with the machine on firm, level ground or 87% of full hydraulic capacity.
  3. The load point is a hook located on the back of the bucket.
  4. \*indicates load limited by hydraulic capacity.

2) 3.0 m ( 9'10") boom, 1.6 m ( 5' 3") arm equipped with 0.18 m<sup>3</sup> (SAE heaped) bucket and 380 mm (15") triple grouser shoe, the dozer blade up with 230 kg (510 lb) counterweight.

-  : Rating over-front
-  : Rating over-side or 360 degree

Load point height		Load radius								At max. reach		
		2.0 m (6.6 ft)		3.0 m (9.8 ft)		4.0 m (13.1 ft)		5.0 m (16.4 ft)		Capacity		Reach
												m (ft)
5.0 m (16.4 ft)	kg									*950	*950	4.12
	lb									*2090	*2090	(13.5)
4.0 m (13.1 ft)	kg					*1020	*1020			*980	740	5.08
	lb					*2250	*2250			*2160	1630	(16.7)
3.0 m (9.8 ft)	kg					*1090	1080			890	610	5.60
	lb					*2400	2380			1960	1340	(18.4)
2.0 m (6.6 ft)	kg	*3050	*3050	*1690	1630	*1320	1030	1040	710	810	550	5.84
	lb	*6720	*6720	*3730	3590	*2910	2270	2290	1570	1790	1210	(19.2)
1.0 m (3.3 ft)	kg			2250	1510	1430	980	1010	690	800	540	5.85
	lb			4960	3330	3150	2160	2230	1520	1760	1190	(19.2)
Ground Line	kg	*2350	*2350	2170	1440	1390	940	990	670	840	570	5.63
	lb	*5180	*5180	4780	3170	3060	2070	2180	1480	1850	1260	(18.5)
-1.0 m (-3.3 ft)	kg	*3600	2780	2150	1420	1370	930			970	660	5.13
	lb	*7940	6130	4740	3130	3020	2050			2140	1460	(16.8)
-2.0 m (-6.6 ft)	kg	*3770	2830	2170	1440					*1140	900	4.23
	lb	*8310	6240	4780	3170					*2510	1980	(13.9)
-3.0 m (-9.8 ft)	kg	*2040	*2040									
	lb	*4500	*4500									

## 6. BUCKET SELECTION GUIDE

### 1) GENERAL BUCKET

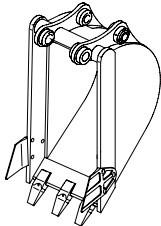
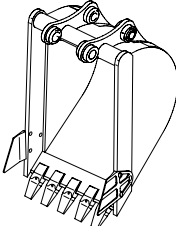
	
<p>0.07m<sup>3</sup> SAE heaped bucket</p>	<p>0.18 m<sup>3</sup> SAE heaped bucket</p>

Capacity		Width		Weight	Recommendation
SAE heaped	CECE heaped	Without side cutter	With side cutter		3.0 m (9' 10") boom
0.07 m <sup>3</sup> (0.09 yd <sup>3</sup> )	0.06 m <sup>3</sup> (0.08 yd <sup>3</sup> )	315 mm (12.4")	360 mm (14.2")	115 kg (255 lb)	1.6 m (5' 3") arm
0.18 m <sup>3</sup> (0.24 yd <sup>3</sup> )	0.15 m <sup>3</sup> (0.20 yd <sup>3</sup> )	670 mm (26.4")	740 mm (29.1")	170 kg (375 lb)	Applicable for materials with density of 1600 kgf/m <sup>3</sup> (2700 lb/yd <sup>3</sup> ) or less

## 7. UNDERCARRIAGE

### 1) TRACKS

X-leg type center frame is integrally welded with reinforced box-section track frames. The design includes dry tracks, lubricated rollers, idlers, sprockets, hydraulic track adjusters with shock absorbing springs and assembled track-type tractor shoes with triple grousers.

### 2) TYPES OF SHOES

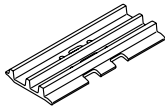
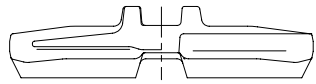
Model	Shapes		Triple grouser	
				
R55-9	Shoe width	mm (in)	380 (15)	400 (16)
	Operating weight	kg (lb)	5450 (12020)	5450 (12020)
	Ground pressure	kgf/cm <sup>2</sup> (psi)	0.33 (4.69)	0.33 (4.69)
	Overall width	mm (ft-in)	1880 (6' 2")	1900 (6' 3")

### 3) NUMBER OF ROLLERS AND SHOES ON EACH SIDE

Item	Quantity
Carrier rollers	1 EA
Track rollers	5 EA
Track shoes	40 EA

## 8. SPECIFICATIONS FOR MAJOR COMPONENTS

### 1) ENGINE

Item	Specification
Model	Yanmar 4TNV98-EPHYBU
Type	4-cycle diesel engine, low emission
Cooling method	Water cooling
Number of cylinders and arrangement	4 cylinders, in-line
Firing order	1-3-4-2
Combustion chamber type	Direct injection type
Cylinder borexstroke	98 × 110 mm (3.85" × 4.33")
Piston displacement	3319 cc (203 cu in)
Compression ratio	18.5 : 1
Rated gross horse power (SAE J1995)	57.8 Hp at 2400 rpm (42.5 kW at 2400 rpm)
Maximum torque at 1550 rpm	20.5 kgf · m (148 lbf · ft)
Engine oil quantity	11.6 l (3.1 U.S. gal)
Dry weight	270 kg (595 lb)
High idling speed	2400+50 rpm
Low idling speed	1050 ± 100 rpm
Rated fuel consumption	175.6 g/Hp · hr at 2400 rpm
Starting motor	12 V-3.0 kW
Alternator	12 V-80 A
Battery	1 × 12 V × 100 Ah

### 2) MAIN PUMP

Item	Specification
Type	Variable displacement tandem axis piston pumps
Capacity	2 × 27.5 cc/rev
Maximum pressure	220 kgf/cm <sup>2</sup> (3130 psi)
Rated oil flow	2 × 55 l /min (14.5 U.S. gpm / 12.1 U.K. gpm)
Rated speed	2000 rpm

### 3) GEAR PUMP

Item	Specification
Type	Fixed displacement gear pump single stage
Capacity	18.3 cc/rev
Maximum pressure	220/30 kgf/cm <sup>2</sup> (3130/430 psi)
Rated oil flow	36.6/9.0 l /min (9.7/2.4 U.S. gpm / 8.0/2.0 U.K. gpm)

### 4) MAIN CONTROL VALVE

Item	Specification
Type	Sectional, 9 spools+1 option
Operating method	Hydraulic pilot system+Mechanical control system
Main relief valve pressure	220 kgf/cm <sup>2</sup> (3130 psi)
Overload relief valve pressure	240 kgf/cm <sup>2</sup> (3410 psi)

[ ]: Power boost

### 5) SWING MOTOR

Item	Specification
Type	Fixed displacement axial piston motor
Capacity	32.3 cc/rev
Relief pressure	220 kgf/cm <sup>2</sup> (3130 psi)
Braking system	Automatic, spring applied hydraulic released
Braking torque	14 kgf · m (101 lbf · ft)
Brake release pressure	20~40 kgf/cm <sup>2</sup> (284~570 psi)
Reduction gear type	2 - stage planetary

### 6) TRAVEL MOTOR

Item	Specification
Type	Variable displacement axial piston motor
Relief pressure	220 kgf/cm <sup>2</sup> (3130 psi)
Reduction gear type	2-stage planetary
Braking system	Automatic, spring applied hydraulic released
Brake release pressure	9 kgf/cm <sup>2</sup> (128 psi)
Braking torque	8.4 kgf · m (61 lbf · ft)

## 7) CYLINDER

Item		Specification
Boom cylinder	Bore dia × Rod dia × Stroke	∅ 110 × ∅ 65 × 715 mm
	Cushion	Extend only
Arm cylinder	Bore dia × Rod dia × Stroke	∅ 90 × ∅ 55 × 850 mm
	Cushion	Extend and retract
Bucket cylinder	Bore dia × Rod dia × Stroke	∅ 80 × ∅ 50 × 660 mm
	Cushion	Extend only
Dozer blade	Bore dia × Rod dia × Stroke	∅ 110 × ∅ 60 × 219 mm
	Cushion	Extend only

※ Discoloration of cylinder rod can occur when the friction reduction additive of lubrication oil spreads on the rod surface.

※ Discoloration does not cause any harmful effect on the cylinder performance.

## 8) SHOE

Item	Width	Ground pressure	Link quantity	Overall width
R55-9	380 mm (15")	0.33 kgf/cm <sup>2</sup> (4.69 psi)	40	1880 mm (6' 2")

## 9) BUCKET

Item		Capacity		Tooth quantity	Width	
		SAE heaped	CECE heaped		Without side cutter	With side cutter
R55-9	STD	0.18 m <sup>3</sup> (0.24 yd <sup>3</sup> )	0.15 m <sup>3</sup> (0.20 yd <sup>3</sup> )	5	670 mm (26.4")	740 mm (29.1")
	OPT	0.07 m <sup>3</sup> (0.09 yd <sup>3</sup> )	0.06 m <sup>3</sup> (0.08 yd <sup>3</sup> )	3	315 mm (12.4")	360 mm (14.2")

## 9. RECOMMENDED OILS

Use only oils listed below or equivalent.  
Do not mix different brand oil.

Service point	Kind of fluid	Capacity l (U.S. gal)	Ambient temperature °C ( °F)						
			-20 (-4)	-10 (14)	0 (32)	10 (50)	20 (68)	30 (86)	40 (104)
Engine oil pan	Engine oil	11.6 (3.1)	SAE 30						
			SAE 10W						
			SAE 10W-30						
			SAE 15W-40						
Swing drive	Grease	0.35 (0.09)	NLGI NO.1			NLGI NO.2			
	Gear oil	1.5 (0.4)	SAE 85W-140						
Final drive	Gear oil	1.2×2 (0.3×2)							
Hydraulic tank	Hydraulic oil	Tank: 70 (18.5) System: 120 (31.7)	ISO VG 32						
			ISO VG 46						
			ISO VG 68						
Fuel tank	Diesel fuel	120 (31.7)	ASTM D975 NO.1			ASTM D975 NO.2			
Fitting (Grease nipple)	Grease	As required	NLGI NO.1			NLGI NO.2			
Radiator (Reservoir tank)	Mixture of antifreeze and water 50 : 50	9.5 (2.5)	Ethylene glycol base permanent type						

**SAE** : Society of Automotive Engineers  
**API** : American Petroleum Institute  
**ISO** : International Organization for Standardization  
**NLGI** : National Lubricating Grease Institute  
**ASTM** : American Society of Testing and Material