

GROUP 6 TURNING JOINT

1. DISASSEMBLY AND ASSEMBLY

1) STRUCTURE

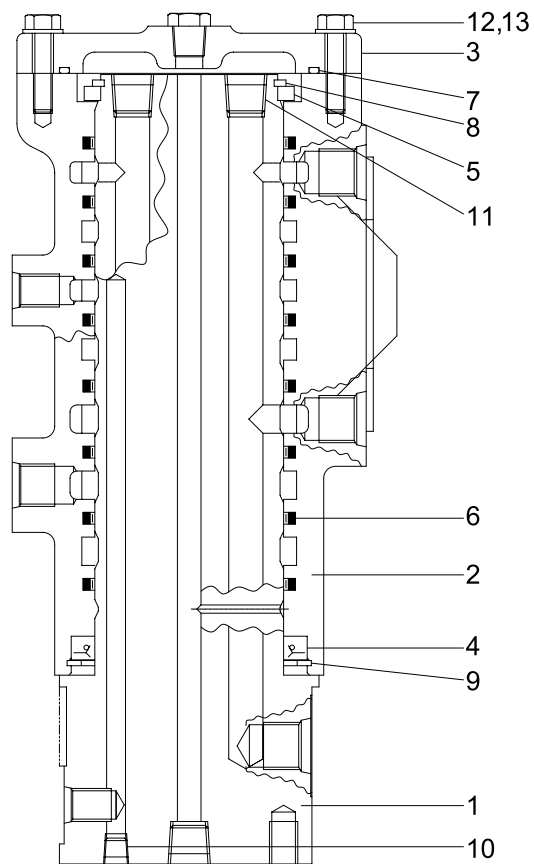

R55NM7TJ01

- | | | | | | |
|---|----------|---|---------------|----|---------------|
| 1 | Hub | 6 | Slipper seal | 10 | Plug |
| 2 | Shaft | 7 | O-ring | 11 | Plug |
| 3 | Cover | 8 | Retainer ring | 12 | Hexagon bolt |
| 4 | Oil seal | 9 | Retainer ring | 13 | Spring washer |
| 5 | Ring | | | | |

2) DISASSEMBLY

Before the disassembly, clean the turning joint.

- (1) Remove bolts(12), washer(13) and cover(3).

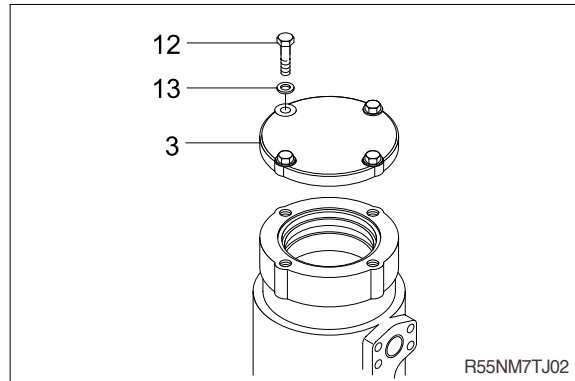

- (2) Remove O-ring(7).
- (3) Remove retainer ring(9) and spacer(4).

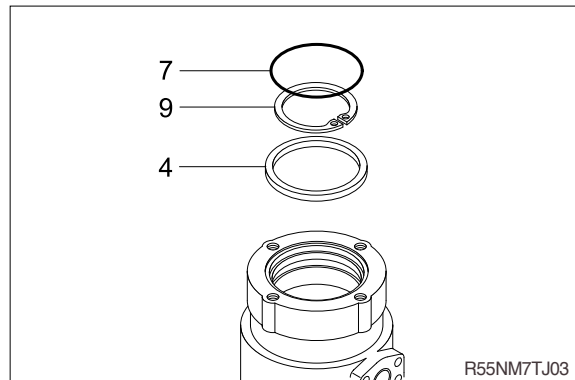

- (4) Place hub(1) on a V-block and by using a wood buffer at the shaft end, hit out shaft(2) to about 1/2 from the body with a hammer.

Take care not to damage the shaft(2) when remove hub(1) or rest it sideways.
Put a fitting mark on hub(1) and shaft(2).

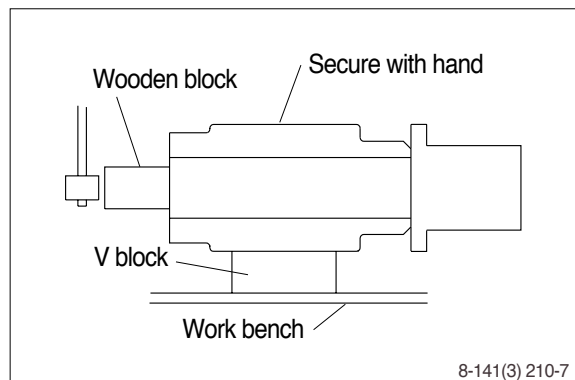

- (5) Remove eight slipper seals(6) and oil seal(4), retainer ring(9) from hub(1).

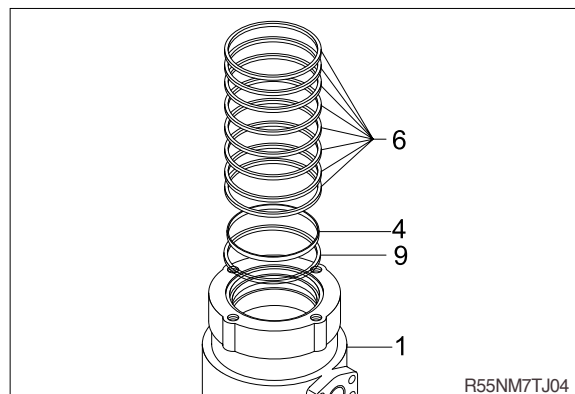

3) ASSEMBLY

Clean all parts.

As a general rule, replace oil seals and O-ring.

Coat the sliding surfaces of all parts with engine oil or grease before installing.

- (1) Fix eight slipper seal(6) and oil seal(4), retainer ring(9) to hub(1).

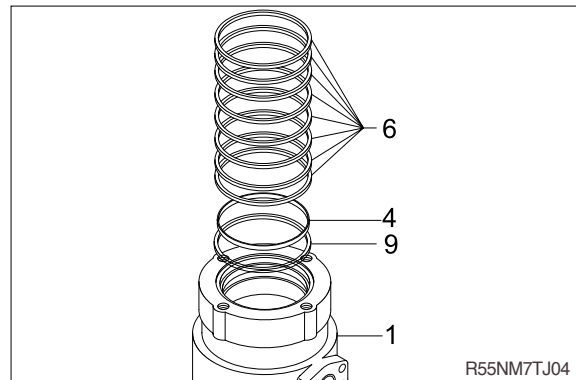

- (2) Set shaft(2) on block, tap hub(1) with a plastic hammer to install.

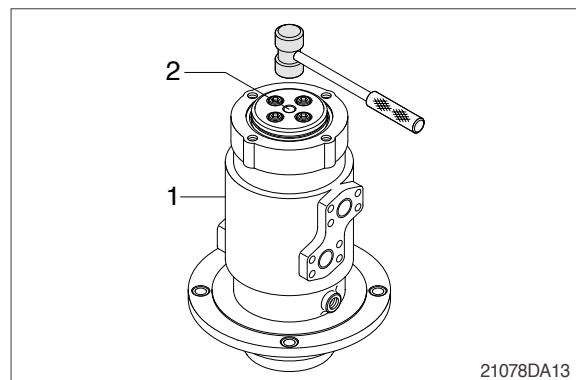

- (3) Fit spacer(4) and retainer ring(9) to shaft(2).

- (4) Fit O-ring(7) to hub(1).

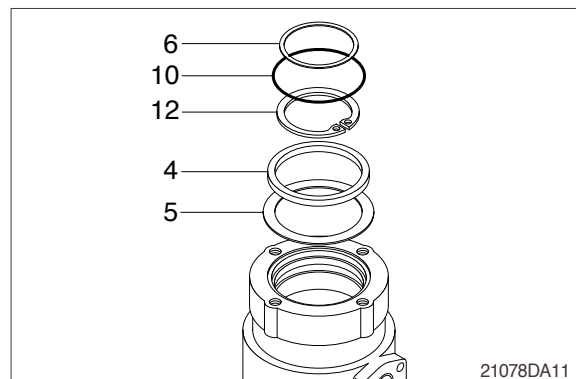

(5) Install cover(3) to body(1) and tighten bolts(12).

