

# GROUP 4 TRAVEL DEVICE

## 1. CONSTRUCTION

Travel device consists travel motor and gear box.

Travel motor includes brake valve, parking brake and high/low speed changeover mechanism.

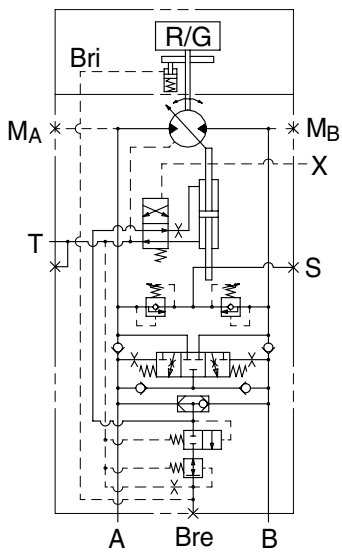
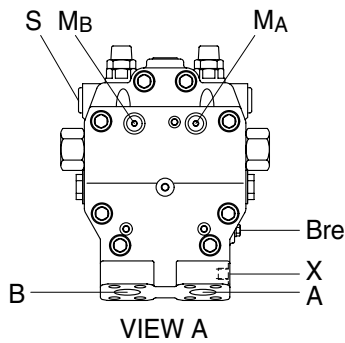
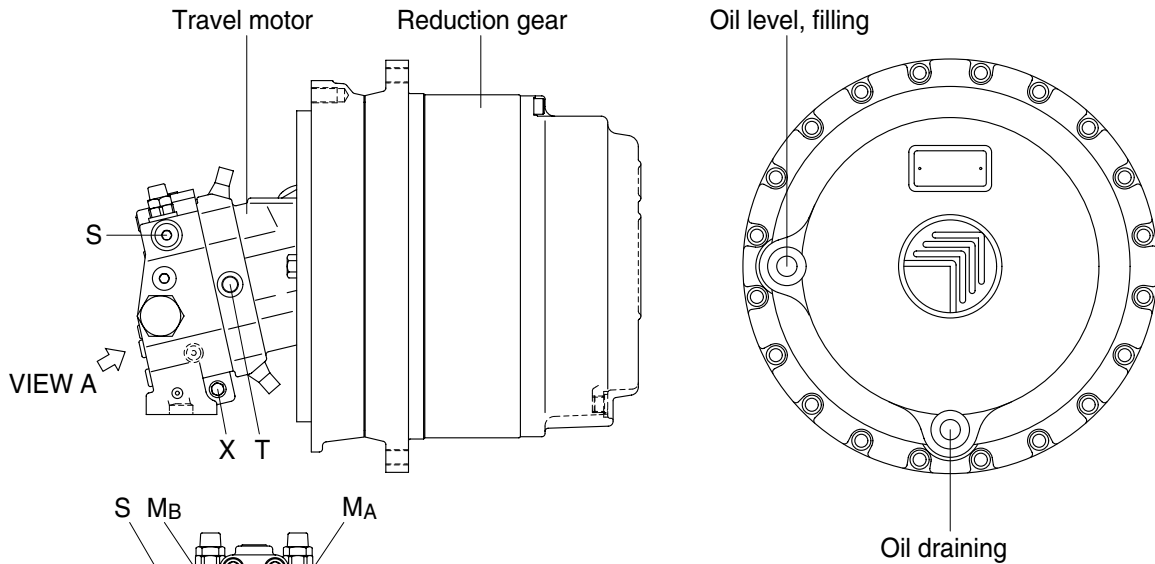

Hydraulic circuit

450A2TO01

Port	Port name	Port size
A	Main port	SAE 6000 psi 1 1/4"
B	Main port	SAE 6000 psi 1 1/4"
MA, MB	Gauge port	M14 × 1.5
T	Drain port	M26 × 1.5
X	2 speed control port	M14 × 1.5
Bre	Gauge port	M14 × 1.5
Bri	Brake release port	Internal

# 1) TRAVEL MOTOR (1/2)

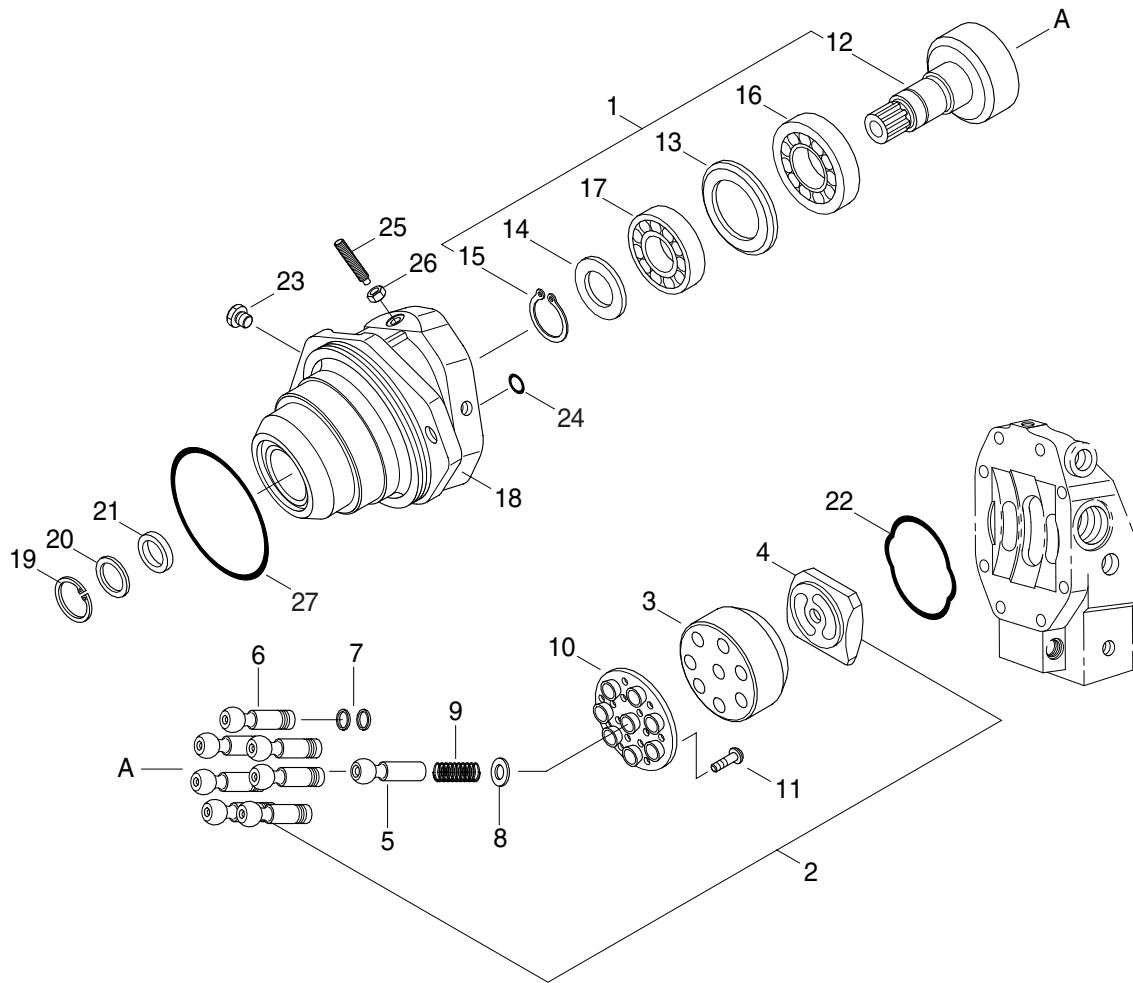

450A8T002

- |   |                    |    |                |    |                 |
|---|--------------------|----|----------------|----|-----------------|
| 1 | Rotary group       | 10 | Retainer plate | 19 | Retainer ring   |
| 2 | Hyd section rotary | 11 | Screw          | 20 | Shaft seal ring |
| 3 | Cylinder           | 12 | Drive shaft    | 21 | Back up plate   |
| 4 | Control lens       | 13 | Shim           | 22 | O-ring          |
| 5 | center pin         | 14 | Back up plate  | 23 | Locking screw   |
| 6 | Piston             | 15 | Retainer ring  | 24 | O-ring          |
| 7 | Steel ring         | 16 | Roller bearing | 25 | Threaded pin    |
| 8 | Adjustment shim    | 17 | Roller bearing | 26 | Seal lock nut   |
| 9 | Pressure spring    | 18 | Housing        | 27 | O-ring          |

## TRAVEL MOTOR (2/2)

### · Control part

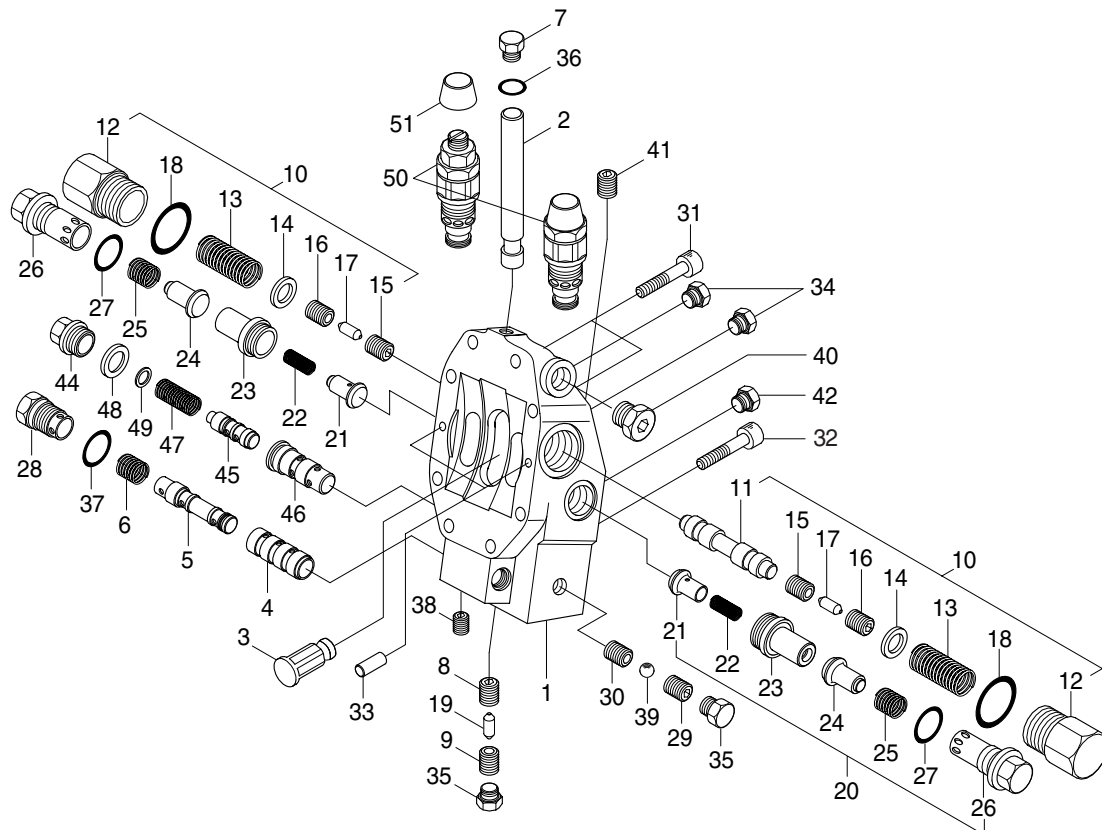

450A8T003

- |    |                   |    |                 |    |                        |
|----|-------------------|----|-----------------|----|------------------------|
| 1  | Port plate        | 18 | O-ring          | 35 | Locking screw          |
| 2  | Position piston   | 19 | Throttle pin    | 36 | O-ring                 |
| 3  | Position turnnion | 20 | Valve           | 37 | O-ring                 |
| 4  | Control bushing   | 21 | Poppet valve    | 38 | Brake off pin          |
| 5  | Control piston    | 22 | Pressure spring | 39 | Ball                   |
| 6  | Pressure spring   | 23 | Seat poppet     | 40 | Locking screw          |
| 7  | Locking screw     | 24 | Poppet valve    | 41 | Brake off pin          |
| 8  | Throttle screw    | 25 | Pressure spring | 42 | Locking screw          |
| 9  | Throttle screw    | 26 | Locking screw   | 43 | Pressure control valve |
| 10 | Brake valve       | 27 | O-ring          | 44 | Locking screw          |
| 11 | Brake piston      | 28 | Locking screw   | 45 | Control piston         |
| 12 | Locking screw     | 29 | Valve screw     | 46 | Control bushing        |
| 13 | Pressure spring   | 30 | Bushing         | 47 | Pressure spring        |
| 14 | Washer            | 31 | Socket screw    | 48 | O-ring                 |
| 15 | Throttle screw    | 32 | Socket screw    | 49 | Shim                   |
| 16 | Throttle screw    | 33 | Cylinder pin    | 50 | Relief pressure valve  |
| 17 | Throttle pin      | 34 | Locking screw   | 51 | Cap                    |

## 2) REDUCTION GEAR

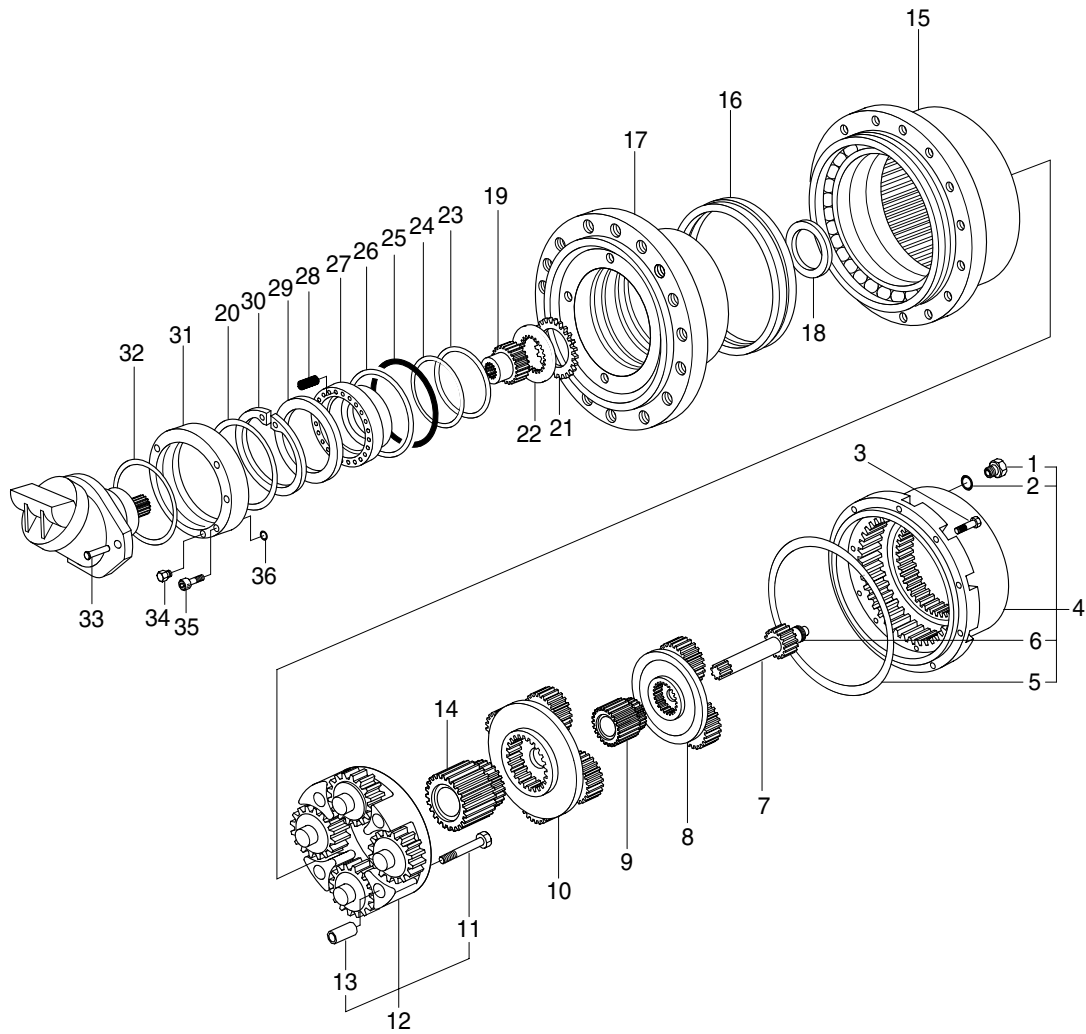

450A8TR01

1	Washer	13	Bushing	25	O-ring
2	Breather plug	14	Sun gear	26	Spiral ring
3	Screw	15	Housing	27	Piston
4	Cover set	16	Lifetime seal	28	Spring
5	O-ring	17	Hub	29	Spacer
6	Pad	18	Spacer	30	Circlip
7	Sun gear	19	Brake shaft	31	Flange
8	Reduction assy(1st)	20	O-ring	32	O-ring
9	Sun gear	21	Brake disc	33	Screw
10	Reduction assy(2nd)	22	Steel ring	34	Plug
11	Screw	23	Back up ring	35	Screw
12	Reduction assy(3rd)	24	O-ring	36	O-ring

## 2. FUNCTION

### 1) HYDRAULIC MOTOR (plug-in motor with intergrated counter balance valve)

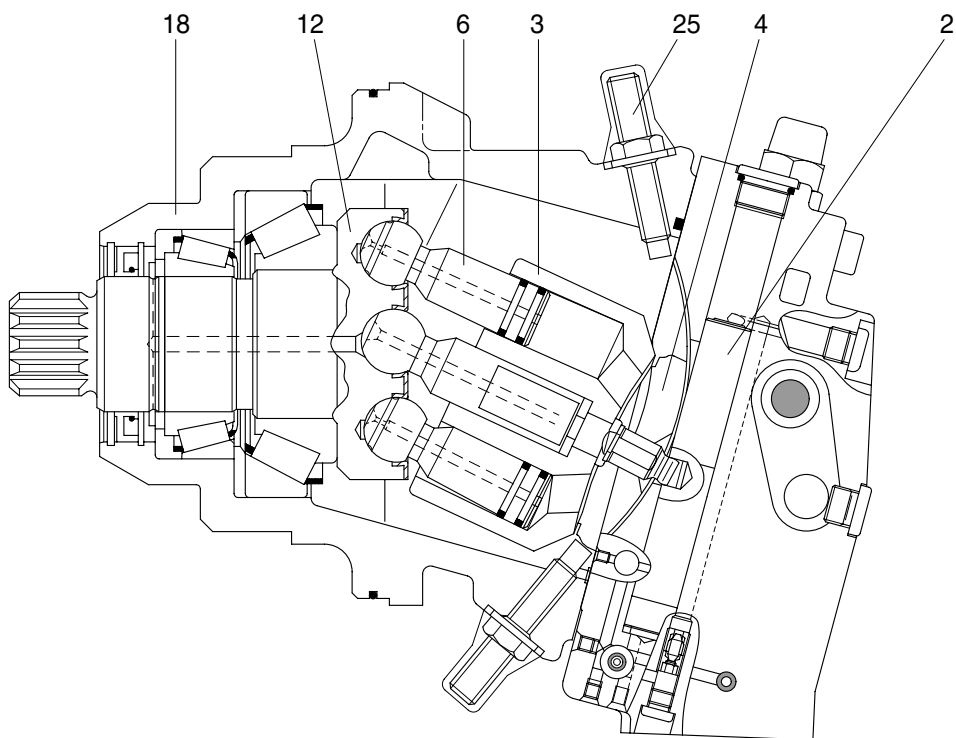

450A2TO02

The variable displacement motor has a rotary group in bent axis design.

The torque is generated directly at the drive shaft (12).

The cylinder barrel (3) is driven by a tapered piston (6) arrangement.

The change of displacement is generated by the control lens (4) via positioning piston (2). The control lens (4) slides on a circular shaped surface.

In case of constant pump flow volume and high pressure

- the output speed is increased at smaller swivel angle, the torque is reduced
- the torque rises at swivel angle increase, the output speed is decreased.

The max. swivel angle is 25°, the min. swivel angle is 5°.

The variable displacement motor with integrated counterbalance valve is designed to be operated in open loop.

The min. displacement is limited by a threaded pin (25) in the housing (18). Min. displacement is set according to requirement. Stepless adjustment to various higher values is possible.

※ Reduction to smaller displacement may result in overspeeding the motor.

## 2) PORT PLATE

With hydraulic two-speed control, integrated counterbalance valve and secondary pressure relief valves, gauge and boosting ports, control pressure ports, brake release pressure ports and service ports.

## 3) HYDRAULIC TWO-SPEED CONTROL

Operated by control pressure at port X a 4/2 directional valve guides high pressure to the positioning piston to switch the motor from min. to max. displacement and vice versa.

At control pressure 0 bar at port X the motor is at max. displacement.

At control pressure > 10bar at port X the motor is at min. displacement.

Intermediate positions are not possible.

The necessary positioning energy is taken from the respective high pressure side via shuttle valve. For this an operating pressure of at least 15bar is necessary.

Swivelling results in a change of the displacement.

Swivel time is controlled by an orifice.

## 4) COUNTERBALANCE VALVE (for traveling)

Integrated into the port plate including a brake release valve.

In case of downhill traveling or deceleration of the vehicle a counterbalance valve avoids overspeeding and cavitation of hydraulic motors.

## 5) FUNCTION AS TO CIRCUIT DIAGRAM

Check valves in the inlet line A and B for by-passing of the counterbalance valve.

At traveling forward the return oil flow is controlled by a counterbalance spool. At drop in inlet pressure the counterbalance spool throttles the return oil flow. The motor is locked. The oil flow behind the spool is led to the low pressure side via an additional check valve. Same function for traveling forward and backward. For limitation of the max. pressure during braking operation two cross-over relief valves are installed. Cavitation can be prevented via cross-over relief valves functioning as a check valve. A brake release valve pressurized by one of the inlet pressure sides via shuttle valve builds up a maximum of 30-50bar to release parking brake. The brake release valve delays the engagement of parking brake after travelling.

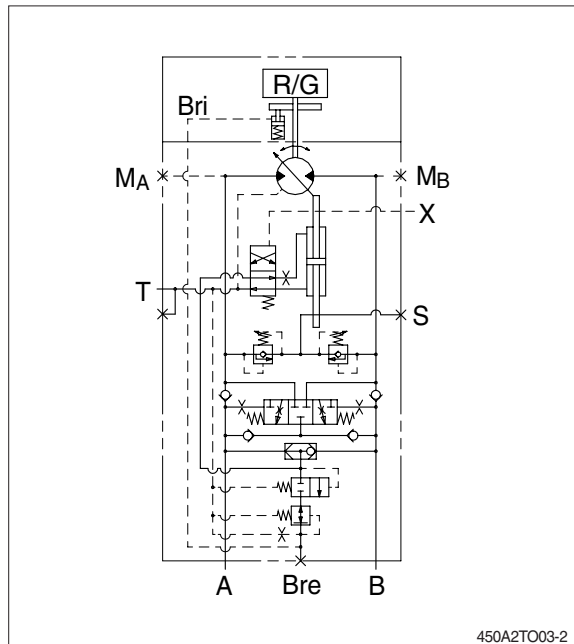
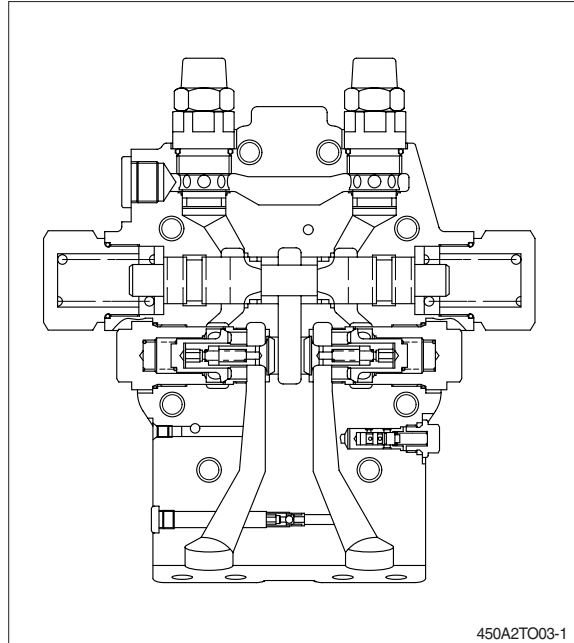

## 6) REDUCTION GEAR

The reduction gear is composed of a three-stage planetary gear mechanism shown in the following figure. Since the sun gear is designed to have a floating mechanism, errors of the gears and carrier pin hole pitches will not affect the gears' lives heavily.

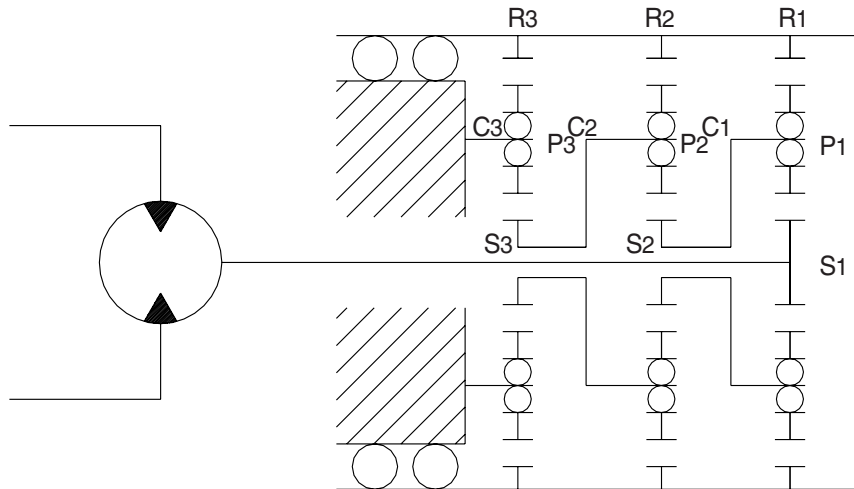

R290TM08(1)

The input rotation of the hydraulic motor is transmitted to No. 1 sun gear (S1) and this drives No. 1 planetary gears (P1). This No. 1 planetary gears (P1) drive No.1 ring gear (R1) with the same force as the meshing tangential force with No. 1 sun gear (S1), and also No. 1 carrier (C1) with the same force as the meshing reaction force. In other words, No. 1 planetary gears (P1) revolve rotating. This rotation of No. 1 carrier (C1) becomes the output of the 1st stage, and is transmitted directly to No. 2 sun gear (S2).

(No. 1 carrier is spline-coupled with No. 2 sun gear.) Similarly the revolution of No. 2 planetary gear (P2) are transmitted via No.2 carrier (C2) to No. 3 sun gear (S3). Since No. 3 carrier (C3) supporting No. 3 planetary gears (P3) are fixed, No. 3 planetary gears (P3) do not revolve, but rotates to drive No. 3 ring gears (R3).

Therefore, the rotating case is driven by the overall driving torque of numbers.

1,2 and 3 ring gears. This reduction ratio is expressed as shown below:

$$i = \frac{(Z_{S1} + Z_{R1}) (Z_{S2} + Z_{R2}) (Z_{S3} + Z_{R3})}{Z_{S1} \cdot Z_{S2} \cdot Z_{S3}} - 1$$

Where Z : Number of teeth of each gear

The direction of rotation is reverse to that of the input shaft.