

# GROUP 2 MAIN CONTROL VALVE

## 1. STRUCTURE

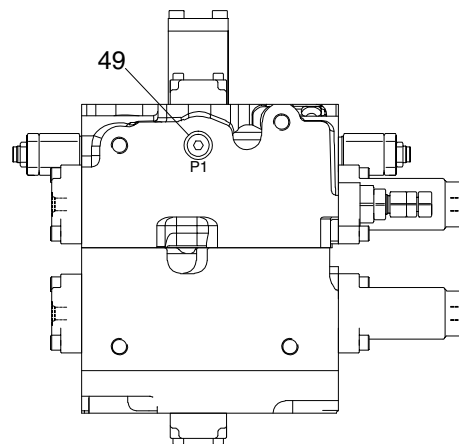
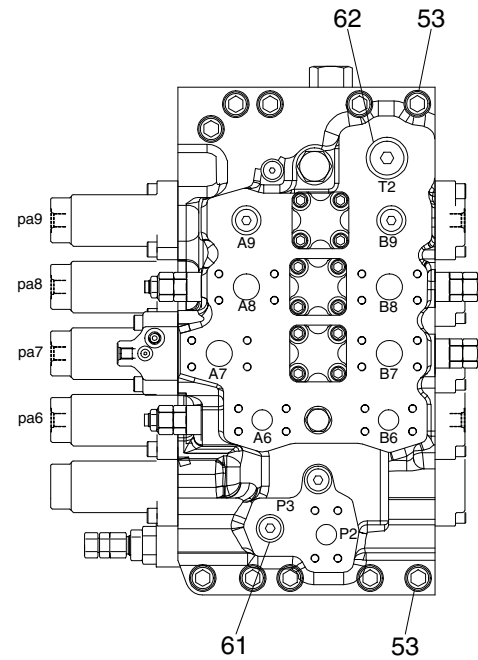
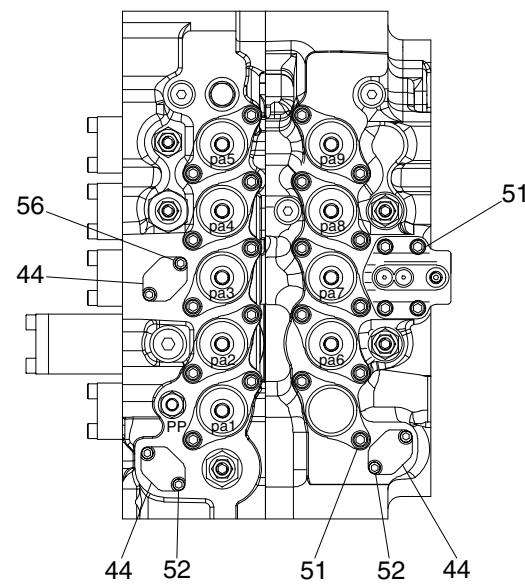
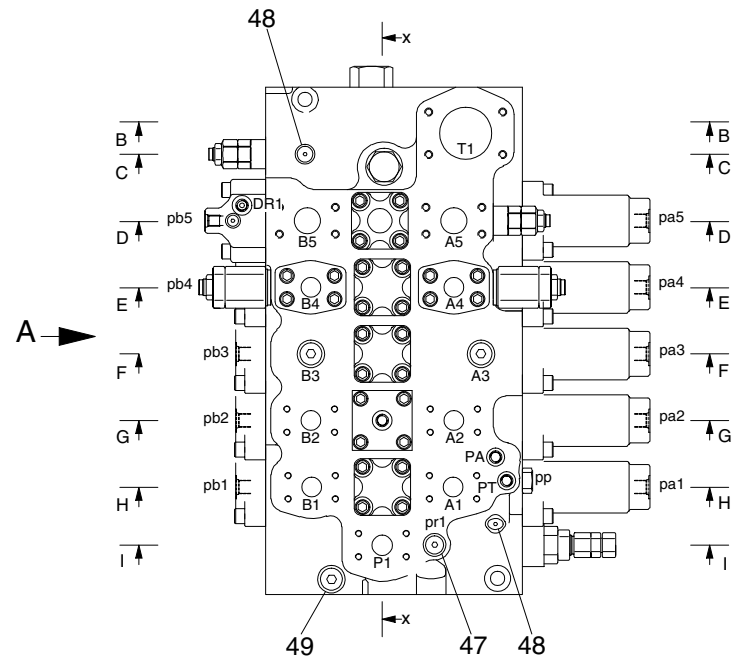
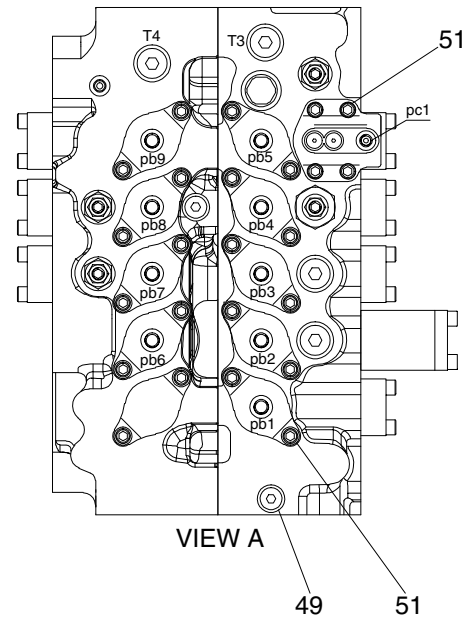
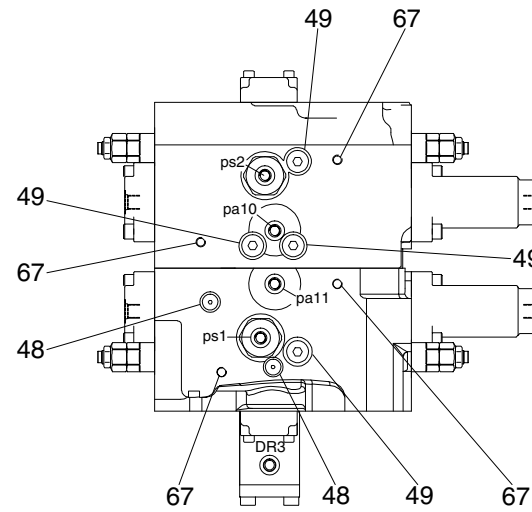

Mark	Port size	Thread depth (mm)
DR1, DR2, DR3, pr1, ps1, ps2, pc1, pc2, pc6, pa10, pa11, PA, PT, PP, PH	PF 1/4	12
pa1~pa9, pb1~pb9	PF 3/8	14
A3, A9, B3, B9, P1, P3	PF 1/2	16
T3, T4	PF 3/4	17
T2	PF 1	21

- |     |                     |     |                           |
|-----|---------------------|-----|---------------------------|
| 1   | Valve housing (P1)  | 35  | H/D valve assy            |
| 2   | Valve housing (P2)  | 36  | M/R valve assy            |
| 3   | Arm 2 spool assy    | 37A | O/R valve assy            |
| 4   | Bucket spool assy   | 37B | O/R valve assy            |
| 5   | Boom 1 spool assy   | 38  | Negacon valve assy        |
| 6   | Travel spool assy   | 39  | Plug assy                 |
| 7   | TS spool assy       | 40  | Poppet                    |
| 8   | Arm 1 spool assy    | 41  | Spring                    |
| 9   | Service spool assy  | 42  | Plug                      |
| 10  | Boom 2 spool assy   | 43  | O-ring                    |
| 11  | Swing spool assy    | 44  | Flange                    |
| 12A | Spool cap-A         | 45  | O-ring                    |
| 12B | Spool cap-B         | 46  | Plug assy                 |
| 13A | Spool flange-A      | 47  | Plug assy                 |
| 13B | Spool flange-B      | 48  | Plug assy                 |
| 14  | O-ring              | 49  | Plug assy                 |
| 15  | Popet               | 50  | Plug assy                 |
| 16  | Spring              | 51  | Socket head bolt          |
| 17  | Spacer              | 52  | Socket head bolt          |
| 18  | O-ring              | 53  | Socket head bolt          |
| 19  | Back up ring        | 54  | Name plate                |
| 20  | Spool assy          | 55  | Screw                     |
| 21  | Spring seat         | 56  | Socket head bolt          |
| 22  | Spool assy          | 57  | Poppet                    |
| 23  | Spring              | 58A | Service relief valve assy |
| 24  | O-ring              | 58B | Service relief valve assy |
| 25  | Plug                | 59  | O-ring                    |
| 26  | Poppet              | 60  | O-ring                    |
| 27  | Spring              | 61  | O-ring                    |
| 28  | Poppet              | 62  | Plug                      |
| 29  | Poppet              | 63  | Plug                      |
| 30  | Poppet              | 64  | Flange                    |
| 31  | Spring              | 65  | Socket head bolt          |
| 32  | Flange              | 66  | O-ring                    |
| 33  | O-ring              | 67  | Socket head bolt          |
| 34  | Swing priority assy | 68  | Socket head bolt          |



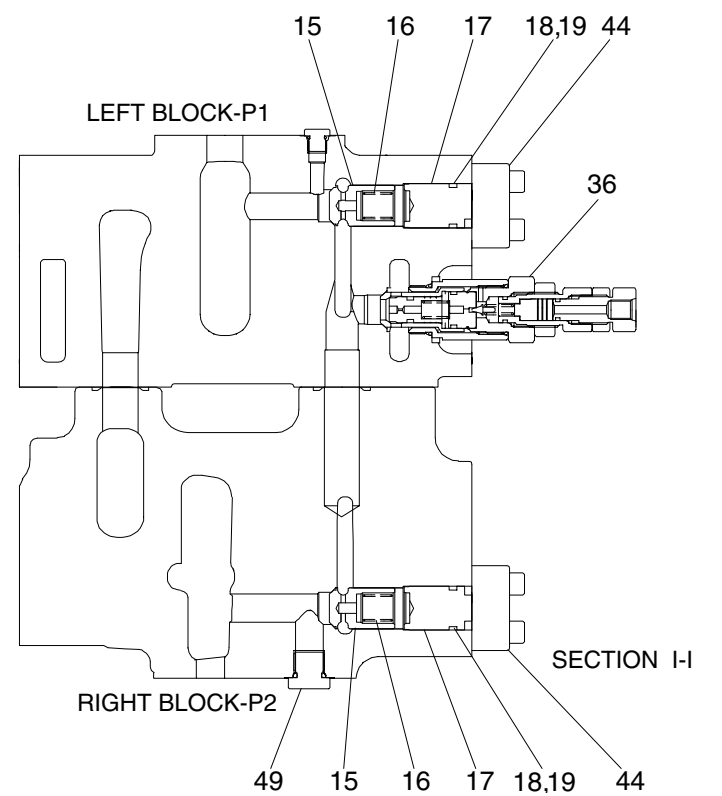
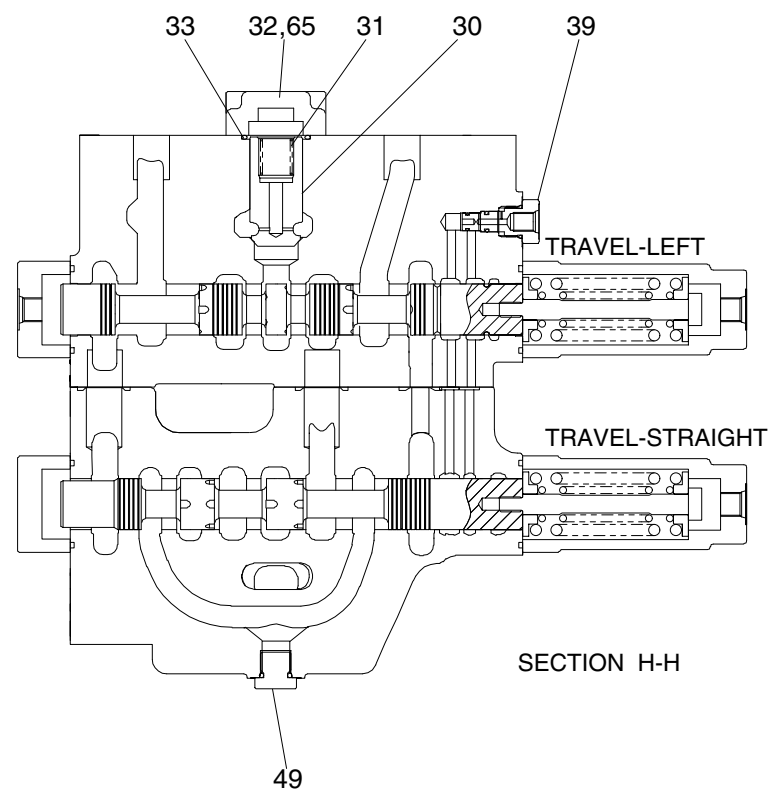
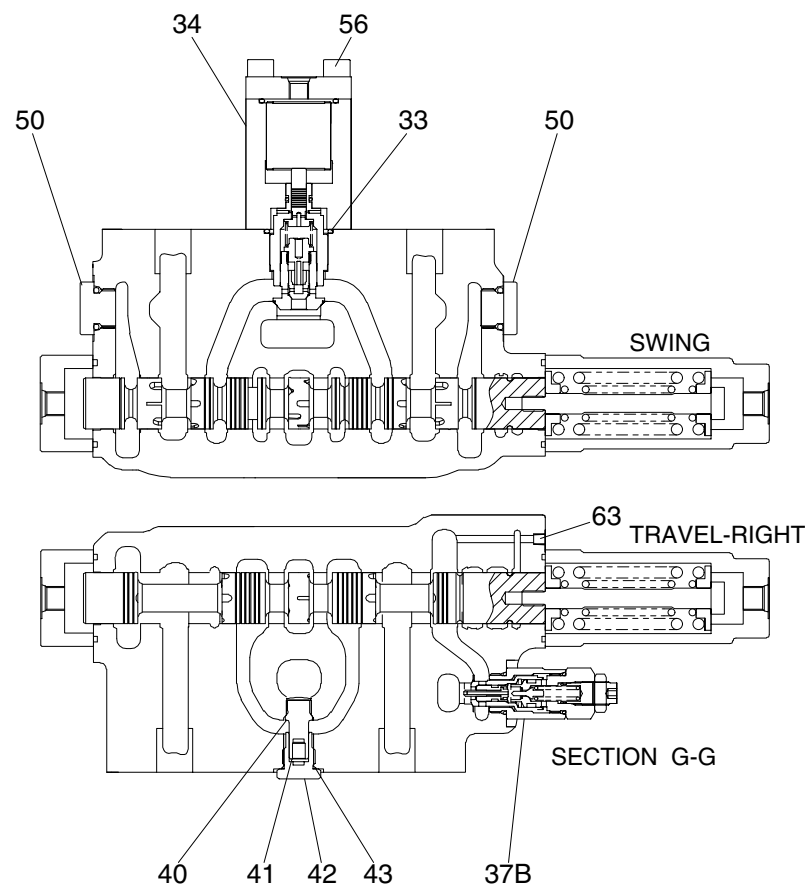
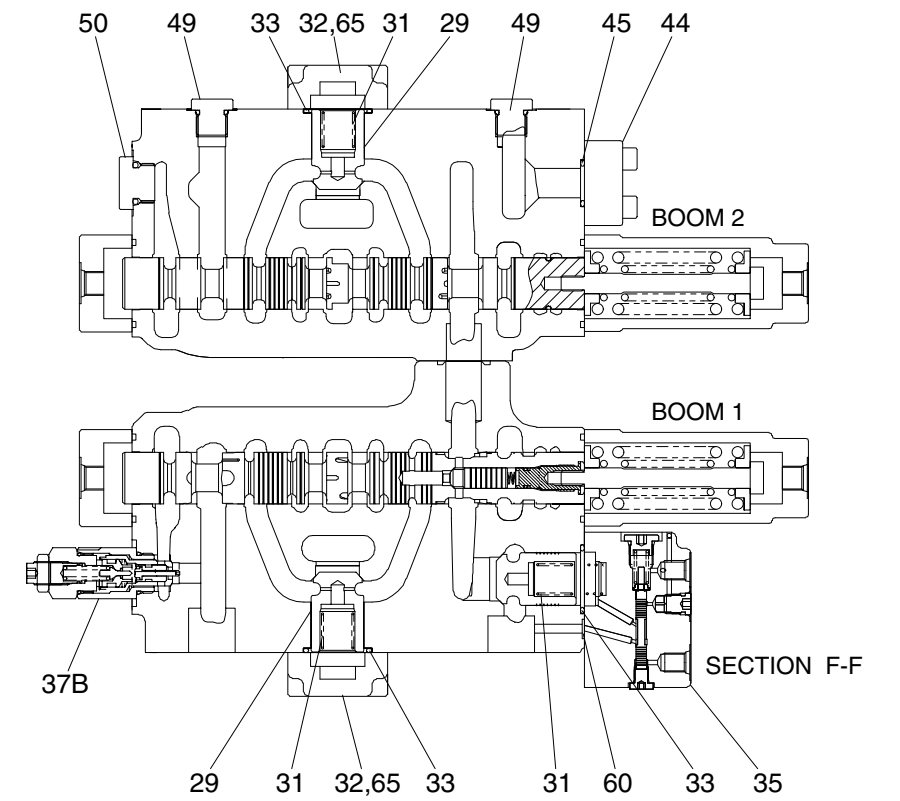
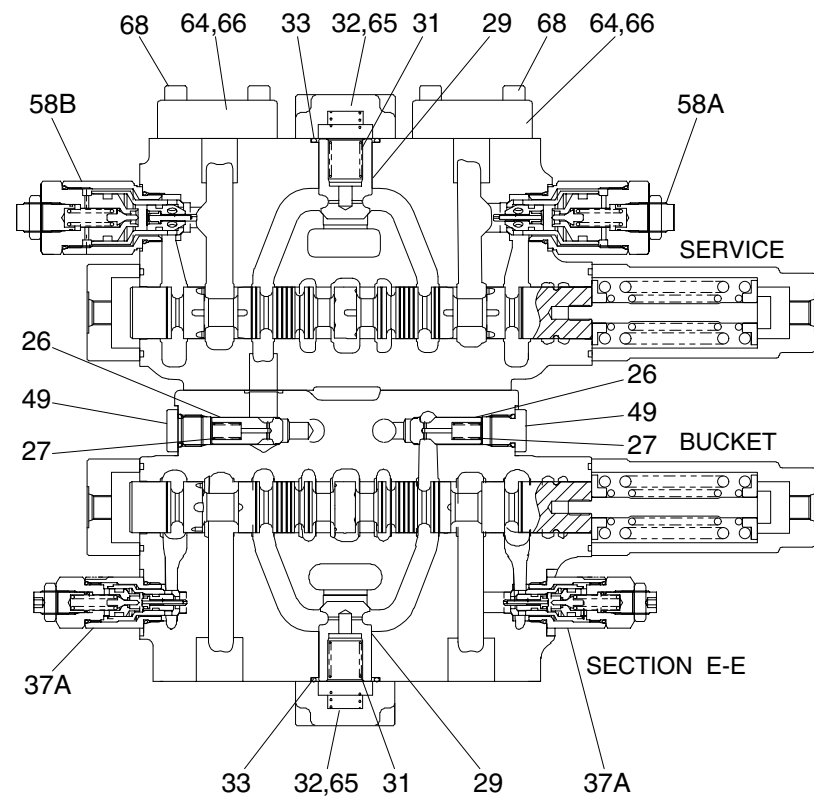
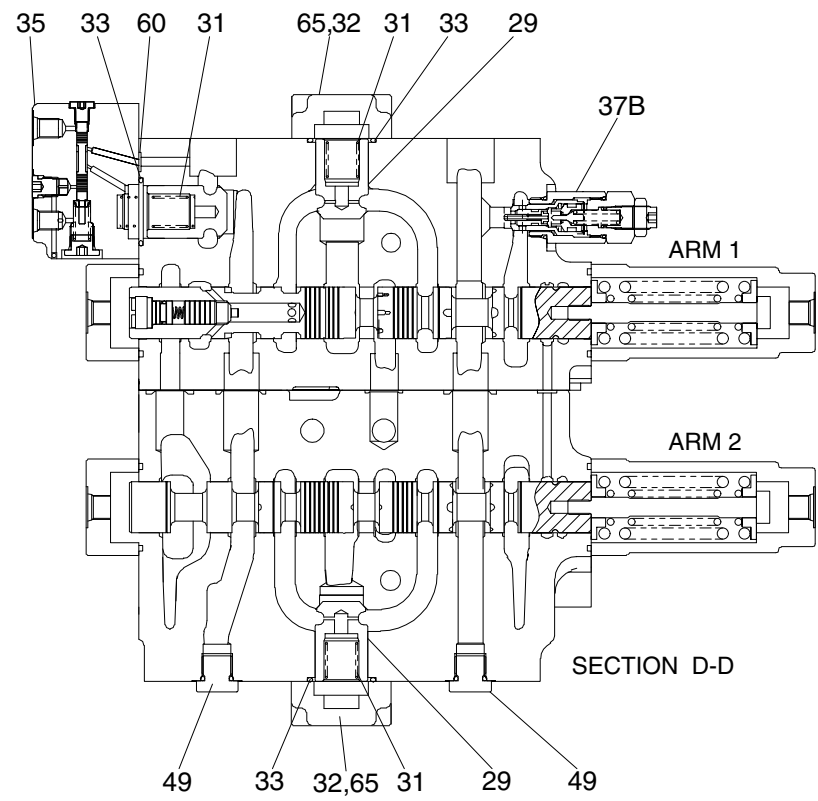

## 2. HYDRAULIC CIRCUIT

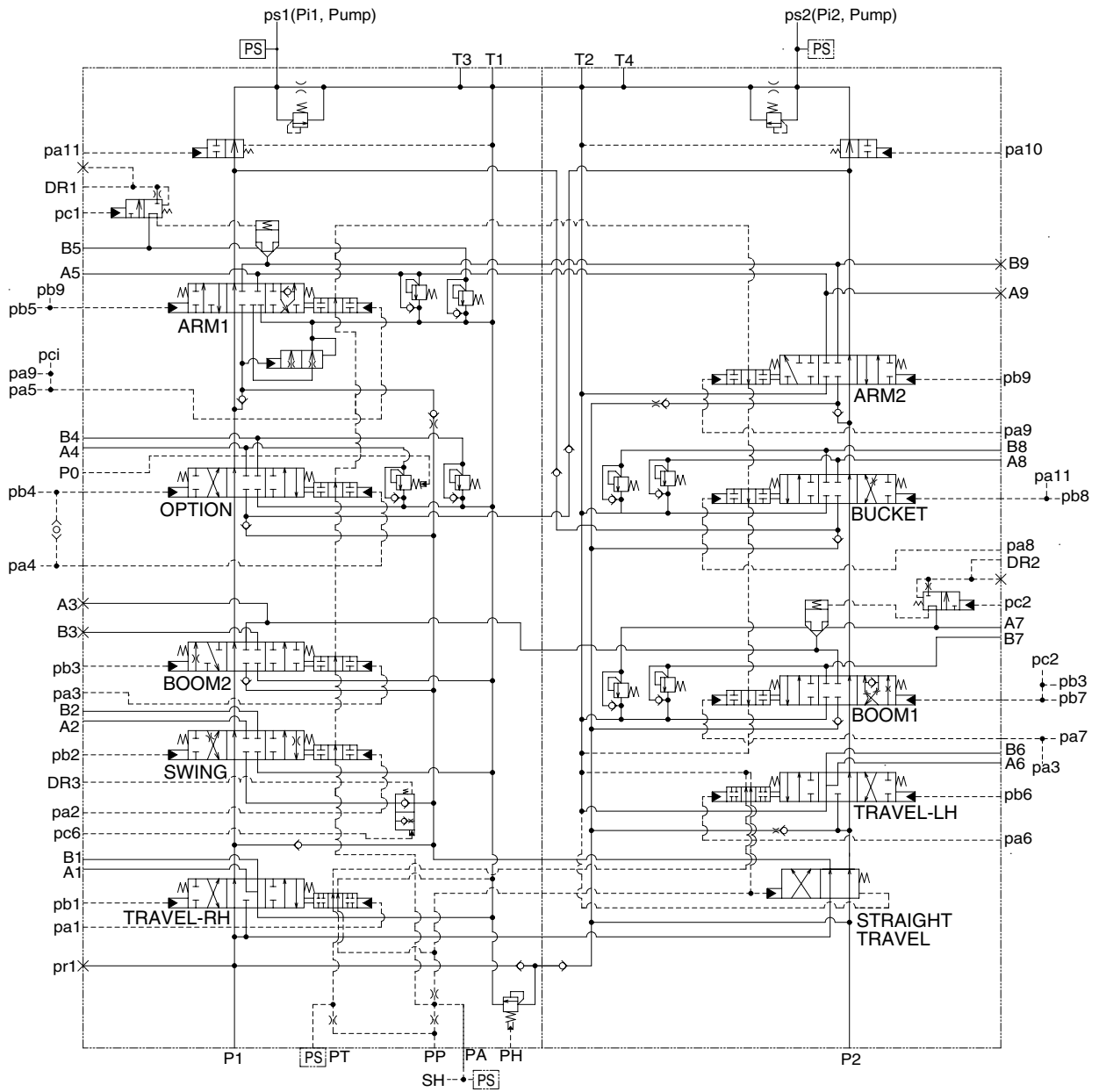

48092MC03A

### 3. OPERATION

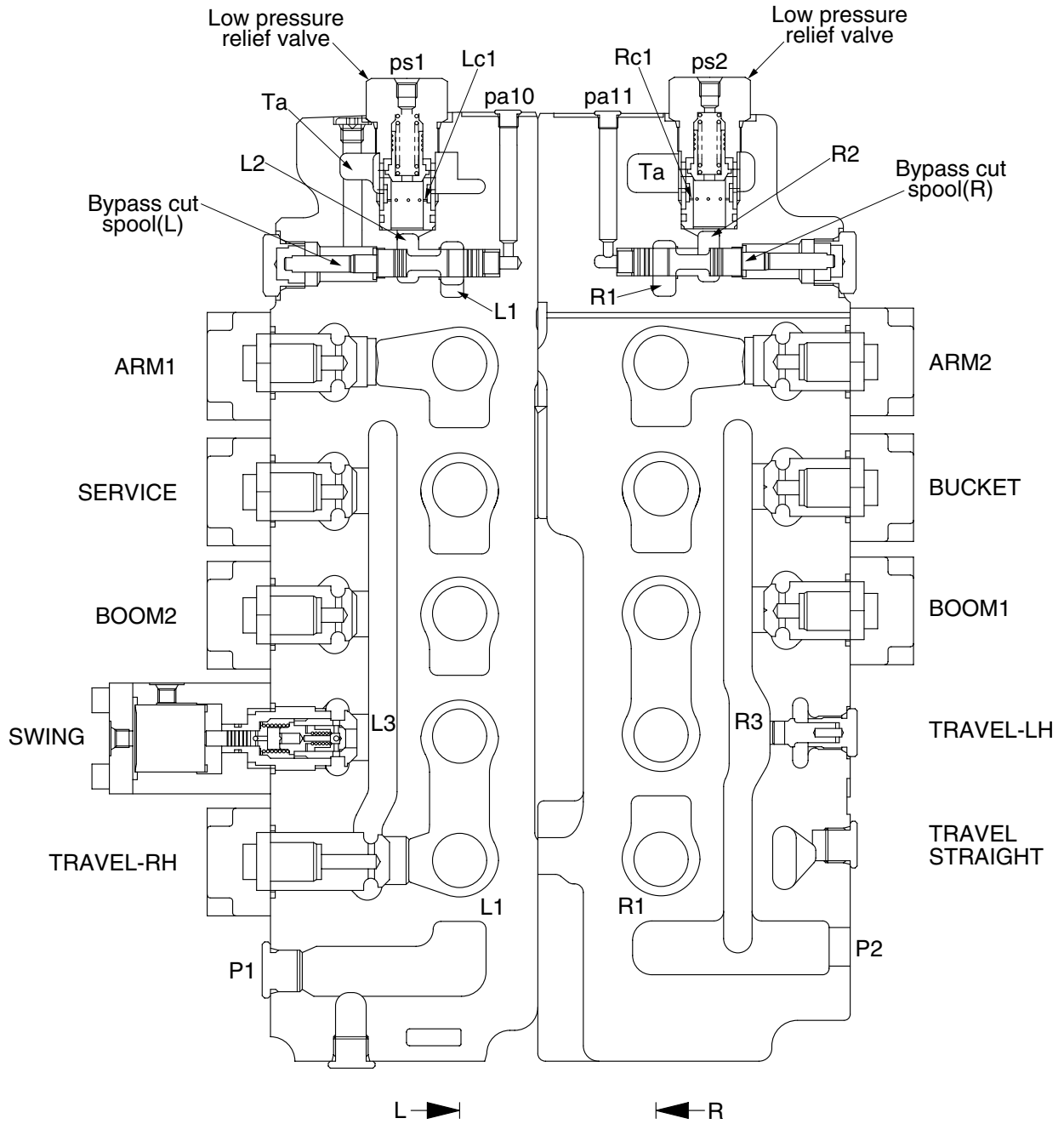

48092MC05A

## 1) ALL SPOOL NEUTRAL

### (1) Neutral passage

- ① Oil from pump P1 goes through neutral passage (L1) to the orifice (Lc1) of the low pressure relief valve and then oil returns to port T1 and T3 via tank passage (Ta).
- ② Oil from pump P2 goes through neutral passage (R1) to the orifice (Rc1) of the low pressure relief valve and then oil returns to port T1 and T3 via tank passage (Ta).
- ③ The pressure of upper chamber (L2), (R2) for the low pressure relief valve flow into pump through port ps1, ps2 and then controls the discharge of pump P1, P2.
- ④ When a large amount of oil flows the neutral passage, the low pressure relief valves is operated. As a result, the shock pressure of port ps1, ps2 is prevented.

### (2) Signal passage

- ① Oil from port PP flows into port PT via orifice (Lc3). At the same time, after passing through passage (⑤) via land (Lc4), oil returns to the tank passage (Ta) via land (Rc3).
- ② Meanwhile, some of oil from port PP flows into port PA via orifice (Lc5) and return to the tank passage (Ta) from boom 1 spool land (Rc4) via passage (L4, ⑧, R4).
- ③ Oil via orifice (Lc6) flows into the tank passage (Ta) from land (Lc7) and return to the tank passage (Ta) via travel spool land (Rc5) through the passage ④.

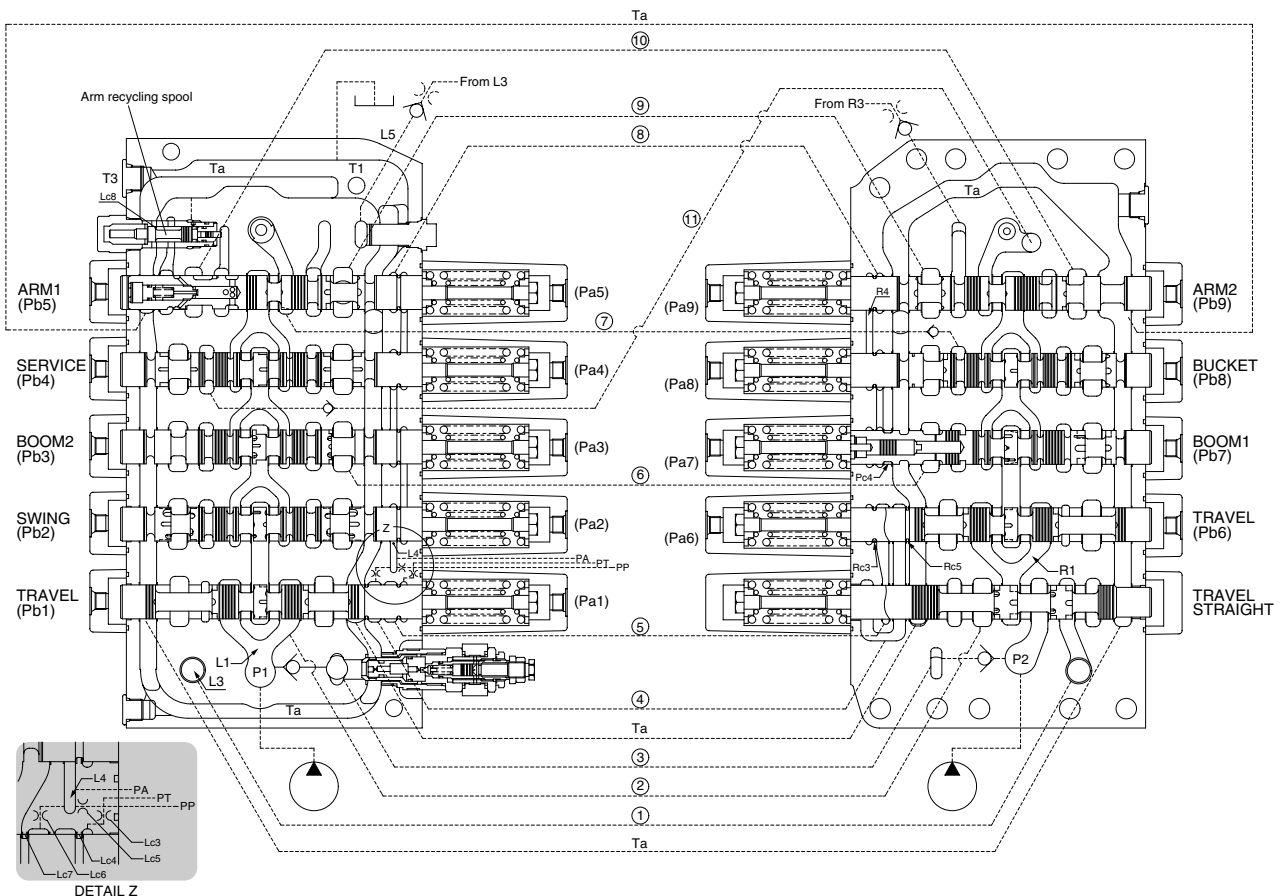

48092MC06

## 2) SINGLE OPERATION

### (1) Travel spool

When the RH travel spool is pushed to right by the pilot pressure of port Pb1 the oil discharged from P1 port flows from the neutral passage (L1) to B1 port.

The oil from port A1 return to the tank via the tank passage (Ta).

When the LH travel spool is pushed to right by the pilot pressure of port Pb6 the oil discharged from P2 port flows from the neutral passage (R1) to B6 port through the passage S6-1.

At this time, the parallel passage (R3) and passage (S6-1) are to be maintained as same pressure as poppet (S6-2) is closed. The oil from A6 returns to the tank via the tank passage (Ta).

When the travel spool is pushed to the right by the pilot pressure, the land (Lc4, Rc3) is closed and the tank passage of the oil discharged from port PP is closed, and then the pressure of PT port is increased.

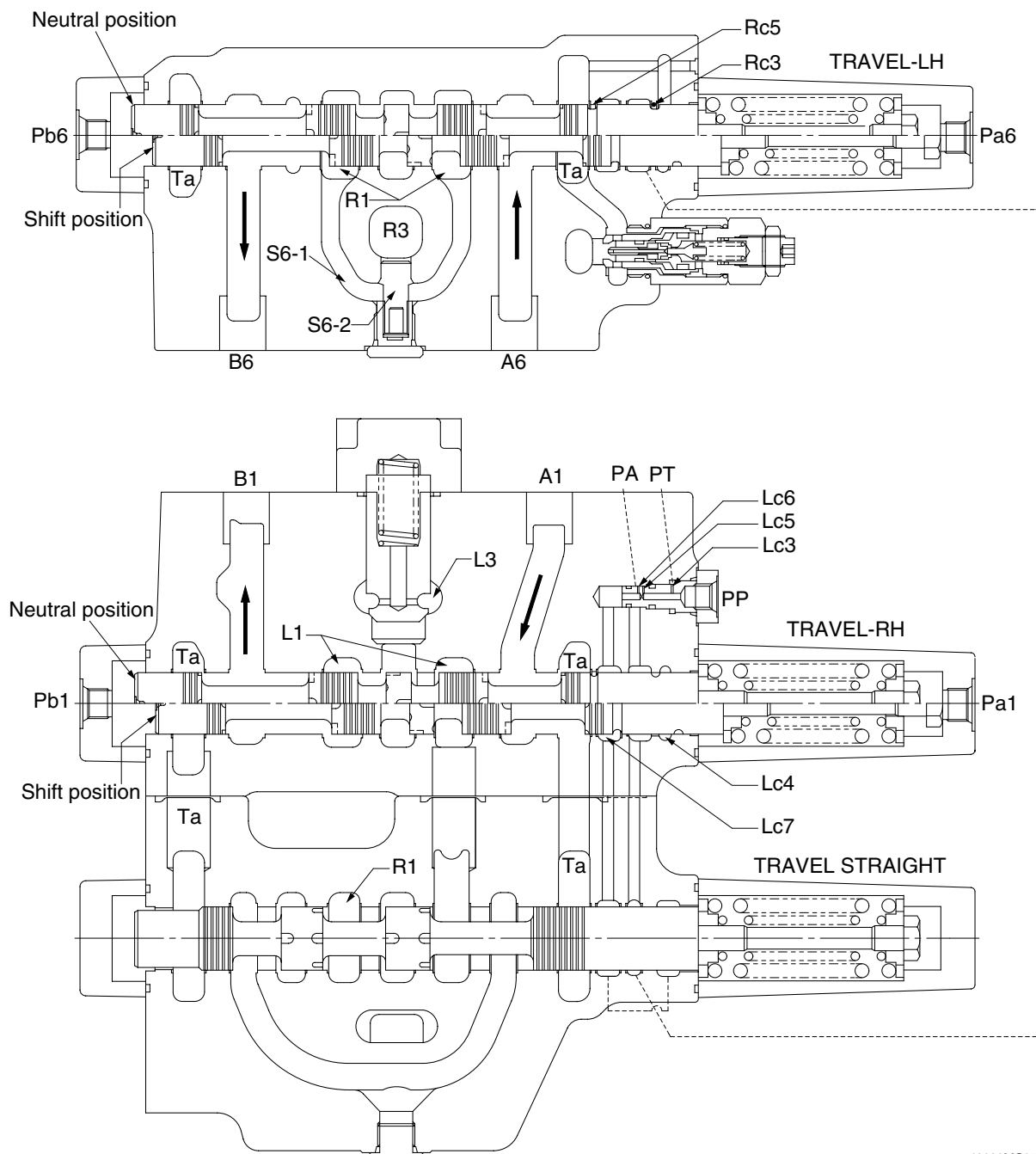

48092MC07

## (2) Swing spool

When the swing spool is pushed to the right by the pilot pressure of port Pb2, the neutral passage (L1) is closed, the oil discharged from pump P1 pushes up the load check valve (S2-1), passage (S2-2) via parallel passage (L3) and then flows into port B2.

The oil from port A2 return to the tank via the tank passage (Ta).

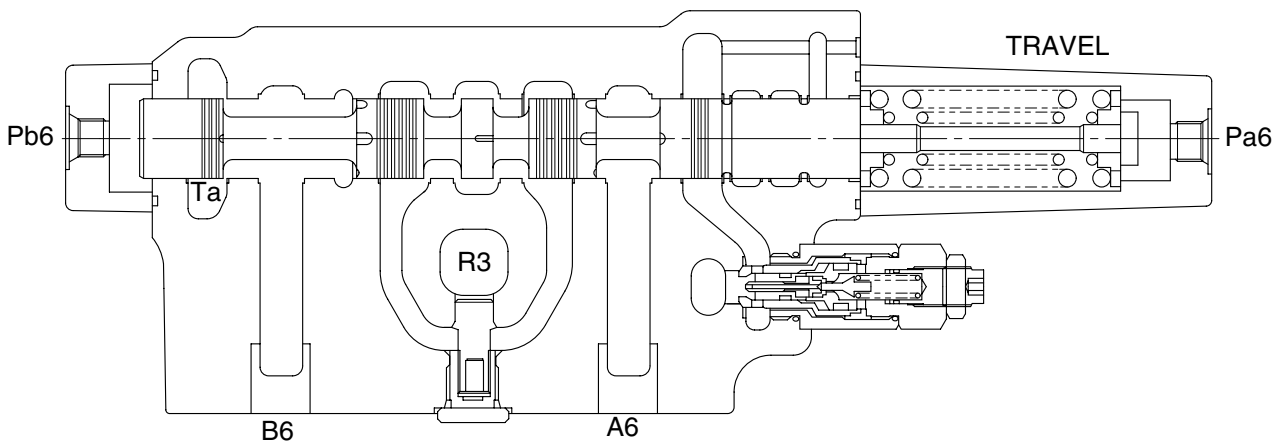
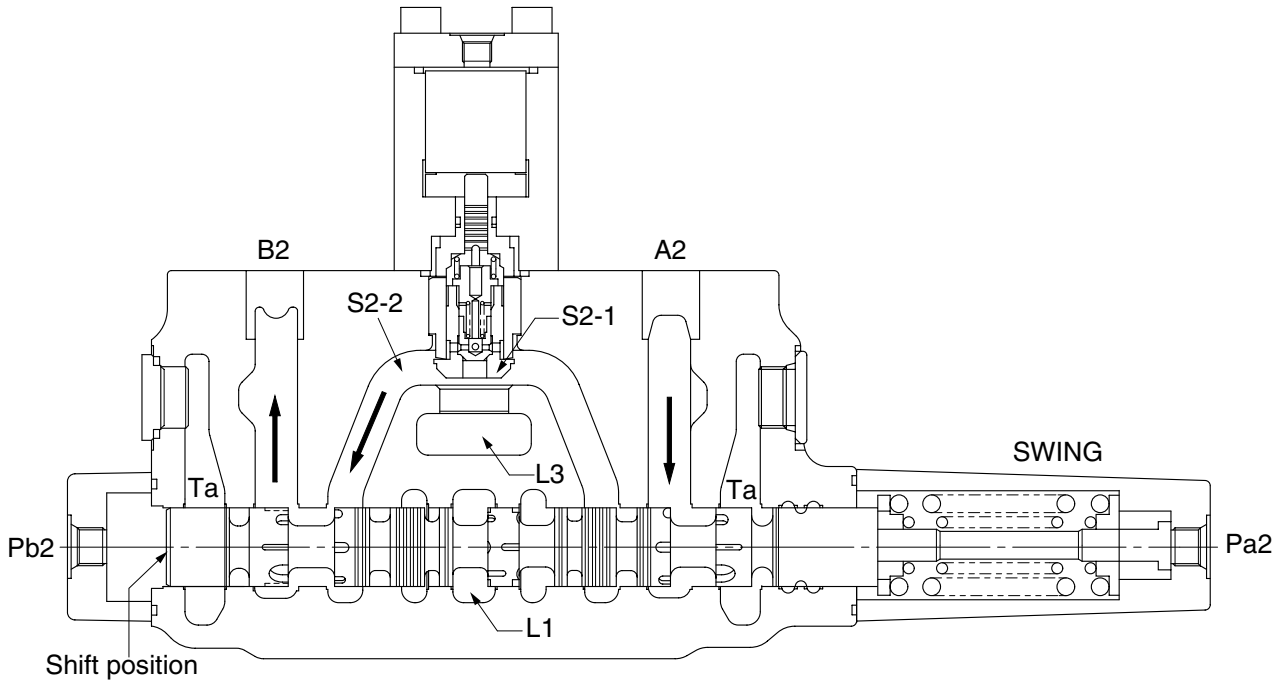

48092MC08

### 3) BOOM SPOOL

#### (1) Neutral

This valve is providing the anti-drift valve on the cylinder bottom side of boom 1 section. In neutral, the poppet (AD1) is seated by the pressure of spring chamber (AD5) because the oil from the port A7 is connection with spring chamber (AD5) via passage (AD2), spool (AD3) and passage (AD4).

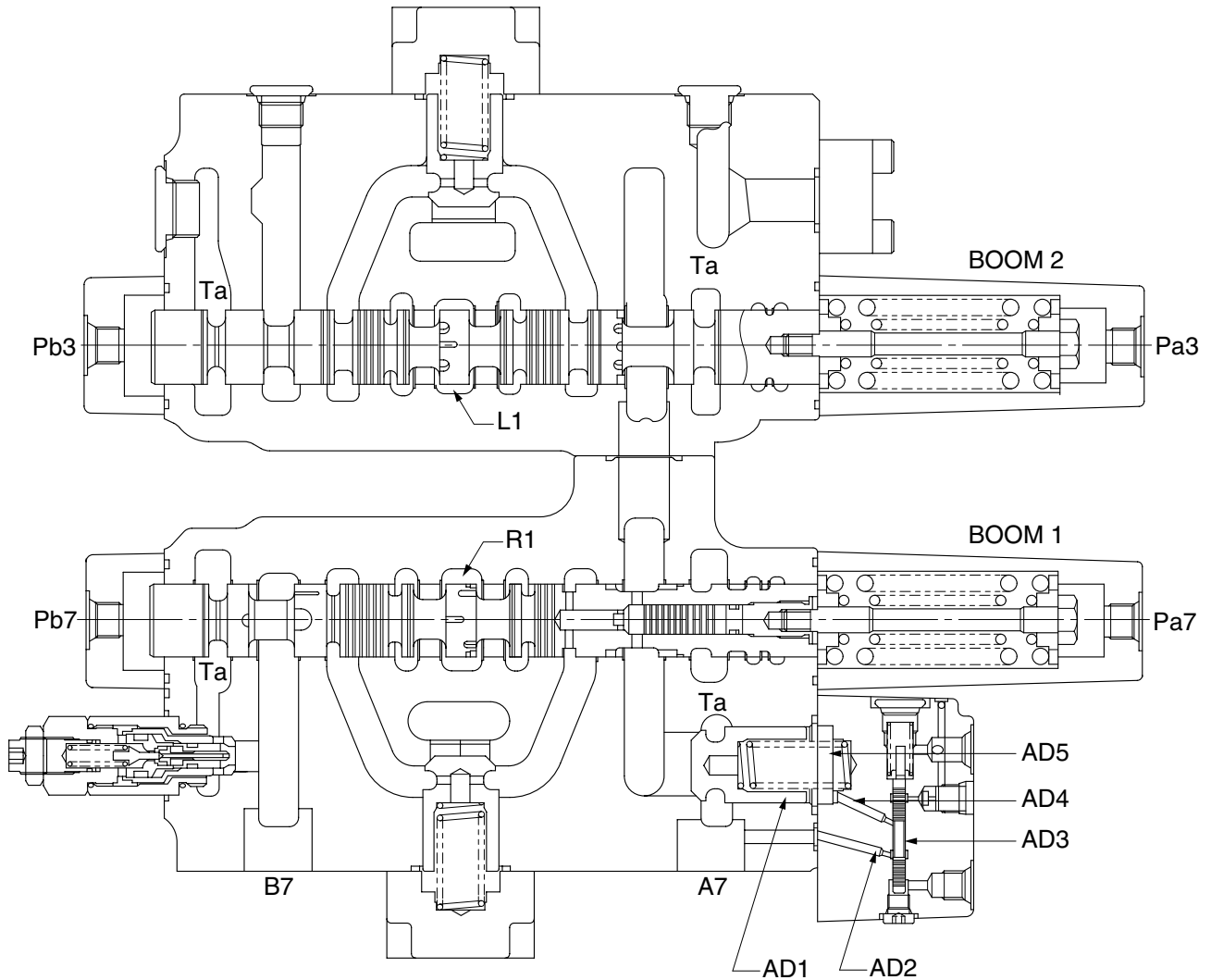

48092MC09

## (2) Boom up (flow summation)

When the boom 1 spool is pushed to the left by the pilot pressure of port Pa7, the neutral passage (R1) is closed, the oil discharged from pump P2 flows into the port A7 via parallel passage (R3), the load check valve (S7-1). At the same time, the boom 2 spool is pushed to the left by the pilot pressure of port Pa3, the neutral passage (L1) is closed, the oil discharged from pump P1 flows into the port A7 via parallel passage (L3), the load check valve (S3-1) and then joins to the passage (6).

The return oil from port B7 flows into the tank via the tank passage (Ta).

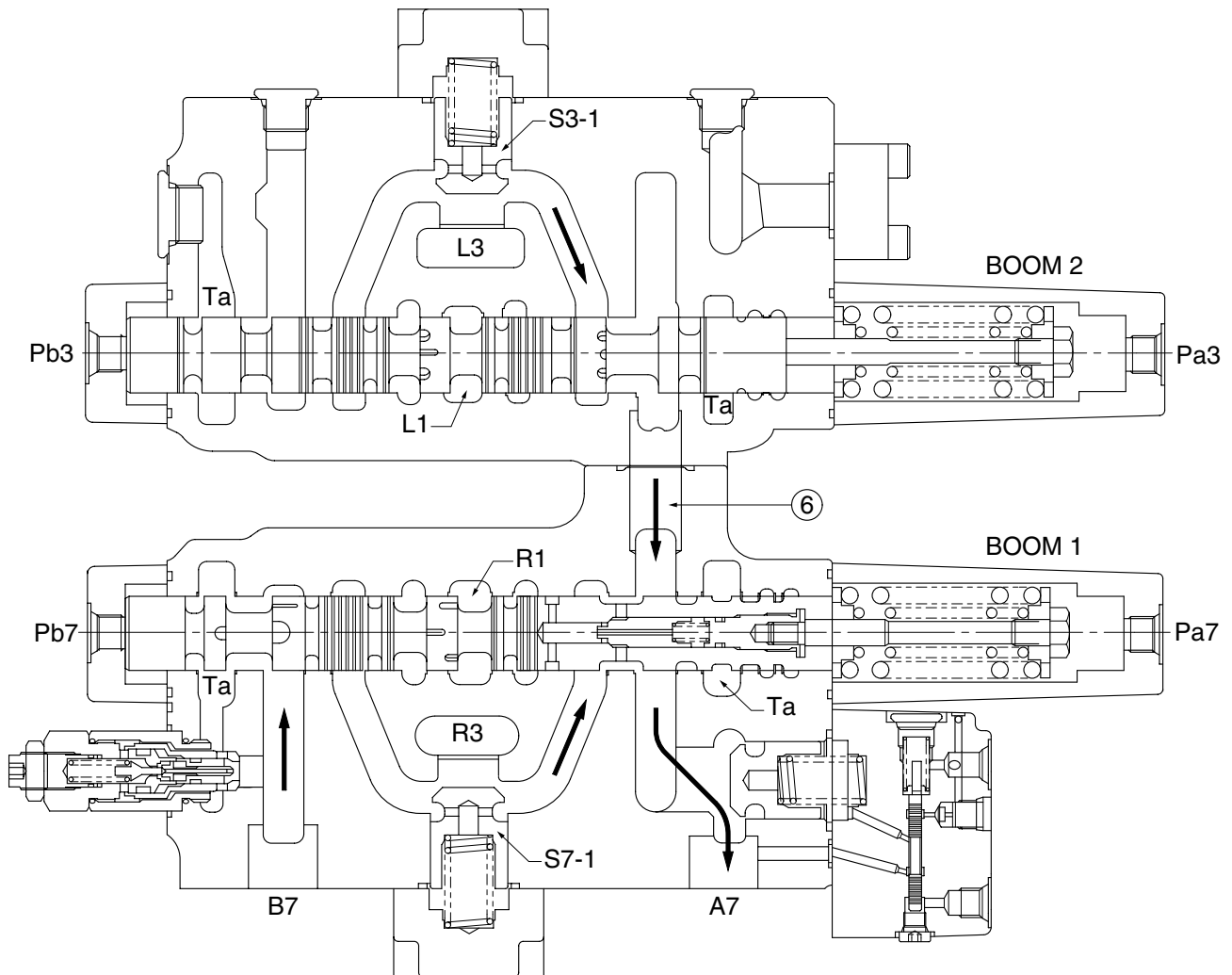

48092MC10

### (3) Boom down (recycling)

When the boom 1 spool is pushed to the right by the pilot pressure of port Pb7, the neutral passage (R1) is closed, the oil discharged from pump P2 flows into the port B7 via parallel passage (R3) and the load check valve (S7-1). At the same time, as the port pc2 is pressurizing, the spool (AD3) of anti-drift valve is pushed up, the pressure of spring chamber (AD5) is released and the poppet (AD1) is opened and then the oil from port A7 flows into the tank passage (Ta). Some of returned oil makes the poppet (S7-3) inside boom 1 spool to open and is connected to the passage (S7-2) and flows together into the port B7.

This prevents the cavitation of cylinder rod side.

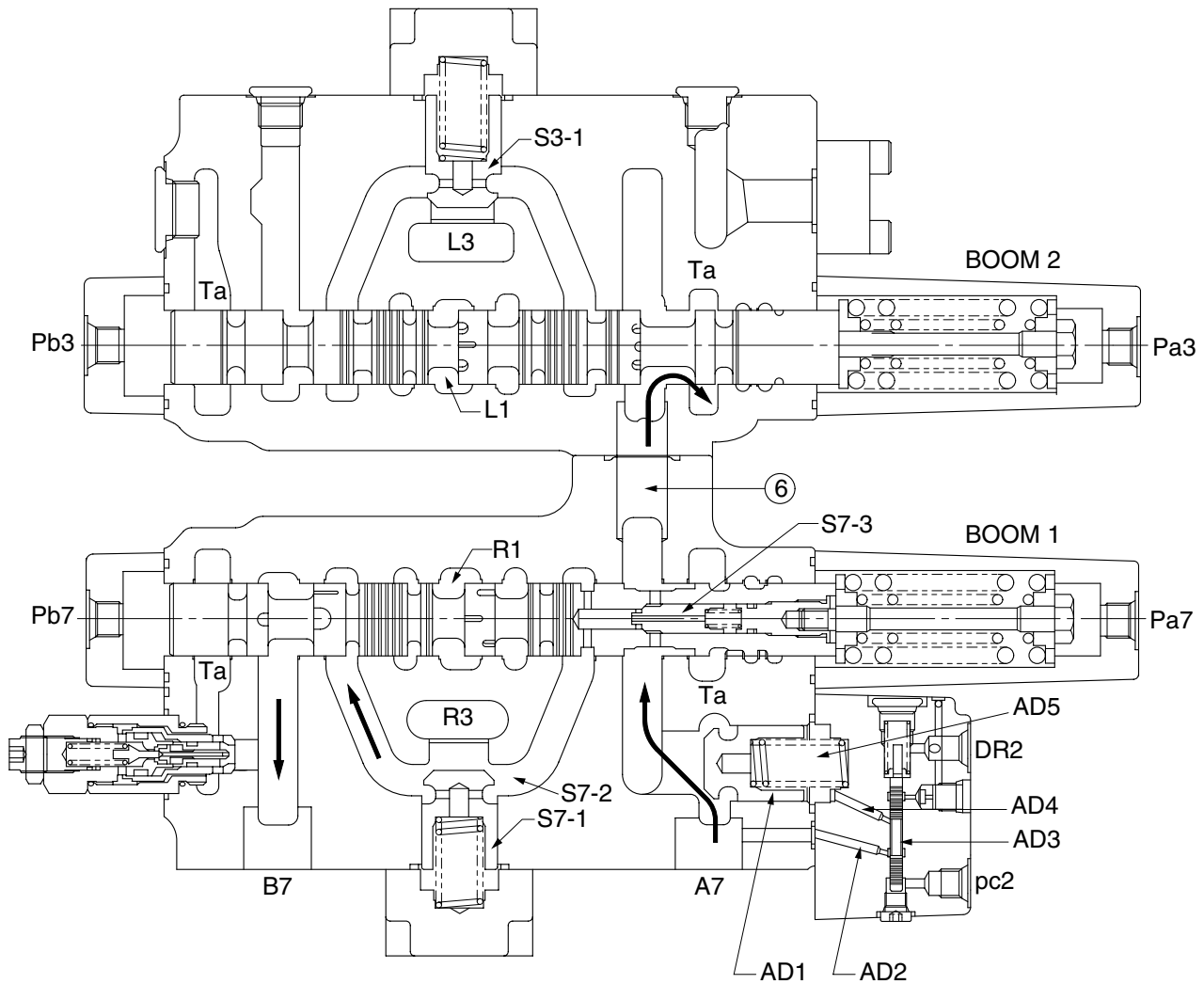

48092MC11

#### 4) SERVICE SPOOL

When the service spool is pushed to the left by the pilot pressure of port Pb4, the neutral passage (L1) is closed, the oil discharged from pump P1 flows into the port B4 via parallel passage (L3), the load check valve (S4-1) and passage (S4-2).

At the same time, as the port pa10 (see 2-25 page) is pressurizing and the bypass cut spool (R) is pushed, the oil discharged from pump P2 flows together into the port B7 via passage (11), poppet (S4-3). The oil returned from port A4 flows into the tank via the tank passage (Ta).

#### 5) BUCKET SPOOL

When the bucket spool is pushed to the left by the pilot pressure of port Pb8, the neutral passage (R1) is closed, the oil discharged from pump P2 flows into the port B8 via parallel passage (R3), the load check valve (S8-1) and passage (S8-2).

At the same time, as the port pa11 is pressurizing and the bypass cut spool (R) is pushed, the oil discharged from pump P1 flows together the passage (S8-2) via passage (7), poppet (S8-3).

The return oil from port A8 flows into the tank via the tank passage (Ta).

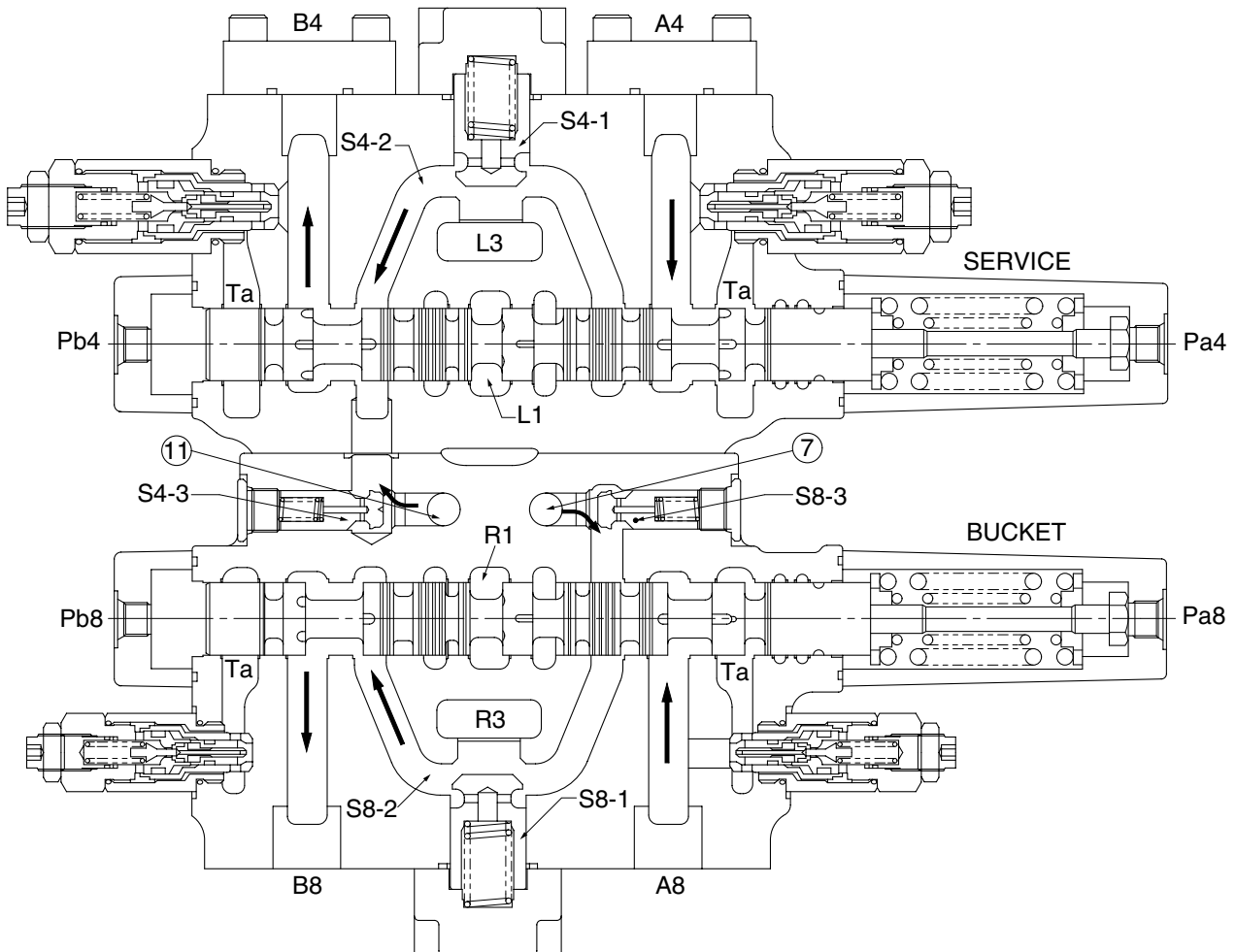

48092MC12A

## 6) ARM SPOOL

### (1) Arm out (flow summation)

When the arm 1 spool is pushed to the right by the pilot pressure of port Pb5, the oil discharged from pump P1 flows into the port B5 via neutral passage (L1), the load check valve (S5-1) and passage (S5-2).

When the arm 2 spool is pushed to the right by the pilot pressure of port Pb9, the oil discharged from pump P2 flows together the port B5 the passage (⑩) via the neutral passage (R1), the load check valve (S9-1) and passage (S9-2).

The return oil from port A5 flows into the tank via the tank passage (Ta).

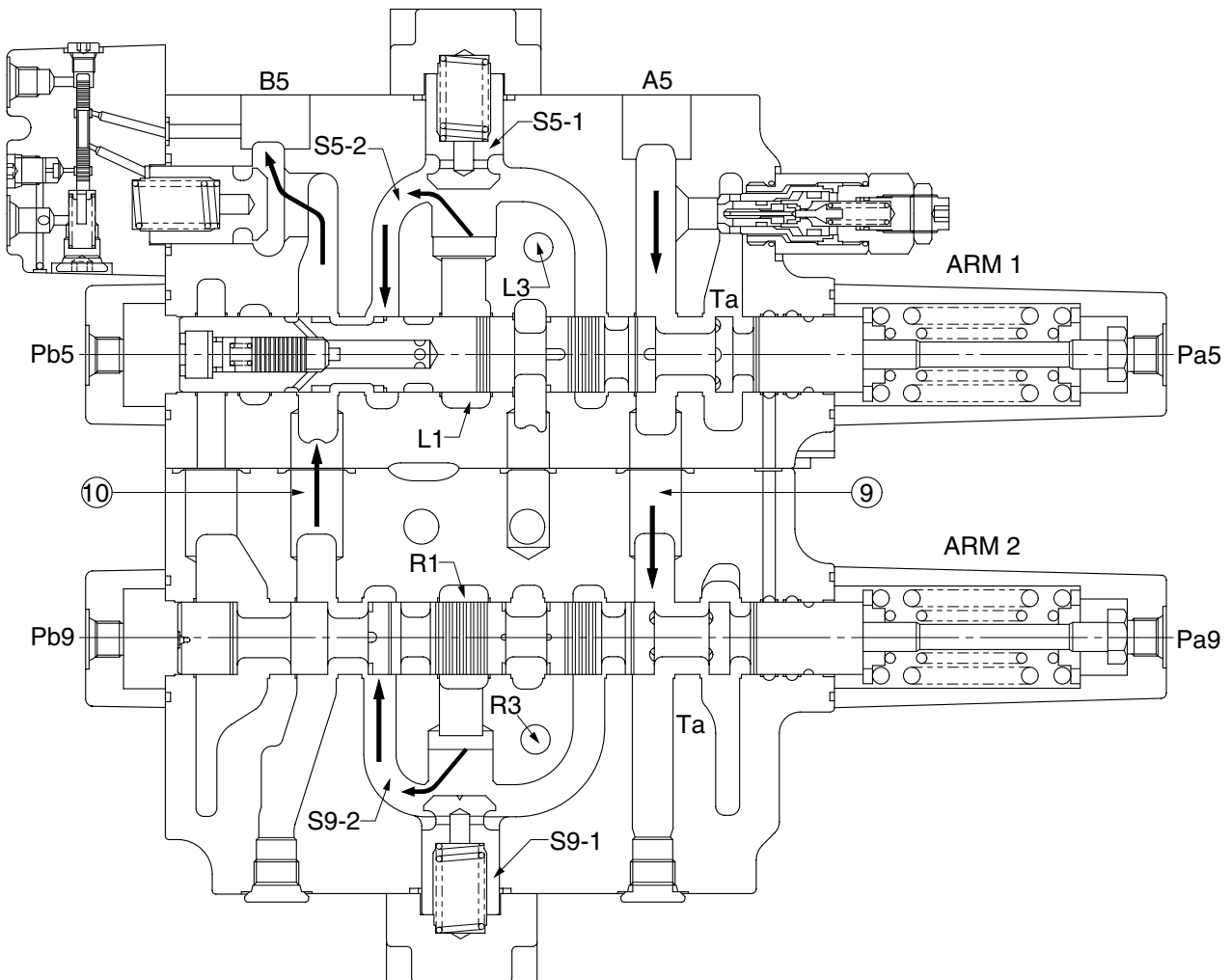

48092MC13

**(2) Arm in (flow summation)**

When the arm 1 spool is pushed to the left by the pilot pressure of port Pa5, the oil discharged from pump P1 flow into the port A5 via neutral passage (L1), the load check valve (S5-1) and passage (S5-2).

When the arm 2 spool is pushed to the left by the pilot pressure of port Pa9, the oil discharged from pump P2 flows together into the port A5 via neutral passage (R1), the load check valve (S9-1) and passage (S9-2).

At the same time, as the port pc1 is pressurizing and the spool (AD3) of anti-drift valve is pushed down, the pressure of spring chamber (AD5) is released and the poppet (AD1) is opened and then the oil returned from port B5 flows into the tank passage (Ta) through the passage (S5-4) inside arm 1 spool to open and is connected to the passage (S5-2) and flows together into the port A5, the cylinder speed is raised and also prevents the cavitation of bottom side.

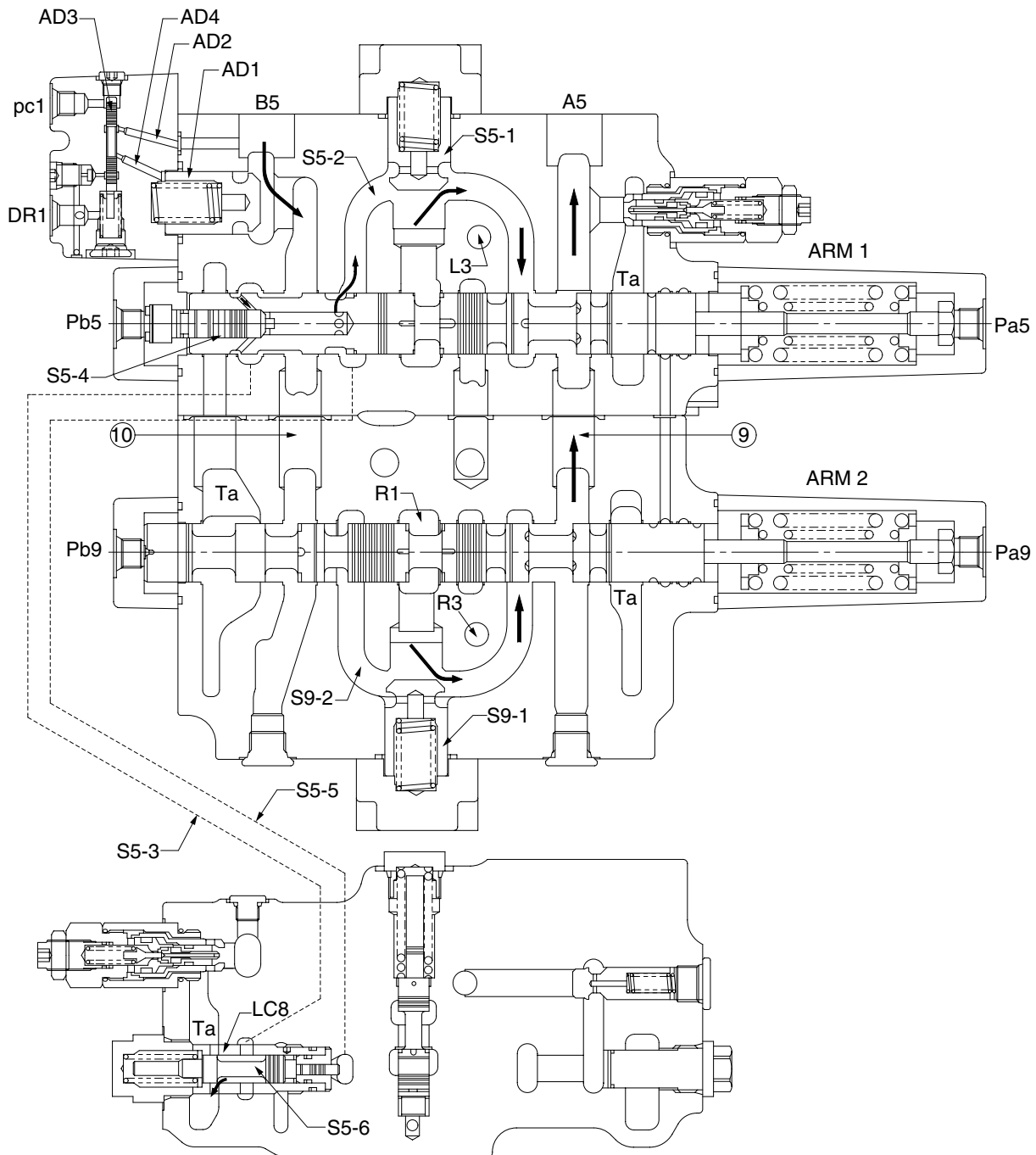

### (3) Arm recycling (arm in)

When the arm is at in position, the spool (S5-6) stroke against the passage (S5-2) pressure guided from the passage (S5-5) is changed according to the opening angle of arm recycling orifice (Lc8).

When the pressure of the passage (S5-2) is high and this stroke is increased, the opening angle of orifice (Lc8) become large. On the contrary, when the pressure of passage (S5-2) is low, this stroke is decreased, the opening angle of orifice (Lc8) become small.

Therefore, the flow rate for arm recycling is changed by the pressure in bottom side of arm cylinder.

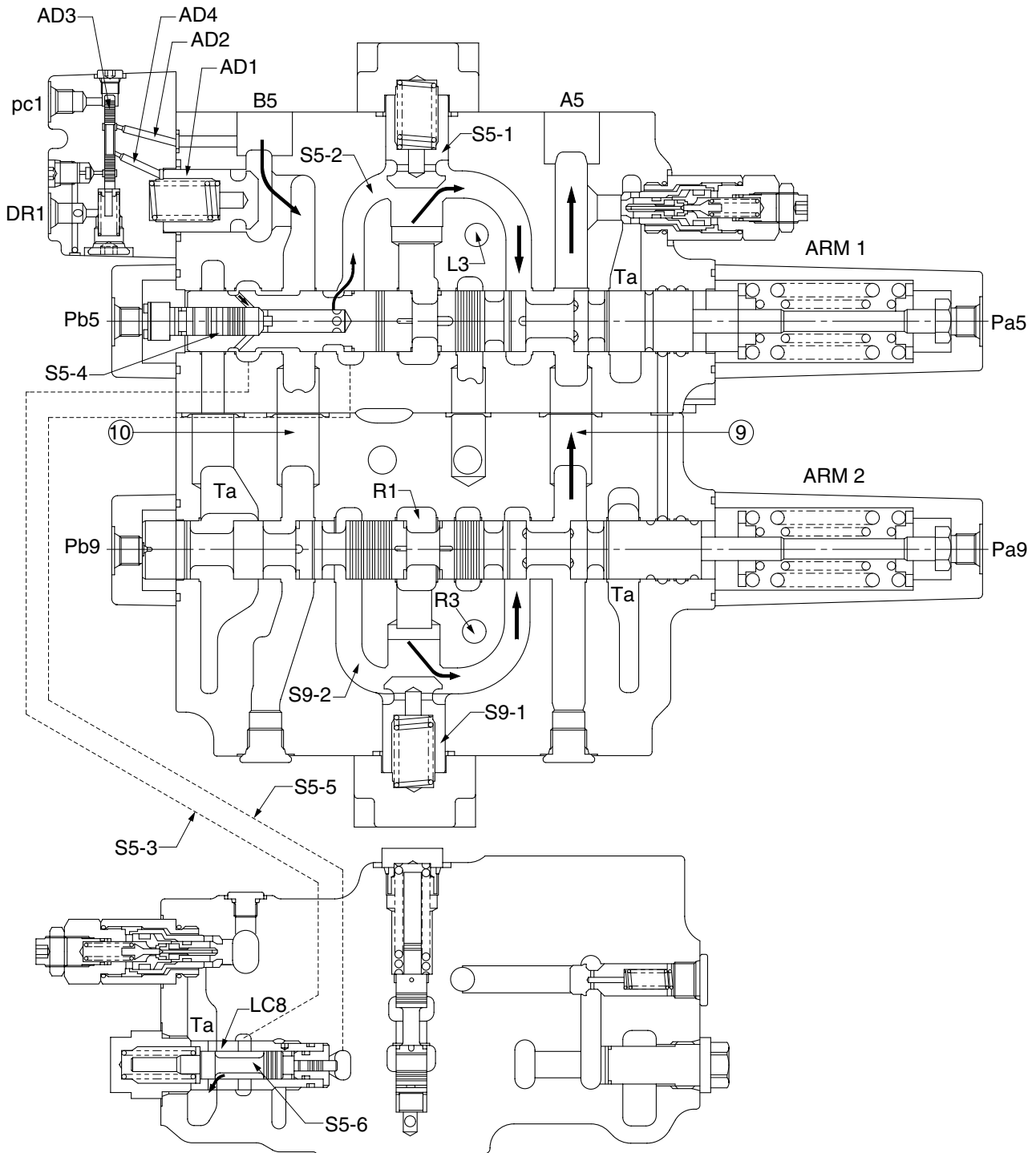

## 7) BYPASS CUT SPOOL

This valve is providing the bypass cut spool at the lowest stream of (upper stream of the low pressure relief valve) the neutral passage (L1, R1).

As the port pa10 (pa11) is pressurizing and the bypass cut spool (L, R) is pushed, the neutral passage (L1, R1) is closed. The oil discharged from port P1 flows together into the passage (S8-2, see 2-33 page) of bucket section via passage (⑦), poppet (S8-3) and the oil discharged from P2 port flows together into the passage (S4-2) of service section via the passage (⑪) and poppet (S4-3, see 2-33 page).

## 8) PARALLEL ORIFICE FOR ARM

The arm 1 and arm 2 section of this valve has orifices in the parallel circuit for arm. These orifices controls the speed of arm at combined operation.

The parallel circuit of arm 2 section is connected to the passage (S9-2, see 2-35) through orifice (Rc6) in the edge of the poppet (S9-3) from the parallel passage (R3), the parallel circuit of arm 1 section is connected to the passage (S5-2, see 2-35) through orifice (Lc9) in the edge of the poppet (S5-8) from the parallel passage (L3).

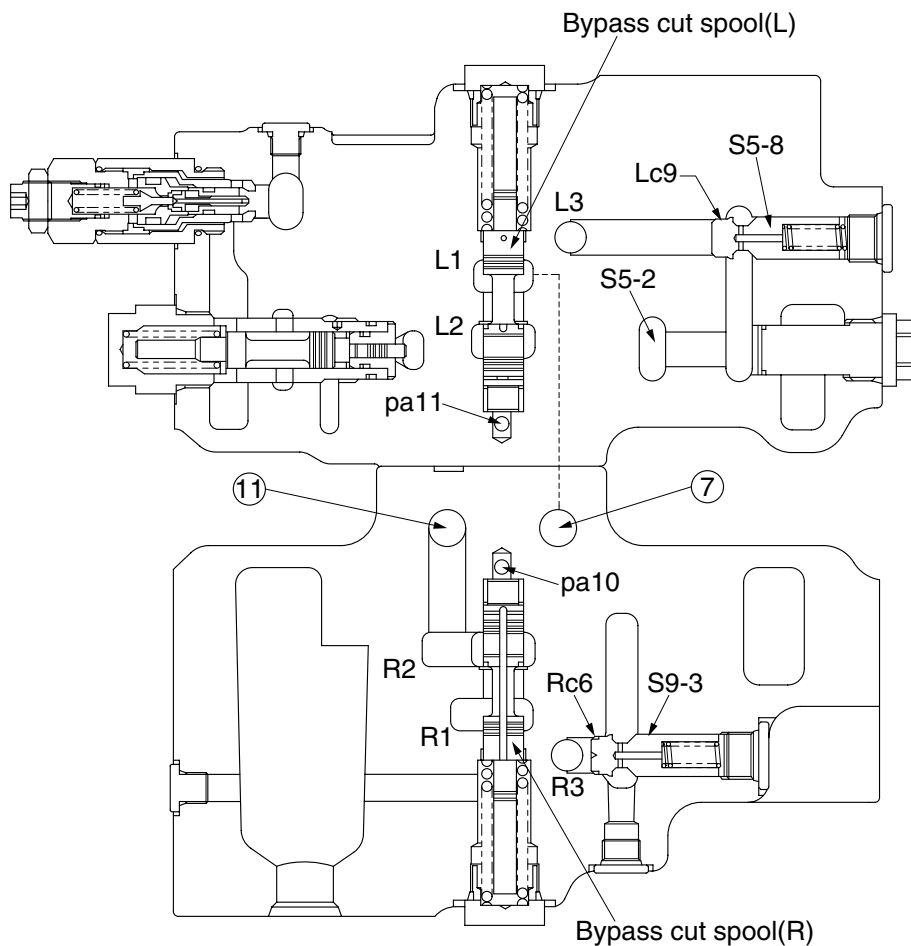

48092MC15

## 9) RELIEF VALVE

### (1) Main relief valve

The oil discharged from P1 port via the poppet (LP) and the oil discharged from P2 port via the poppet (RP) flow into the main relief valve through the passage (3).

When the main relief valve is operating, the maximum pressure of pump P1, P2 is controlled.

### (2) Overload relief valve

Overload relief valves are provided each cylinder ports of boom1, arm1 and bucket. These prevent the abnormal high pressure of actuators by external force.

Also, when the pressure of cylinder ports create back pressure, this valve opens allowing oil from tank to cylinder port; and then prevents cavitation.

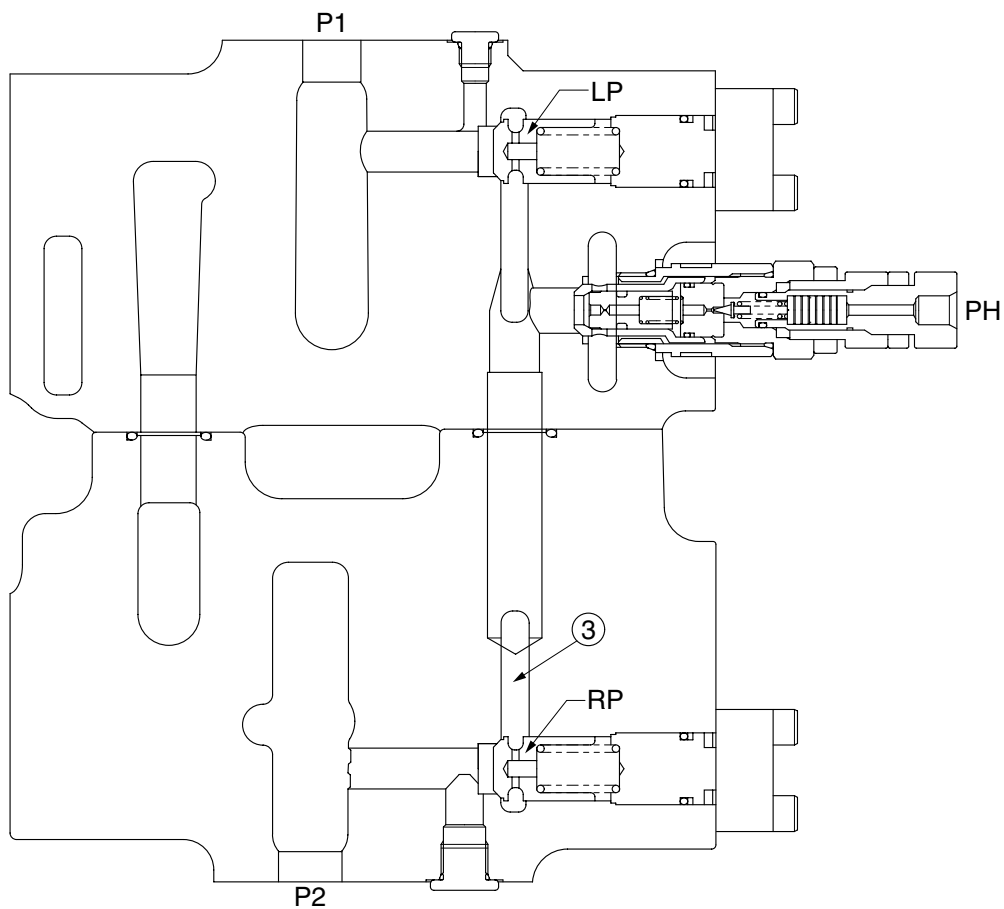

48092MC16

## 4. COMBINED OPERATION

### 1) TRAVEL COMBINED OPERATION

- ① While travel (forward, reverse and pivot turn) and front attachment (except travel section) functions are operated, the oil discharged from port PP is cut via land (Lc4, Lc7, Rc3, Rc5) and blocked from signal land except travel section to tank passage (Ta), the pressure of signal passage rises to the relief setting pressure of pilot pump and the straight travel spool is pushed to the left by raising of signal pressure and also, the pressure of port PT, PA port rises.

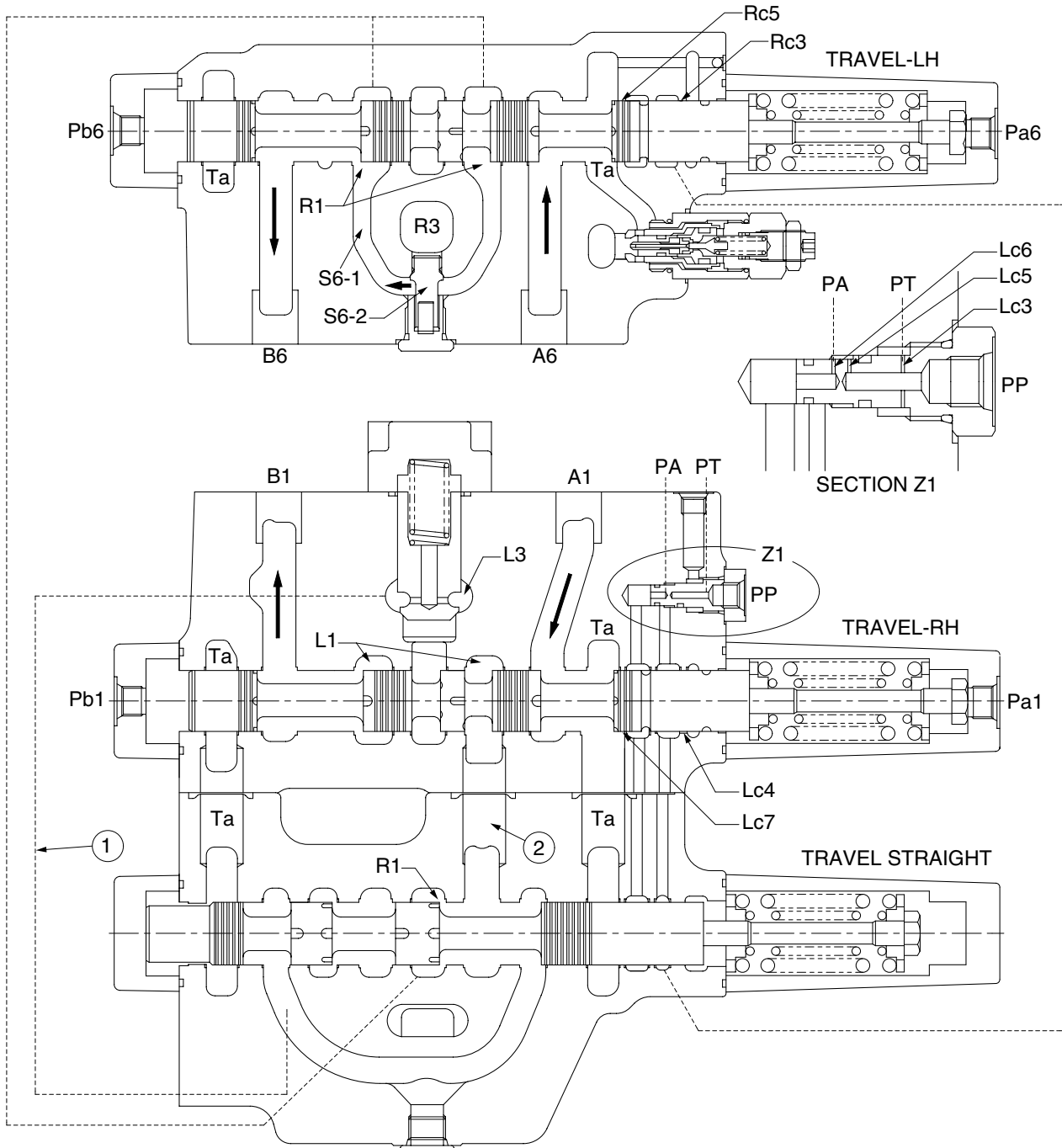

- ② When the straight travel spool is operated, the oil discharged from port P1 flows into RH travel section through the neutral passage (L1) and also flows into LH travel section via the neutral passage (R1) and passage (②). The oil discharged from port P2 flows into the parallel passage (L3) via passage (①).
- ③ In case the load pressure of the section except travel is higher than that of the RH travel section, the partial oil of discharged from port P2 pushes open the poppet (S6-2) and flows together into the passage (S6-1) through the orifice at the edge of poppet. The travel (LH, RH) is operated by the discharged oil from port P1 and the other actuators are operated by the discharged oil from port P2. Thus, when travel and front attachment functions are operated simultaneously, keeps the straight travel.

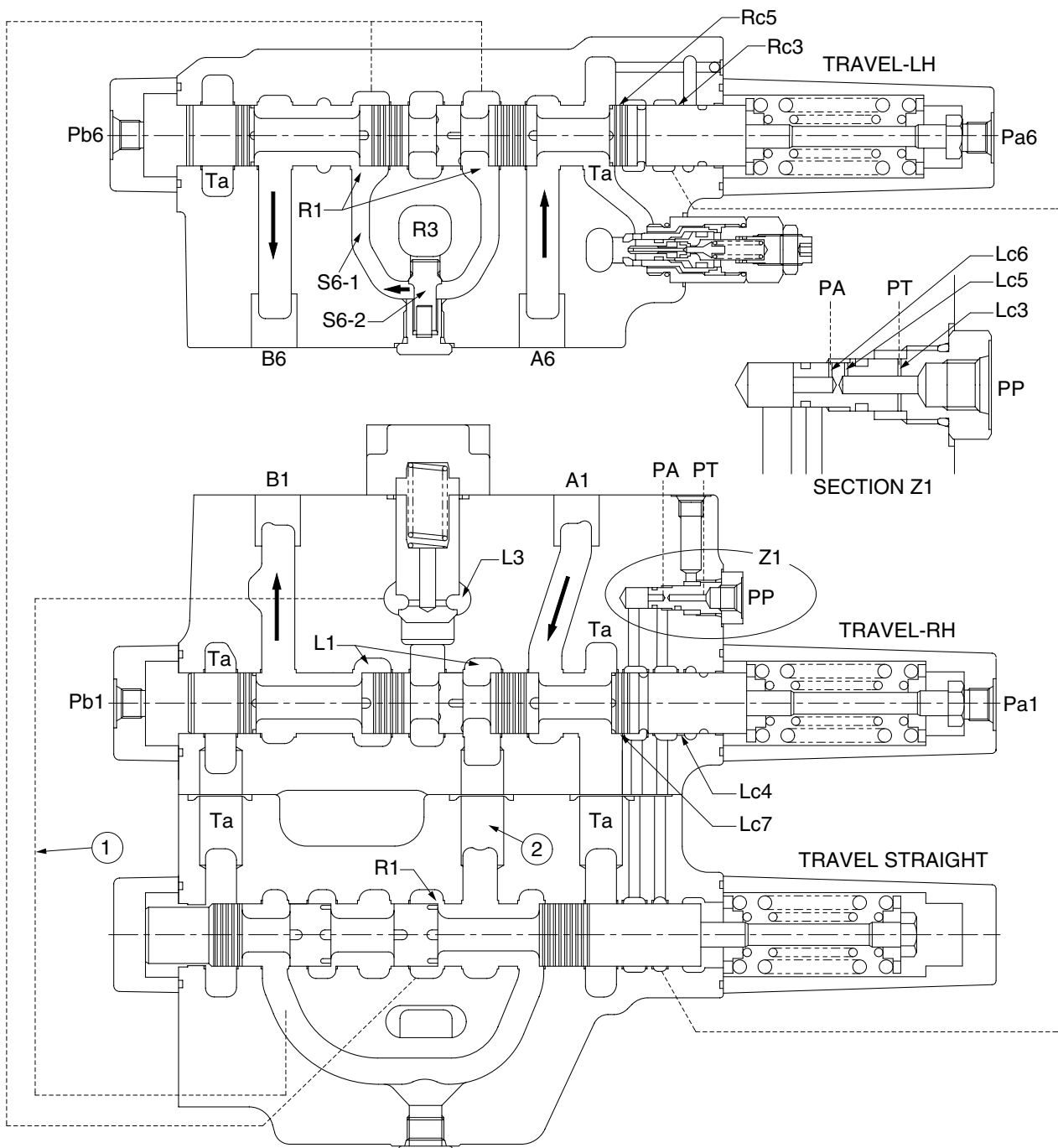

48092MC17

## 2) SWING COMBINED OPERATION

When swing and boom up functions are operated, the poppet (S2-1) is seated by pressure of port pc6 and the poppet (S2-3) only opened and the supply pressure of the parallel passage (L3) is rises by orifice (S2-4).

As a result, boom and swing simultaneous operation is ensured even if lower load of swing section.

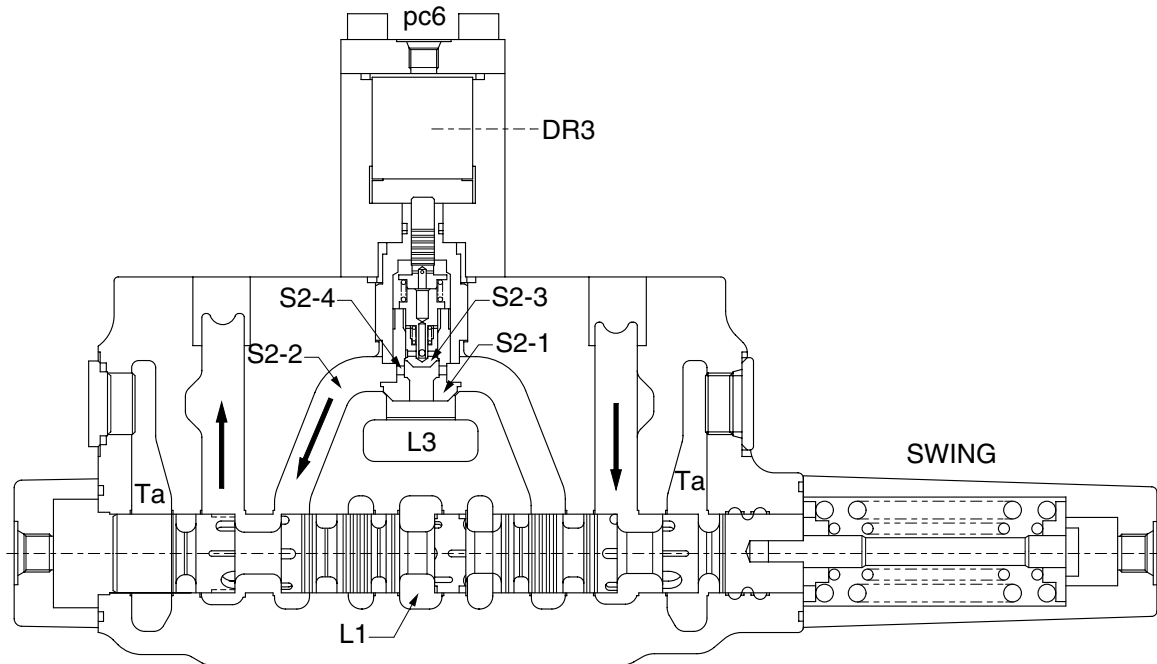

48092MC18

## 5. ANTI-DRIFT VALVE

The anti-drift valve is provided the boom bottom and arm rod side of cylinder port for prevention of self drifting by boom weight or bucket loads.

### 1) WHEN NEUTRAL

The oil from cylinder port flows into spring chamber (AD5) via passage (AD2), the around of spool (AD3) and passage (AD4).

Because of the difference of poppet area and spring force, the poppet (AD1) is seated certainly.

### 2) WHEN BOOM UP OR ARM OUT

The oil from pump flows into cylinder by pushes open the poppet (AD1).

### 3) WHEN BOOM DOWN OR ARM IN

The spool (AD3) is pushed down by the pressure of pc1 (pc2).

Then the oil of spring chamber (AD5) flows into the drain port DR1 (DR2) and pushes open the poppet (AD1).

As a result, the oil from the cylinder port returns to tank passage (Ta).

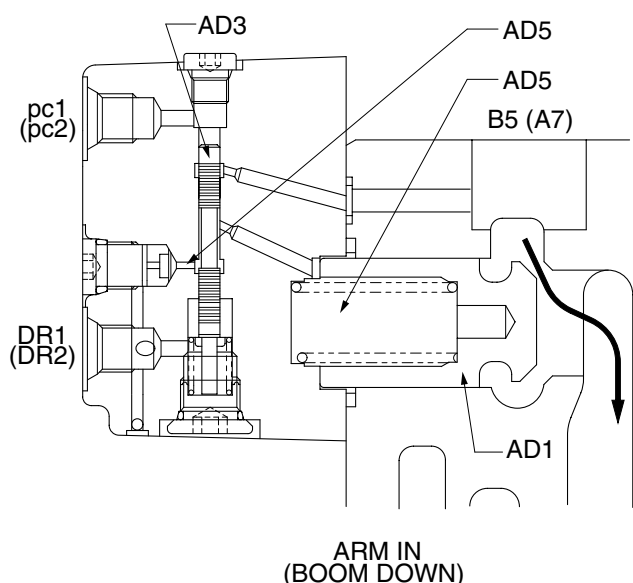
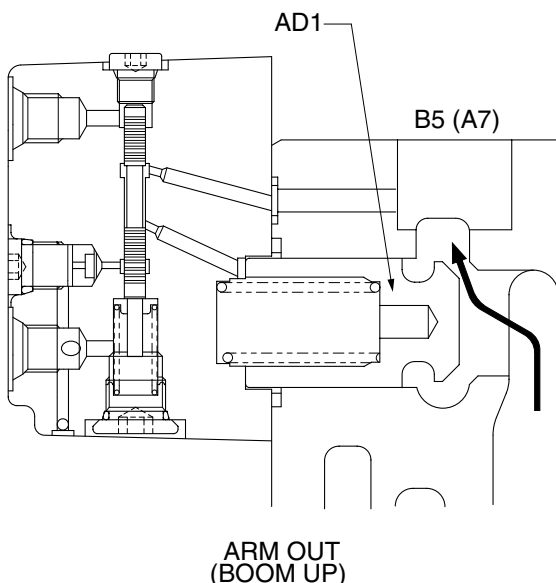
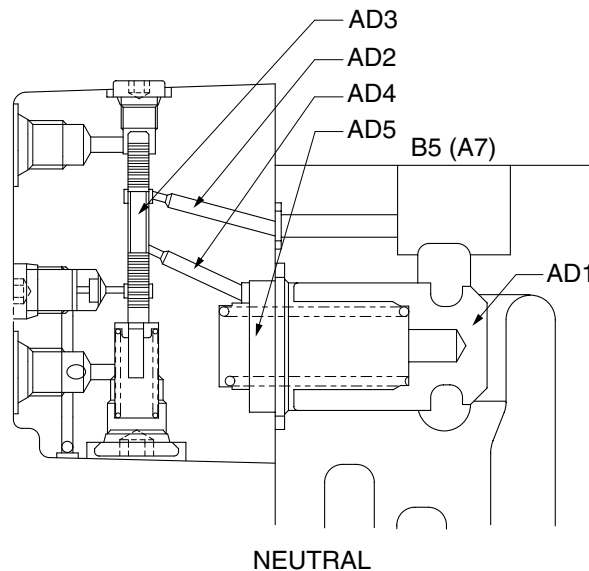

48092MC19

## 6. RELIEF VALVE OPERATION

### 1) MAIN RELIEF VALVE

- (1) This relief valve is built-in between the neutral passage (HP) and low pressure passage (LP), and the pressure oil fills up chamber (D) inside via orifice of main poppet (C). Thus the sleeve (E) and the main poppet (C) are securely seated by difference area of A and B.

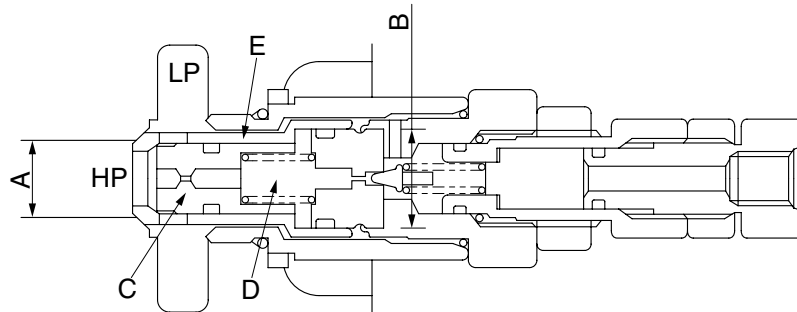

48092MC20

- (2) When the pressure in neutral passage(HP) reaches the setting force of spring, pilot poppet(F) is opened. The oil flows around poppet and into the low pressure passage(LP) via hole(G).

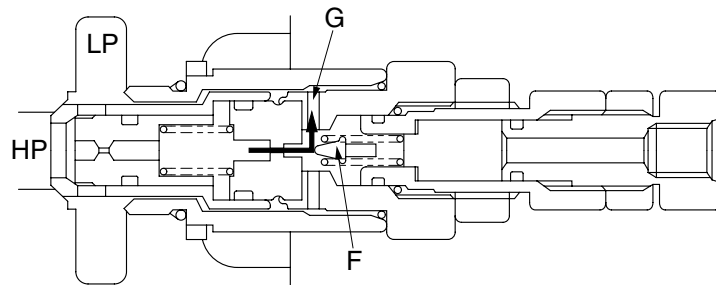

48092MC21

- (3) When above flow is formed, the pilot poppet is opened; the pressure of chamber(D) drops, the main poppet(C) is opened and then the oil directly flows into the low pressure passage(LP).

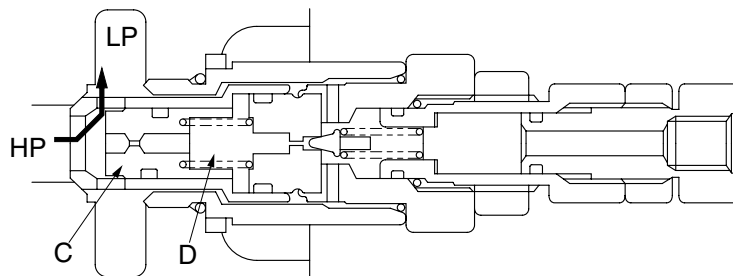

48092MC22

- (4) High pressure setting pilot signal(Pi) : ON

The piston(H) moves to left by pilot pressure(Pi); set pressure of spring rises, making high pressure setting.

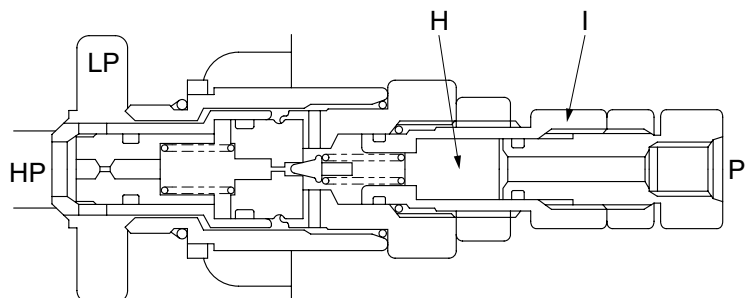

48092MC23

## 2) OVERLOAD RELIEF VALVE

(1) This relief valve is built-in the cylinder port (HP) and the low pressure (LP), and the pressure oil fills up chamber (G) inside via hole of piston (C).

Thus the sleeve (K) and the main poppet (D) are securely seated by difference area of A and B.

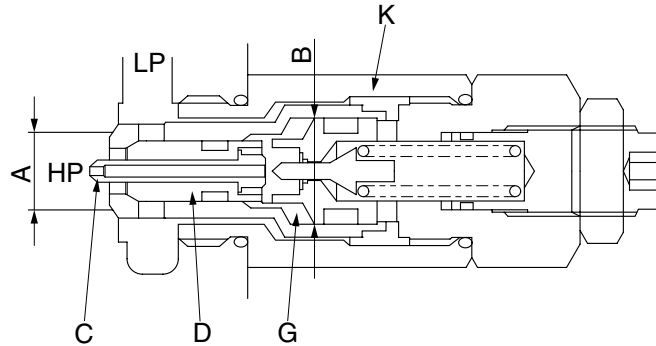

48092MC24

(2) When the pressure in cylinder port (HP) reaches the setting force of spring, the pilot poppet (E) is opened.

The oil flows around poppet and into the low pressure passage (LP) via hole (H).

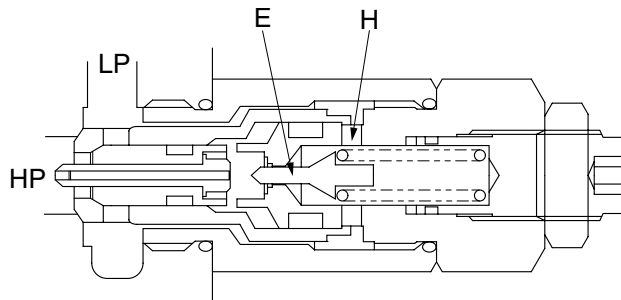

48092MC25

(3) When above flow is formed, the pilot poppet (E) is opened.

The pressure drops before and behind orifice (I); piston (C) moves to right and the piston (C) is seated at the tip of poppet (E).

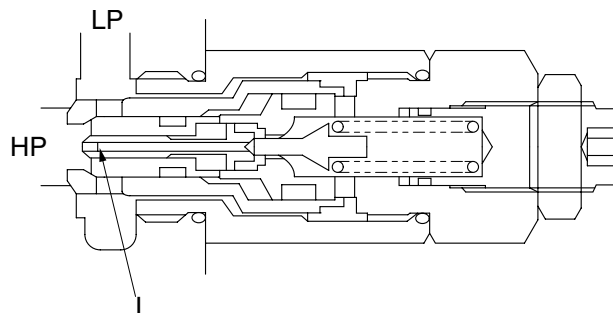

48092MC26

- (4) The oil flow from the high pressure passage (HP) to the poppet (D) behind is only around poppet and orifice (F); then the high pressure passage (HP) is higher than the poppet (D) behind pressure. Thus the poppet (D) is pushed open and the oil directly flows into low pressure passage(LP).

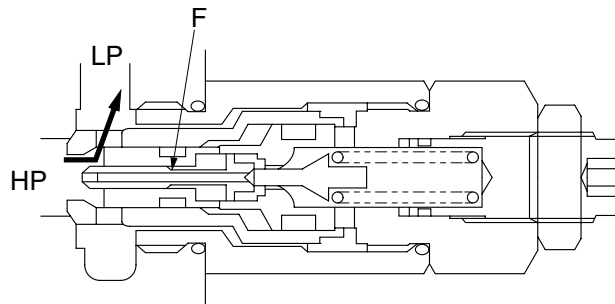

48092MC27

**(5) Make up operation**

This relief valve is built-in the cylinder port (HP) and the low pressure passage (LP), and the pressure oil fills up chamber (G) inside via hole of piston (C).

Thus the sleeve (K) and the main poppet (D) are securely seated by difference area of A and B.

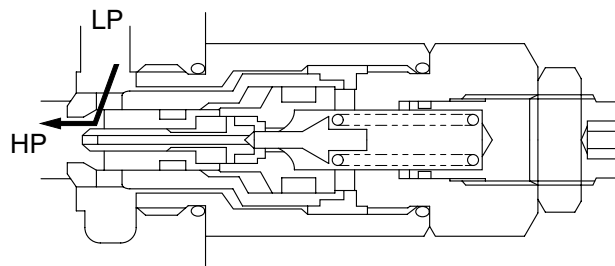

48092MC28

### 3) LOW PRESSURE RELIEF VALVE

#### (1) When pump does not operational

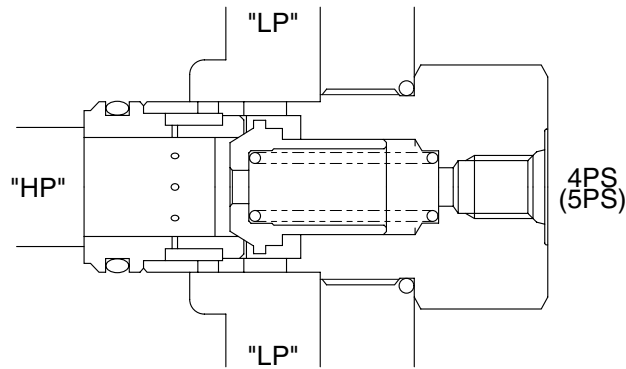

48092MC29

#### (2) When spool neutral

The neutral passage (HP) oil flows into the low pressure passage (LP) via signal orifice (S). The signal port 4Ps (5Ps) pressure is raised by negative control orifice (A).

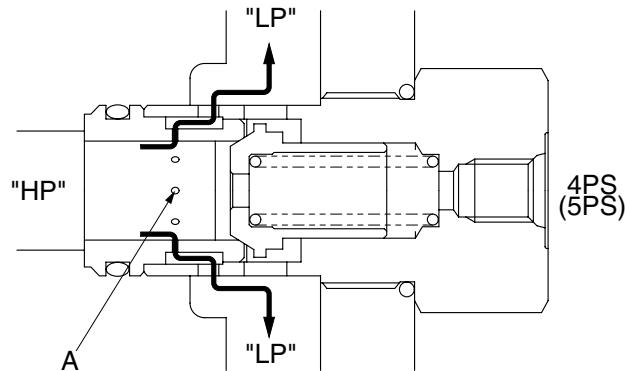

48092MC30

#### (3) Operation of low pressure relief

When the oil pressure neutral passage (HP) reaches the setting force of spring, the poppet is pushed open; the oil directly flows through passage (HP) to passage (LP) in order to prevent abnormal pressure.

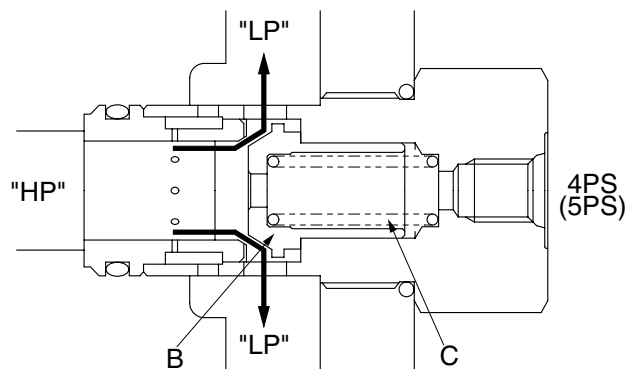

48092MC31