

## SECTION 2 STRUCTURE AND FUNCTION

Group 1 Pump Device .....	2-1
Group 2 Main Control Valve .....	2-22
Group 3 Swing Device .....	2-47
Group 4 Travel Device .....	2-58
Group 5 RCV Lever .....	2-65
Group 6 RCV Pedal .....	2-72

# SECTION 2 STRUCTURE AND FUNCTION

## GROUP 1 PUMP DEVICE

### 1. STRUCTURE

The pump device consists of main pump, regulator.

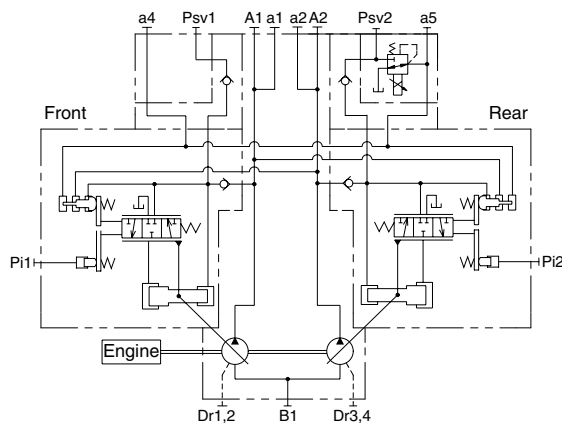
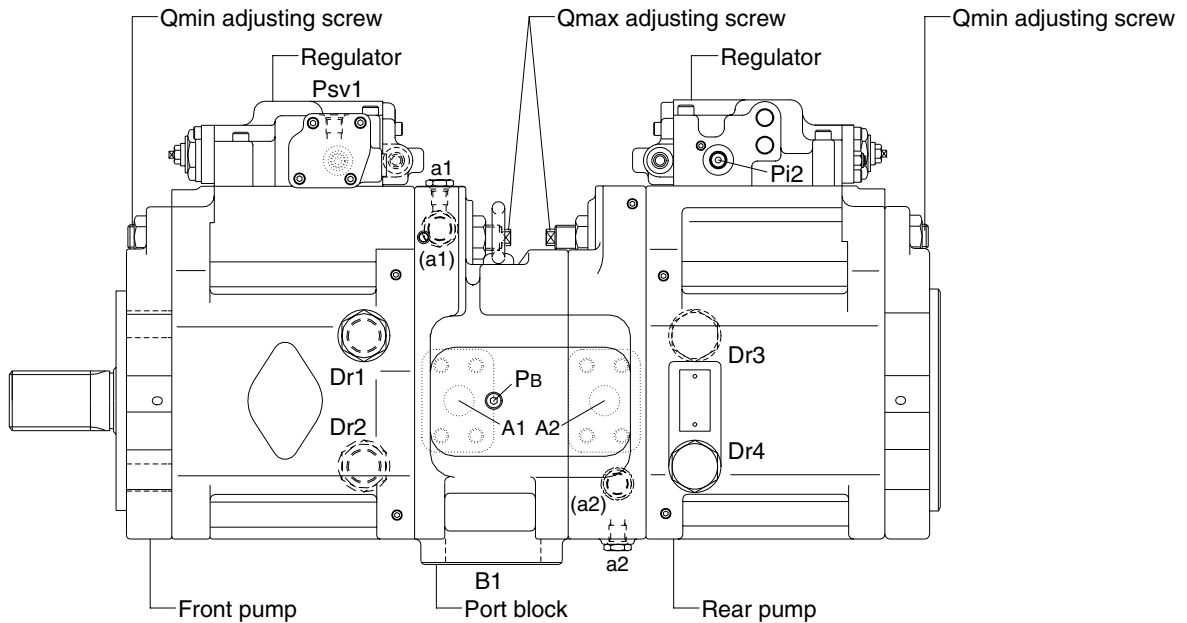
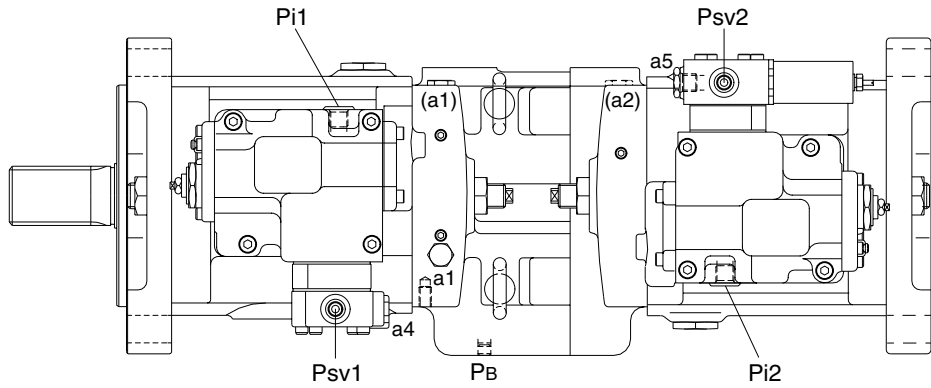

Hydraulic circuit

48092MP01A

Port	Port name	Port size
A1,A2	Delivery port	SAE6000psi 1"
B1	Suction port	SAE2500psi 3"
Dr1~Dr4	Drain port	PF 3/4 - 23
Pi1,Pi2	Pilot port	PF 1/4 - 15
Psv1, Psv2	Servo assist port	PF 1/4 - 15
a1, a2, a4, a5	Gauge port	PF 1/4 - 15
Pb	Gauge port	PT 1/8

## 1) MAIN PUMP(1/2)

The main pump consists of two piston pumps (front & rear) and valve block.

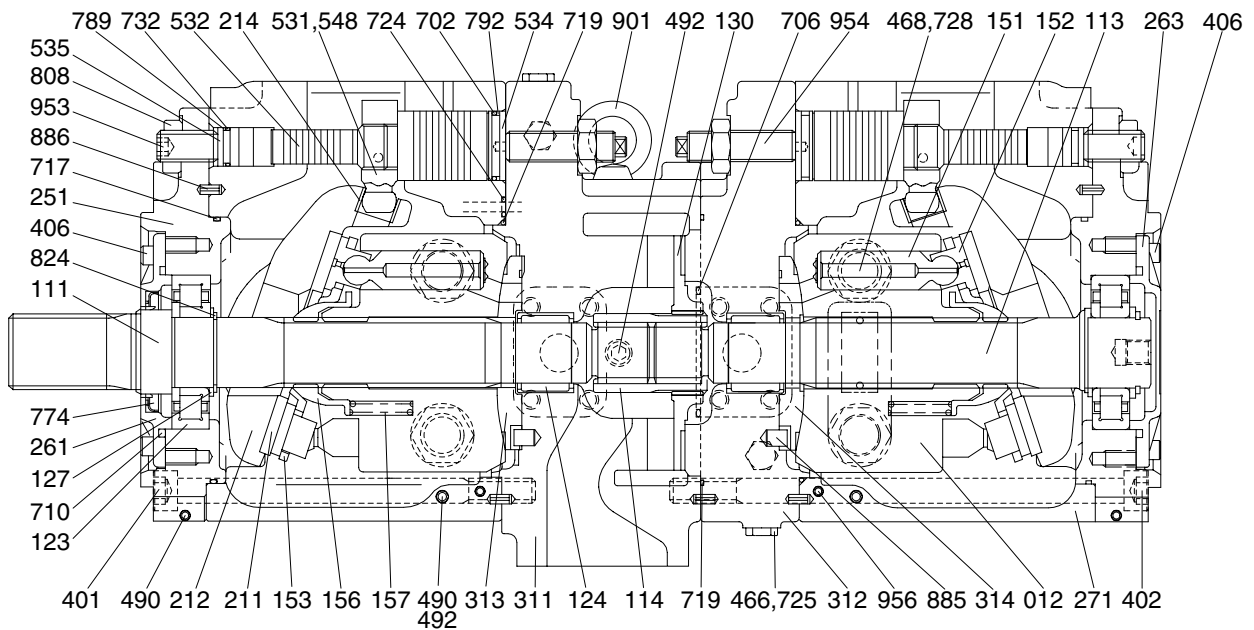

48092MP02

012	Cylinder block	271	Pump casing	710	O-ring
111	Drive shaft(F)	311	Valve cover(F)	717	O-ring
113	Driven shaft(R)	312	Valve cover(R)	719	O-ring
114	Coupling	313	Valve plate(R)	724	O-ring
123	Roller bearing	314	Valve plate(L)	725	O-ring
124	Needle bearing	401	Hexagon socket bolt	728	O-ring
127	Spacer	402	Hexagon socket bolt	732	O-ring
130	Booster	406	Hexagon socket bolt	774	Oil seal
151	Piston	466	VP Plug	789	Back up ring
152	Shoe	468	VP Plug	792	Back up ring
153	Set plate	490	VP Plug	808	Hexagon head nut
156	Bushing	492	VP Plug	824	Snap ring
157	Cylinder spring	531	Tilting pin	885	Pin
211	Shoe plate	532	Servo piston	886	Spring pin
212	Swash plate	534	Stopper(L)	901	Eye bolt
214	Bushing	535	Stopper(S)	953	Set screw
251	Support plate	548	Feed back pin	954	Set screw
261	Seal cover(F)	702	O-ring	956	Set screw
263	Seal cover(R)	706	O-ring		

## 2) FRONT REGULATOR (1/2)

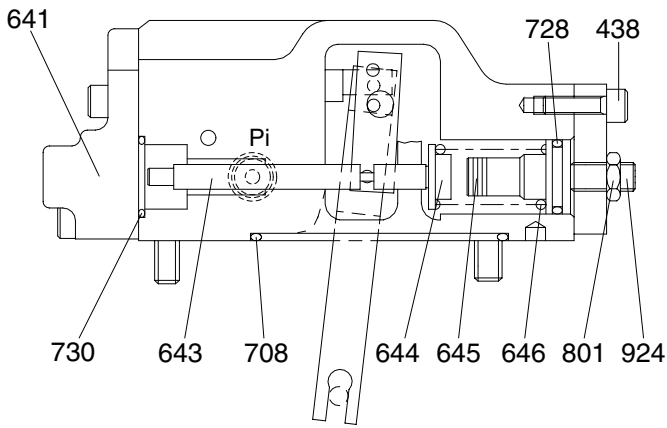
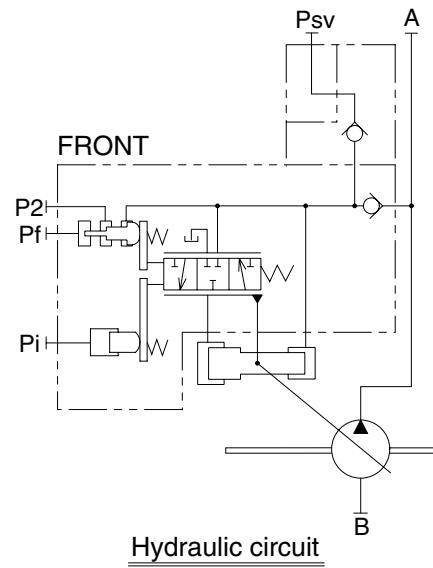
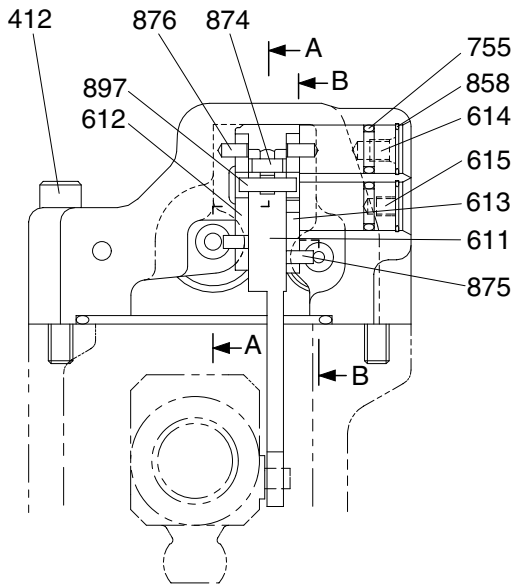

**SECTION B-B**

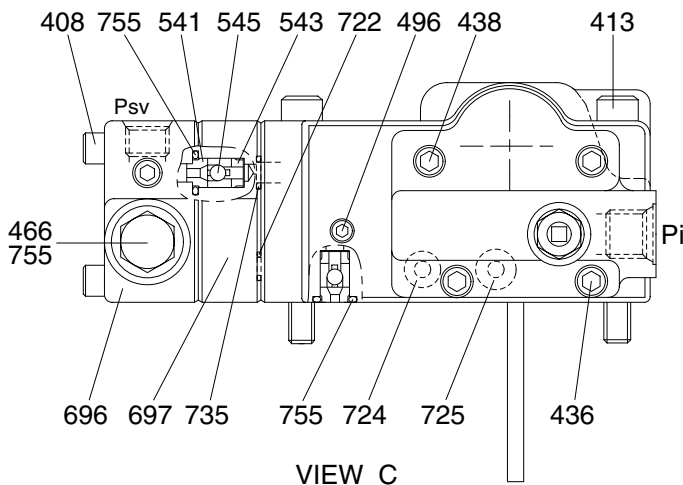

**VIEW C**

Port	Port name	Port size
Pi	Pilot port	PF 1/4 - 15
Psv	Servo assist port	PF 1/4 - 15
P2	Companion delivery port	-
Pf	Powershift port	-

48092RG01

## FRONT REGULATOR (2/2)

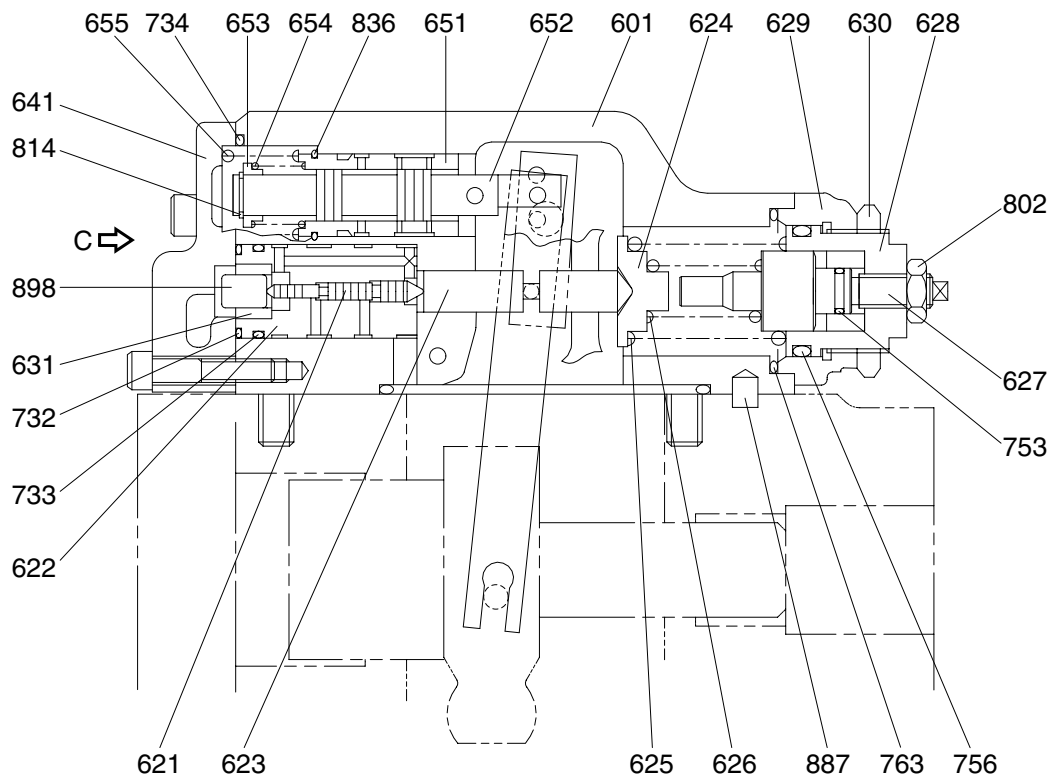

SECTION A-A

48092RG02

408 Hexagon socket screw	627 Adjust stem (C)	728 O-ring
412 Hexagon socket screw	628 Adjust screw (C)	730 O-ring
413 Hexagon socket screw	629 Cover (C)	732 O-ring
436 Hexagon socket screw	630 Lock nut	733 O-ring
438 Hexagon socket screw	631 Sleeve, pf	734 O-ring
466 Plug	641 Pilot cover	735 O-ring
496 Plug	642 Adjust screw (QMC)	753 O-ring
541 Seat	643 Pilot piston	755 O-ring
543 Stopper	644 Spring seat (Q)	756 O-ring
545 Steel ball	645 Adjust stem (Q)	763 O-ring
601 Casing	646 Pilot spring	801 Nut
611 Feed back lever	651 Sleeve	802 Nut
612 Lever (1)	652 Spool	814 Snap ring
613 Lever (2)	653 Spring seat	836 Snap ring
614 Center plug	654 Return spring	858 Snap ring
615 Adjust plug	655 Set spring	874 Pin
621 Compensator piston	696 Port cover	875 Pin
622 Piston case	697 Check valve plate	876 Pin
623 Compensator rod	708 O-ring	887 Pin
624 Spring seat (C)	722 O-ring	897 Pin
625 Outer spring	724 O-ring	898 Pin
626 Inner spring	725 O-ring	924 Set screw

### 3) REAR REGULATOR (1/2)

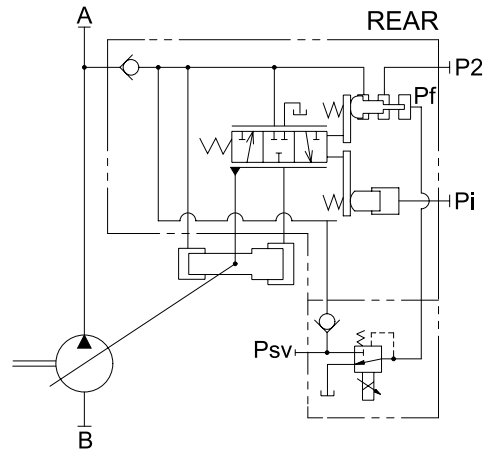
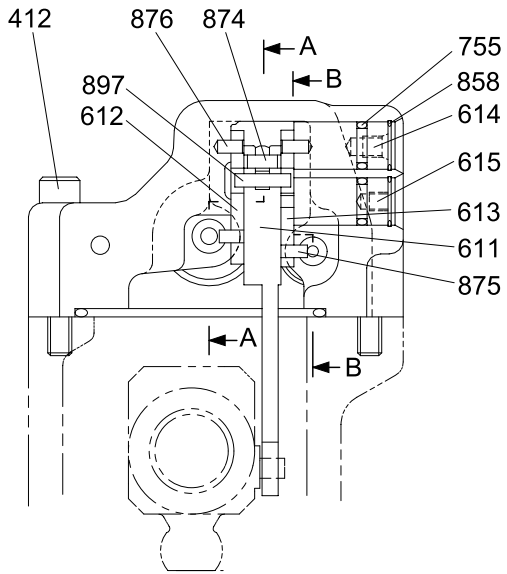

Hydraulic circuit

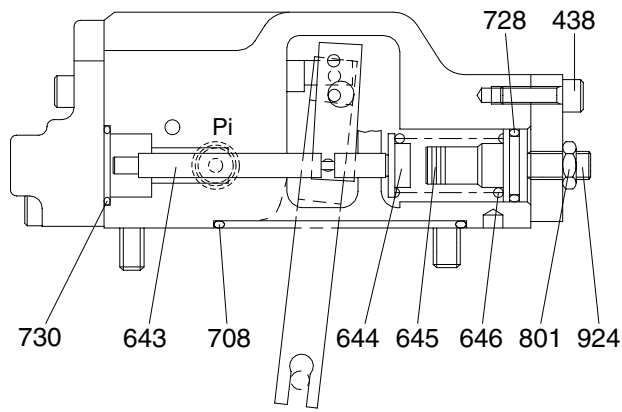

SECTION B-B

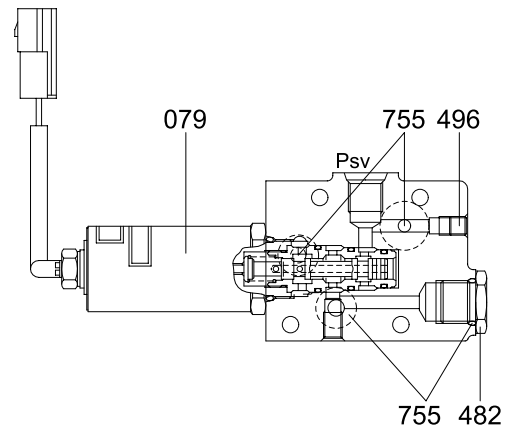

SECTION D-D

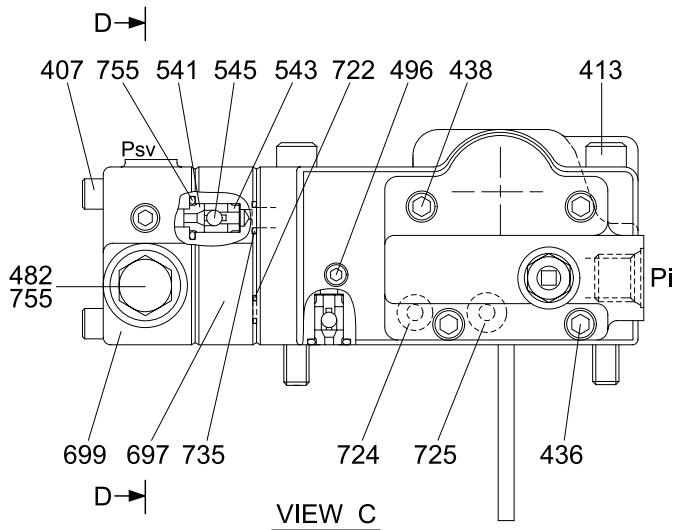

VIEW C

Port	Port name	Port size
Pi	Pilot port	PF 1/4 - 15
Psv	Servo assist port	PF 1/4 - 15
P2	Companion delivery port	-
Pf	Powershift port	-

48092RG03

## REAR REGULATOR (2/2)

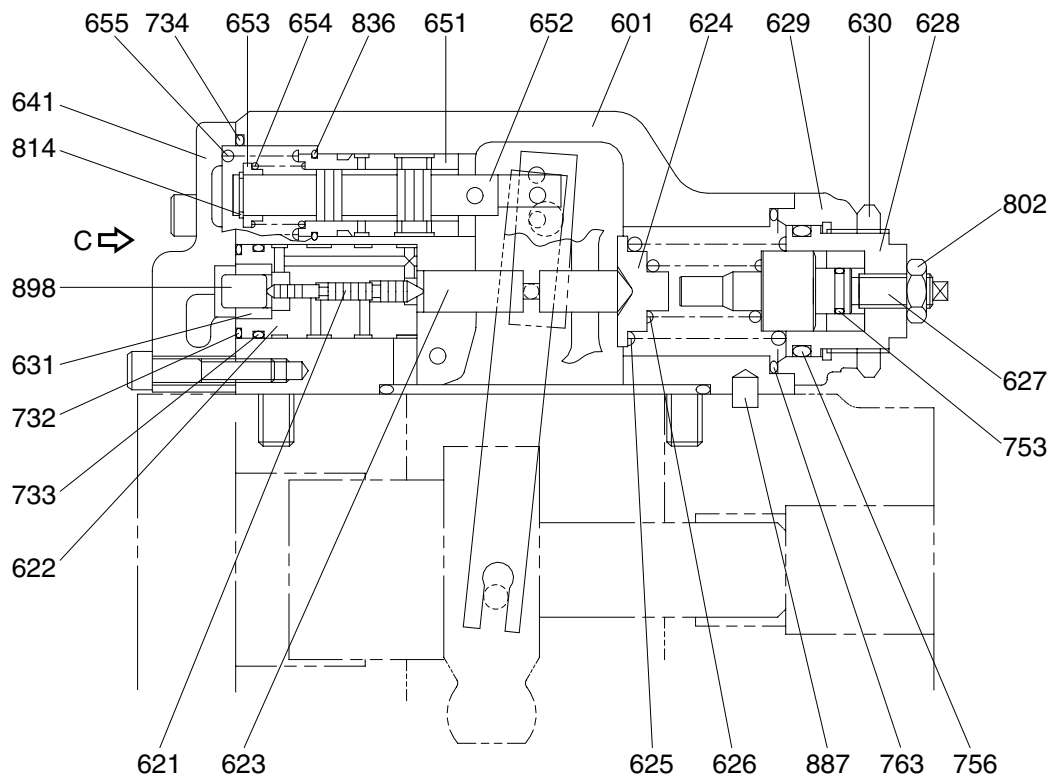

SECTION A-A

48092RG02

079	EPPR valve	626	Inner spring	728	O-ring
407	Hexagon socket screw	627	Adjust stem(C)	730	O-ring
412	Hexagon socket screw	628	Adjust screw(C)	732	O-ring
413	Hexagon socket screw	629	Cover(C)	733	O-ring
436	Hexagon socket screw	630	Lock nut	734	O-ring
438	Hexagon socket screw	631	Sleeve, pf	735	O-ring
482	Plug	641	Pilot cover	753	O-ring
496	Plug	643	Pilot piston	755	O-ring
541	Seat	644	Spring seat(Q)	756	O-ring
543	Stopper	645	Adjust stem(Q)	763	O-ring
545	Steel ball	646	Pilot spring	801	Nut
601	Casing	651	Sleeve	802	Nut
611	Feed back lever	652	Spool	814	Snap ring
612	Lever(1)	653	Spring seat	836	Snap ring
613	Lever(2)	654	Return spring	858	Snap ring
614	Center plug	655	Set spring	874	Pin
615	Adjust plug	697	Check valve plate	875	Pin
621	Compensator piston	699	Port cover	876	Pin
622	Piston case	708	O-ring	887	Pin
623	Compensator rod	722	O-ring	897	Pin
624	Spring seat(C)	724	O-ring	898	Pin
625	Outer spring	725	O-ring	924	Set screw

#### 4) GEAR PUMP (1/2)

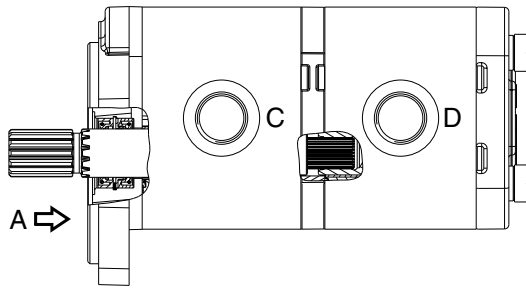

REAR VIEW

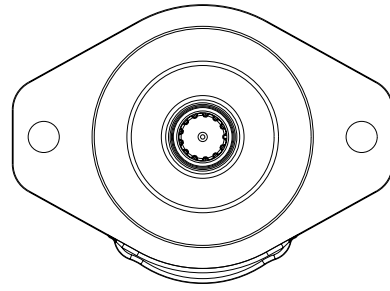

VIEW A

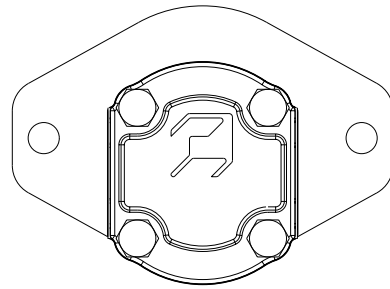
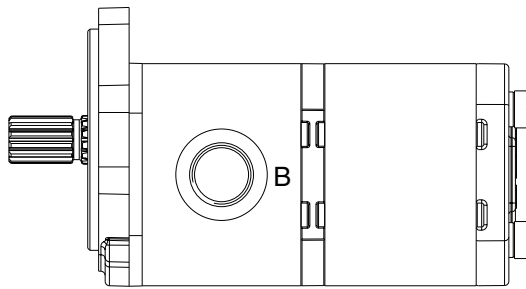

Port	Name	Size
B	Suction port	1 1/16"-12UN
C	Delivery port (fan motor)	7/8"-14UNF
D	Delivery port (pilot line)	7/8"-14UNF

48092GP02A

## GEAR PUMP (2/2)

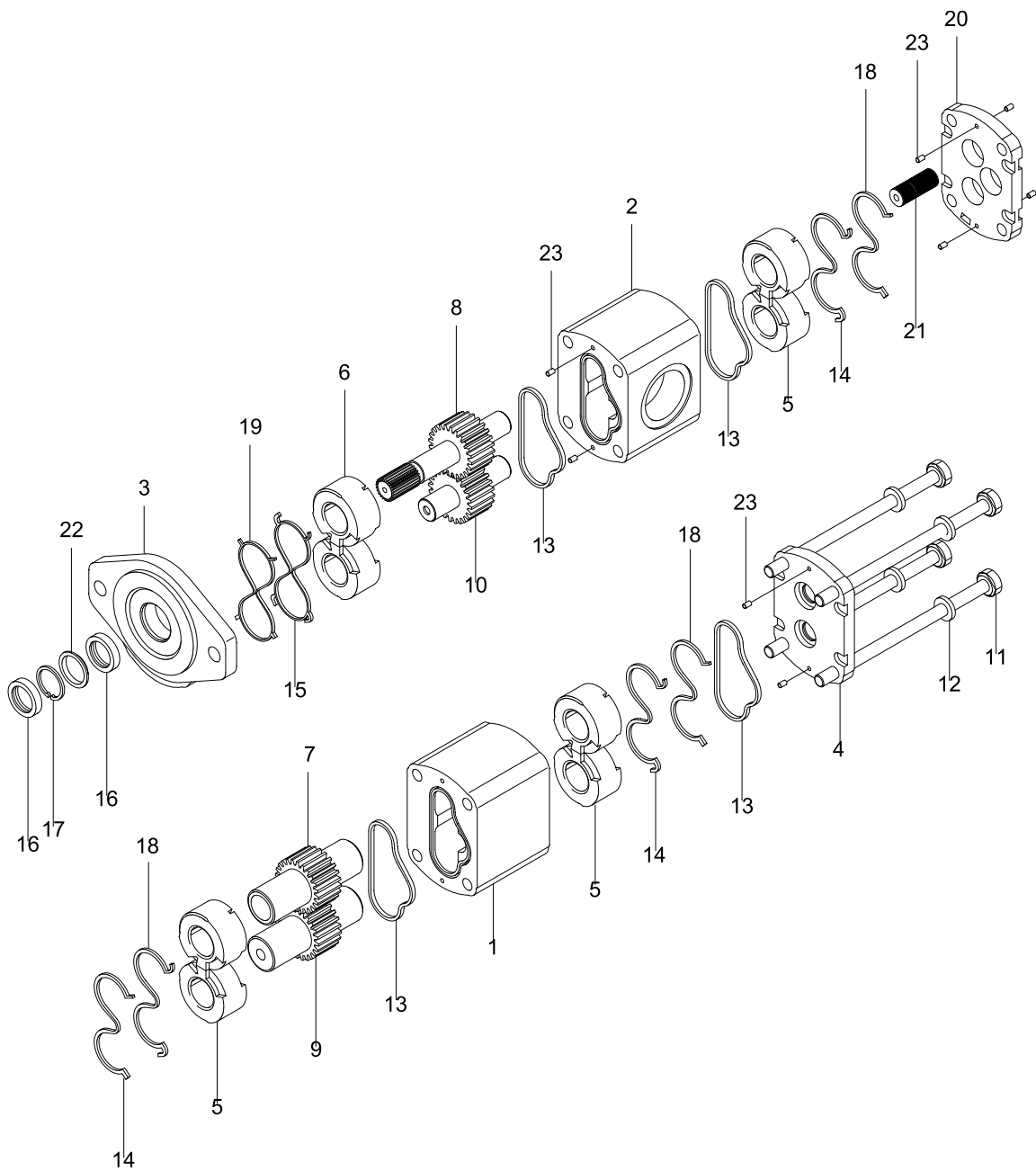

48092GP01

- |   |              |    |             |    |                          |
|---|--------------|----|-------------|----|--------------------------|
| 1 | Body 1       | 9  | Driven gear | 17 | Ring                     |
| 2 | Body 2       | 10 | Driven gear | 18 | Antiextrusion            |
| 3 | Front cover  | 11 | Screw       | 19 | Antiextrusion            |
| 4 | Rear cover   | 12 | Washer      | 20 | Flange                   |
| 5 | Thrust plate | 13 | O-ring      | 21 | Splined connecting shaft |
| 6 | Thrust plate | 14 | Seal        | 23 | Dowel pin                |
| 7 | Drive gear   | 15 | Seal        |    |                          |
| 8 | Drive shaft  | 16 | Shaft seal  |    |                          |

## 2. FUNCTION

### 1) MAIN PUMP

The pumps may be classified roughly into the rotary group performing a rotary motion and working as the major part of the whole pump function: the swash plate group that varies the delivery rates: and the valve cover group that changes over oil suction and discharge.

#### (1) Rotary group

The rotary group consists of drive shaft (F)(111), cylinder block (012), piston shoes (151,152), set plate (153), spherical shoes (151,152), set plate (153), spherical bush (156), and cylinder spring (157).

The drive shaft is supported by bearing (123,124) at its both ends.

The shoe is caulked to the piston to form a spherical coupling. It has a pocket to relieve thrust force generated by loading pressure and to take hydraulic balance so that it slides lightly over the shoe plate (211). The sub group composed by a piston and a shoe is pressed against the shoe plate by the action of the cylinder spring via a retainer and a spherical bush. Similarly, the cylinder block is pressed against valve plate (313) by the action of the cylinder spring.

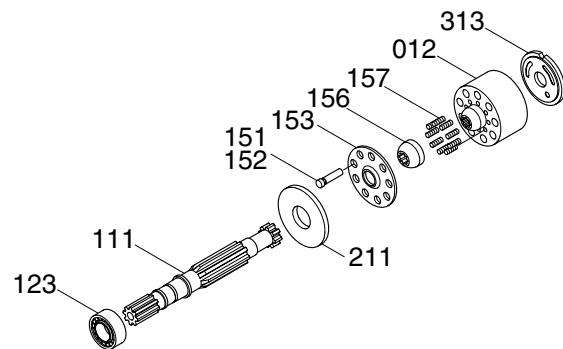

50072MP01

#### (2) Swash plate group

The swash plate group consists of swash plate (212), shoe plate (211), swash plate support (251), tilting bush (214), tilting pin (531) and servo piston (532).

The swash plate is a cylindrical part formed on the opposite side of the sliding surface of the shoe and is supported by the swash support.

If the servo piston moves to the right and left as hydraulic force controlled by the regulator is admitted to hydraulic chamber located on both sides of the servo piston, the swash plate slides over the swash plate support via the spherical part of the tilting pin to change the tilting angle ( $\alpha$ )

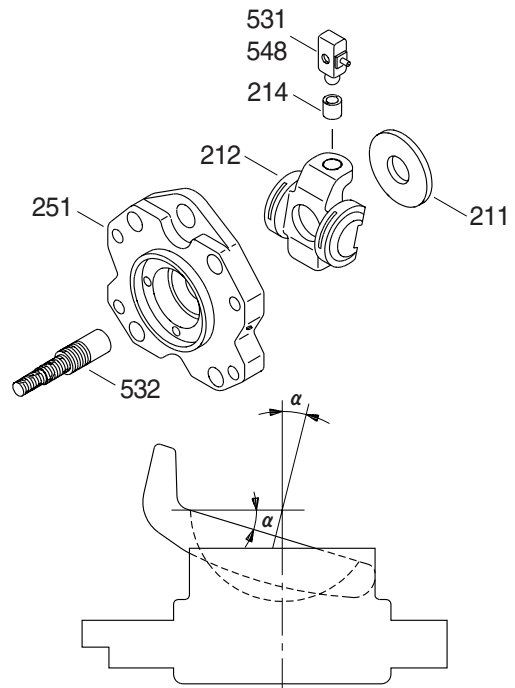

2-7 (210-7)

### (3) Valve block group

The valve cover group consists of valve cover (F, 311), valve cover (R, 312), valve plate (313, 314), spline coupling (114), booster (130) and valve plate pin (885).

The valve plate having two melon-shaped ports is fixed to the valve cover and feeds and collects oil to and from the cylinder cover.

The oil changed over by the valve plate is connected to an external pipeline by way of the valve cover.

Now, if the drive shaft is driven by a prime mover (electric motor, engine, etc), it rotates the cylinder block via a spline linkage at the same time. If the swash plate is tilted as in Fig (previous page) the pistons arranged in the cylinder block make a reciprocating motion with respect to the cylinder block, while they revolve with the cylinder block.

If you pay attention to a single piston, it performs a motion away from the valve plate (oil sucking process) within 180 degrees, and makes a motion towards the valve plate (or oil discharging process) in the rest of 180 degrees. When the swash plate has a tilting angle of zero, the piston makes no stroke and discharges no oil.

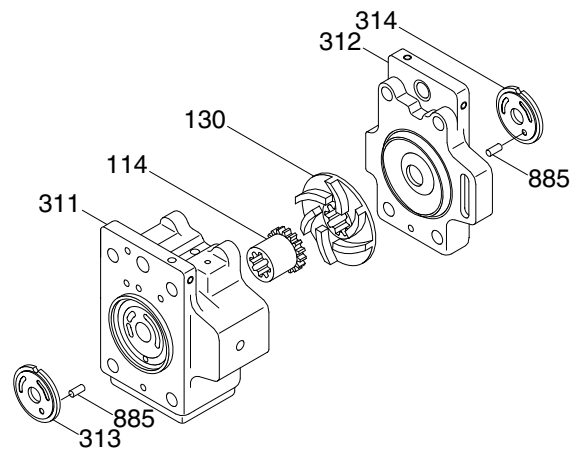

36072MP03

## 2) REGULATOR

Regulator consists of the negative flow control, total horse power control and power shift control function

### (1) Negative flow control

By changing the pilot pressure  $P_i$ , the pump tilting angle (delivery flow) is regulated arbitrarily, as shown in the figure.

This regulator is of the negative flow control in which the delivery flow  $Q$  decreases as the pilot pressure  $P_i$  rises.

With this mechanism, when the pilot pressure corresponding to the flow required for the work is commanded, the pump discharges the required flow only, and so it does not consume the power uselessly.

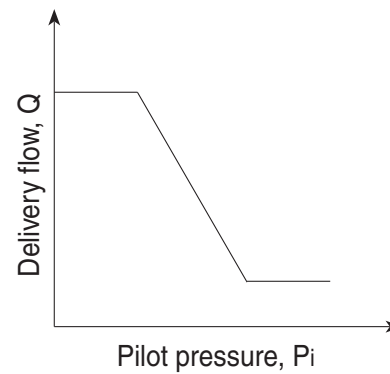

## ① Flow reducing function

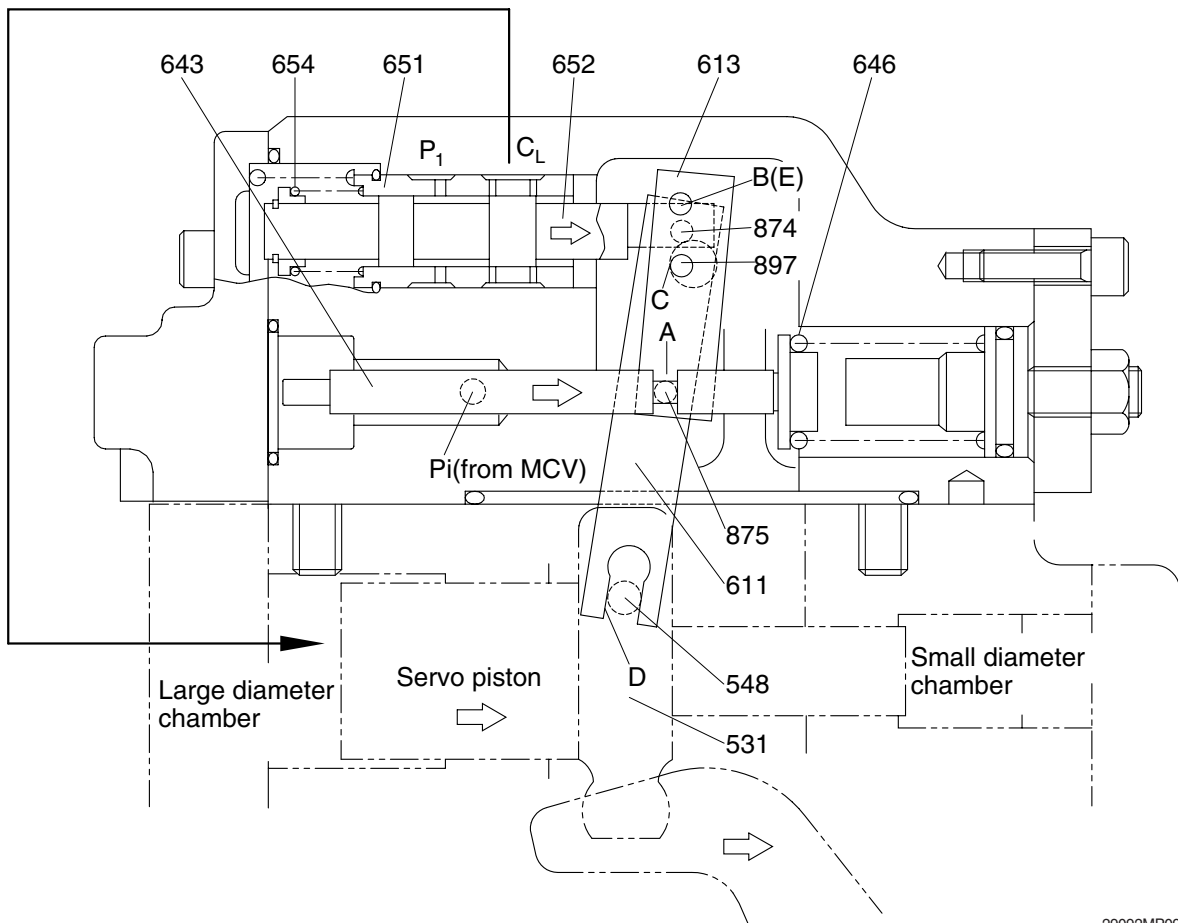

29092MP09A

As the pilot pressure  $P_i$  rises, the pilot piston (643) moves to the right to a position where the force of the pilot spring (646) balances with the hydraulic force.

The groove (A) in the pilot piston is fitted with the pin (875) that is fixed to lever 2 (613). Therefore, when the pilot piston moves, lever 2 rotates around the fulcrum of point B [Fixed by the fulcrum plug (614) and pin (875)]. Since the large hole section (C) of lever 2 contains a protruding pin (897) fixed to the feedback lever (611), the pin (897) moves to the right as lever 2 rotates. Since the opposing-flat section (D) of the feedback lever is fitted with the pin (548) fixed by the tilting pin (531) that swings the swash plate, the feedback lever rotates around the fulcrum of point D, as the pin (897) moves.

Since the feedback lever is connected with the spool (652) via the pin (874), the spool moves to the right.

The movement of the spool causes the delivery pressure  $P_1$  to connect to port CL through the spool and to be admitted to the large diameter section of the servo piston. The delivery pressure  $P_1$  that is constantly admitted to the small diameter section of the servo piston moves the servo piston to the right due to the area difference, resulting in decrease of the tilting angle.

When the servo piston moves to the right, point D also moves to the right. The spool is fitted with the return spring (654) and is tensioned to the left at all times, and so the pin (897) is pressed against the large hole section (C) of lever 2.

Therefore, as point D moves, the feedback lever rotates around the fulcrum of point C, and the spool is shifted to the left. This causes the opening between the sleeve (651) and spool (652) to close slowly, and the servo piston comes to a complete stop when it closes completely.

② Flow increasing function

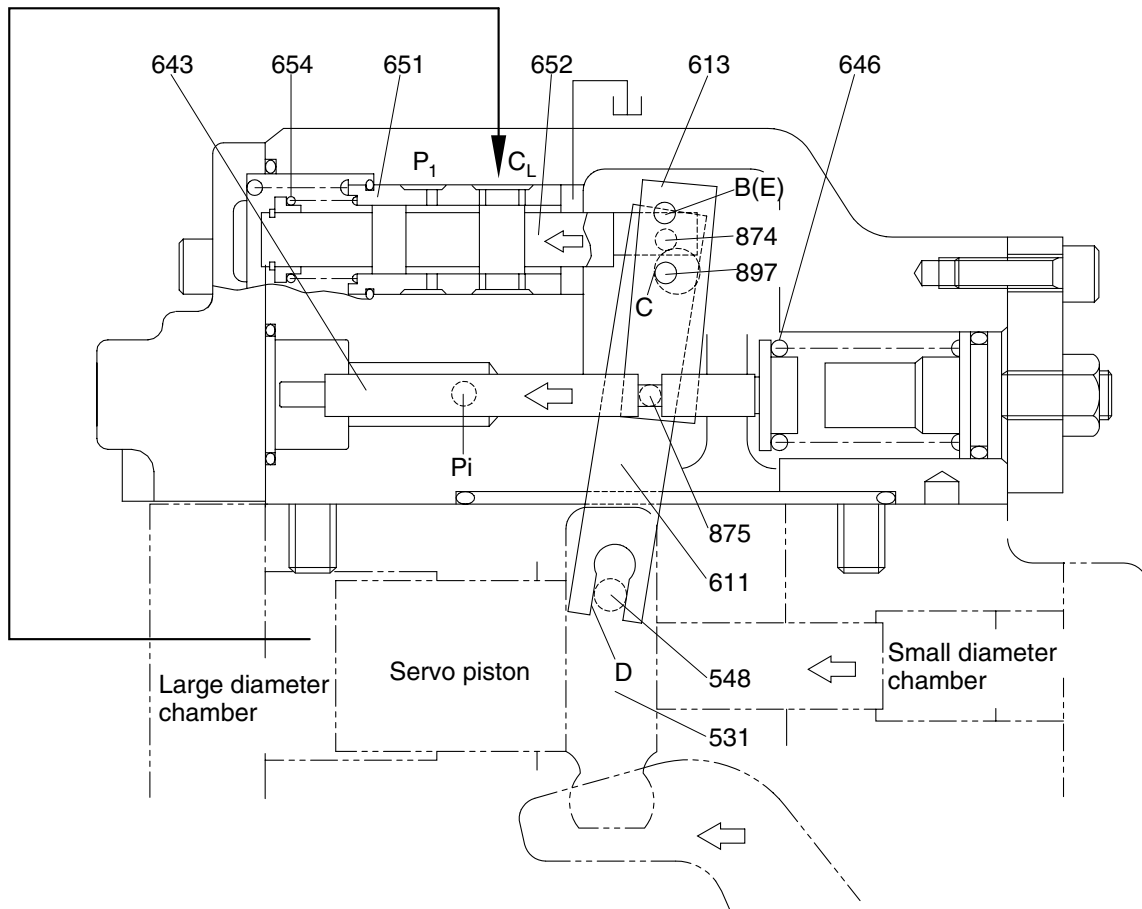

29092MP10

As the pilot pressure  $P_i$  decreases, the pilot piston (643) moves to the left by the action of the pilot spring (646) and causes lever 2 (613) to rotate around the fulcrum of point B. Since the pin (897) is pressed against the large hole section (C) of lever 2 by the action of the return spring (654) via the spool (652), pin (874), and feedback lever (611), the feedback lever rotates around the fulcrum of point D as lever 2 rotates, and shifts the spool to the left. Port CL opens a way to the tank port as the spool moves. This deprives the large diameter section of the servo piston of pressure, and shifts the servo piston to the left by the discharge pressure  $P_1$  in the small diameter section, resulting in an increase in the flow rate.

As the servo piston moves, point D also moves to the left, the feedback lever rotates around the fulcrum of point C, and the spool moves to the right till the opening between the spool and sleeve is closed.

### ③ Adjustment of flow control characteristic

The flow control characteristic can be adjusted with the adjusting screw.

Adjust it by loosening the hexagon nut (801) and by tightening (or loosening) the hexagonal socket head screw (924).

Tightening the screw shifts the control chart to the right as shown in the figure.

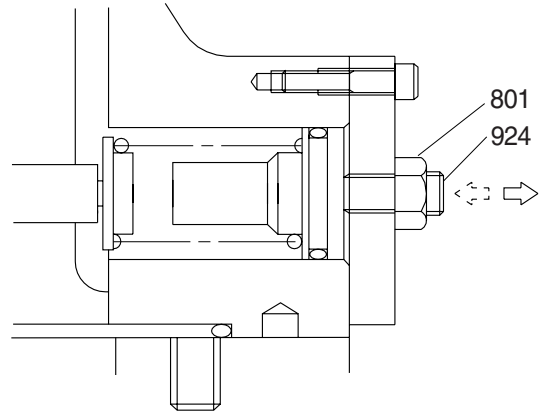

2-12 (210-7)

※ Adjusting values are shown in table.

Speed (min <sup>-1</sup> )	Adjustment of flow control characteristic		
	Tightening amount of adjusting screw (924) (Turn)	Flow control starting pressure change amount (kgf/cm <sup>2</sup> )	Flow change amount ( l /min)
1800	+1/4	+1.63	+21

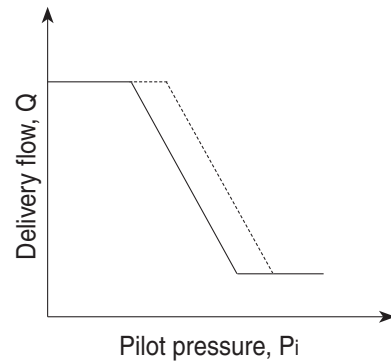

## (2) Total horsepower control

The regulator decreases the pump tilting angle (delivery flow) automatically to limit the input torque within a certain value with a rise in the delivery pressure P1 of the self pump and the delivery pressure P2 of the companion pump.

(The input horsepower is constant when the speed is constant.)

Since the regulator is of the simultaneous total horsepower type that operates by the sum of load pressures of the two pumps in the tandem double-pump system, the prime mover is automatically prevented from being overloaded, irrespective of the load condition of the two pumps, when horsepower control is under way.

Since this regulator is of the simultaneous total horsepower type, it controls the tilting angles (displacement volumes) of the two pumps to the same value as represented by the following equation :

$$\begin{aligned} T_{in} &= P1 \times q / 2 \pi + P2 \times q / 2 \pi \\ &= (P1+P2) \times q / 2 \pi \end{aligned}$$

The horsepower control function is the same as the flow control function and is summarized in the following. (For detailed behaviors of respective parts, refer to the section of flow control).

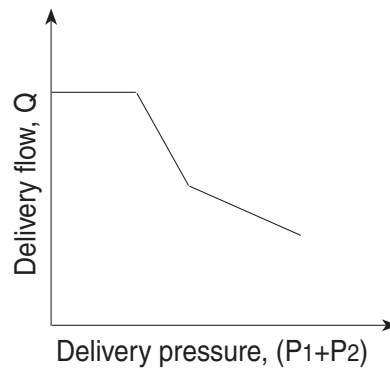

## ① Overload preventive function

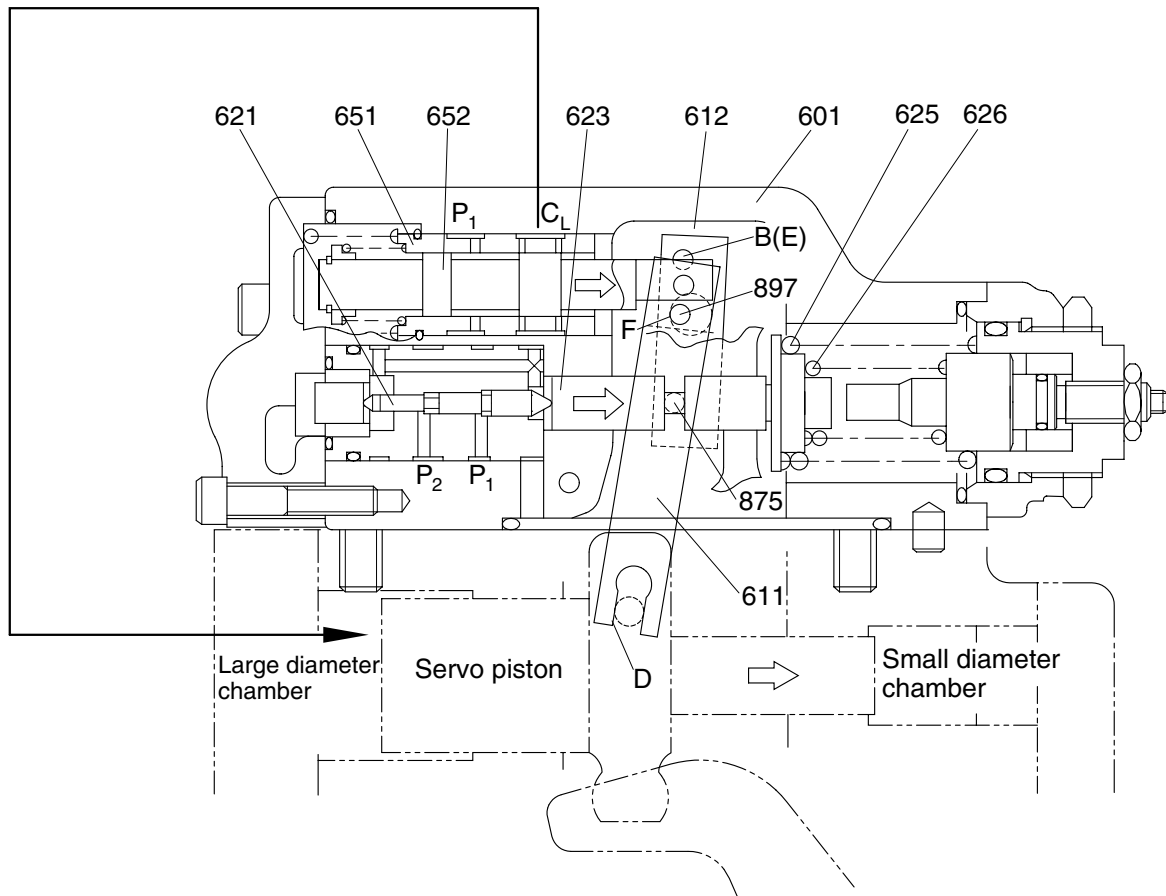

29092MP11

When the self pump delivery pressure  $P_1$  or the companion pump delivery pressure  $P_2$  rises, it acts on the stepped part of the compensating piston (621). It presses the compensating rod (623) to the right till the force of the outer spring (625) and inner spring (626) balances with the hydraulic force. The movement of the compensating rod is transmitted to lever 1 (612) via pin (875).

Lever 1 rotates around the pin (875) (E) fixed to the casing (601).

Since the large hole section (F) of lever 1 contains a protruding pin (897) fixed to the feedback lever (611), the feedback lever rotates around the fulcrum of point D as lever 1 rotates, and then the spool (652) is shifted to the right. As the spool moves, the delivery pressure  $P_1$  is admitted to the large diameter section of the servo piston via port CL, causes the servo piston move to the right, reduces the pump delivery, flow rate, and prevents the prime mover from being overloaded. The movement of the servo piston is transmitted to the feedback lever via point D. Then the feedback lever rotates around the fulcrum of point F and the spool is shifted to the left. The spool moves till the opening between the spool (652) and sleeve (651) is closed.

② Flow reset function

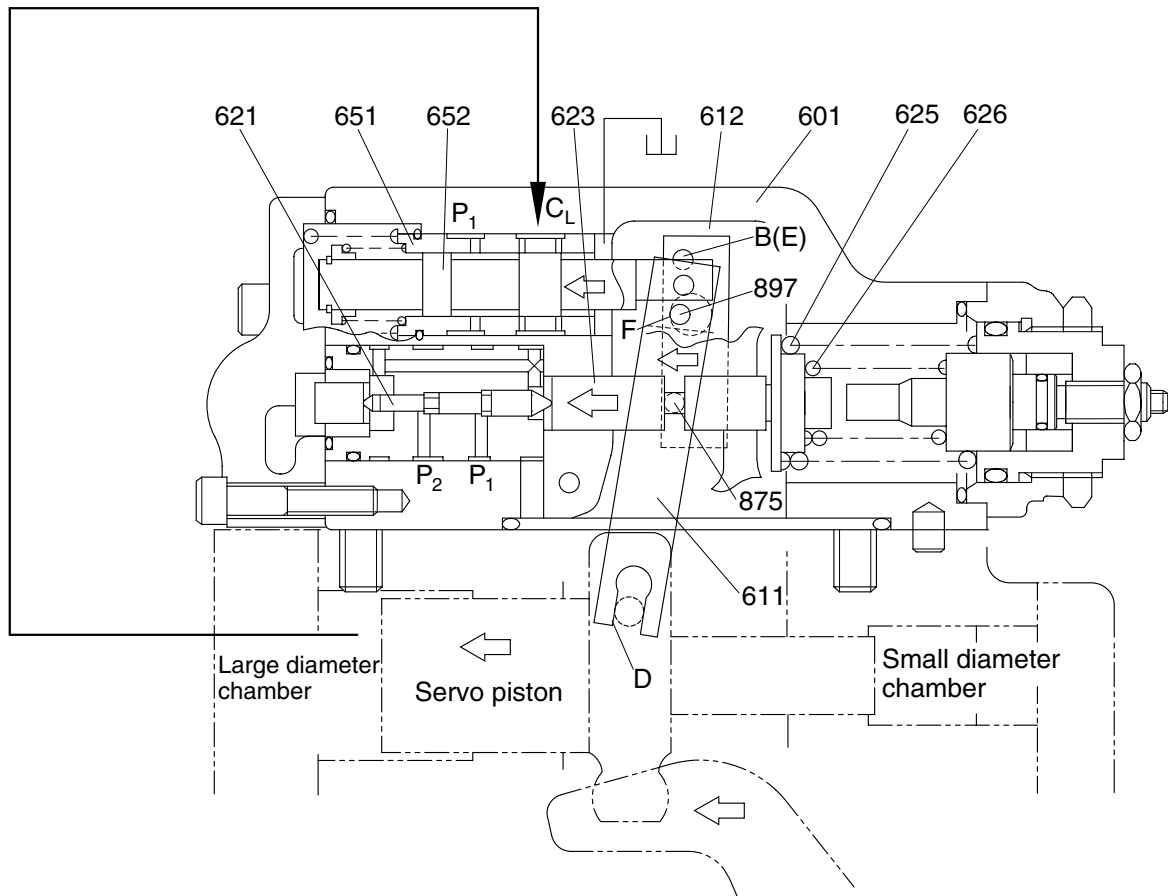

29092MP12

As the self pump delivery pressure  $P_1$  or the companion pump delivery pressure  $P_2$  decreases, the compensating rod (623) is pushed back by the action of the springs (625 & 626) to rotate lever 1 (612) around point E. Rotating of lever 1 causes the feedback lever (611) to rotate around the fulcrum of point D and then the spool (652) to move to the left. As a result, port CL opens a way to the tank port.

This causes the servo piston to move to the left and the pump's delivery rate to increase.

The movement of the servo piston is transmitted to the spool by the action of the feedback mechanism to move it till the opening between the spool and sleeve is closed.

③ **Low tilting angle (low flow) command preferential function**

As mentioned above, flow control and horsepower control tilting angle commands are transmitted to the feedback lever and spool via the large-hole sections (C & F) of levers 1 and 2. However, since sections C and F have the pins ( $\varnothing 4$ ) protruding from the large hole ( $\varnothing 8$ ), only the lever lessening the tilting angle contacts the pin (897); the hole ( $\varnothing 8$ ) in the lever of a larger tilting angle command is freed without contacting the pin (897). Such a mechanical selection method permits preference of the lower tilting angle command of the flow control and horsepower control.

④ **Adjustment of input horsepower**

Since the regulator is of total cumulative horsepower type, adjust the adjusting screws of both the front and rear pumps, when changing the horsepower set values. The pressure change values by adjustment are based on two pumps pressurized at the same time, and the values will be doubled when only one pump is loaded.

a. **Adjustment of outer spring**

Adjust it by loosening the hexagon nut (630) and by tightening (or loosening) the adjusting screw C (628). Tightening the screw shifts the control chart to the right and increases the input horsepower as shown in the figure. Since turning the adjusting screw C by N turns changes the setting of the inner spring (626), return the adjusting screw QI (627) by  $N \times A$  turns at first. ( $A=1.85$ )

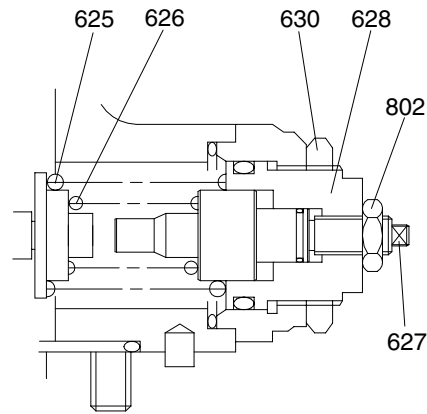

※ **Adjusting values are shown in table.**

Speed	Adjustment of outer spring		
	Tightening amount of adjusting screw (C) (627)	Compensating control starting pressure change amount	Input torque change amount
(min <sup>-1</sup> )	(Turn)	(kgf/cm <sup>2</sup> )	(kgf · m)
1800	+1/4	+17.7	+9.6

8007A2MP03

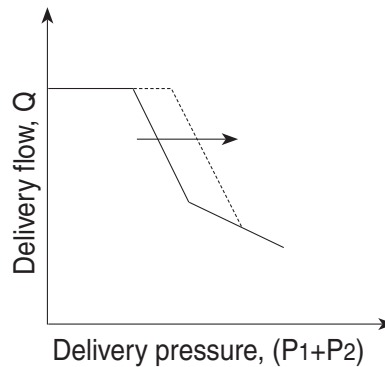

**b. Adjustment of inner spring**

Adjust it by loosening the hexagon nut (802) and by tightening (or loosening) the adjusting screw QI (627).

Tightening the screw increases the flow and then the input horsepower as shown in the figure.

※ Adjusting valves are shown in table.

Speed	Adjustment of inner spring		
	Tightening amount of adjusting screw (QI) (627)	Flow change amount (lpm)	Input torque change amount
(min <sup>-1</sup> )	(Turn)	( l /min)	(kgf · m)
1800	+1/4	+18.6	+10.3

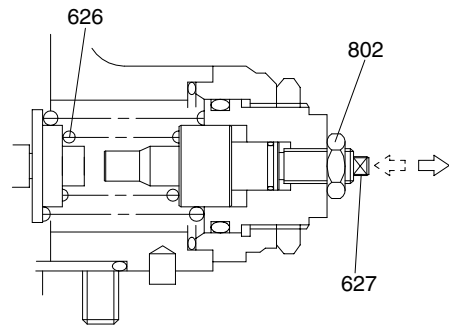

8007A2MP04

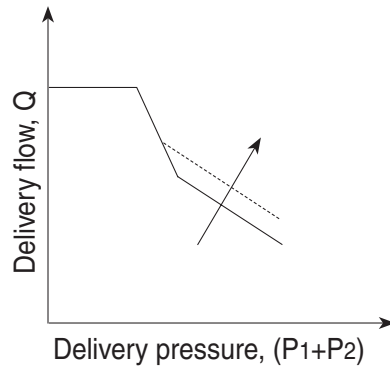

### (3) Power shift control

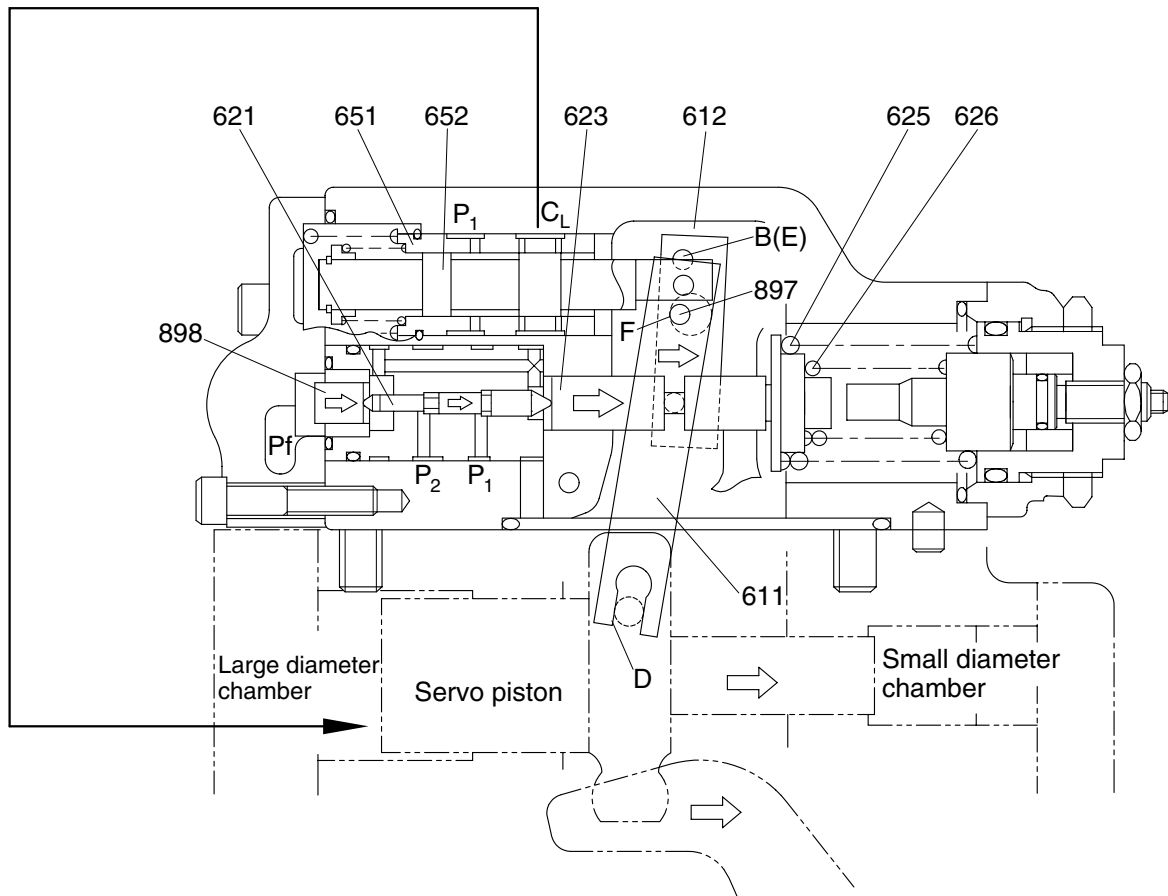

29092MP13

The set horsepower valve is shifted by varying the command current level of the proportional pressure reducing valve attached to the pump.

Only one proportional pressure reducing valve is provided. However, the secondary pressure  $P_f$  (power shift pressure) is admitted to the horsepower control section of each pump regulator through the pump's internal path to shift it to the same set horsepower level.

This function permits arbitrary setting of the pump output power, thereby providing the optimum power level according to the operating condition.

The power shift pressure  $P_f$  controls the set horsepower of the pump to a desired level, as shown in the figure.

As the power shift pressure  $P_f$  rises, the compensating rod (623) moves to the right via the pin (898) and compensating piston (621).

This decreases the pump tilting angle and then the set horsepower in the same way as explained in the overload preventive function of the horsepower control. On the contrary, the set horsepower rises as the power shift pressure  $P_f$  falls.

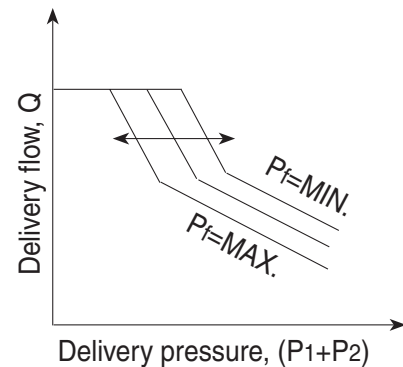

#### (4) Adjustment of maximum and minimum flows

##### ① Adjustment of maximum flow

Adjust it by loosening the hexagon nut (808) and by tightening (or loosening) the set screw (954).

The maximum flow only is adjusted without changing other control characteristics.

Speed	Adjustment of max flow spring	
	Tightening amount of adjusting screw (954)	Flow change amount
(min <sup>-1</sup> )	(Turn)	( l /min)
1800	+1/4	-6.9

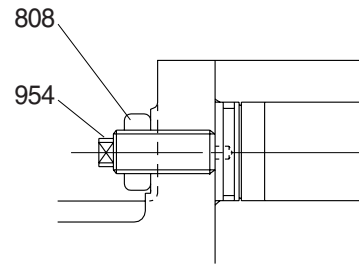

2-19 (1)

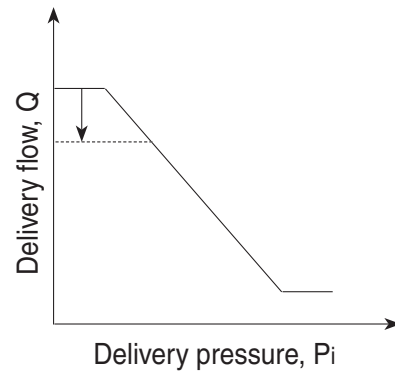

##### ② Adjustment of minimum flow

Adjust it by loosening the hexagon nut (808) and by tightening (or loosening) the hexagonal socket head set screw (953). Similarly to the adjustment of the maximum flow, other characteristics are not changed.

However, remember that, if tightened too much, the required horsepower during the maximum delivery pressure (or during relieving) may increase.

Speed	Adjustment of min flow spring	
	Tightening amount of adjusting screw (953)	Flow change amount
(min <sup>-1</sup> )	(Turn)	( l /min)
1800	+1/4	+6.9

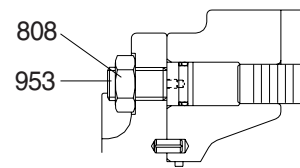

2-19 (2)

