

GROUP 4 HYDRAULIC SYSTEM

HYDRAULIC COMPONENTS MOUNTING 1

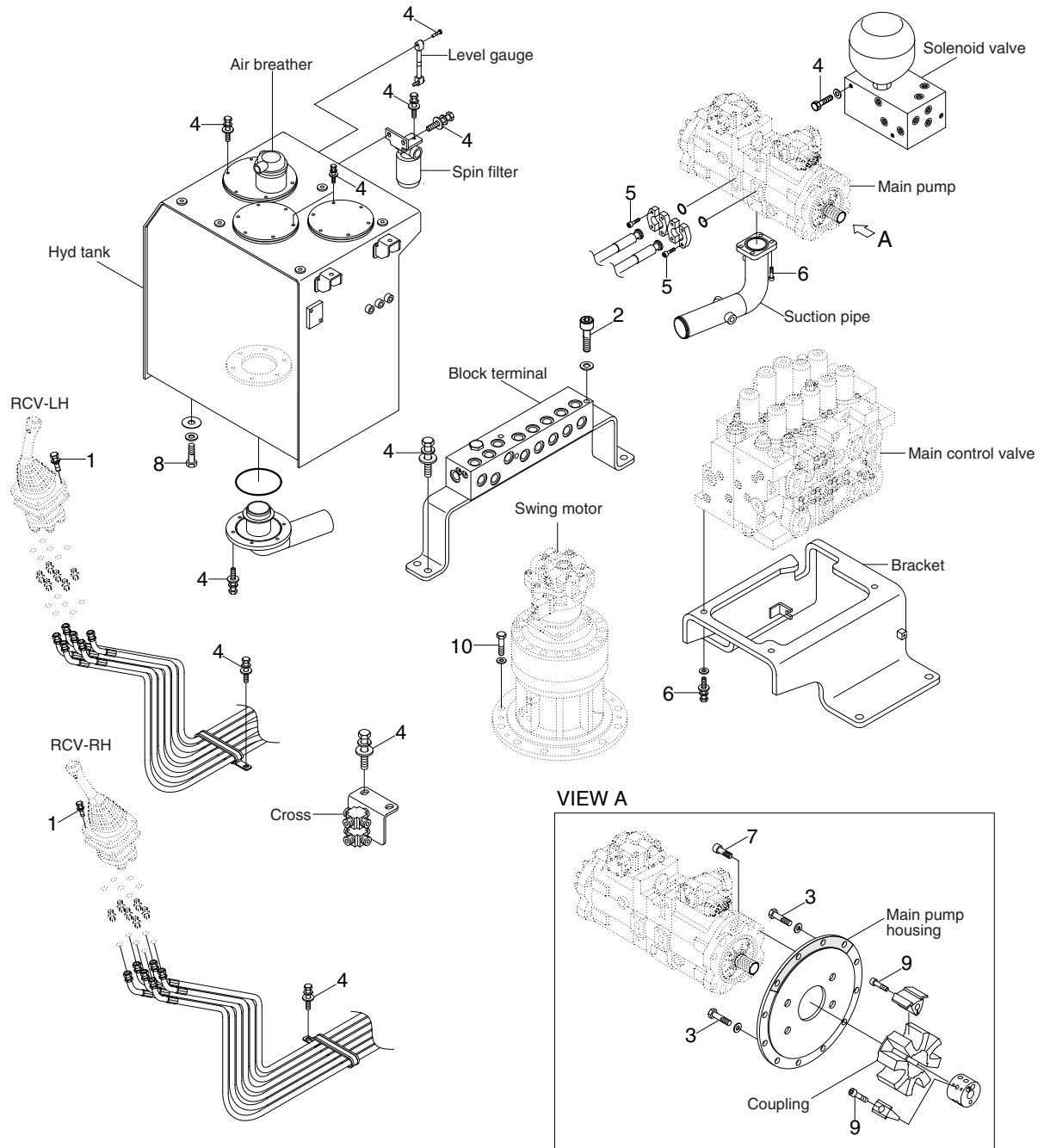

38099CM05

· Tightening torque

Item	Size	kgf · m	lbf · ft
1	M 6×1.0	1.05±0.2	7.6±1.45
2	M 8×1.25	2.5±0.5	18.1±3.6
3	M10×1.5	5.3±0.5	38.3±3.6
4	M10×1.5	6.9±1.4	49.9±10.1
5	M12×1.75	12.3±1.3	92.5±21.6

Item	Size	kgf · m	lbf · ft
6	M16×2.0	29.7±4.5	215±32.5
7	M20×2.5	42±4.5	304±32.5
8	M20×2.5	46±5.1	333±36.9
9	M20×2.5	46.5±2.5	336±18.1
10	M24×3.0	97.8±15	707±108

HYDRAULIC COMPONENTS MOUNTING 2

Double acting attachment piping

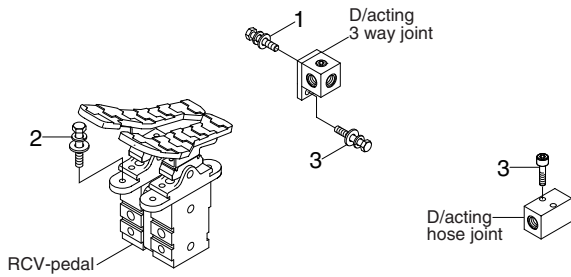
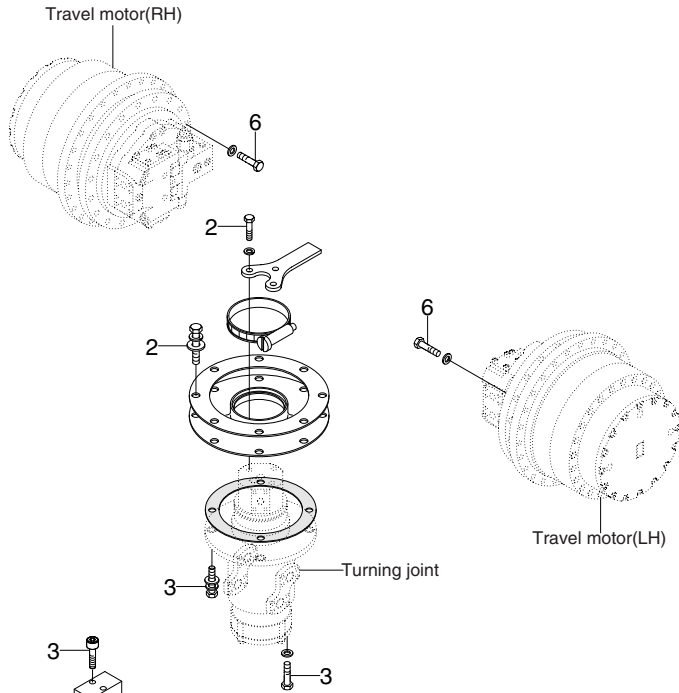
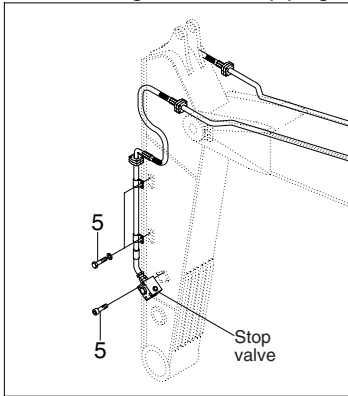

Arm safety lock system

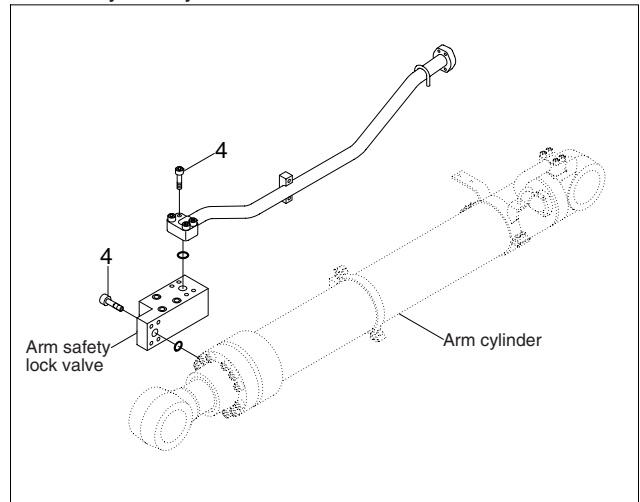

D/acting single pedal

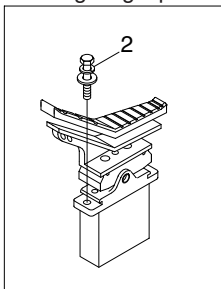

Boom safety lock system

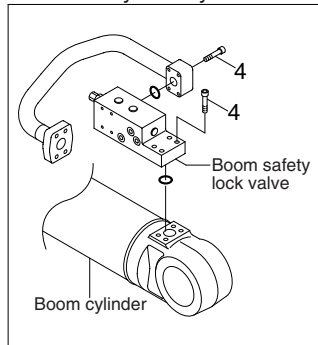

38099CM06

· Tightening torque

Item	Size	kgf · m	lbf · ft
1	M 8 × 1.25	4.05 ± 0.8	29.3 ± 5.8
2	M 10 × 1.5	6.9 ± 1.4	49.9 ± 10.1
3	M 12 × 1.75	12.3 ± 1.3	88.9 ± 9.4

Item	Size	kgf · m	lbf · ft
4	M 12 × 1.75	12.8 ± 3.0	92.6 ± 21.7
5	M 16 × 2.0	29.7 ± 4.5	215 ± 32.5
6	M 20 × 2.5	58 ± 6.0	420 ± 43.4

HYDRAULIC COMPONENTS MOUNTING 3

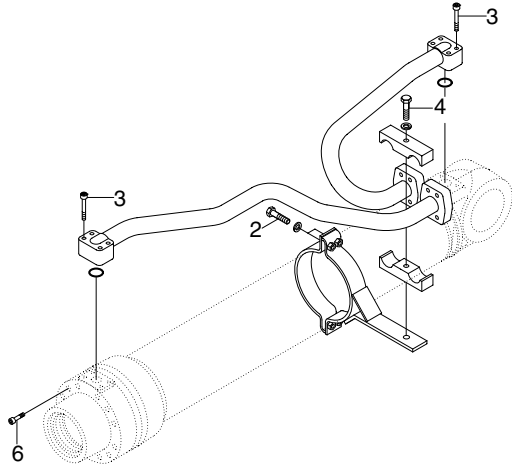

BOOM CYLINDER

Solenoid valve

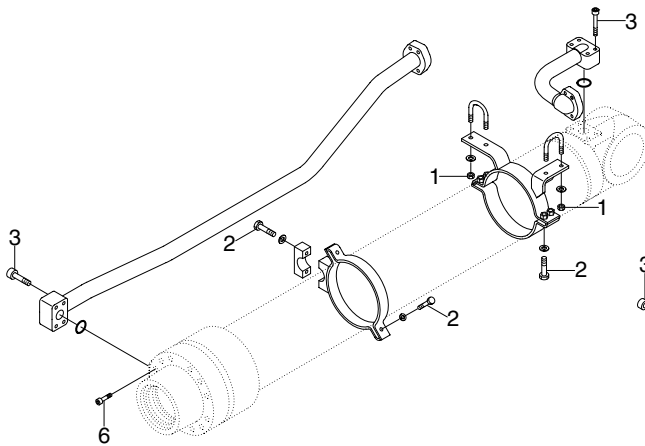
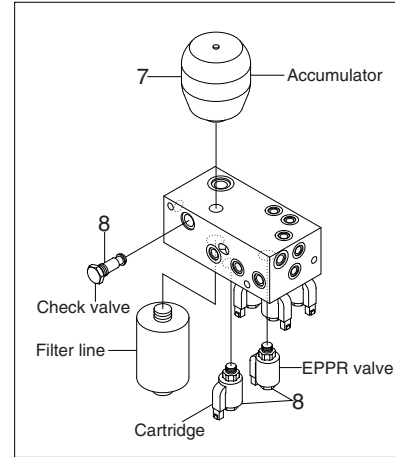

ARM CYLINDER

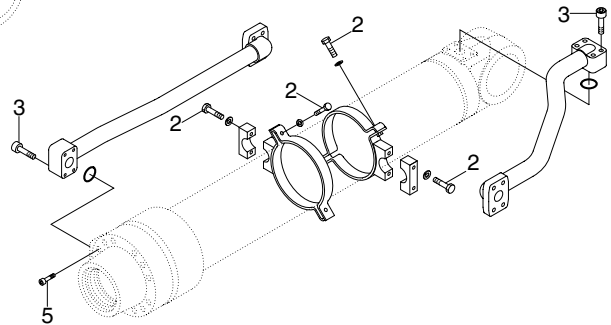

BUCKET CYLINDER

38099CM07

· Tightening torque

Item	Size	kgf · m	lbf · ft
1	M10×1.5	3.2±0.3	23.1±2.2
2	M12×1.75	5.5±0.6	39.8±4.3
3	M12×1.75	9.4±1.0	68.0±7.2
4	M16×2.0	14±1.4	101±10.1

Item	Size	kgf · m	lbf · ft
5	M20×2.5	46±5.0	333±36.2
6	M22×2.5	63±6.0	456±43.4
7	M22×2.5	4.1	29.6
8	M27×3.0	5.1	36.9