

GROUP 3 SWING DEVICE

1. STRUCTURE

Swing device consists swing motor, swing reduction gear.

Swing motor include mechanical parking valve, relief valve, make up valve and time delay valve.

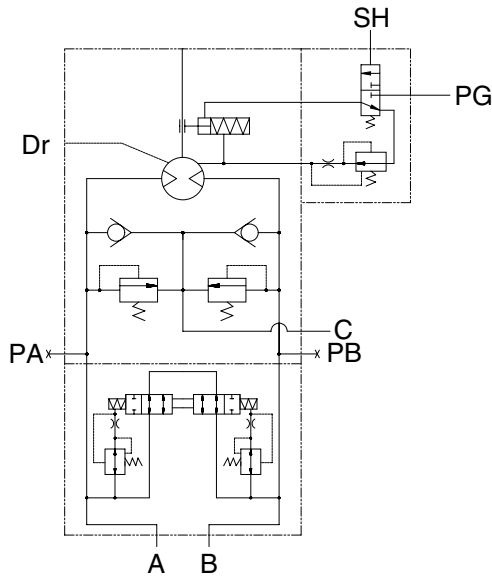
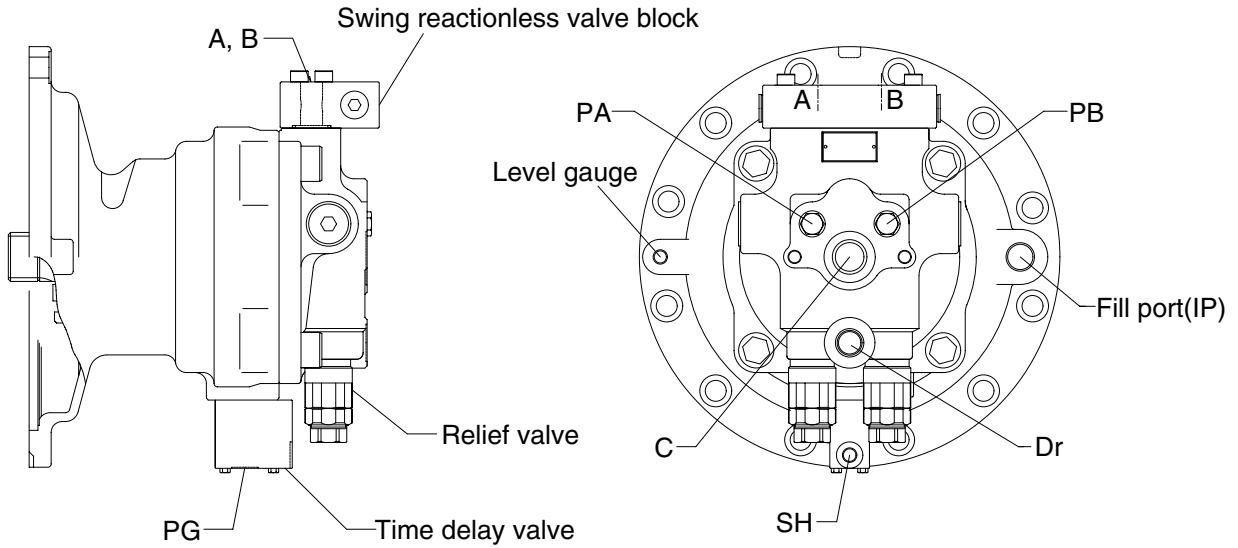

R32072SM04

Port	Port name	Port size
A, B	Main port	SAE 5000psi 3/4"
Dr	Drain port	PF 1/2-19
C	Make up port	PF 1-24
PA, PB	Gauge port	PF 1/4-12
PG	Brake release port	PF 1/4-12
SH	Brake pilot port	PF 1/4-12
IP	Gear oil inlet port	PT 3/4-19

1) SWING MOTOR

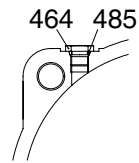
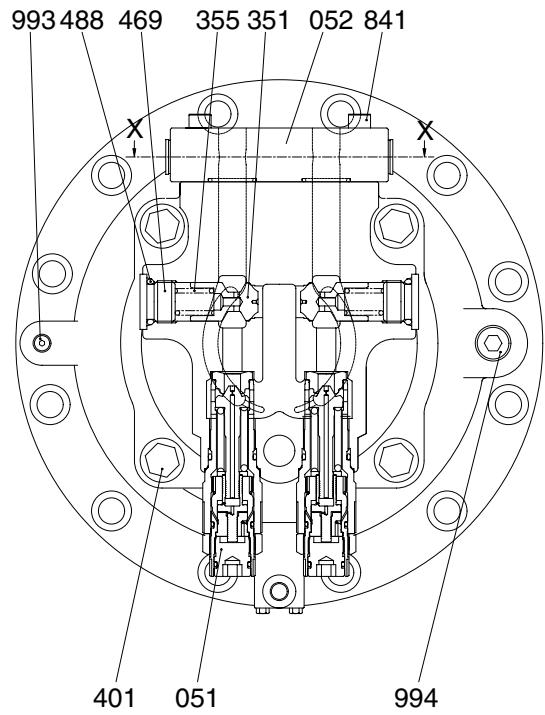
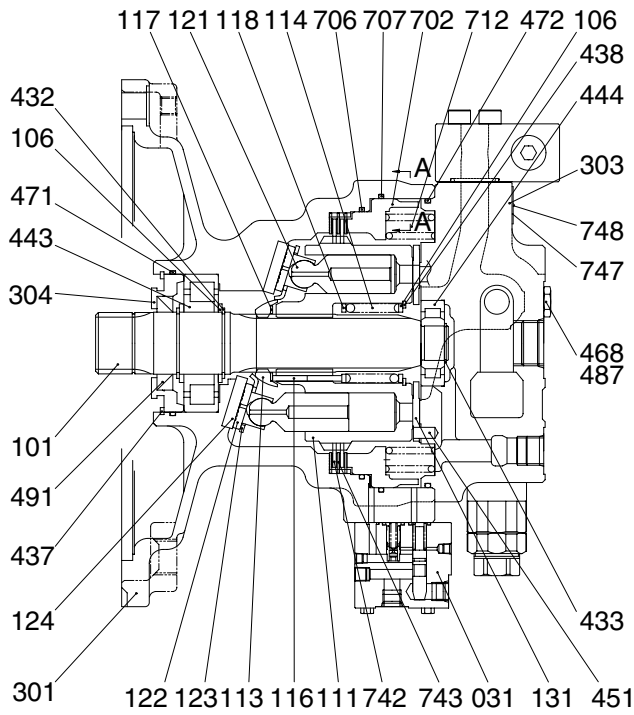

SECTION A - A

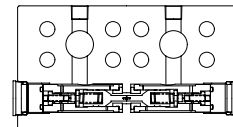

SECTION X-X

R32072SM02

031	Time delay valve	162	O-ring	468	Plug
051	Relief valve	163	O-ring	469	Plug
052	Valve assy	171	Hexagon screw	471	O-ring
101	Drive shaft	301	Casing	472	O-ring
106	Spacer	303	Casing	485	O-ring
111	Cylinder	304	Front cover	487	O-ring
113	Spherical bush	351	Plunger	488	O-ring
114	Spring	355	Spring	491	Oil seal
116	Push rod	401	Socket bolt	702	Piston
117	Spacer	432	Snap ring	706	O-ring
118	Spacer	433	Snap ring	707	O-ring
121	Piston	437	Snap ring	712	Brake spring
122	Shoe	438	Snap ring	742	Friction plate
123	Retainer	443	Roller bearing	743	Separate plate
124	Shoe plate	444	Needle bearing	841	Socket bolt
131	Valve plate	451	Spring pin	993	Level gauge
161	O-ring	464	Plug	994	Air breather

2) REDUCTION GEAR

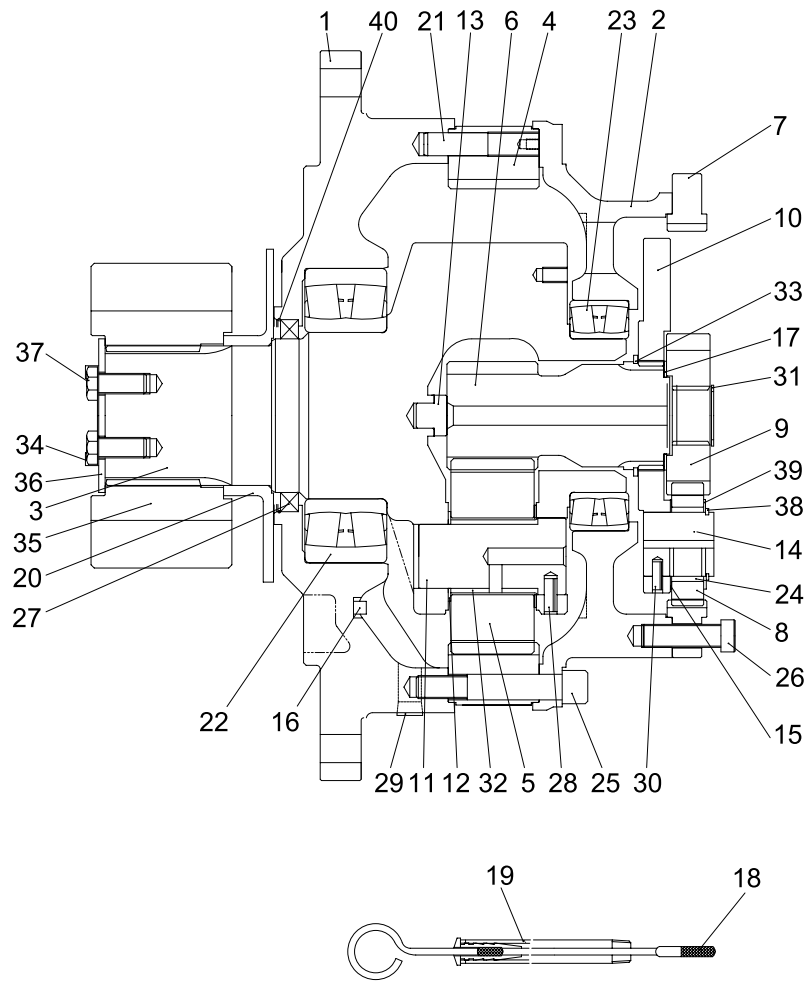

1	Front casing	14	Pin 1	27	Oil seal
2	Middle casing	15	Side plate 1	28	Spring pin
3	Drive shaft	16	Magnet	29	Pressure plug
4	Ring gear 2	17	Side plate 3	30	Spring pin
5	Planet gear 2	18	Gauge bar	31	Stop ring
6	Sun gear 2	19	Gauge pipe	32	Bushing 2
7	Ring gear 1	20	Spacer ring	33	Stop ring
8	Planet gear 1	21	Knock pin	34	Lock washer
9	Sun gear 1	22	Roller bearing	35	Pinion gear
10	Carrier	23	Roller bearing	36	Lock plate
11	Pin 2	24	Needle cage	37	Hexagon bolt
12	Thrust washer	25	Socket bolt	38	Stop ring
13	Thrust button	26	Socket bolt	39	Side plate 2
				40	Circle clip

R32072RG01

2. FUNCTION

1) ROTARY PART

When high pressurized oil enters a cylinder through port(a), which is the inlet of balance plate(131), hydraulic pressure acting on the piston causes axial force F. The pressure force F works via the piston(121) upon the return plate(123) which acts upon the swash plate(124) via an hydrostatic bearing. Force F1 perpendicular to swash plate(124) and force F2 perpendicular to cylinder center. Being transferred to the cylinder block(111) through piston, force F2 causes rotational moment at surroundings of cylinder.

Since cylinder block has 9 equidistantly arrayed pistons, rotational torque is transmitted to cylinder shaft in order by several pistons connected to the inlet port of high pressurized oil. When the direction of oil flow is reversed, rotational direction of cylinder is also reversed. Output torque is given by the equation.

$$T = \frac{p \times q}{2}, q = Z \cdot A \cdot \text{PCD} \cdot \tan \theta, F_1 = \frac{F}{\cos \theta}, F_2 = F \tan \theta, S = \text{PCD} \times \tan \theta$$

Where p : Effective difference of pressure(kgf/cm²)

q : Displacement(cc/rev)

T : Output torque(kgf · cm)

Z : Piston number(9EA)

A : Piston area(cm²)

θ : Tilting angle of swash plate(degree)

S : Piston stroke(cm)

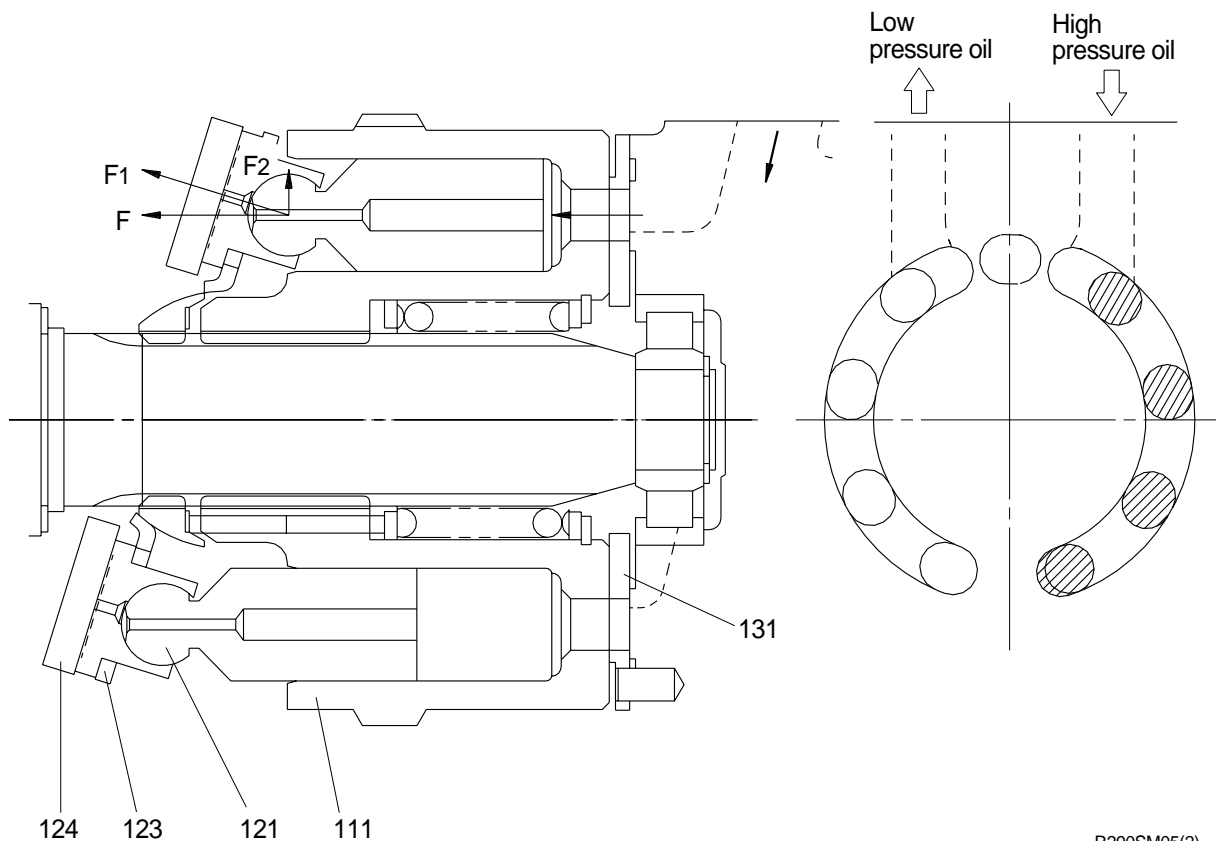

R290SM05(2)

2) MAKE UP VALVE

In the system using this type of motor, there is no counter balance functioning valve and there happens the case of revolution exceeding hydraulic supply of motor. To prevent the cavitation caused by insufficient oil flow there is a make up valve to fill up the oil insufficiency.

A make up valve is provided immediately before the port leading to the hydraulic oil tank to secure feed pressure required when the hydraulic motor makes a pumping action. The boost pressure acts on the hydraulic motor's feed port via the make up valve.

Pressurized oil into the port B, the motor rotate counterclockwise.

If the plunger of MCV moves neutral position, the oil in the motor is drain via left relief valve, the drain oil run into motor via right make up valve, which prevent the cavitation of motor.

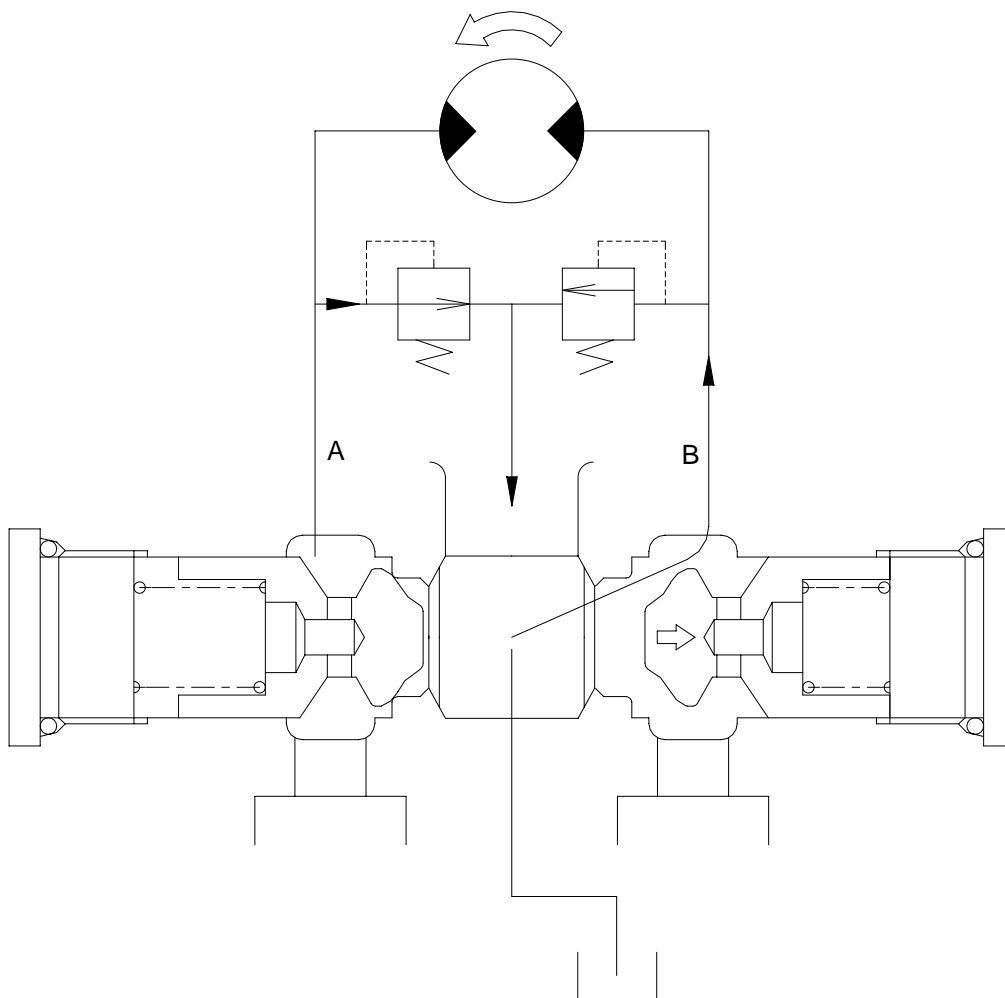

29072SM09

3) RELIEF VALVE

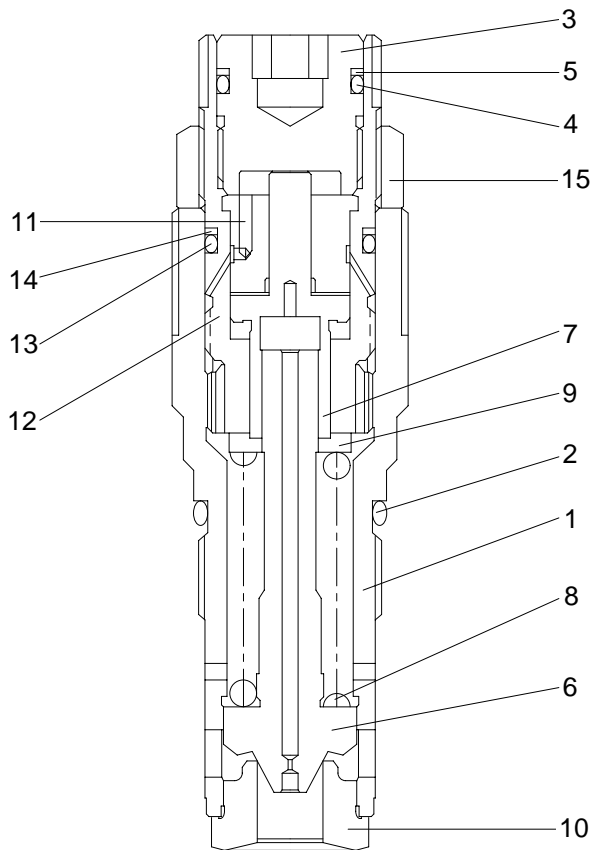

- 1 Body
- 2 O-ring
- 3 Plug
- 4 O-ring
- 5 Back up ring
- 6 Plunger
- 7 Piston
- 8 Spring
- 9 Seat spring
- 10 Seat
- 11 Sleeve
- 12 Adjust plug
- 13 O-ring
- 14 Back up ring
- 15 Nut

29072SM03

(1) Construction of relief valve

The valve casing contains two cartridge type relief valves that stop the regular and reverse rotations of the hydraulic motor. The relief valves relieve high pressure at start or at stop of swing motion and can control the relief pressure in two steps, high and low, in order to insure smooth operation.

(2) Function of relief valve

Figure illustrates how the pressure acting on the relief valve is related to its rising process. Here is given the function, referring to the figure following page.

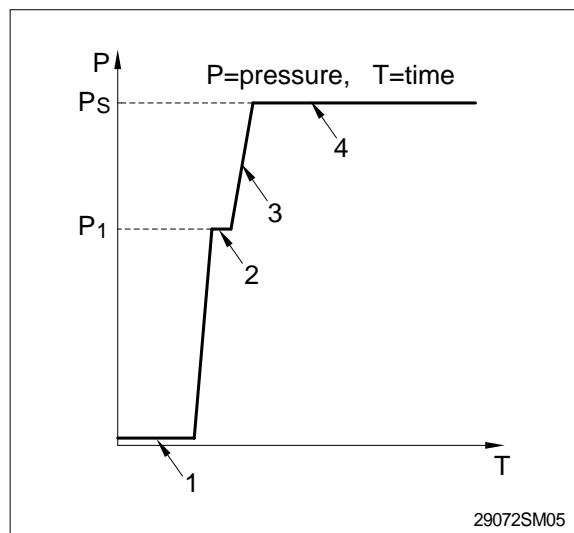

29072SM05

Ports (P,R) at tank pressure.

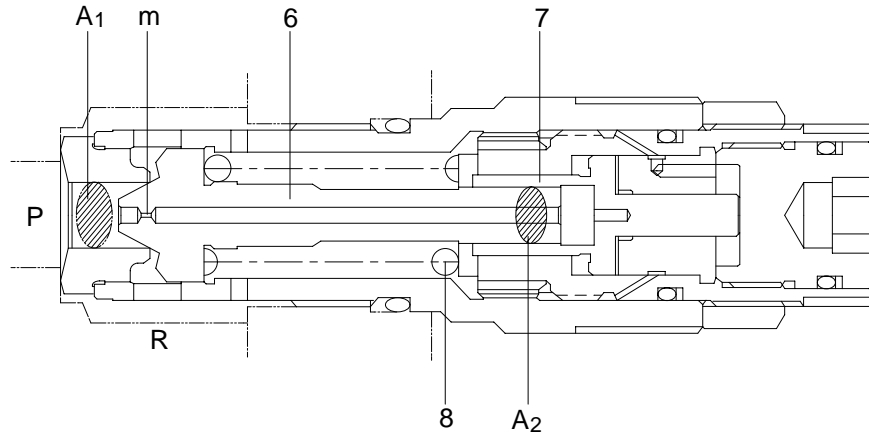

29072SM04

When hydraulic oil pressure ($P \times A_1$) reaches the preset force (F_{SP}) of spring (8), the plunger (6) moves to the right as shown.

$$P_1 \times A_1 = F_{sp} + P_1 \times A_2$$

$$P_1 = \frac{F_{sp}}{A_1 - A_2}$$

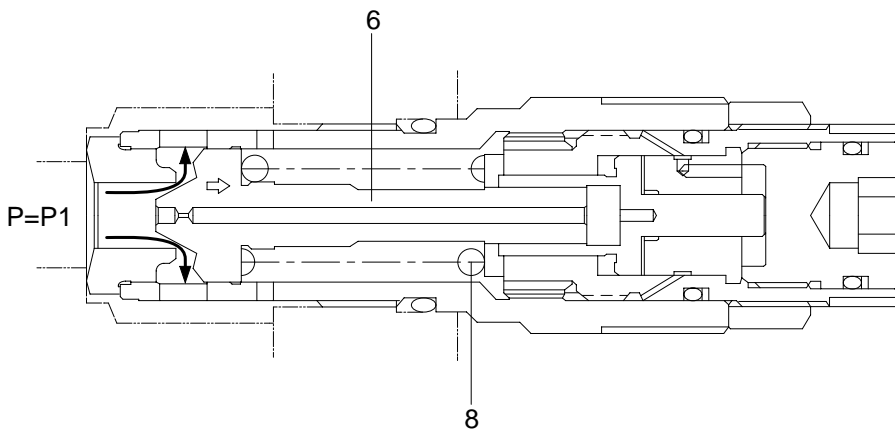

29072SM06

When the pressure of chamber g reaches the preset force(F_{sp}) of spring(8), the piston(7) moves right and stop the piston(7) hits the end of body.

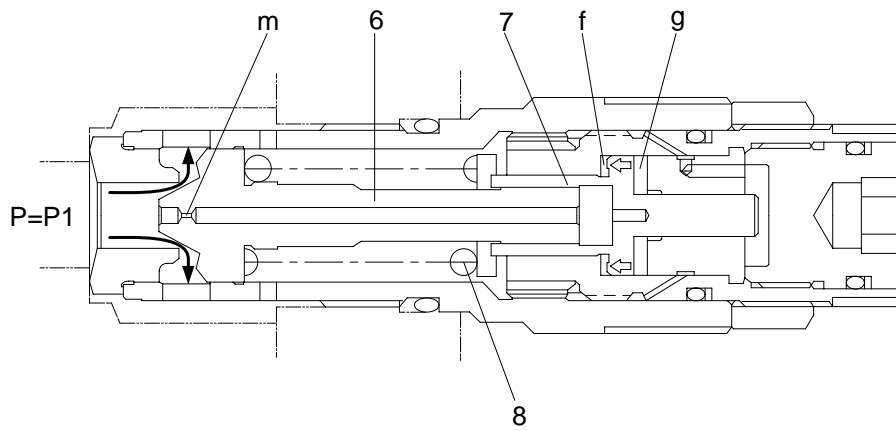

29072SM07

When piston(7) hits the end of body, it stops moving to the right any further. As the result, the pressure in chamber(g) equals(P_s).

$$P_s \times A_1 = F_{sp} + P_s \times A_3$$

$$P_s = \frac{F_{sp}}{A_1 - A_3}$$

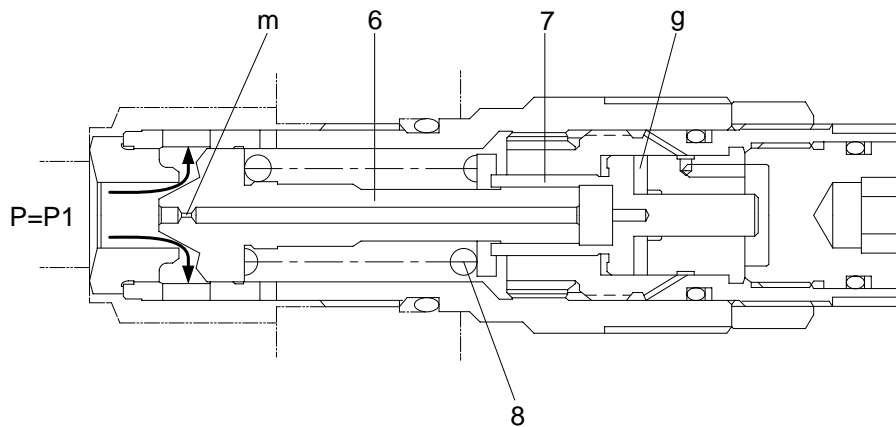

29072SM08

4) BRAKE SYSTEM

(1) Control valve swing brake system

This is the brake system to stop the swing motion of the excavator during operation.

In this system, the hydraulic circuit is throttled by the swing control valve, and the resistance created by this throttling works as a brake force to slow down the swing motion.

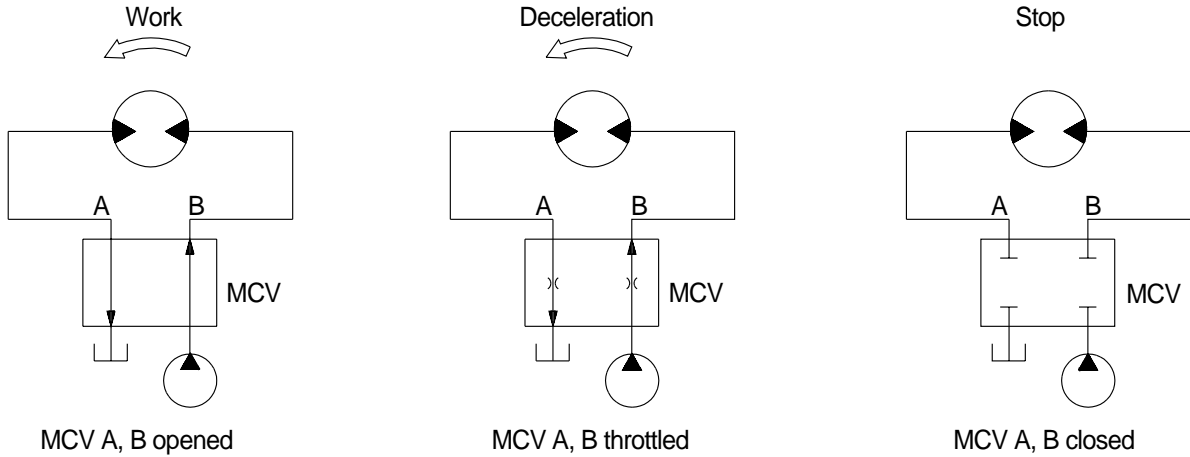

(2) Mechanical swing parking brake system

The mechanical swing parking brake system is installed to prevent the upper structure from swinging downhill because of its own weight when the excavator is parked on a slope since it completely eliminates the hydraulic drift of swing motion while the excavator is on a slope, work can be done more easily and safely.

Brake assembly

Circumferential rotation of separate plate(743) is constrained by the groove located at casing(301). When housing is pressed down by brake spring(712) through friction plate(742), separate plate(743) and brake piston(702), friction force occurs there.

Cylinder(111) is constrained by this friction force and brake acts, while brake releases when hydraulic force exceeds spring force.

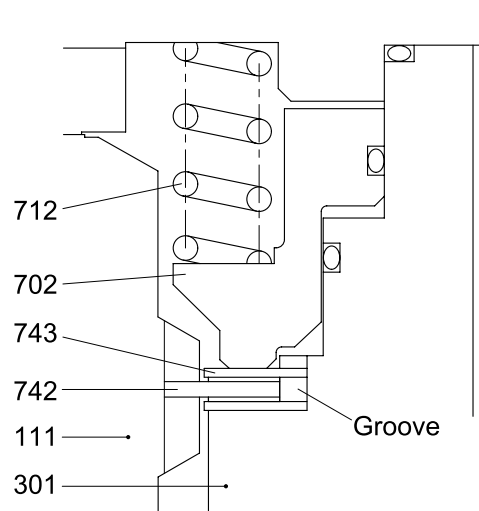

111	Cylinder	712	Brake spring
301	Casing	742	Friction plate
702	Brake piston	743	Separate plate

Operating principle

- a. When the swing control lever(1) is set to the swing position, the pilot oil go to the swing control valve(2) and to SH of the time delay valve(3) via the shuttle valve(4), this pressure move spool(5) to the leftward against the force of the spring(8), so pilot pump charged oil(P3) goes to the chamber G.

This pressure is applied to move the piston(702) to the upward against the force of the spring(712). Thus, it releases the brake force.

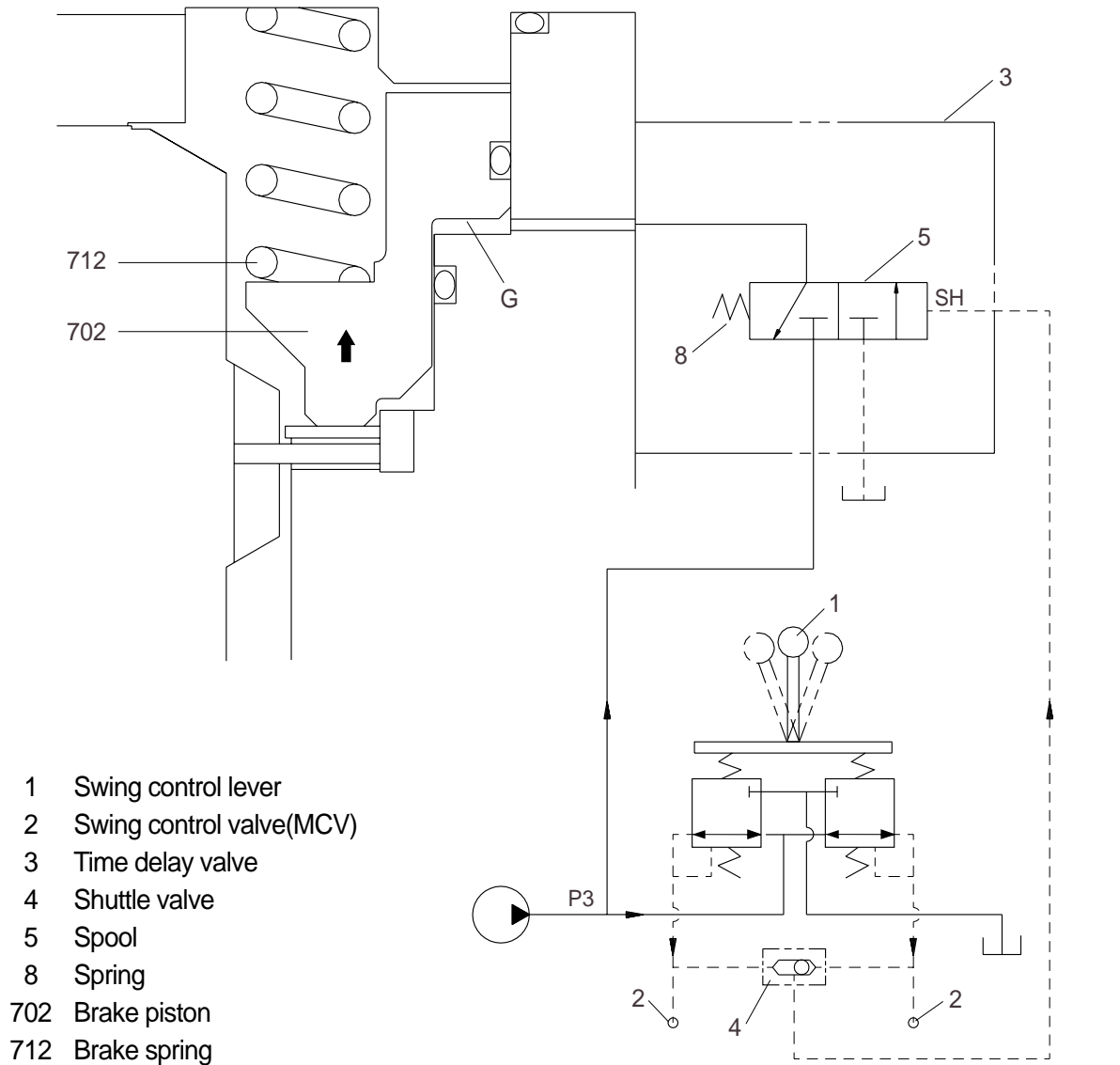

R290SM07(1)

- b. When the swing control lever(1) is set the neutral position, the time delay valve(3) shifts the neutral position and the pilot oil blocked chamber G.
- Then, the piston(702) is moved lower by spring(712) force and the return oil from the chamber G is drain.

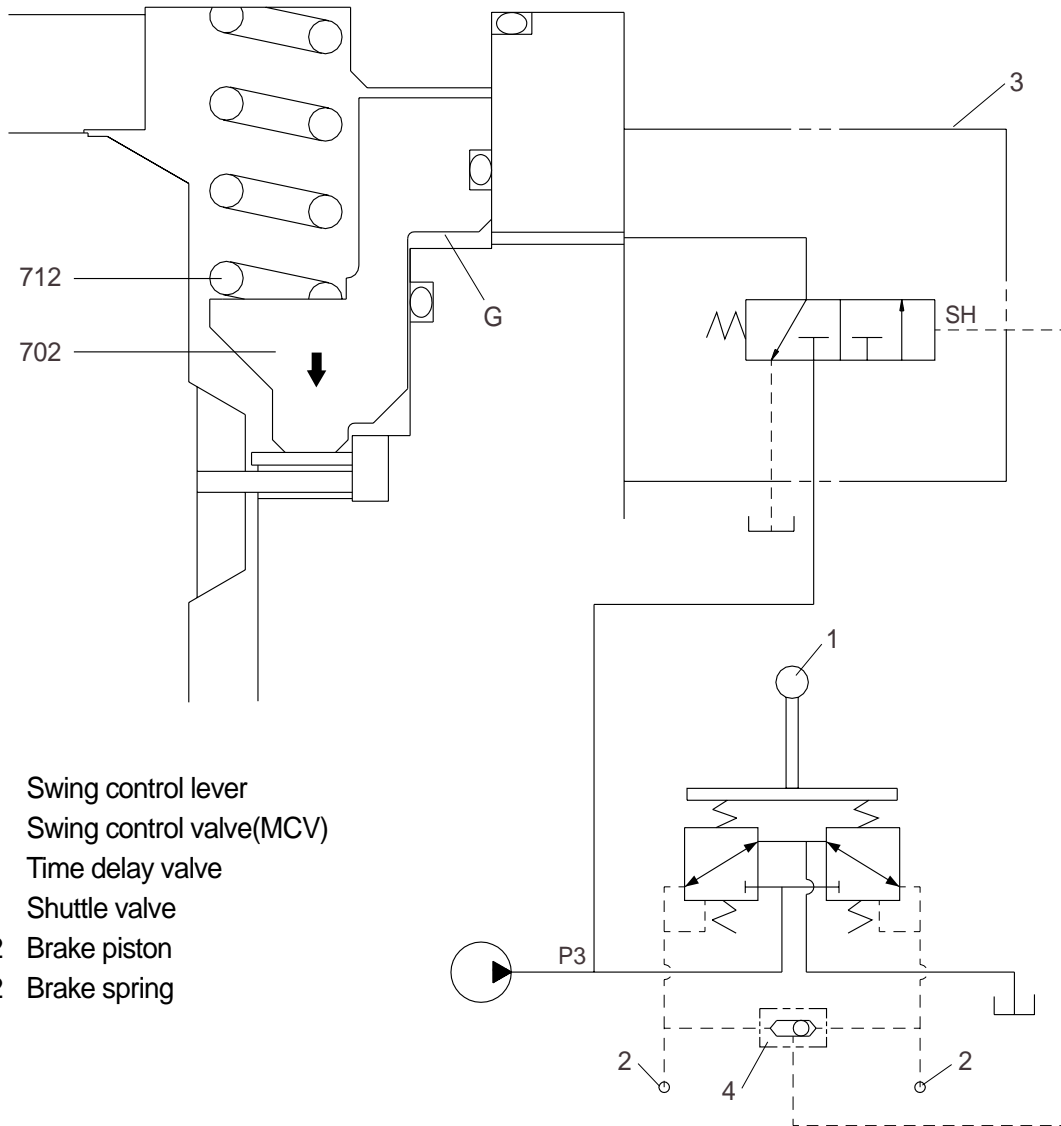

- 1 Swing control lever
- 2 Swing control valve(MCV)
- 3 Time delay valve
- 4 Shuttle valve
- 702 Brake piston
- 712 Brake spring

R290SM08(1)