

## GROUP 4 TRAVEL DEVICE (#0307 and up)

### 1. CONSTRUCTION

Travel device consists travel motor and gear box.

Travel motor includes brake valve, parking brake and high/low speed changeover mechanism.

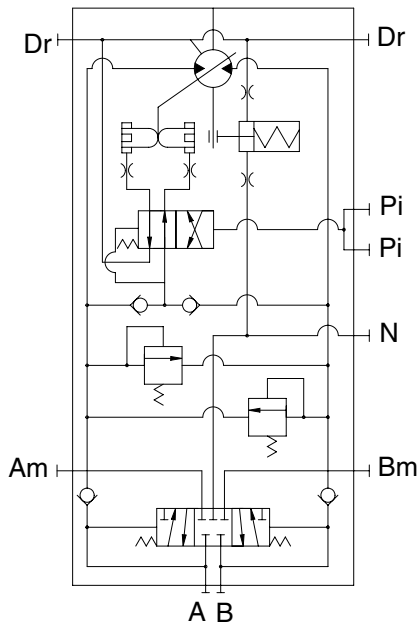
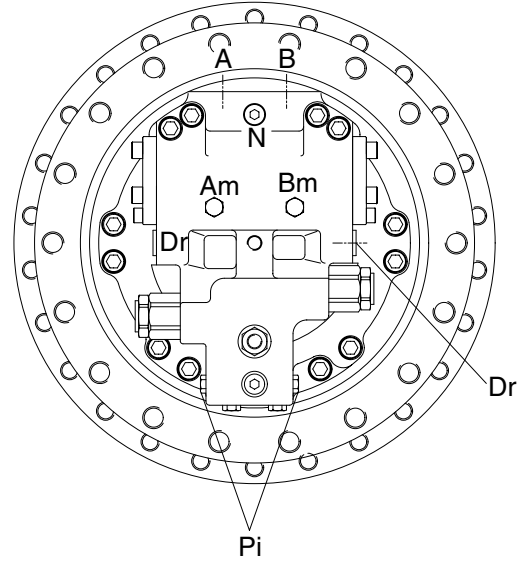
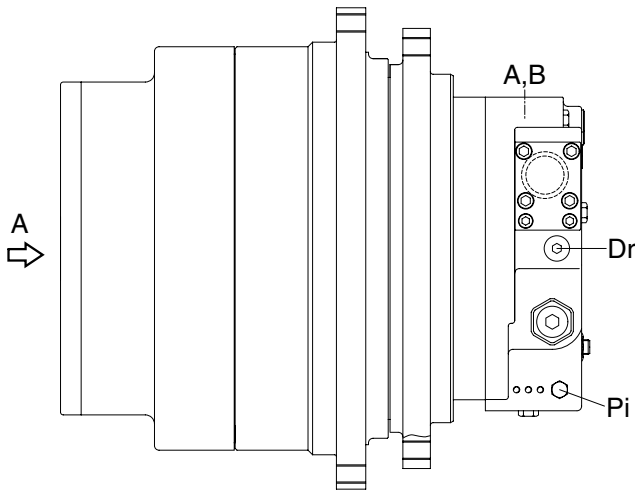

CIRCUIT DIAGRAM

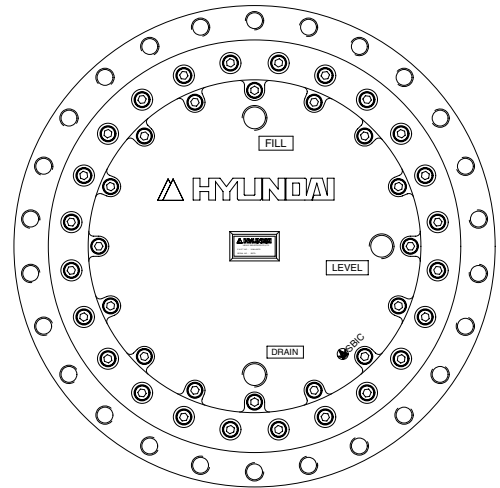

VIEW A

300072TM01A

Port	Port name	Port size
A, B	Valve port	PF 1
Pi	Pilot port	PF 1/4
Dr	Drain port	PF 1/2
Am, Bm	Gage port	PF 1/4
N	Parking release port	PF 1/4

## 2. SPECIFICATION

### 1) TRAVEL MOTOR

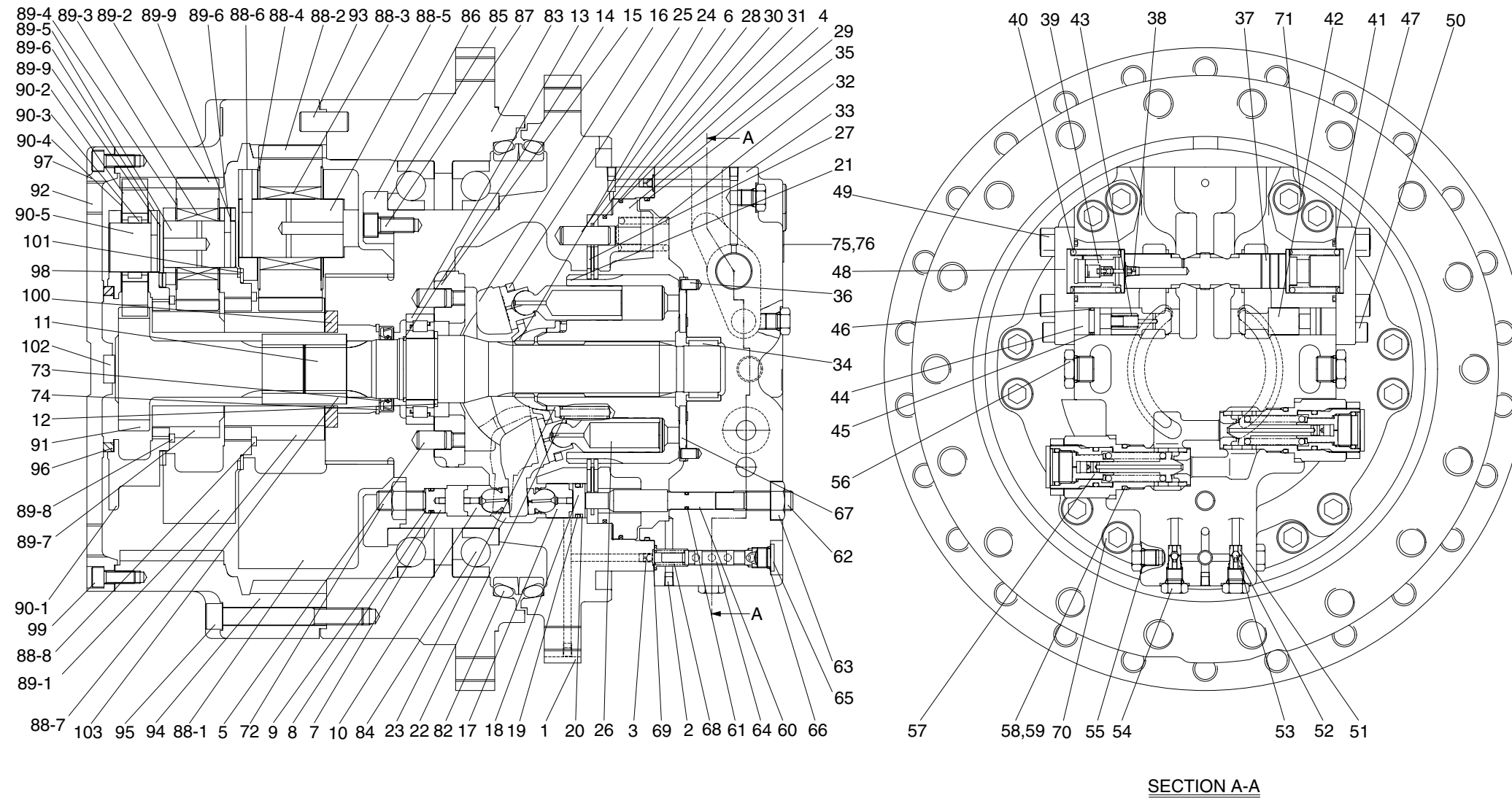

SECTION A-A

29092TM30

1 Casing	16 Plate	31 Ring	46 Back up ring	61 O-ring	83 Housing	89-1 Carrier No.2	91 Sun gear No.1
2 Plug	17 Piston	32 Spring	47 Cap	62 Lock screw	84 Bearing	89-2 Planetary gear No.2	92 Plug
3 Screw	18 Stopper	33 Valve casing	48 Cap	63 Nut	85 Shim	89-3 Needle No.2	93 Lock pin
4 Screw	19 O-ring	34 Needle bearing	49 Bolt	64 Spool	86 Retainer	89-4 Thrust washer No.2	94 Ring gear
5 Pin	20 Back up ring	35 O-ring	50 Socket bolt	65 Plug	87 Bolt	89-5 Pin No.2	95 Bolt
6 Pin	21 Cylinder block	36 Pin	51 Seat	66 O-ring	88 Carrier No.3	89-6 Spring pin No.2	96 Thrust ring No.1
7 Stopper	22 Cylinder spring	37 Spool	52 Steel ball	67 Valve plate	88-1 Carrier No.3	89-7 Sun gear No.2	97 Cover
8 O-ring	23 Spacer	38 Screw	53 Stopper	68 Spring	88-2 Planetary gear No.3	89-8 Snap ring No.2	98 Thrust ring No.2
9 Back up ring	24 Guide	39 Damping check	54 Plug	69 O-ring	88-3 Needle No.3	89-9 Spring pin No.2	99 Bolt
10 Piston	25 Plate	40 Spring	55 O-ring	70 Socket bolt	88-4 Thrust washer No.3	90 Carrier No.1	100 Motor ring
11 Shaft	26 Piston & Shoe assy	41 O-ring	56 Plug	71 Socket bolt	88-5 Pin No.3	90-1 Carrier No.1	101 Thrust ring No.3
12 Spacer	27 Plate	42 Plunger	57 Relief valve	72 Lock screw	88-6 Spring pin No.3	90-2 Planetary gear No.1	102 Pad
13 Roller bearing	28 Plate	43 Spring	58 O-ring	73 Oil seal	88-7 Sun gear No.3	90-3 Needle bearing No.1	103 Coupling
14 Stop ring	29 Brake	44 Stopper	59 Back up ring	74 Lock ring	88-8 Snap ring No.3	90-4 Thrust washer No.1	
15 Support	30 Ring	45 O-ring	60 Rod	82 Floating Seal	89 Carrier No.2	90-5 Pin No.1	

### 3. PRINCIPLE OF DRIVING

#### 1) WORKING OF ROTARY GROUP

The high pressurized hydraulic oil which is supplied from a hydraulic pump is flows into a cylinder (21) through the valve casing (33) of motor, and valve plate (67).

The rotary group has a construction that the above high pressurized hydraulic oil is flow only one side of the line Y-Y which connect the upper and lower dead point of the piston (26).

This high pressurized hydraulic oil works on the piston and generating the force  $F1$ ,  $F1 = P * A$  ( $P$  : supplied pressure,  $A$  : pressure receiving area), like following pictures.

This force,  $F1$ , is divided by the swash plate (16) having a tilting angle  $\alpha$  into the thrust component  $N1$  and radial component  $W1$ .

The  $W1$  generates torque,  $T = W1 * R1$ , in respect to the line Y-Y.

This torque generated by each piston on the high pressurized hydraulic oil side is summed up onto a resultant torque  $\Sigma (W1 * R1)$ , which prodeces torque for rotation.

This torque transfers the rotation force to the cylinder (21) through the pistons.

Since the cylinder block is spline-coupled with the shaft, the rotation force is transmitted to the shaft accordingly.

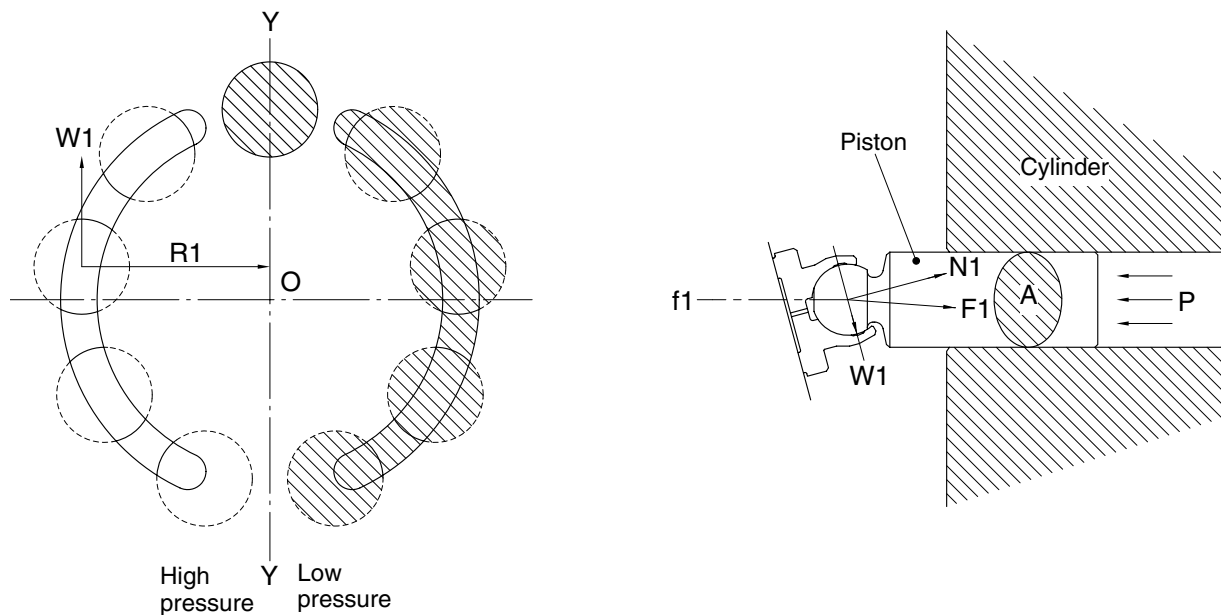

2907A2TM07

## 2) WORKING OF RELIEF VALVE

Relief valve carries on two function of following.

- (1) Relief valve is to keep the starting pressure of the hydraulic motor at a constant value and bypass to the return line excessive oil generated at the motor inlet depending upon the acceleration speed of the inertia object.
- (2) In case of an inertia object stopped, relief valve is generating a break pressure at the outlet and stop it forcedly.

The chamber A is always connect with port A of a motor. When the pressure at port A increase and the force pushing poppet A is higher than the pressure of the spring, then poppet A is pushed up from the contact surface of seat A, and oil flows from chamber A to port B.

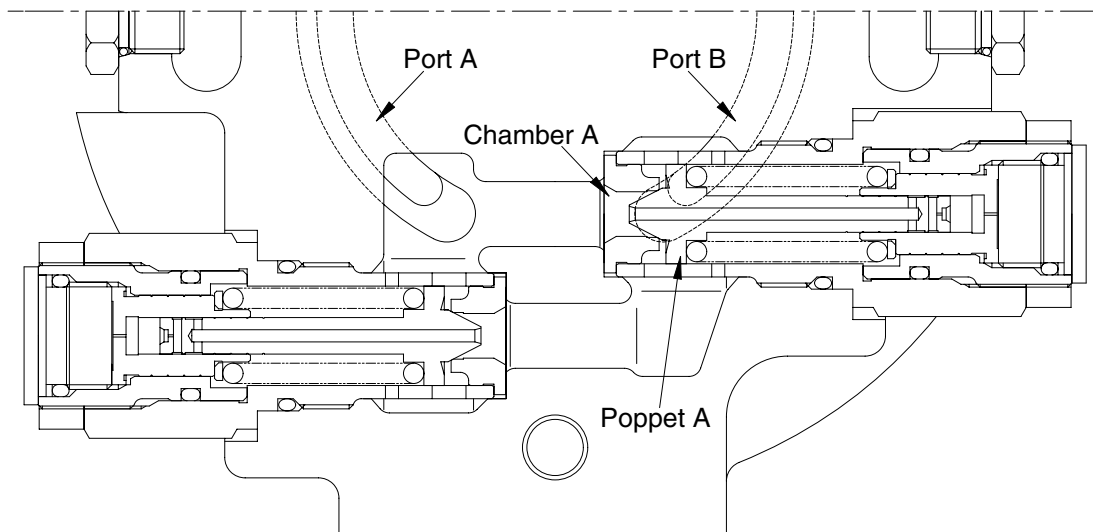

2907A2TM04

### 3) WORKING OF NEGATIVE BRAKE

The negative brake is released applying to the brake piston (29) the pressure led through built in the valve casing (33) spool. With no pressure working, the brake force is always ensured.

The brake force is generated by the frictional force among a plate (28) fixed by pin (6) and shaft casing, brake piston (29) and a frictional plate (27) connected through spline outside the cylinder block (21).

Without pressure being applied to the brake piston, the brake piston is pushed by ten brake springs (32) and the friction plate and separator plate are held between the brake piston and casing. This friction force restrains the shaft (11) spline-coupled with the cylinder block, and thus functions the brake.

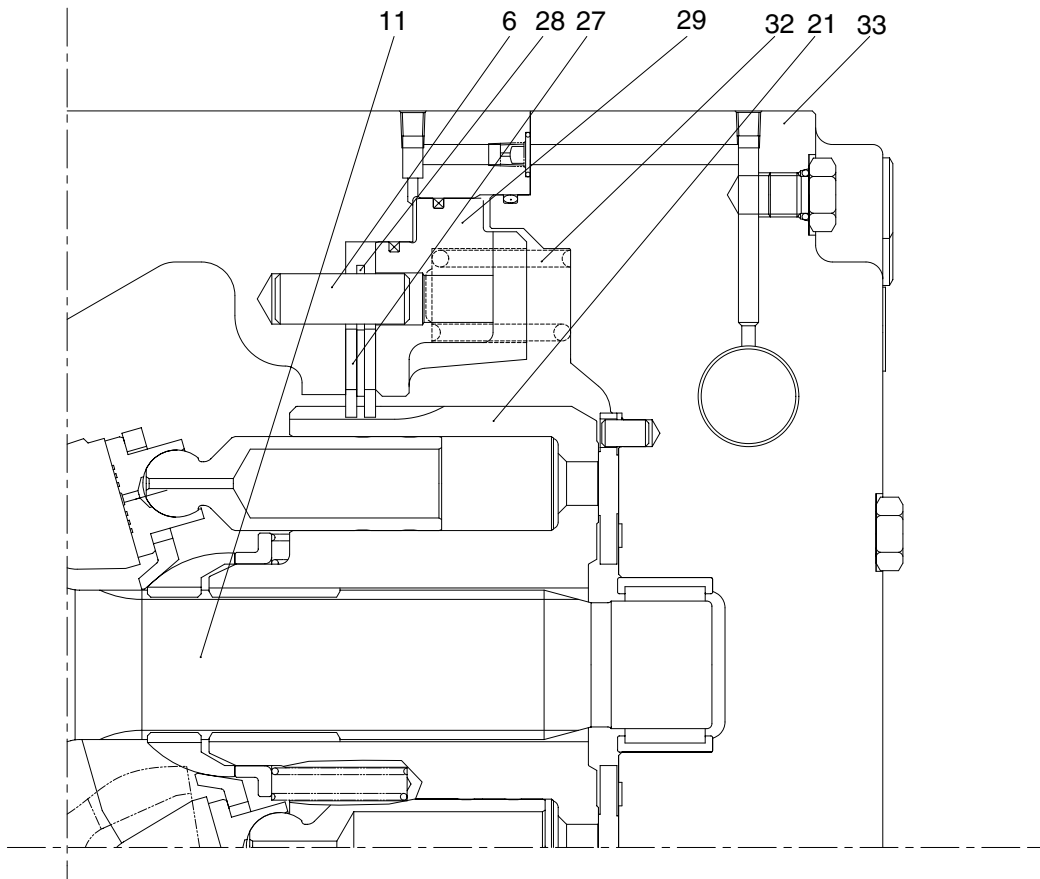

300075TM05

#### 4) COUNTERBALANCE VALVE

Av port is connected to a hydraulic pump : Bv port is connected to a tank.

The oil supplied from the hydraulic pump passed through Av → Cv → C sequence, pushed up the poppet of the check valve, passed through L to port AM, and is supplied to the hydraulic motor to turn it. But the brake is operated. Therefore, the pump discharge oil pressure is increases. And the pressure is led via passage G to spring room M. When the pressure in room M exceed the value equivalent to the force of the spring which holds the spool at its neutral position, the spool begins to move right.

The oil in room N is sent to room Dv by orifice I and discharged from Bv port to a tank. So spool moves to the right. The oil flows as the way of K → Dv → Bv sequence. Also according to the oil path as composed way Cv → H → P sequence, the pressure of Av pump is provided to the port P. An working oil in room N is discharged through orifice and a gap. Therefore the switching operation of spool is driving slowly.

When the pump discharge pressure fall, spool moves to the left side by a spring at the side of room N. Also spool moves to the left, the hydraulic oil in room M is sent to Cv room through orifice I' and discharged to the Av port.

When the pressure at port Av fall down to the tank pressure, the pressure of room M is as the same as that the tank pressure and becomes equal to that in room N, and so the spool returns to its neutral position.

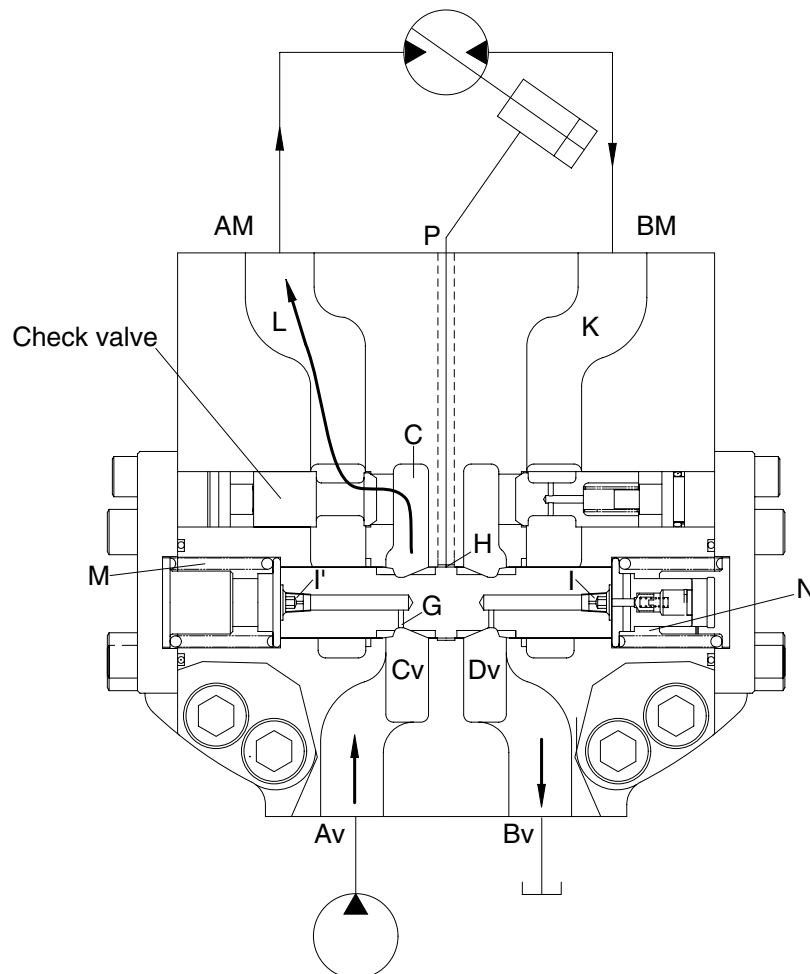

300072TM06

## 5) WORKING OF DISPLACEMENT CHANGEOVER

The capacity of the travel motor is changed by changing the tilting angle of this swash plate (16). The tilting angle changes by displacement changeover valve.

(1) External pilot pressure :  $P_i = 0$  (large displacement)

By means of the built-in high pressure selector mechanism in the valve casing (33), the high pressure oil working on the motor function to port P of the displacement-changeover valve.

A the spool (64) assembled in the displacement changeover valve is pressed to plug (65) by the spring (68), the high pressure oil at port P flows to port Sb.

This high pressure oil flows through oil passage (passage A') of valve casing (33) and shaft casing works to chamber A.

This oil in chamber B flows through passage B' and port Sa into the drain line. The displacement changeover piston (17) is pushed right and the swash plate (16) moves in the arrowed direction around rotation center 'O'. The swash plate moves until it touched stopper (18), and then is fixed there.

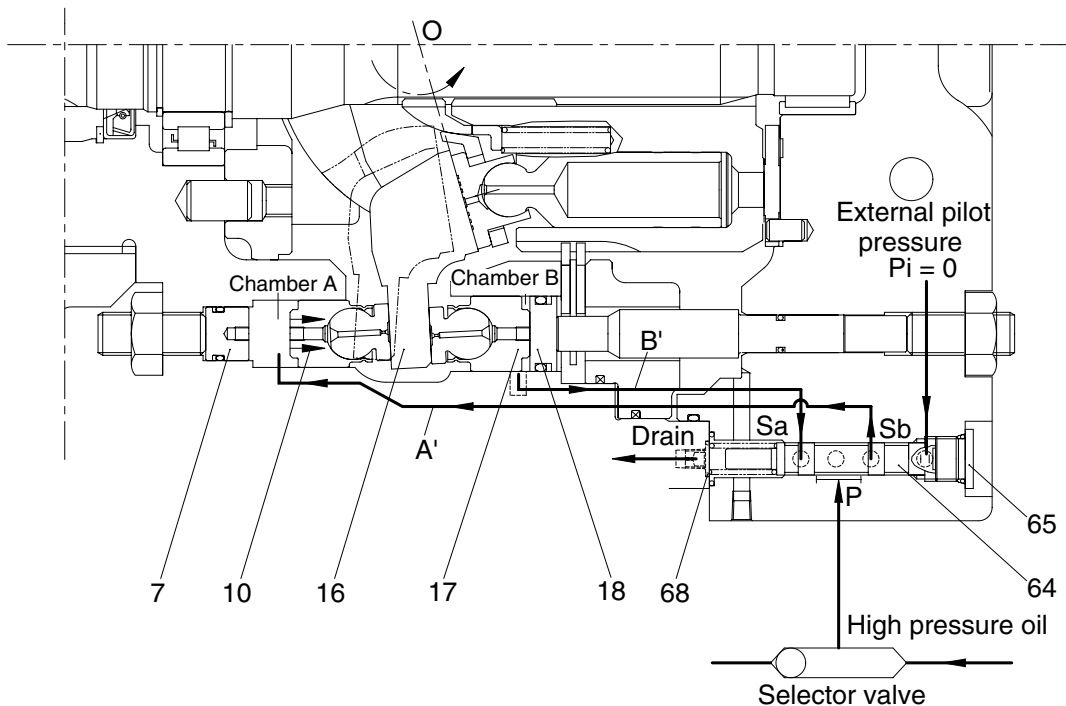

2907A2TM05

(2) External pilot pressure :  $P_i \geq 20\text{kgf/cm}^2$  (small displacement)

If the force operating on spool (64) of the displacement changeover valve is stronger than the spring (68), and the spool moves to the left side.

The high pressure oil works on room B through passage  $S_a \rightarrow B'$  from port P.

The oil in chamber A flows into the drain line through the passage  $A' \rightarrow S_b$ .

The displacement changeover piston (17) is pushed left and the swash plate (16) moves in the arrowed direction around rotation center 'O'. The swash plate moves until it touches stopper (7), and then is fixed there.

If the load increase while the motor is working with its small displacement ( $P_i \geq 20\text{kgf/cm}^2$ , 2nd speed) until the motor inlet port pressure reaches the preset value, the motor increase its displacement in response to the load, while maintaining the pressure at the preset value (automatic 2 -speed function). As motor inlet port pressure reaches the preset value and then spool (64) moves right side, inlet pressure oil flows into chamber A through port  $S_b$  and the swash plate moves until it touches stopper (17). If the load further increase until the displacement of the motor reaches the maximum value, the inlet port pressure increase further.

If the load decreases under this condition, the motor continues reducing its displacement in the reverse sequence. As the load and inlet port pressure decreases and reaches the preset value, spool (64) moves left side by the pilot pressure ( $P_i$ ). Therefore inlet port pressure flow into chamber B through port  $S_a$  and the swash plate moves until it touches stopper (10).

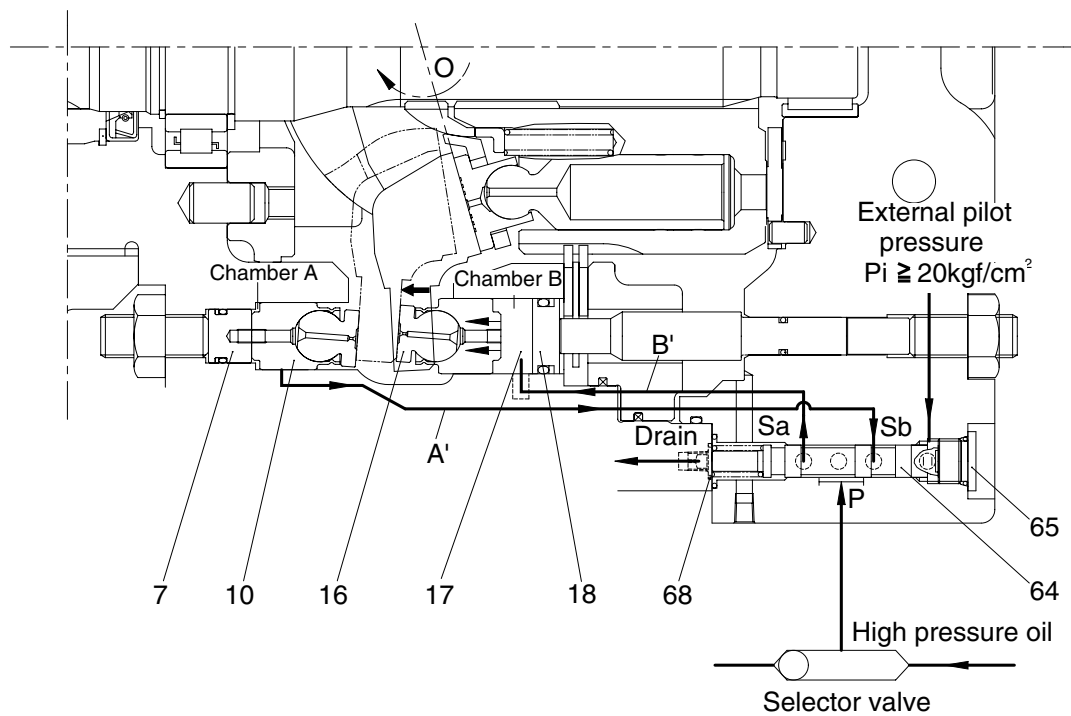

2907A2TM06

## 6) REDUCTION GEAR

### (1) Planetary gear mechanism

Reduction unit slows down the rotating speed of motor and converts motor torque to strong rotating force.

This reduction unit utilizes two stages, planetary reduction system.

Planetary reduction system consists of sun gear, planetary gears, carriers and ring gear.

When the sun gear (s) is driven through input shaft, planetary pinions (b), rotating on their center, also move, meshing with fixed ring gear (a), around sun gears (s).

This movement is transferred to carrier (k) and deliver the torque.

This mechanism is called planetary gear mechanism.

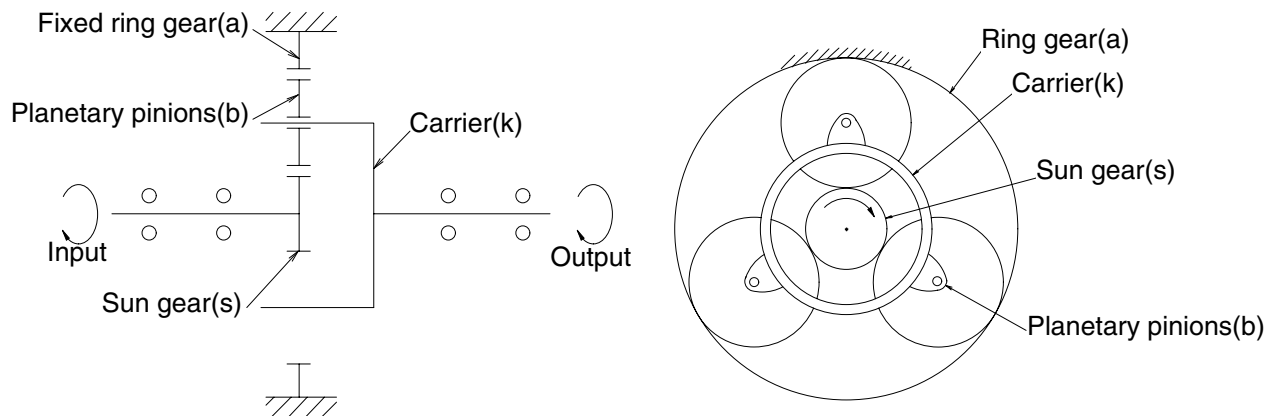

29072TM10

29072TM11

### (2) Two stages reduction gear

When the sun gear S1 is driven by input shaft, planetary action occurs among gears S1, a and b and revolution of gear b transfers the rotation of carrier K1 to second sun gear S2, and also evokes planetary action between gear S2, a and d.

This time, because carrier K2 is fixed to frame, gear d drives ring gear a and then ring gear a rotates to drive sprocket.

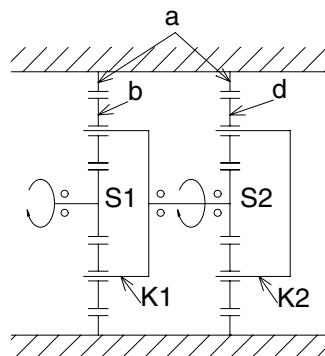

29072TM12