

P1 BLOCK SPOOL SECTION

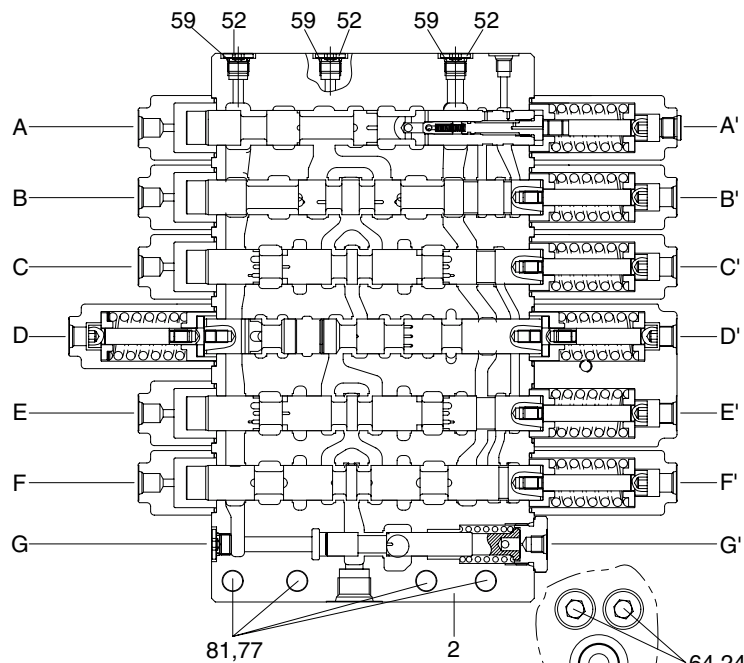

P2 BLOCK SPOOL SECTION

- 1 Housing (P1)
- 2 Housing (P2)
- 24 Plug
- 43 Orifice-signal
- 44 Coin type filter
- 50 O-ring
- 52 Plug
- 59 O-ring
- 64 O-ring
- 65 O-ring
- 76 Socket bolt
- 77 Hex socket head bolt
- 78 Hex socket head bolt
- 81 Spring washer
- 86 Poppet
- 87 Spring check
- 88 Plug

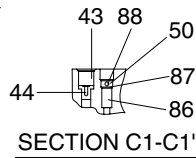
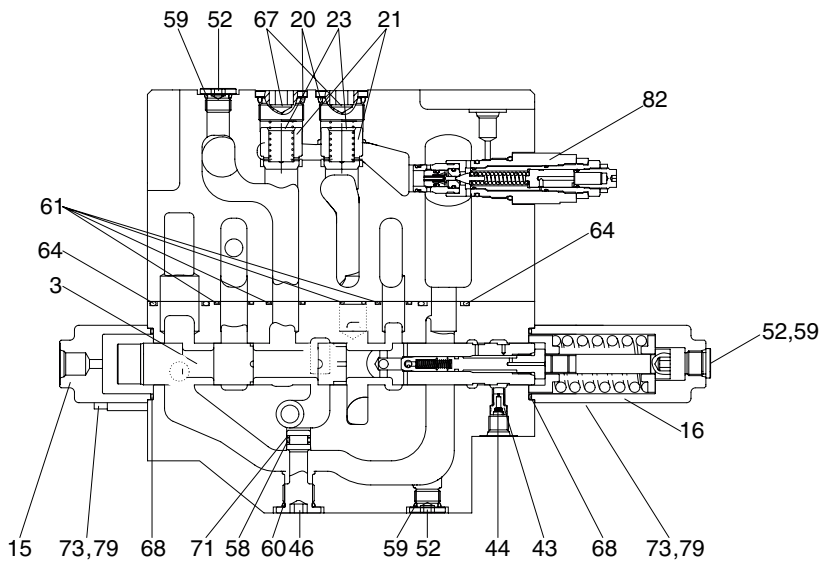

A-A' (STRAIGHT-TRAVEL & SUPPLY)

- 3 Spool-straight
- 4 Spool-travel
- 15 Cover-pilot A
- 16 Cover-pilot B1
- 20 Plug
- 21 Poppet 1-check valve
- 23 Spring 1-check valve
- 24 Plug
- 43 Orifice-signal
- 44 Coin type filter
- 46 Plug
- 47 Plug
- 52 Plug
- 54 Plug
- 57 O-ring
- 58 O-ring
- 59 O-ring
- 60 O-ring
- 61 O-ring
- 62 O-ring
- 64 O-ring
- 65 O-ring
- 67 O-ring
- 68 O-ring
- 71 Back-up ring
- 72 Back-up ring
- 73 Hex socket head bolt
- 79 Washer
- 82 Main relief valve

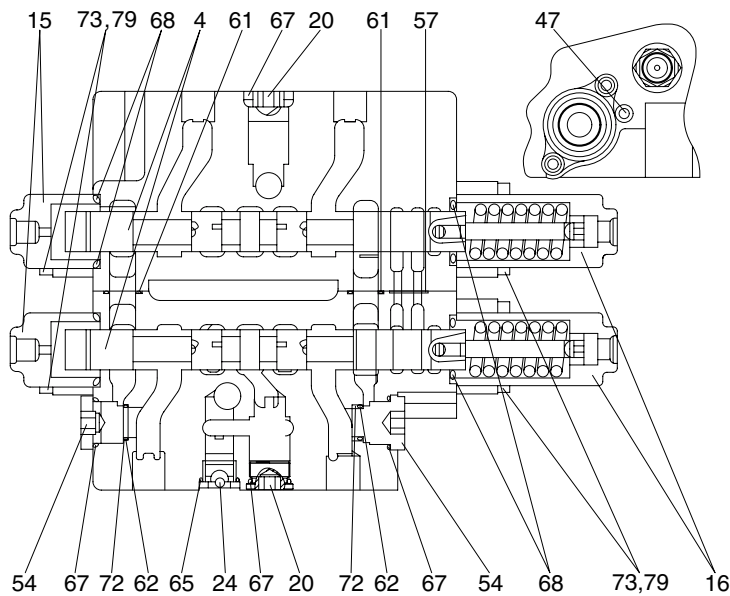

B-B' (TRAVEL RIGHT & LEFT)

300H2MC11

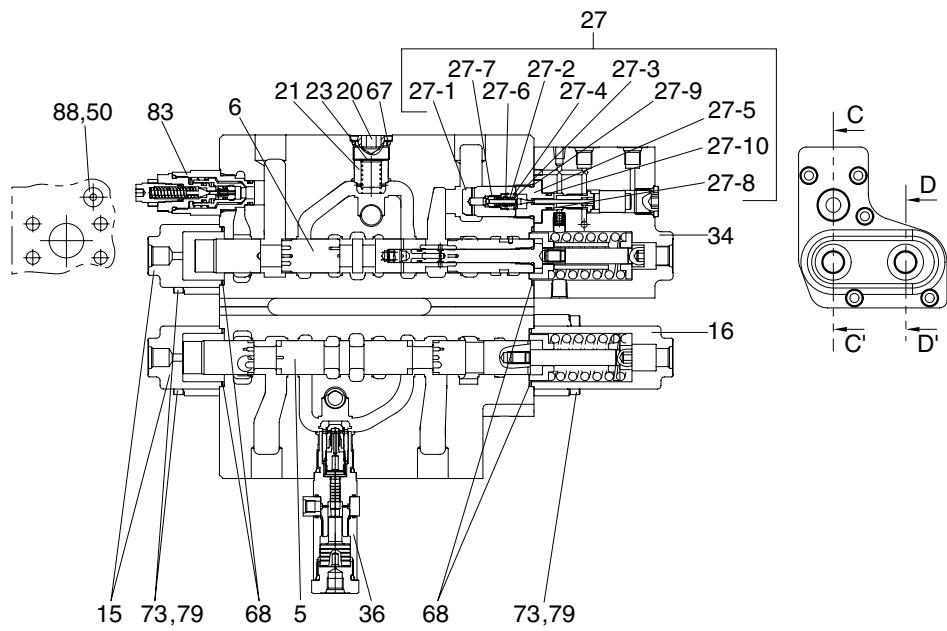

C-C' (SWING & BOOM1)

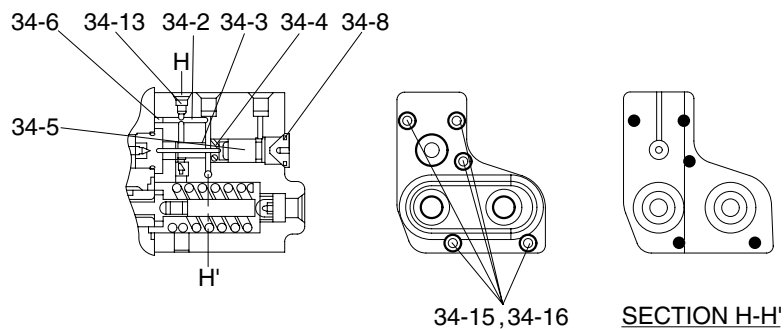

34 DETAIL (HOLDING ASSY)

300H2MC12

5	Spool-swing	27-7	Restrictor-lock valve	34-14	Plug
6	Spool-boom	27-8	O-ring	34-15	Socket bolt
15	Cover-pilot A	27-9	O-ring	34-16	Spring washer
16	Cover-pilot B1	27-10	Back up ring	36	Logic valve
20	Plug	34	Holding kit-A1	50	O-ring
21	Poppet 1-check valve	34-1	Block-H/D P1	56	O-ring
23	Spring 1-check valve	34-2	Piston 1-holding	66	O-ring
27	Holding kit-B	34-3	Guide piston-holding	67	O-ring
27-1	Poppet	34-4	Spring 1-lock valve	68	O-ring
27-2	Spring	34-5	Piston 2-holding	70	Back-up ring
27-3	Poppet guide	34-6	Plug	73	Hex socket head bolt
27-4	Pilot poppet	34-7	Plug	79	Washer
27-5	Poppet seat	34-8	Plug	83	Overload relief valve
27-6	C-ring	34-13	Plug	88	Plug

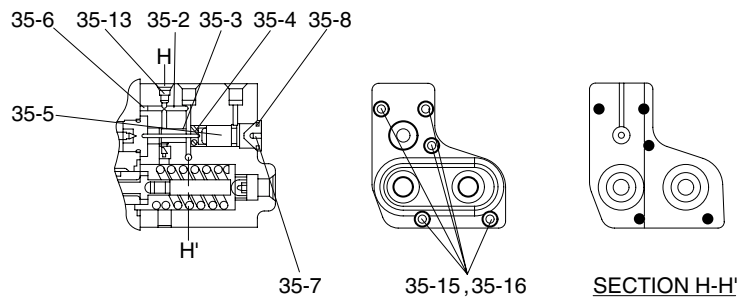
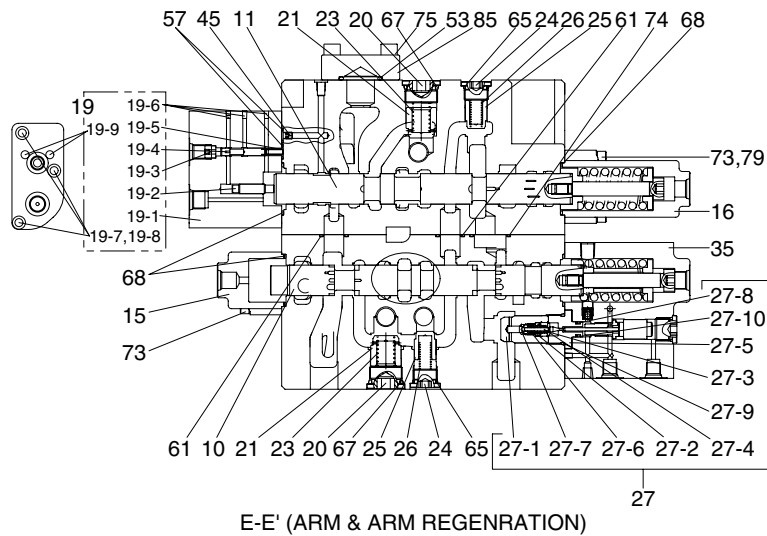

35 DETAIL (HOLDING ASSY)

300H2MC13

10	Spool-arm	27	Poppet-lock valve	35-13	Plug
11	Spool-arm regeneration	27-1	Poppet	35-15	Socket bolt
15	Cover-pilot A	27-2	Spring	35-16	Spring washer
16	Cover-pilot B1	27-3	Poppet guide	45	Orifice-plug
19	Arm-regeneration	27-4	Pilot poppet	53	Flange
19-1	Block-regeneration	27-5	Poppet seat	56	O-ring
19-2	Piston-cut off	27-6	C-ring	57	O-ring
19-3	Stopper-regeneration	27-7	Restrictor-lock valve	61	O-ring
19-4	Spool-regeneration	27-8	O-ring	65	O-ring
19-5	Spring-regeneration	27-9	O-ring	66	O-ring
19-6	Plug	27-10	Back up ring	67	O-ring
19-7	Socket bolt	35	Holding kit-A2	68	O-ring
19-8	Spring wahser	35-1	Block-H/D P2	70	Back-up ring
19-9	Pin-regeneration	35-2	Piston 1-holding	73	Hex socket head bolt
20	Plug	35-3	Guide piston-holding	74	O-ring
21	Poppet 1-check valve	35-4	Spring 1-lock valve	75	Socket bolt
23	Spring 1-check valve	35-5	Piston 2-holding	79	Washer
24	Plug	35-6	Plug	85	O-ring
25	Poppet 2-check valve	35-7	Plug		
26	Spring 2-check valve	35-8	Plug		

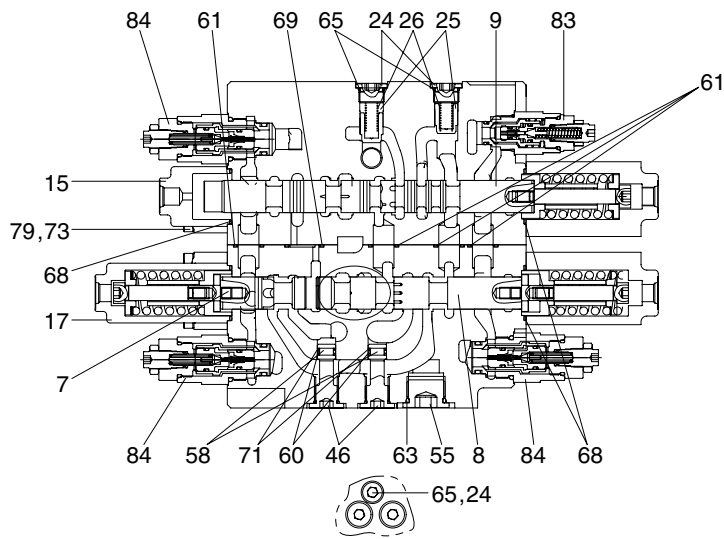

D-D' (SWING PRIORITY-BOOM2 & ARM2)

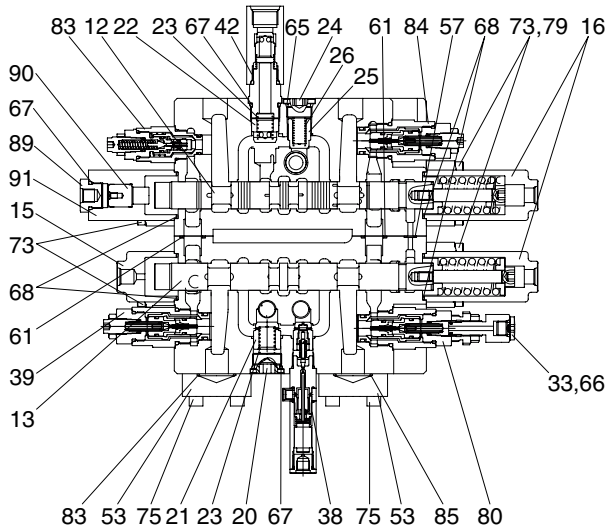

F-F' (OPTION & BUCKET)

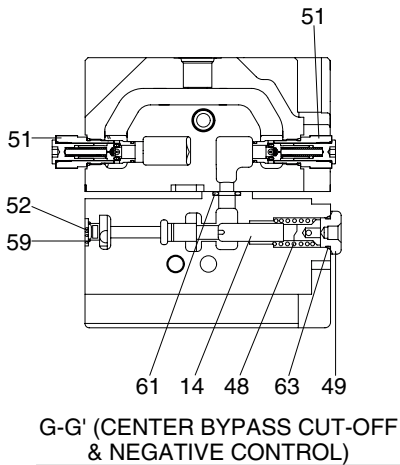

G-G' (CENTER BYPASS CUT-OFF & NEGATIVE CONTROL)

- 7 Spool-swing priority
- 8 Spool-boom 2
- 9 Spool-arm 2
- 12 Spool-bucket
- 13 Spool-option
- 14 BC spool
- 15 Cover-pilot A
- 16 Cover-pilot B1
- 17 Cover-pilot B2
- 20 Plug
- 21 Poppet 1-check valve
- 22 Poppet L/C-bucket
- 23 Spring 1-check valve
- 24 Plug
- 25 Poppet 2-check valve
- 26 Spring 2-check valve
- 38 Load check valve assy
- 39 Overload relief valve
- 42 Check valve
- 46 Plug
- 48 Spring-BC spool
- 49 Plug-BC spool
- 51 Negative control valve
- 52 Plug
- 53 Flange
- 55 Plug
- 57 O-ring
- 58 O-ring
- 59 O-ring
- 60 O-ring
- 61 O-ring
- 63 O-ring
- 65 O-ring
- 67 O-ring
- 68 O-ring
- 69 O-ring
- 71 Back-up ring
- 73 Hex socket head bolt
- 75 Socket bolt
- 79 Washer
- 80 Overload relief valve
- 83 Overload relief valve
- 84 Overload relief valve
- 85 O-ring
- 89 Plug
- 90 Piston
- 91 Pilot cover C1

300H2MC14



### 3. FUNCTION

#### 1) CONTROL IN NEUTRAL

##### (1) P1 SIDE

The hydraulic fluid from pump flows into the main control valve through the inlet port "P1", pass the land of the travel straight spool, into the P1 bypass passage and P1 parallel passage. When the straight travel spool is in neutral position, the bypass passage is not shut off. Then the hydraulic fluid from the pump P1 is directed to the tank through the bypass passage of spools : travel right, boom 1, arm 2, arm regeneration & option A and bucket, the negative relief valve of P1, tank passage, and the tank port "T1"

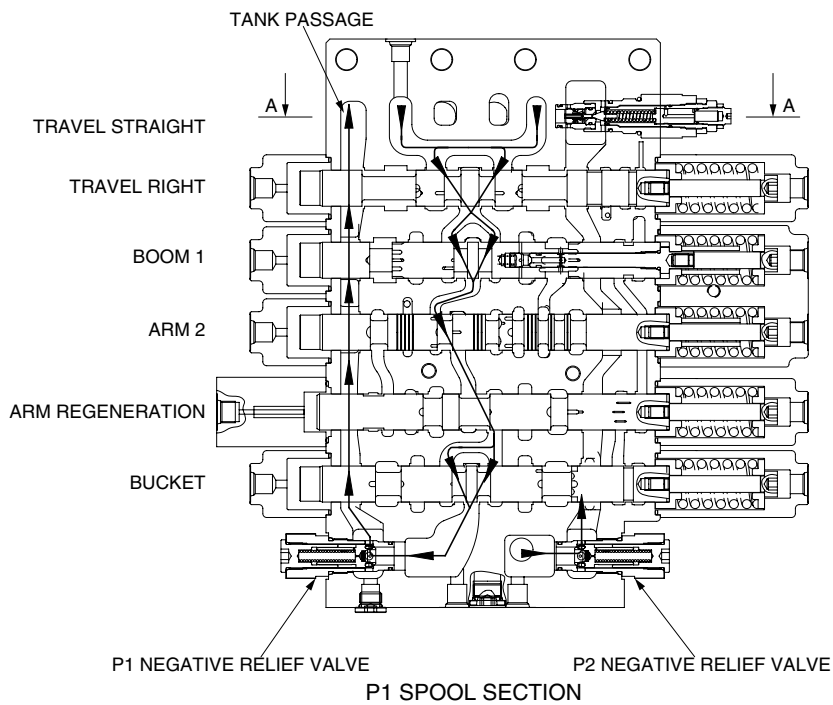

29092MC03B

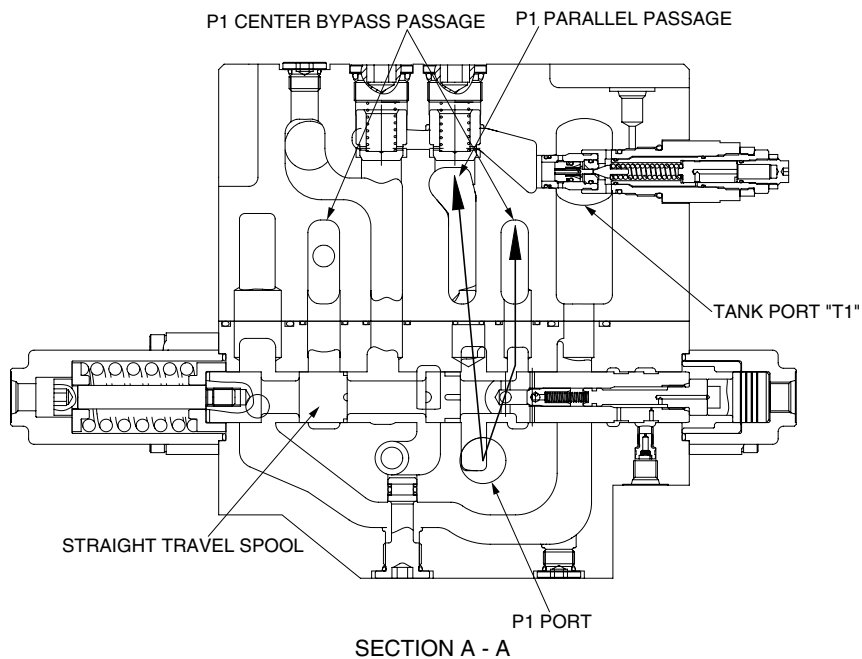

29092MC04

**(2) P2 SIDE**

The hydraulic fluid from pump flows into the main control valve through the inlet port "P2", pass the land of the straight travel spool, into the P2 bypass passage and P2 parallel passage. When the straight travel spool is in neutral position, the bypass passage is not shut off. Then the hydraulic fluid from the pump P2 is directed to the tank through the bypass passage of spools : travel left, swing, boom 2 & swing priority, arm 1, option "B" and option "C" of bypass passage summation, and the negative relief valve of P2, the tank passage and the tank port "T1".

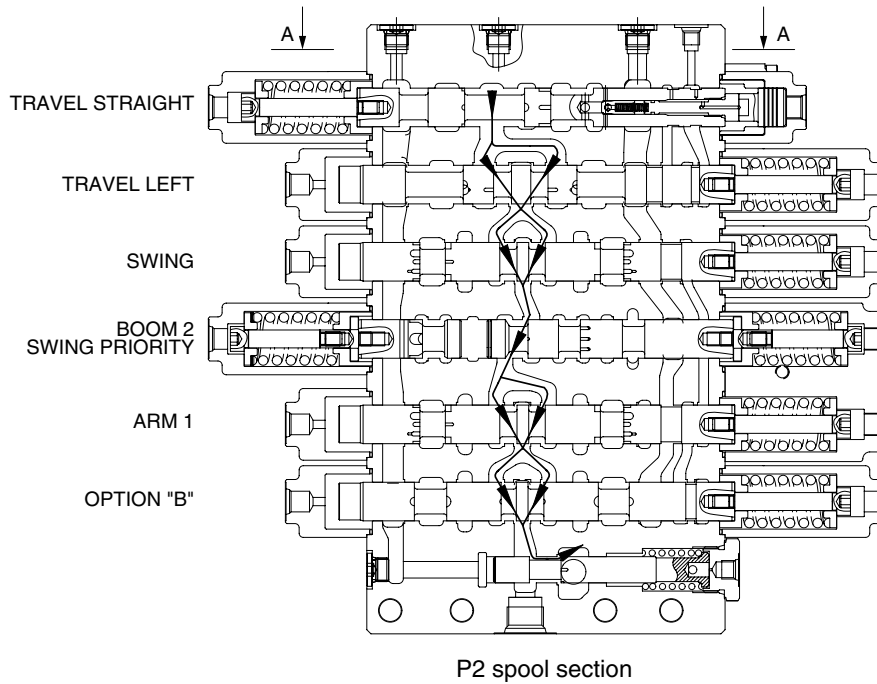

29092MC06

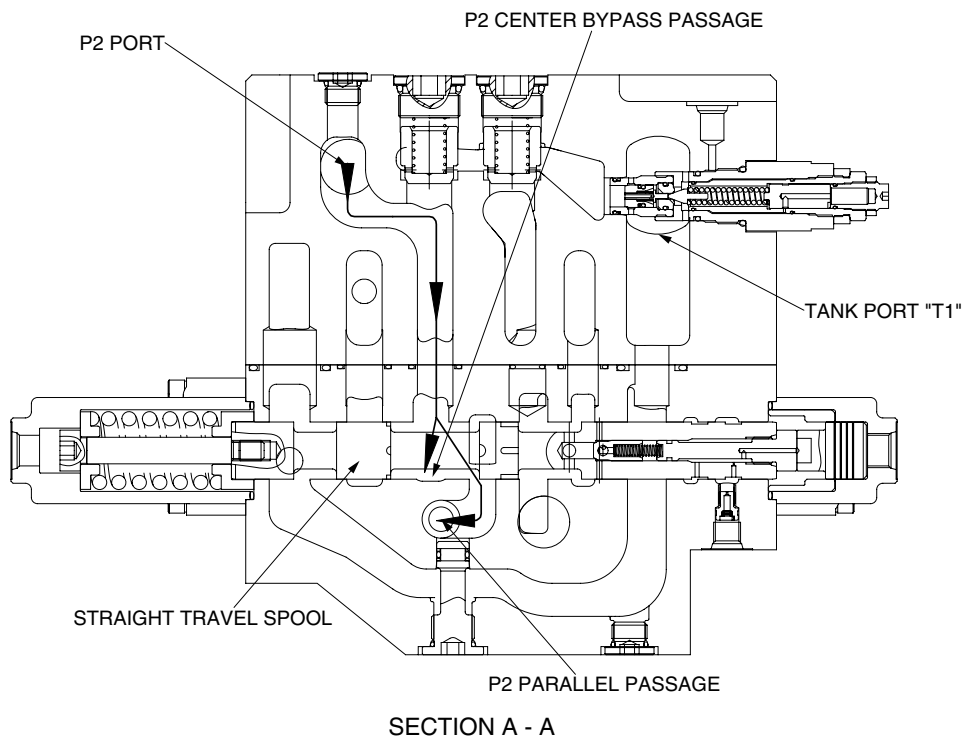

29092MC05A

## 2) TRAVEL OPERATION

### (1) TRAVEL FORWARD OPERATION

During the travel forward operation, the pilot pressure of RCV is supplied to the port of the spring side, and it shifts travel right and left spools in the left direction against springs. Hydraulic fluid from the pump flows into the bypass passage of travel spool through the land of the straight travel spool.

Then the bypass passage is shut off by the movement of the spool, they are directed to the each travel motor through port B1 and D1. At the same time, the hydraulic fluid from the each travel motor through port A1 and C1 returns to the tank passage through the travel spools.

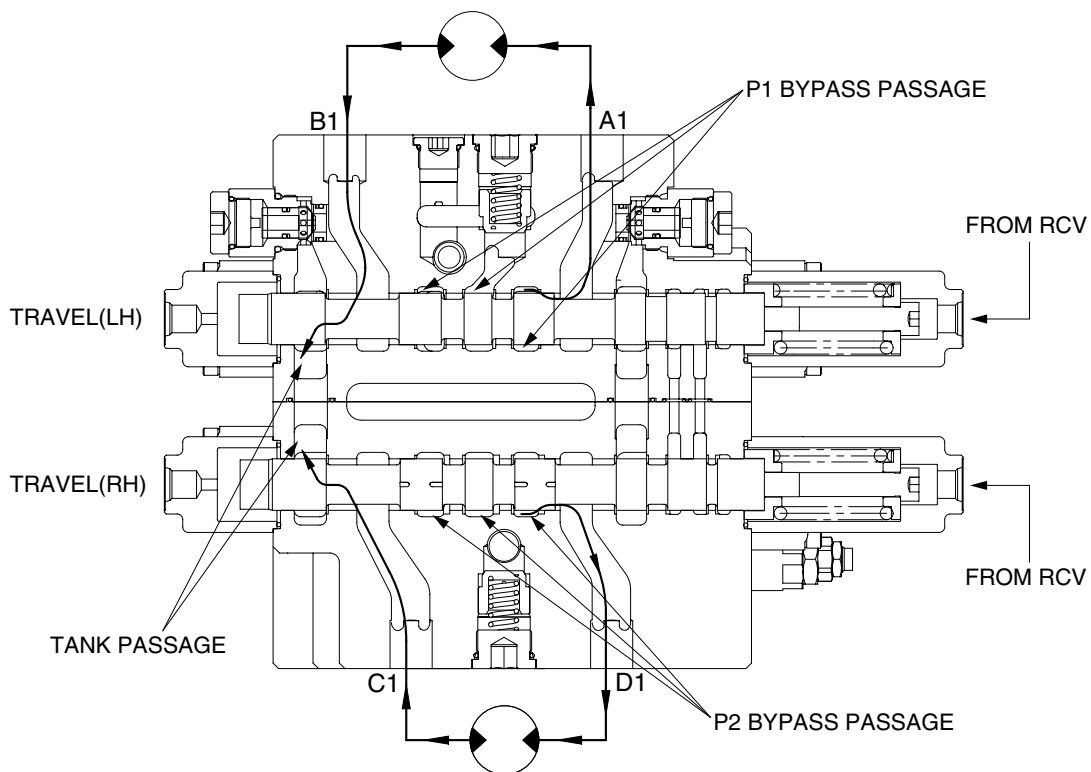

29092MC07

## (2) TRAVEL REVERSE OPERATION

During the travel reverse operation, the pilot pressure of RCV is supplied to the port of the spring opposite side, and it shifts travel right and left spools in the right direction against springs. Hydraulic fluid from the pump flows into the bypass passage of travel spool through the land of the straight travel spool.

Then the bypass passage is shut off by the movement of the spool, they are directed to the each travel motor through port A1 and C1. At the same time, the hydraulic fluid from the each travel motor through port B1 and D1 returns to the tank passage through the travel spools.

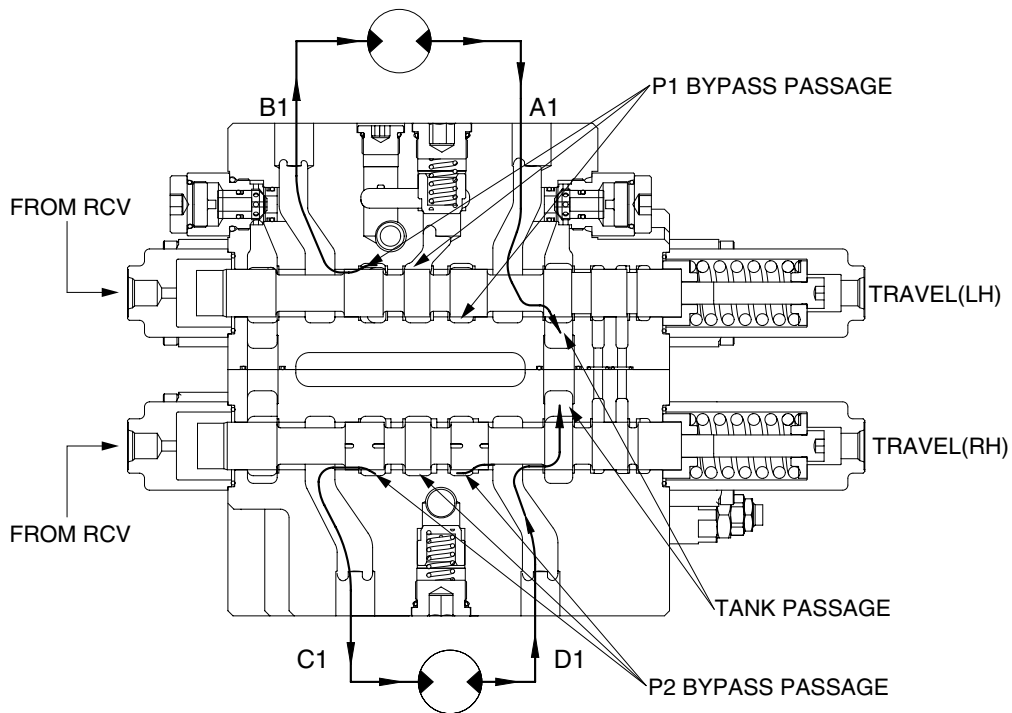

29092MC08

### (3) TRAVEL STRAIGHT FUNCTION

Straight travel valve is the valve for keeping traveling straight when boom, arm, bucket or swing is operated at the time of traveling. Therefore the oil from the P1 and P2 pump flows into the control valve through the each passage in neutral condition.

When the both travels and any of attachment is switched, the pilot pressure is applied the port of spring chamber and the travel straight spool is shifted.

When the straight travel spool is shifted, the oil pressure from P1 is led to the each attachment switching section through the P1 and P2 parallel passage. Also some of oil id combined with bypass of P1 side by opening of check valve of spool inside through the orifice of the straight travel spool.

On the other hand, the oil from P2 is supplied to the both travel section through P1 and P2 bypass passage.

Therefore, when attachment is switched at the time of both travels, since the oil of P2 mainly flows to both travels, and the oil of P1 mainly flows to attachments, it can keep traveling straight.

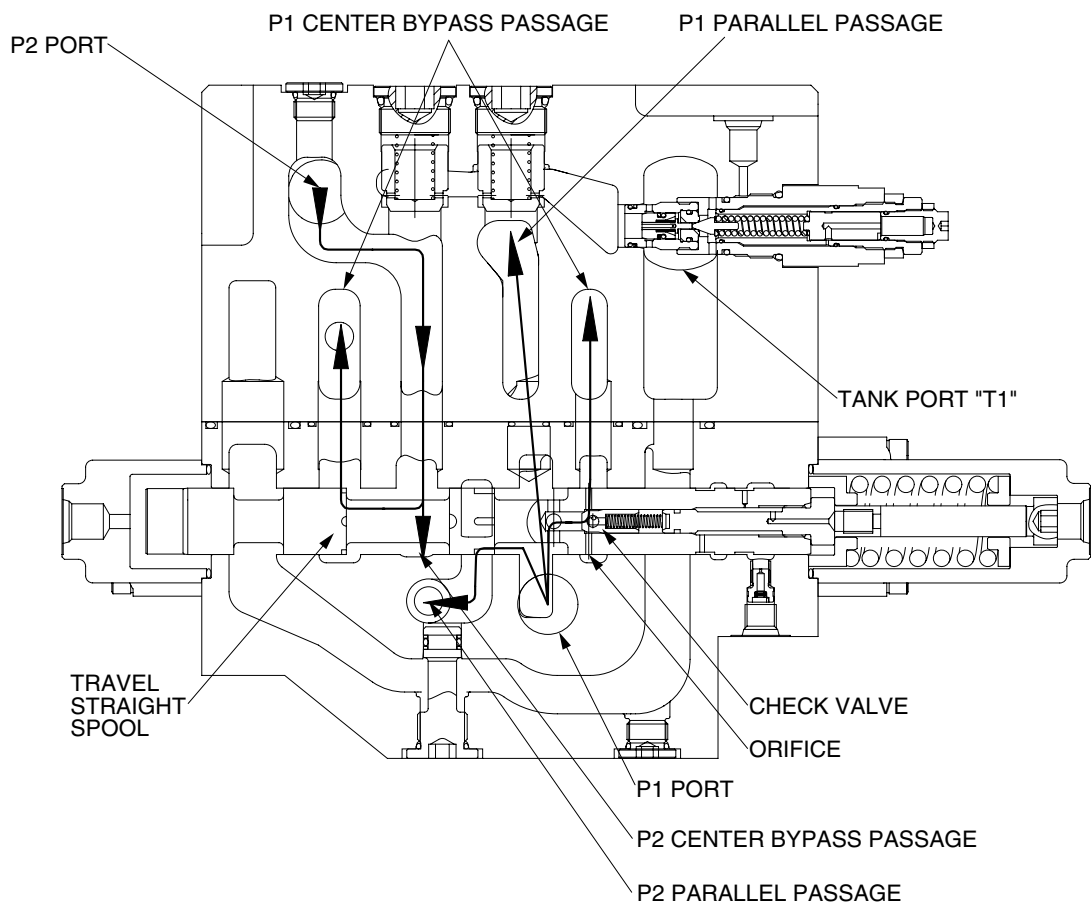

29092MC09

### 3) BOOM OPERATION

#### (1) BOOM UP OPERATION

During boom up operation, the pilot secondary pressure from RCV is supplied to the port of the spring side and shifts the boom 1 spool in the left direction. The bypass passage is shut off by the movement of the spool and the hydraulic oil fluid from pump P1 is entered P1 parallel passage and then passes through the load check valve, bridge passage and boom holding valve then flows into the port A2.

Following this it flows into the head side of the boom cylinder.

(In this case, the boom holding valve is free flow condition)

At the same time, the pilot pressure from RCV is supplied to the port of the spring side of boom 2 and shifts the boom 2 spool. The bypass passage is shut off by the movement of the spool and the hydraulic oil fluid from pump P2 entered boom summation passage via the P2 parallel passage, the land of the swing priority spool, notch of the boom 2 spool, arm 2 spool and the check. The flows combine in passage and are directed to port A2 and head side of boom cylinder. At the same time, the flow from rod side of the boom cylinder return to the boom 1 spool through the port B2. There after it is directed to the hydraulic oil tank through the tank passage.

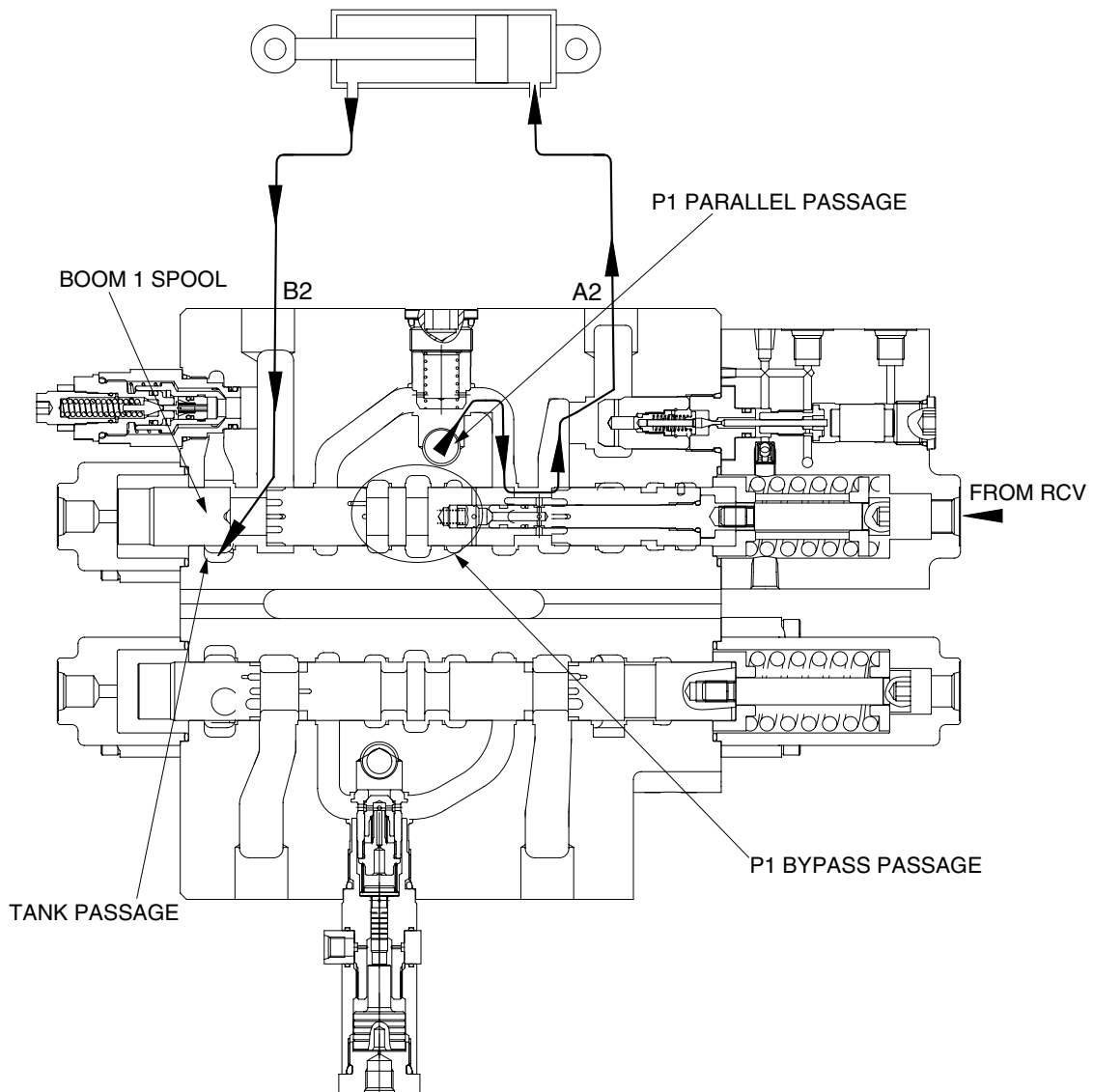

29092MC10A

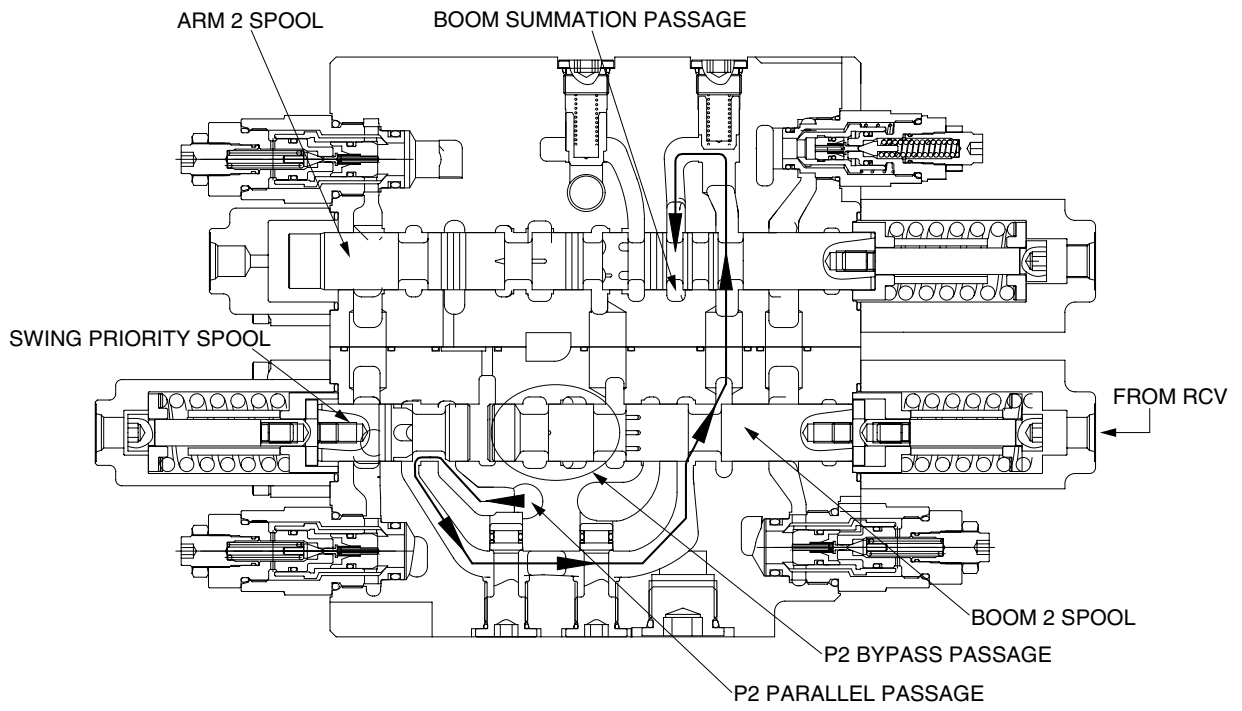

29092MC11

## (2) BOOM DOWN OPERATION

During the boom lowering operation, the pilot pressure from RCV is supplied to the port of the spring opposite side and shifts the boom 1 spool in the right direction.

The bypass passage is shut off by the movement of the spool and the hydraulic fluid from the pump P1 enters the parallel passage and is directed to the port B2 through the load check valve. Following this, it flows into the rod side of the boom cylinder.

At the same time, the return flow from the head side of the boom cylinder returns to the port A2 and boom holding valve. And it is directed to the hydraulic oil tank through opened tank passage by movement of the boom 1 spool.

Meanwhile some of return flow is directed to P1 parallel passage through the internal passage of the boom 1 spool. (boom regeneration)

In this case, the holding valve is open condition, for details of the boom holding valve, see page following page.

During the boom lowering operation, the fluid from P2 pump is not summation.

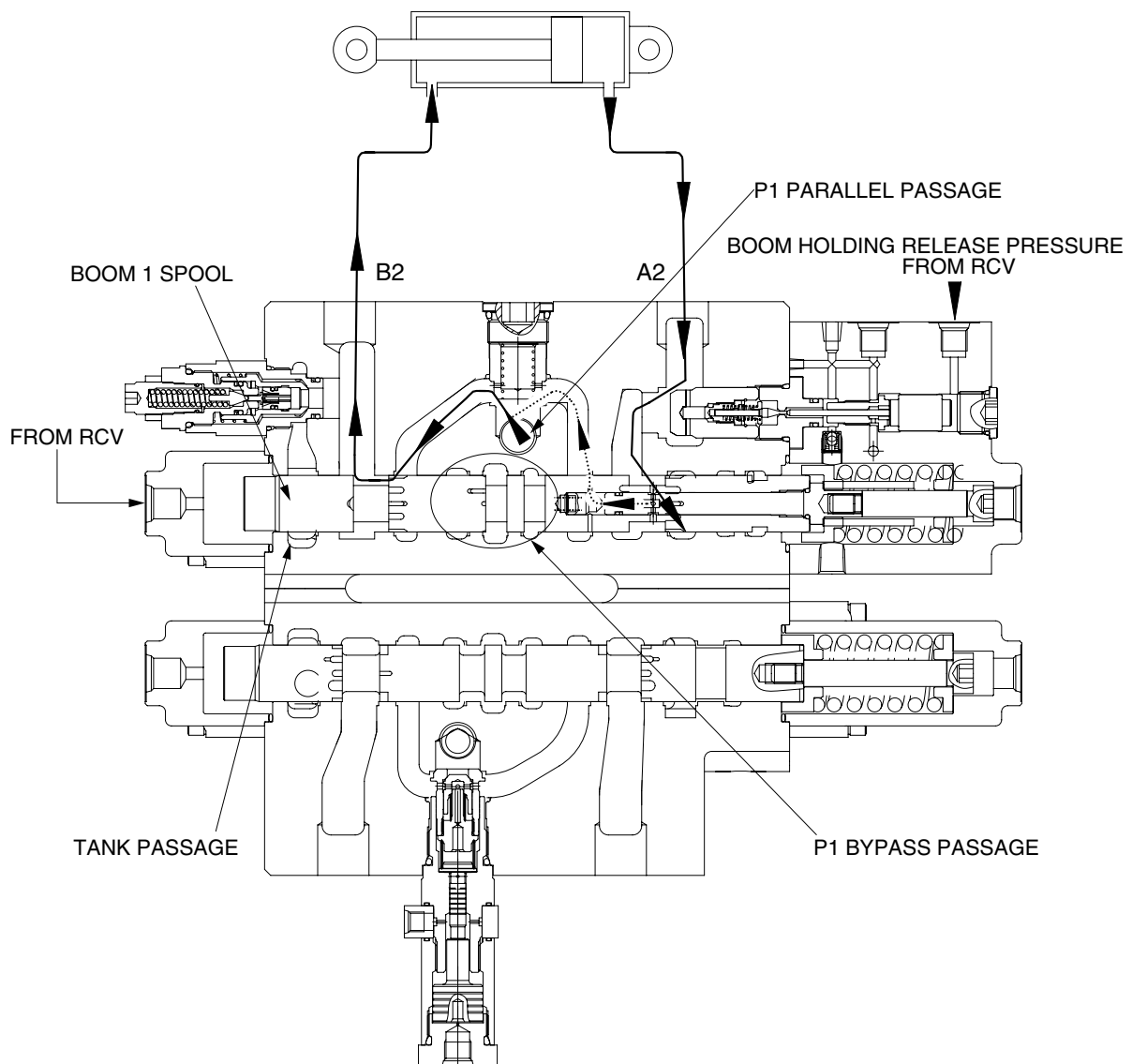

29092MC12

**4) HOLDING VALVE OPERATION**

**(1) HOLDING OPERATION**

At neutral condition, the pilot piston chamber is connected to drain port through the pilot port.

And the piston "B" is supported with spring "B".

Also, the pressured fluid from actuator entered to inside of the holding valve through the periphery hole of check, crevice of the check and the plug and the periphery hole of plug.

Then, this pressured oil pushed the poppet to the poppet seat and the check to the seat of body.

So the hydraulic fluid from actuator is not escaped and the actuator is not moved.

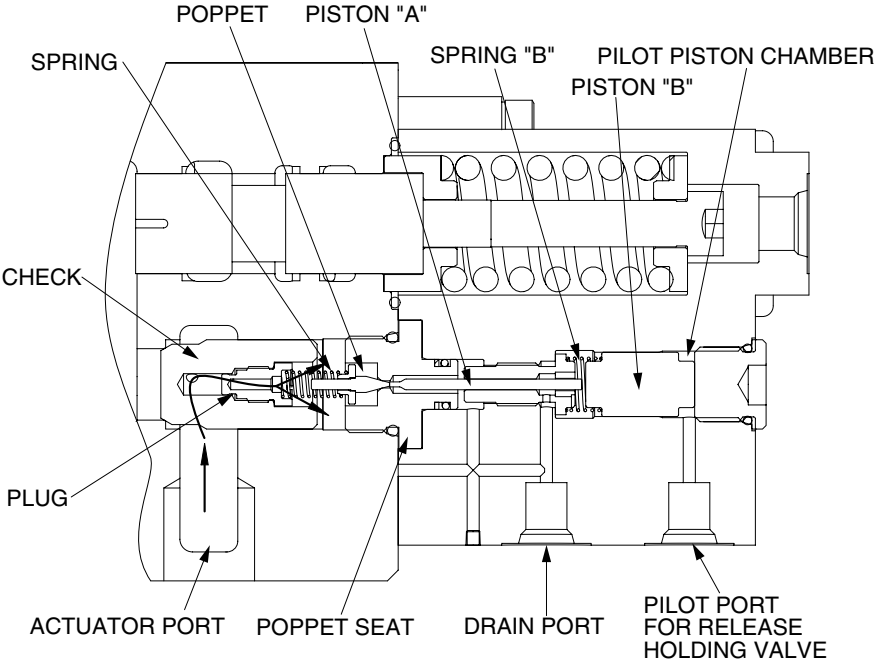

29092MC13

## (2) RELEASE HOLDING OPERATION

The pilot pressure is supplied to the pilot port for release holding valve and shifts the piston "B" in the left direction against the spring "B", and shifts the poppet in the left direction through piston "B" and piston "A" against spring "B" and shifts the spool in the left side.

At same time, the return fluid from actuator returns to the drain port through the periphery hole of check, crevice of the check and the plug, the periphery hole of the plug, in side of holding valve, crevice of the poppet and the poppet seat, the periphery hole of the poppet seat, crevice of socket and spool and internal passage of spool.

When the poppet is opened, pressure of inside of holding valve is decreased and the return fluid from actuator returns to the tank passage through the notch of spool.

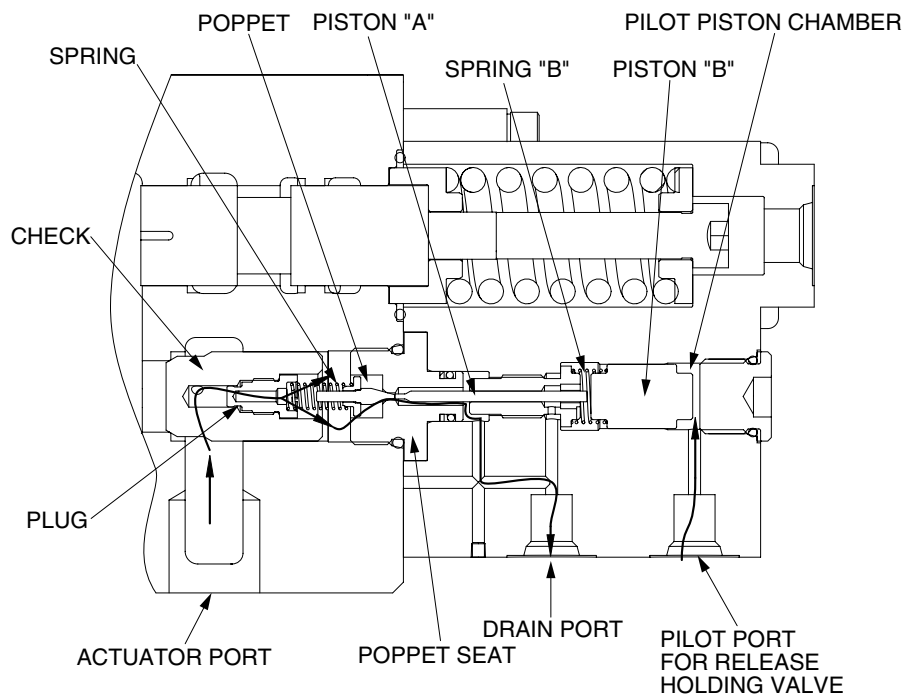

29092MC14

## 5) BUCKET OPERATION

### (1) BUCKET IN OPERATION

#### ① Bucket operation only

During the bucket in operation, the pilot secondary pressure from RCV is supplied to port of the spring side and shifts the bucket spool in the left direction.

The bypass passage is shut off by the movement of the spool and the hydraulic fluid from pump P1 entered P1 parallel passage and is directed to the port A5 through the check2.

At the same time, the hydraulic fluid from P1 bypass passage is directed to the port A5 through the check1.

Following this it flows into the head side of the bucket cylinder.

The return flow from the rod side of the bucket cylinder returns to the bucket spool through the port B5. Thereafter it is directed to the hydraulic oil tank through the tank passage.

#### ② Bucket operation with arm or boom operation

When combined operation, mostly same as above but the fluid from bypass passage is empty.

So only the fluid from parallel passage is supplied to the bucket cylinder. Also, parallel passage is installed the orifice for supplying the fluid from pump to the boom or the arm operation prior to the bucket operation.

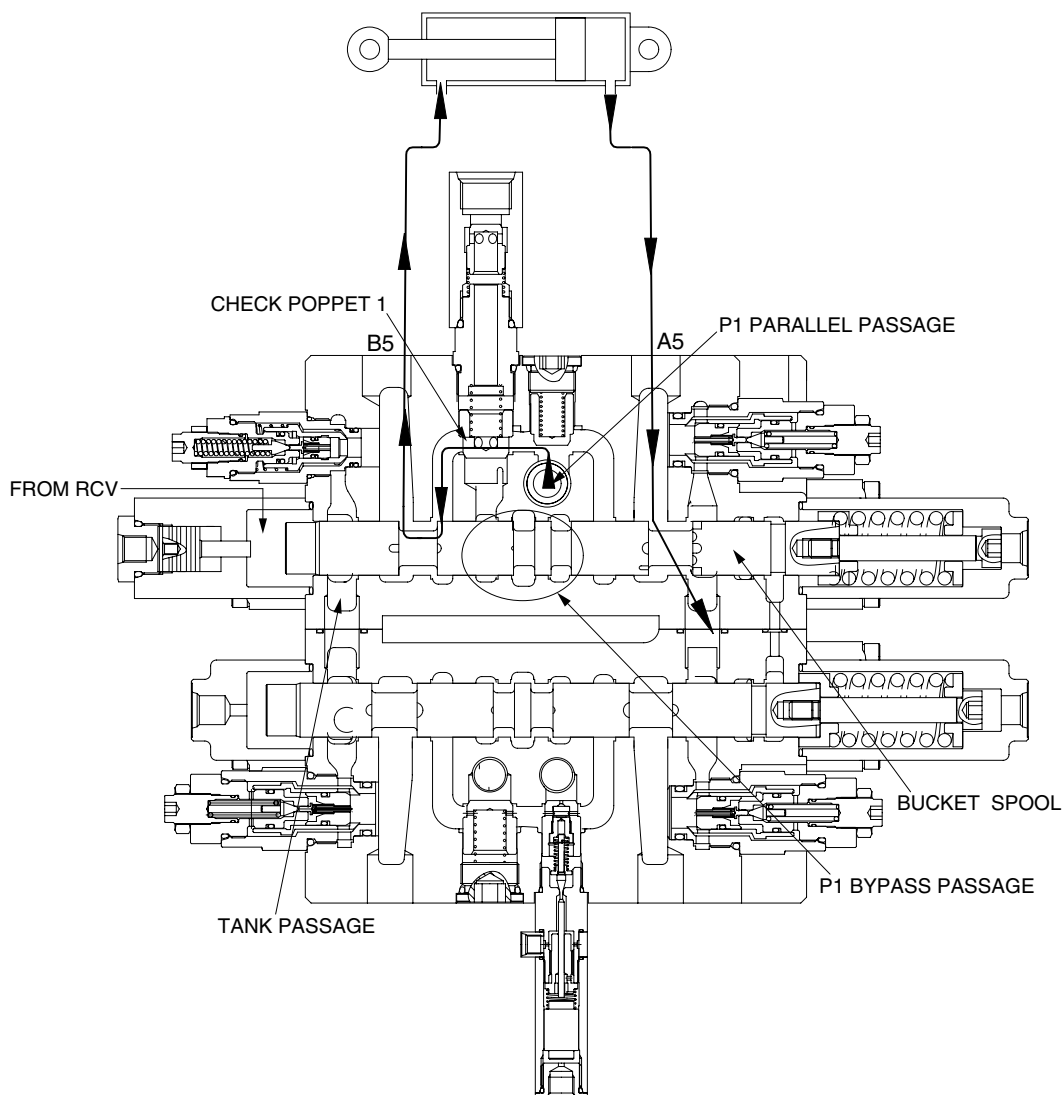

300H2MC16

## (2) BUCKET OUT OPERATION

### ① Bucket operation only

During the bucket out operation, the pilot secondary pressure from RCV is supplied to port of the spring opposite side and shifts the bucket spool in the left direction.

The bypass passage is shut off by the movement of the spool and the hydraulic fluid from pump P1 entered P1 parallel passage and is directed to the port B5 through the check1.

The return flow from the rod side of the bucket cylinder returns to the hydraulic oil tank through the tank passage and the port A5.

### ② Bucket operation with arm or boom operation

When combined operation, the same as above.

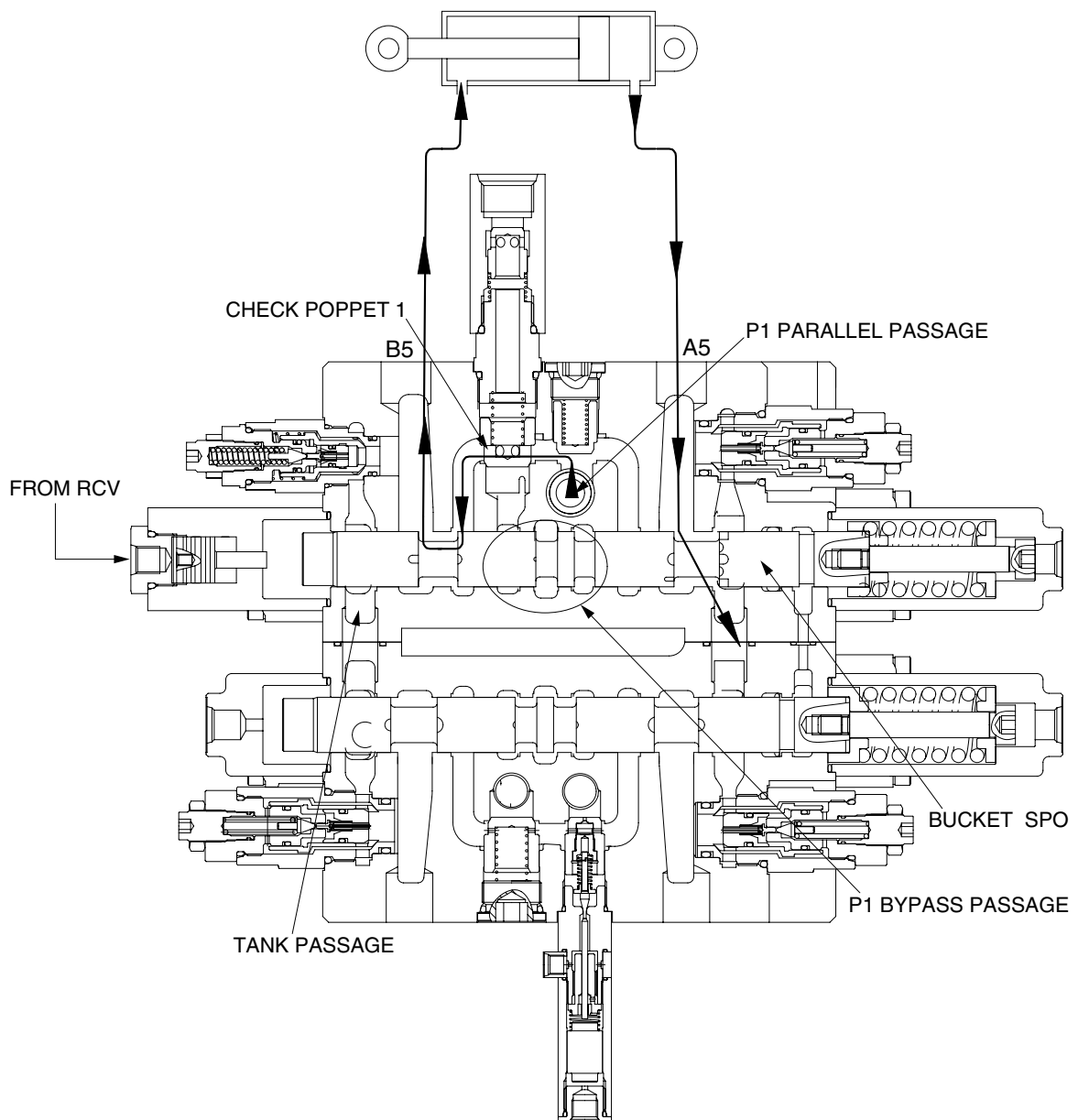

29092MC16

### (3) BUCKET SLOW OPERATION

This function is used to speed up of the boom by reducing the bucket speed when bucket operation with boom operation simultaneously.

When the boom up operation, the boom up pilot pressure is supplied the pilot port of bucket spool stroke limit and the piston is shifted to the right and then the bucket spool stroke is limited and the open of the bucket spool is reduced.

Accordingly, the oil of the bucket spool is reduced and the boom speed up.

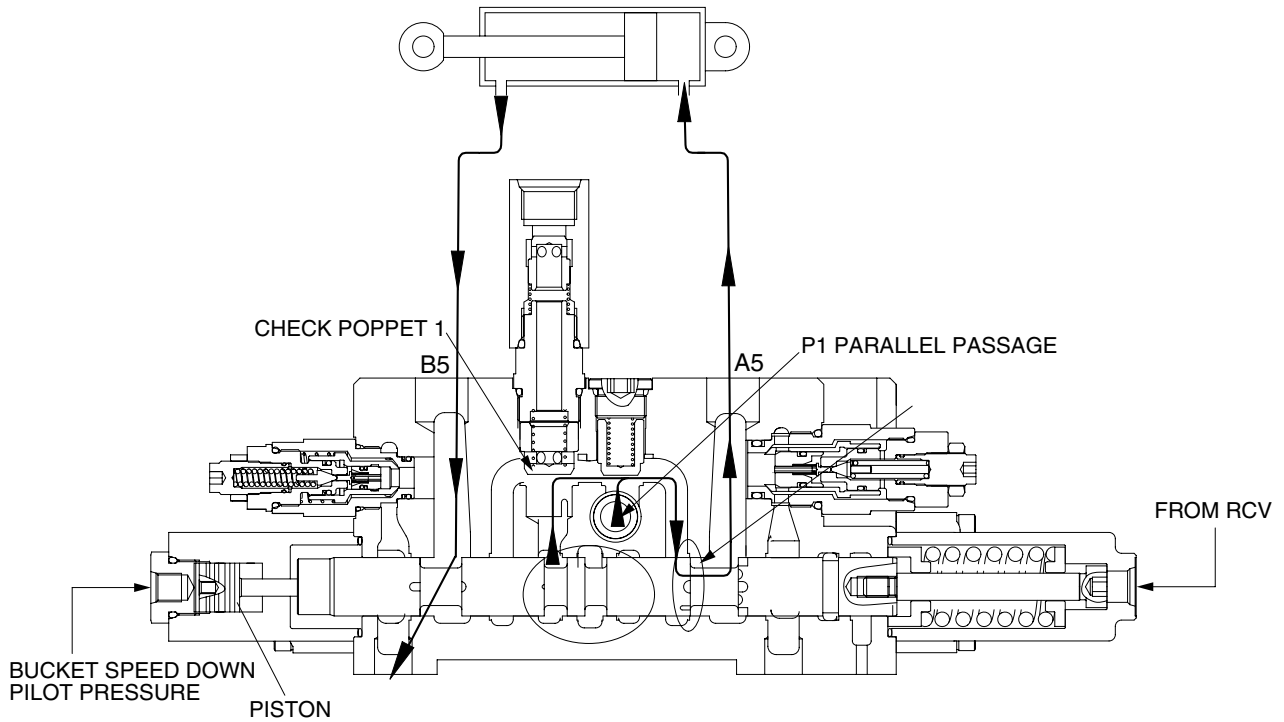

300H2MC17

## 6) SWING OPERATION

### (1) SWING LEFT & RIGHT OPERATION

During the swing left operation, the pilot secondary pressure from the RCV is supplied to the port of the spring side and shift the swing spool in left direction. The bypass passage is shut off by the movement of the spool and the hydraulic fluid from pump P2 flows into swing spool through the parallel passage. Then it is directed to swing motor through the port D2.

As the result, swing motor turns and flow from the swing motor returns to the hydraulic oil tank through the port C2, swing spool and the tank passage.

In case of swing right operation, the operation is similar to swing left operation but the pilot secondary pressure from the RCV is supplied to the port of the spring opposite side.

Accordingly, the hydraulic fluid from pump P2 flows into swing motor through the port C2 and returns to the hydraulic oil tank through the port D2 and the tank passage.

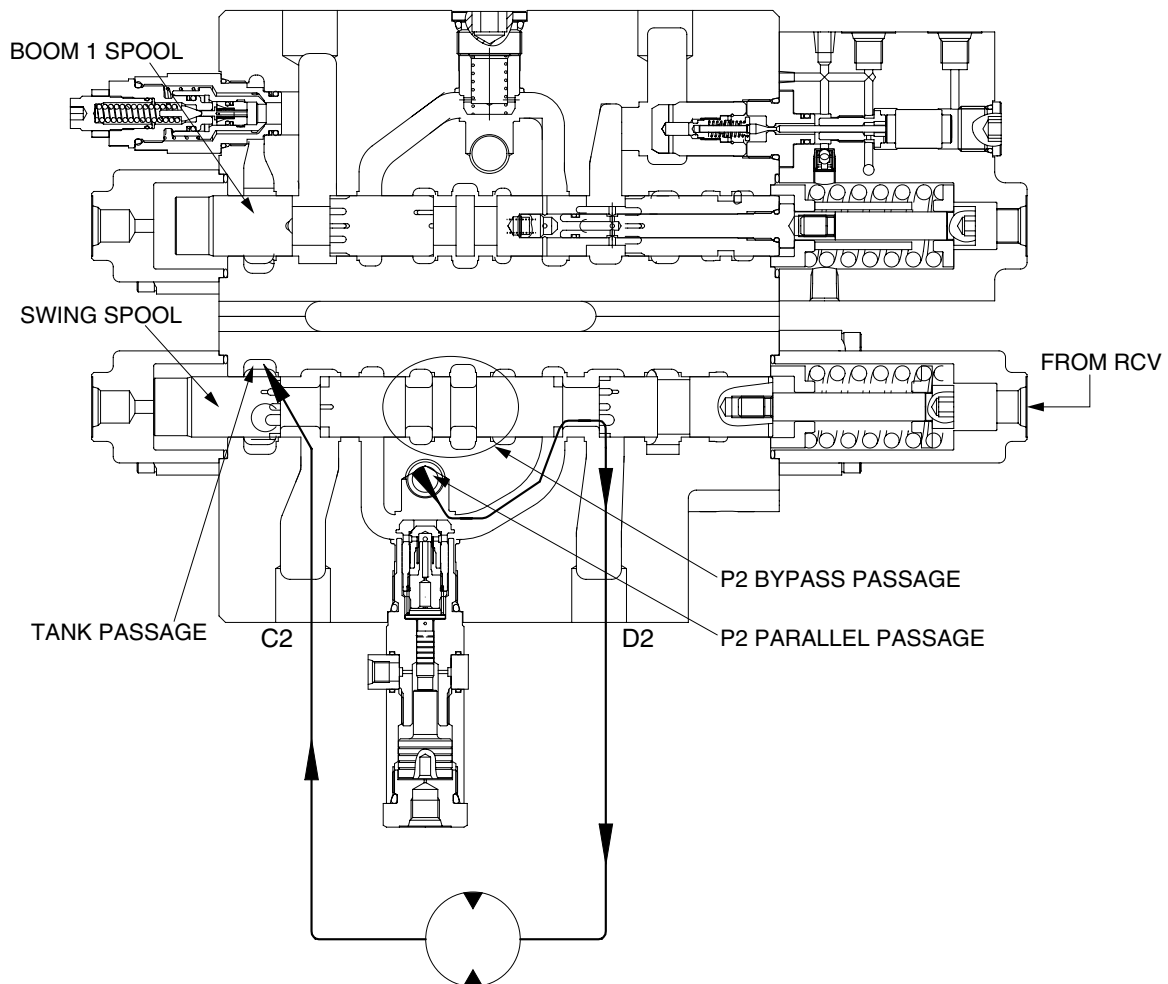

29092MC18

## (2) SWING SLOW DOWN OPERATION

This operation is used to speed up the boom or arm by reducing the swing speed when swing operation with boom or arm operation.

The poppet of swing logic valve is closed by the pilot pressure of swing speed down is supplied to the port, the fluid from the port P2 is drained through orifice. Accordingly, the fluid from the port P2 is reduced and swing speed is slow down.

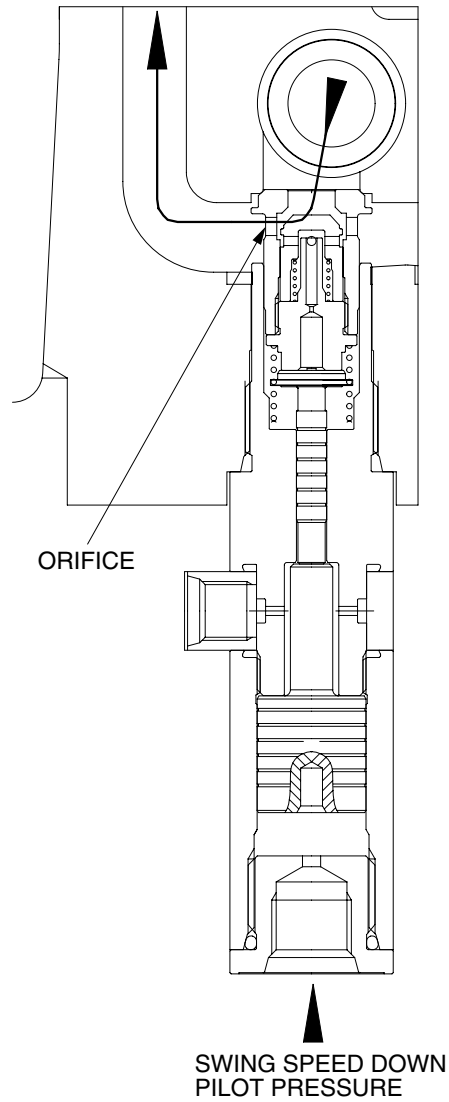

29092MC19

## 7) ARM OPERATION

### (1) ARM IN OPERATION

During arm in operation, the pilot secondary pressure from the RCV is supplied to the port of spring opposite side and shifts arm 1 spool in the right direction.

The bypass passage is shut off by the movement of the arm 1 spool and the hydraulic oil from the pump P2 flows into the arm cylinder head side through P2 parallel passage, the load check valve, bridge passage and the port C4.

At same time, the pilot secondary pressure from the RCV is supplied to the port of spring opposite side and shifts arm 2 spool in the right direction. The bypass passage is shut off by the movement of the spool and the hydraulic fluid from the pump P1 flows into the arm summation passage through parallel passage, the check valve, the arm 2 spool and the boom 2 spool. Then it entered the arm cylinder head side with hydraulic fluid from arm 1 spool.

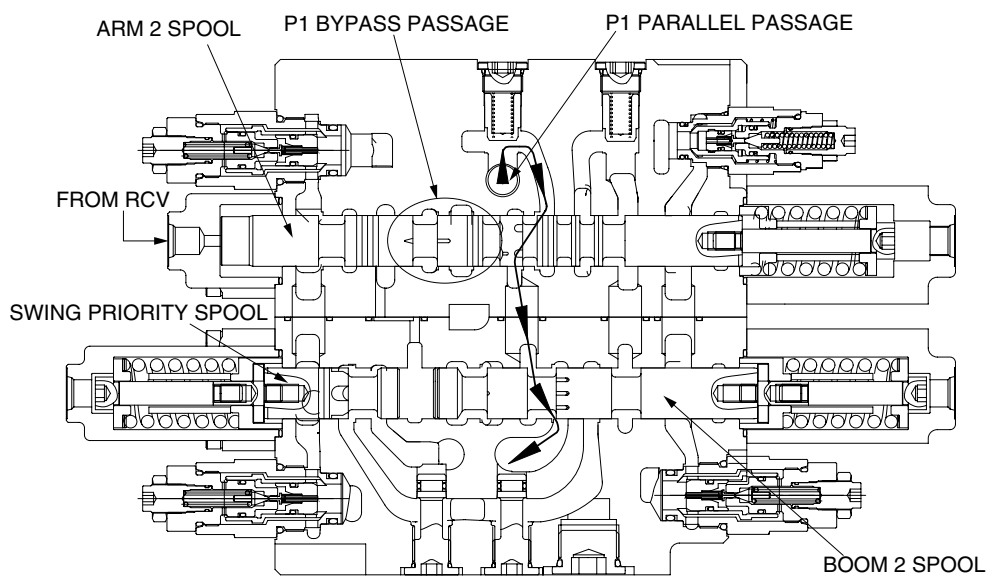

29092MC20

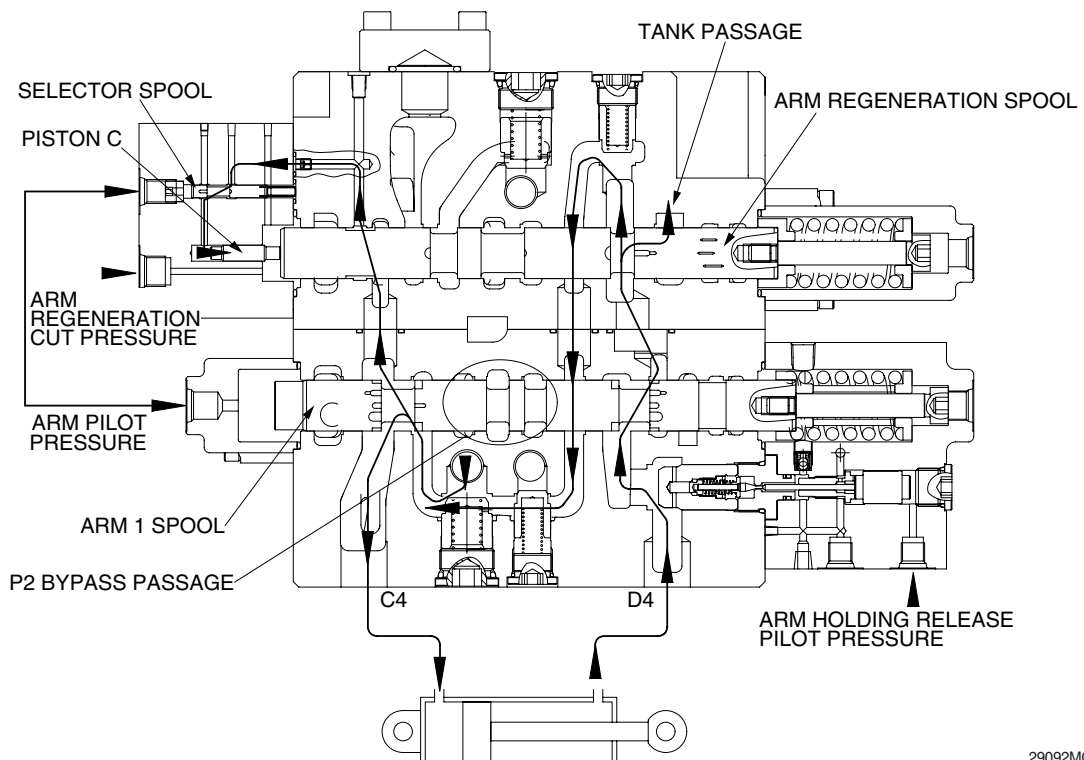

29092MC21

## ARM REGENERATION

The return flow from the arm cylinder rod side is pressurized by self weight of arm and so, returns to port D4. The pressurized oil returning to port D4 enters the arm regeneration spool through the arm holding valve and the arm 1 spool. It is supplied the arm cylinder head through internal passage. This is called the arm regeneration function.

The amount of regeneration fluid is changed by movement of the arm regeneration spool. A few fluids after P2 parallel passage is push piston "C" through the notch of arm regeneration spool and selector spool. At this time, the selector spool is opened by pilot pressure from RCV.

Then, the arm regeneration spool shifts to right side and flow to tank pass increases and regeneration flow decreases. Therefore, pressure of arm cylinder head increases, then, arm regeneration flow decreases.

Furthermore, the arm regeneration cut pressure is supplied to the port of spring opposite side and arm regeneration spool is move into the right direction fully. The flow from the arm cylinder rod is returned to the hydraulic oil tank and regeneration function is not activated. (The return fluid is maximum condition)

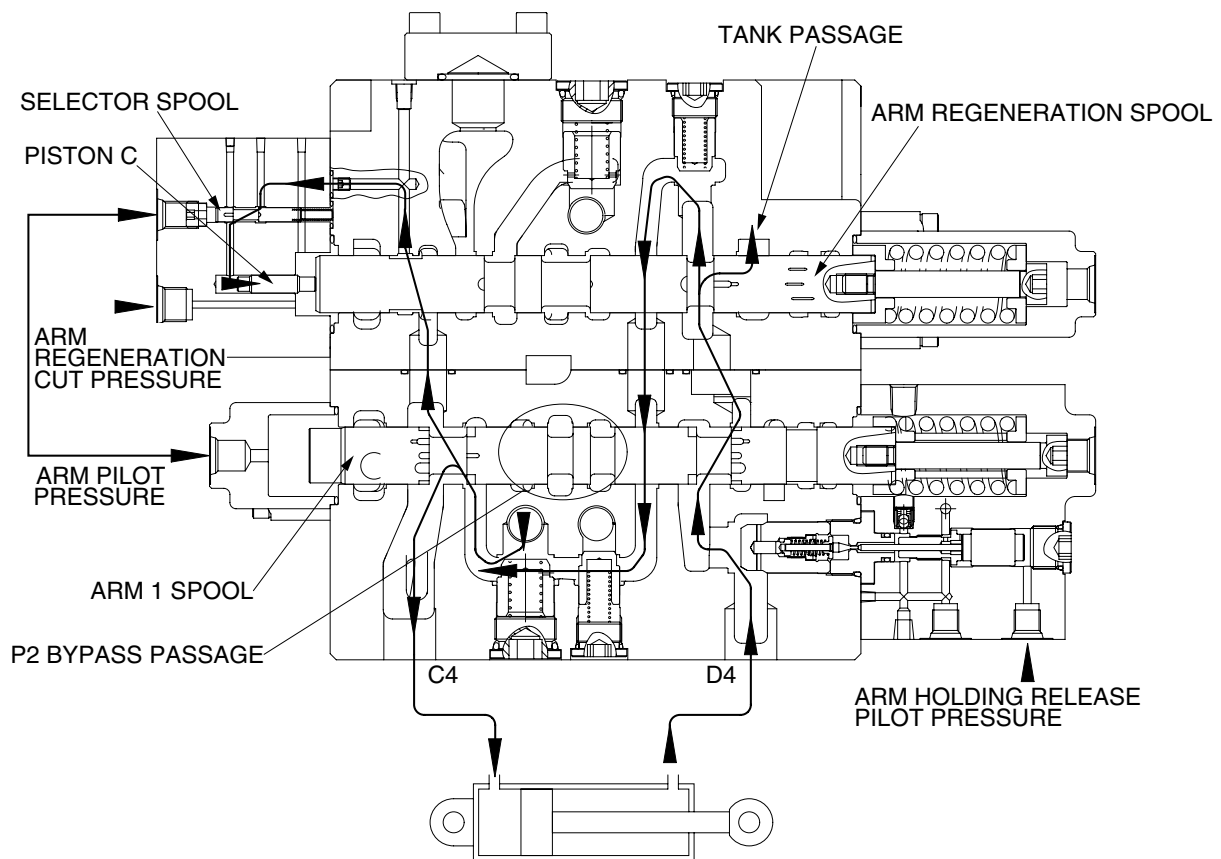

29092MC21

## (2) ARM OUT OPERATION

During arm out operation, the pilot secondary pressure from RCV is supplied to the port of spring side and shifts arm 1 spool in the left direction.

The bypass passage is shut off by the movement of the spool and the hydraulic fluid from pump P2 flows into arm 1 spool through the parallel passage. Then it enters into the arm cylinder rod side through the load check valve, bridge passage, arm holding valve and the port D4.

Also, the pilot secondary pressure from RCV is supplied to the port of spring side and shifts arm 2 spool in the left direction.

The bypass passage is shut off by the movement of the spool and some of the hydraulic fluid from pump P2 bypassed through bypass notch. The rest of hydraulic fluid from pump P2 flows into the arm summation passage through P1 parallel passage the check valve arm 2 spool and boom 2 spool.

Then it enters into the arm cylinder rod side with the fluid from the arm 1 spool.

The return flow from the arm cylinder head side returns to the hydraulic tank through the port C4 the arm 1 spool and tank passage.

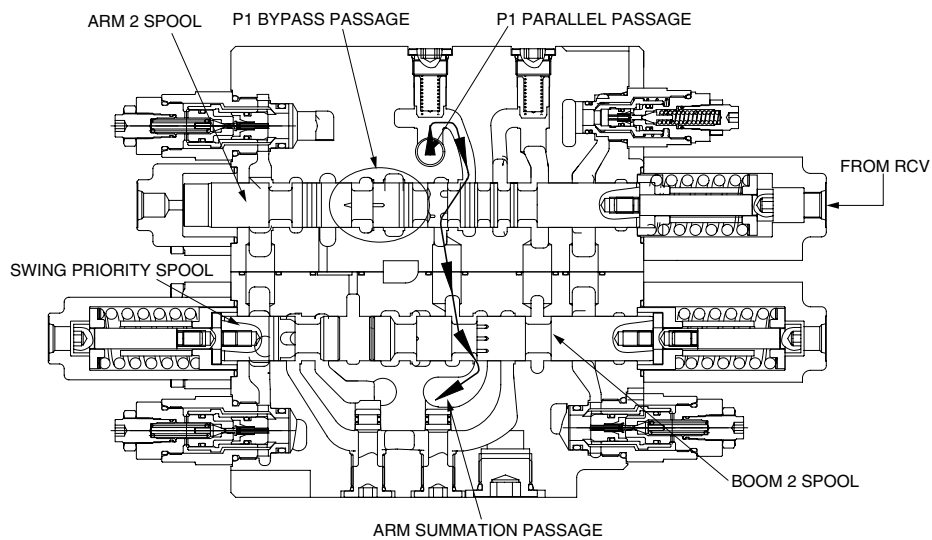

29092MC22

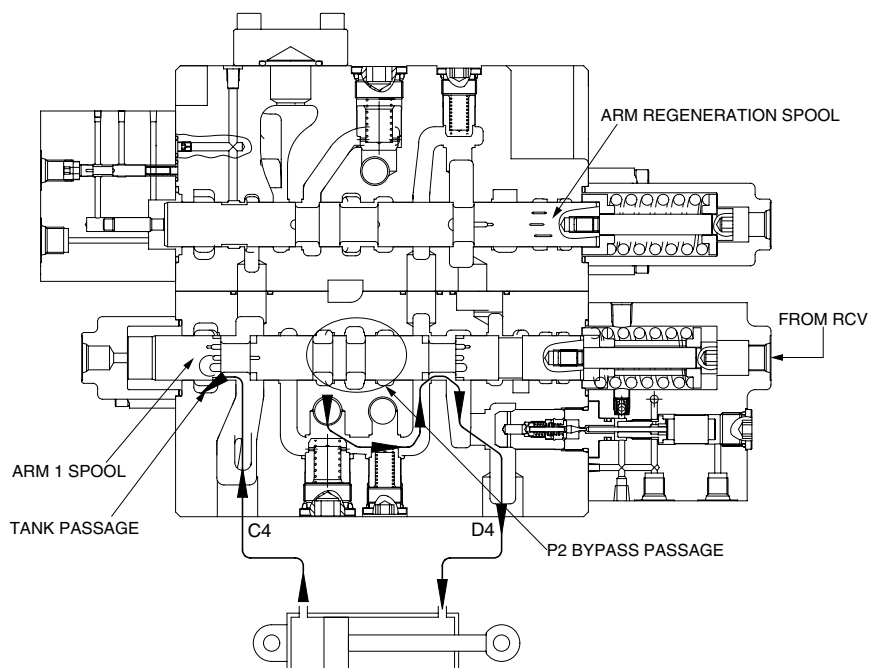

29092MC23

## 8) SWING PRIORITY FUNCTION

During swing priority operation, the pilot secondary pressure is supplied to the port of the spring side of the swing priority spool and shift swing priority spool in the right direction.

The hydraulic fluid from P2 parallel passage flows into the parallel passage of arm 1 side through swing priority spool and the passage "A" and also flows into the boom 2 spool.

When the swing priority spool is neutral condition, the passage is same as normal condition. But due to shifting of the swing priority spool, the fluid from pump P2 flows to swing side more then the boom 2, arm 1, option B and bucket summation spools to make the swing operation most preferential.

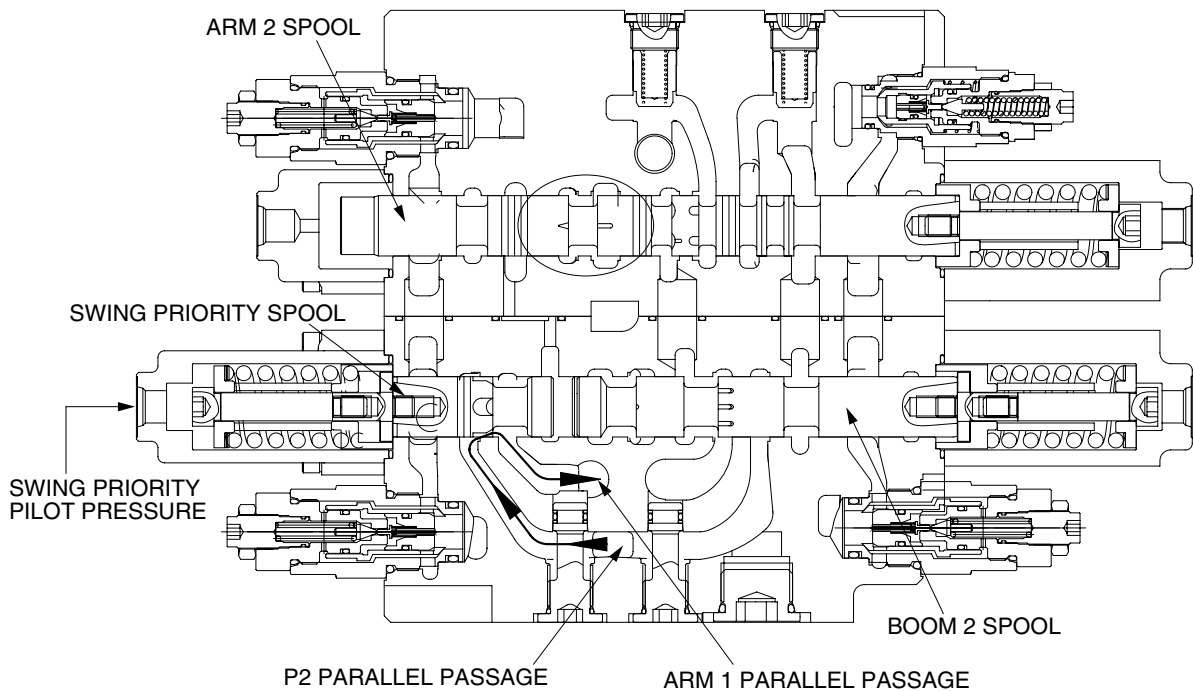

29092MC24

## 9) OPERATION OF OPTION

### (1) OPERATION BY PUMP P2

The pilot secondary pressure from RCV is supplied to the port of spring side and shifts option spool as the figure.

The bypass passage is shut off by the movement of the spool and the hydraulic fluid from pump P2 flows into actuator through the load check valve, bridge passage and port D5.

If the pilot pressure is not supplied to P1 summation pilot port and is not shifts arm 2 spool. Accordingly, the pump P1 fluid connected the parallel passage is not flowing the check poppet of option ON/OFF valve and the fluid from pump is not joined the fluid from P2.

At the same time, the fluid from actuator returns to the tank passage through port C5 and notch of the option spool.

In case of reverse operation, the operating principle is same as above.

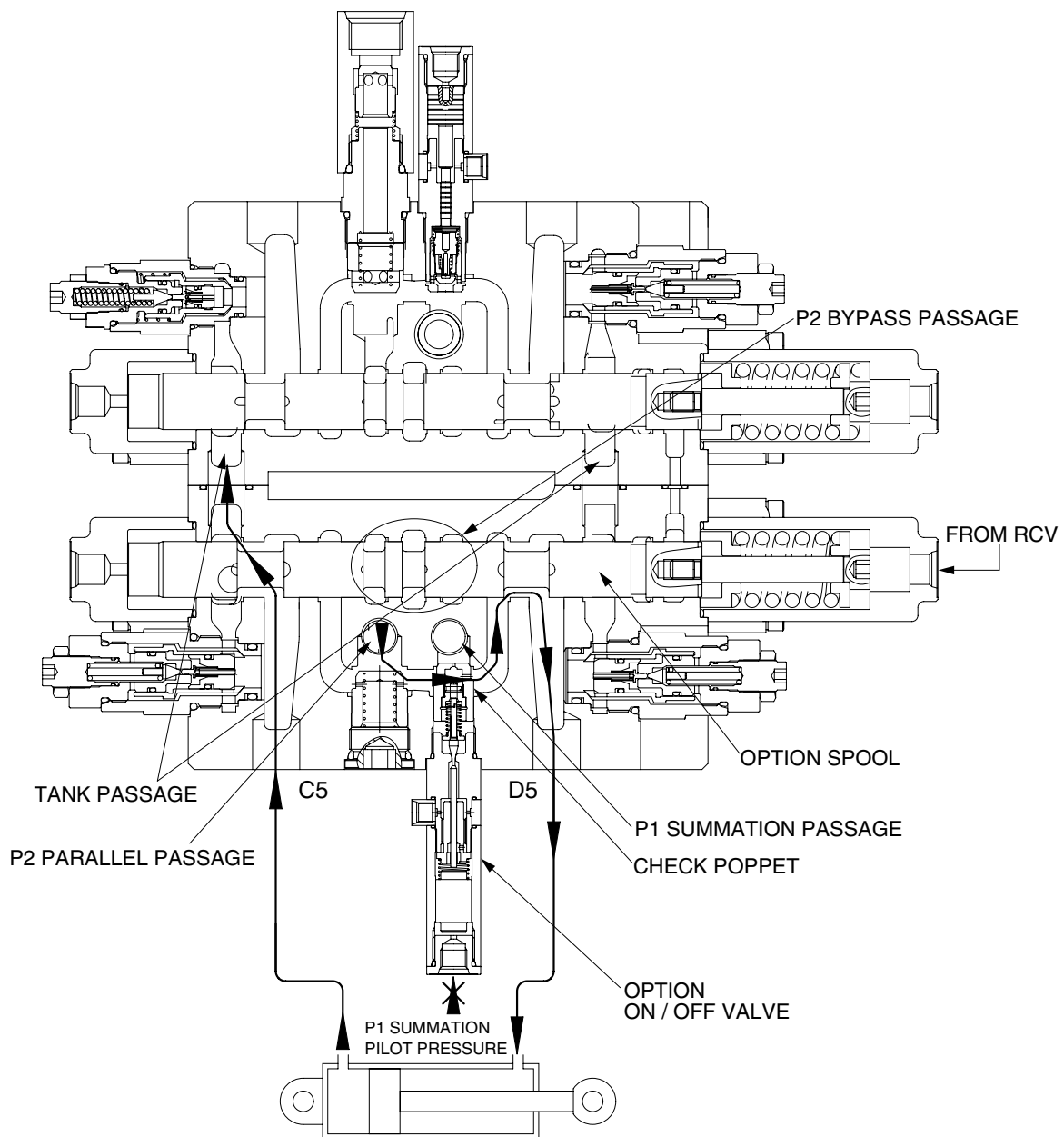

## (2) SUMMATION OPERATION WITH PUMP P1

The pilot pressure from RCV is supplied to option pilot port and one of arm 2 pilot port at the same time, the fluid for the arm summation is build up. This fluid flows into the arm 1 spool priority but the arm is not operated, the fluid flows into P1 summation passage. Now the pilot pressure of RCV is supplied to the P1 summation pilot port of option ON/OFF valve, the fluid from pump P1 opens the load check valve and flows into port D5 with the fluid of pump P2.

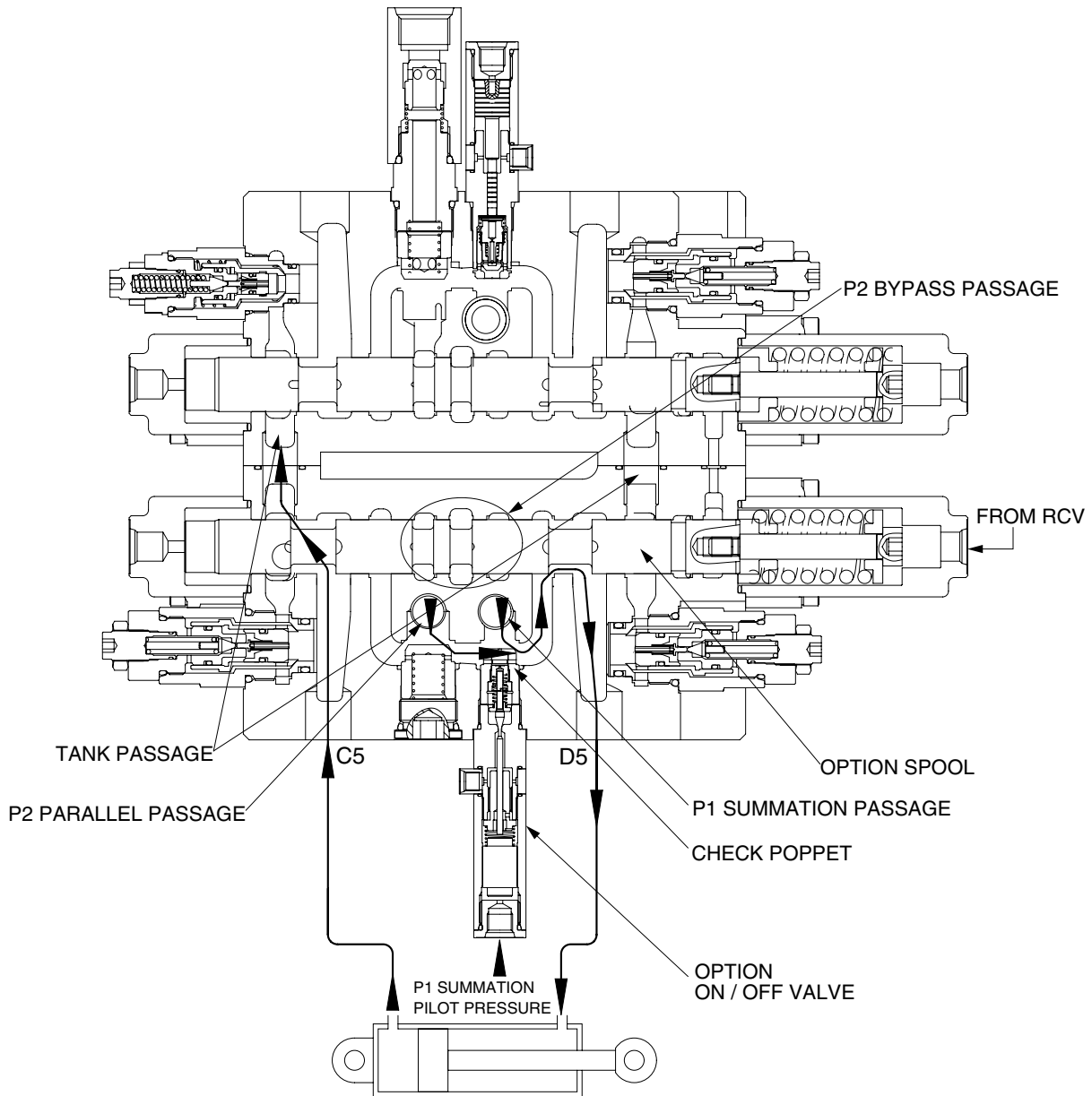

29092MC27

## 11) NEGATIVE RELIEF VALVE OPERATION

When no function is being actuated on P1 side, the hydraulic fluid from the pump P1, flows into the tank passage through the bypass passage and orifice. The restriction caused by this orifice thereby pressurizes. This pressure is transferred as the negative control signal pressure Pn1 to the pump P1 regulator.

It controls the pump regulator so as to minimize the discharge of the pump P1.

The bypass passage is shut off when the shifting of one or more spools and the flow through bypass passage became zero. The pressure of negative control signal becomes zero and the discharge of the pump P1 becomes maximum.

The negative control pressure reaches to the set level, the hydraulic fluid in the passage pushes open negative control valve and escapes into the return passage.

For the pump P2 the same negative control principle.

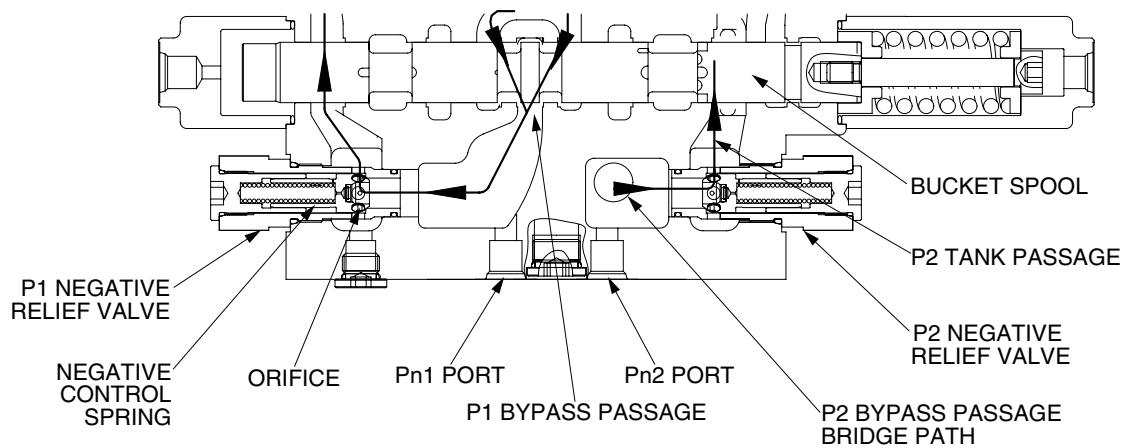

29092MC28

## 12) OPERATION OF MAIN RELIEF VALVE

- (1) The pressurized oil passes through the orifice (A) of the plunger is filled up in chamber A of the inside space, and seats the plunger against the housing securely.

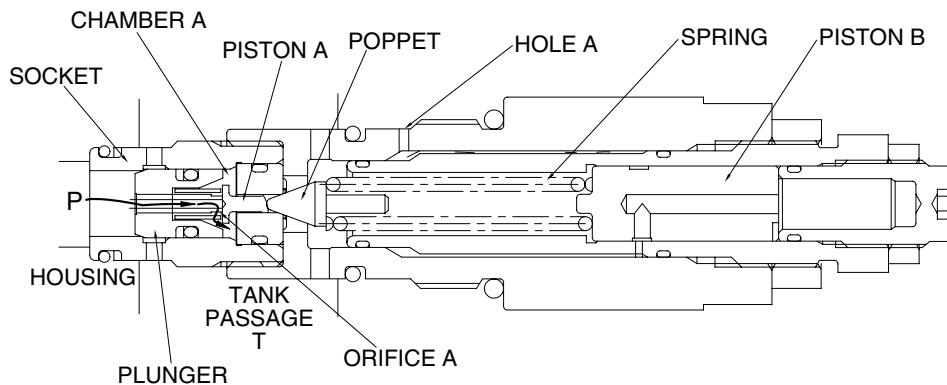

29092MC29

- (2) When the pressure at (P) becomes equal to the set pressure of the spring the hydraulic oil passes through the piston (A) pushes open the poppet and flows to tank passage (T) through the plunger internal passage, periphery orifice A, chamber A, periphery orifice B and the hole (E).

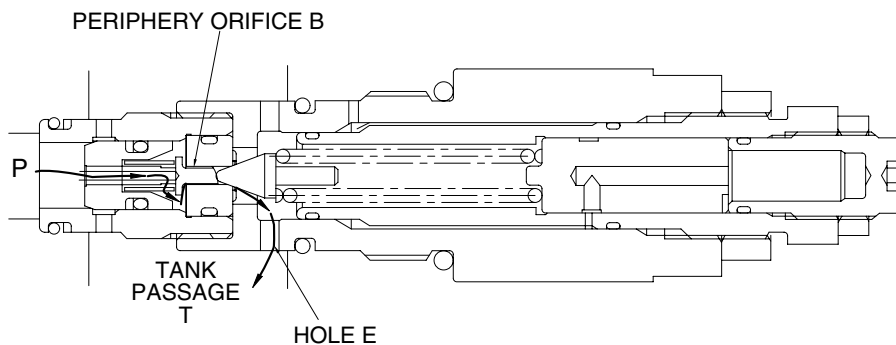

29092MC30

- (3) Opening the poppet causes the pressure in chamber A to fall and the plunger to open. As the result the pressurized oil at port P runs into tank passage (T).

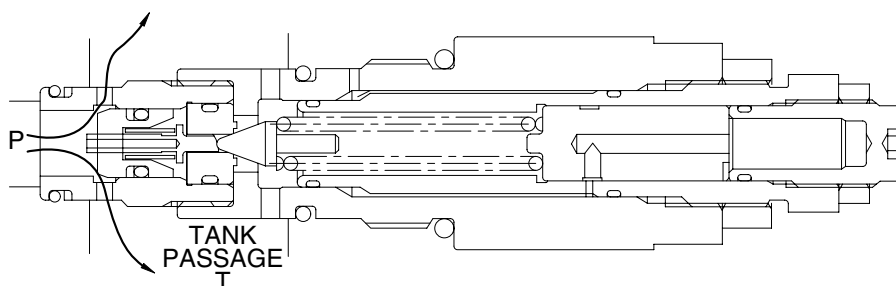

29092MC31

- (4) The pressure at port P becomes lower than set pressure of the spring, the poppet is seated by spring force. Then the pressure at port P becomes equal to set pressure of the spring and the plunger is seated to the socket.

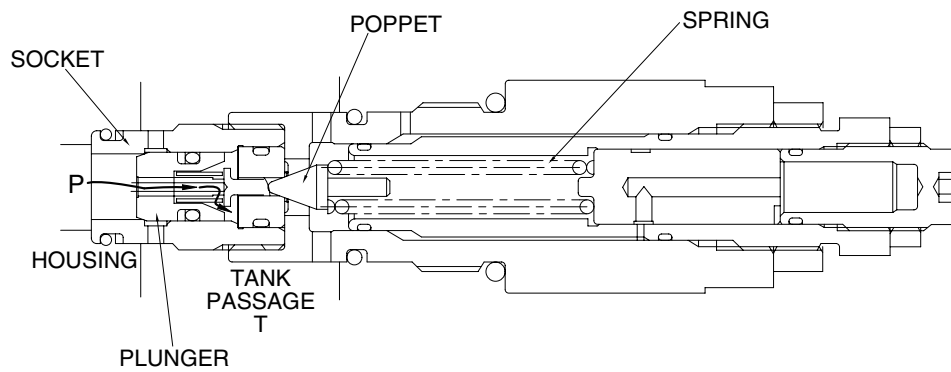

29092MC29-2

- (5) When the power boost switch is ON, the pilot pressure enters through hole A. It pushes the piston (B) in the left direction to increase the force of the spring and change the relief set pressure to the high pressure.

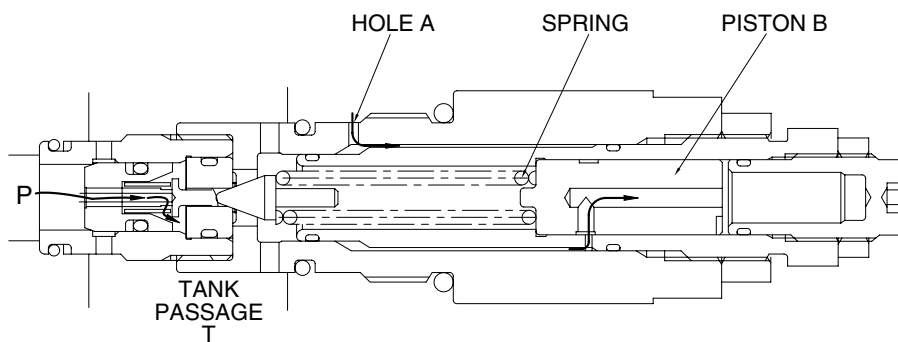

29092MC29-1

### 13) OPERATION OF OVERLOAD RELIEF VALVE

#### FUNCTION AS RELIEF VALVE

- (1) The pressurized oil passes through the piston and orifice A is filled up in chamber A of the inside space and seat the plunger against the socket and the socket against the housing securely.

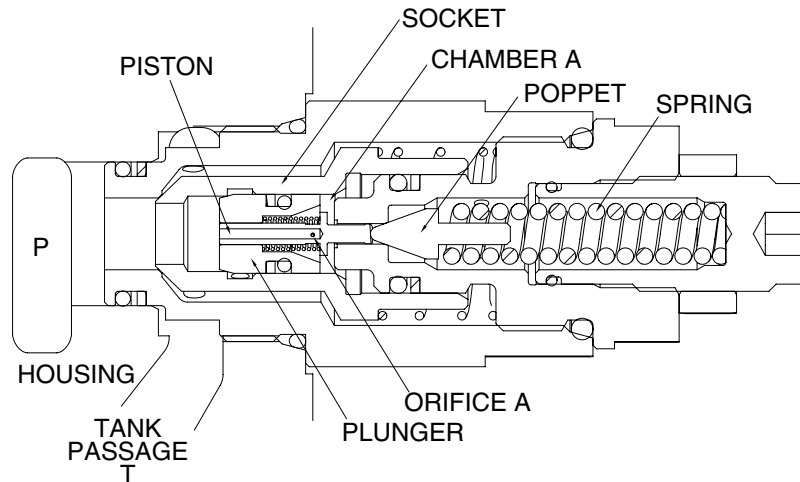

29092MC32

- (2) When the pressure at port P becomes equal to the set pressure of the spring, the pressurized oil pushes open the poppet and flows to tank passage (T) through the plunger internal passage, orifice A, chamber A, periphery orifice B and hole E.

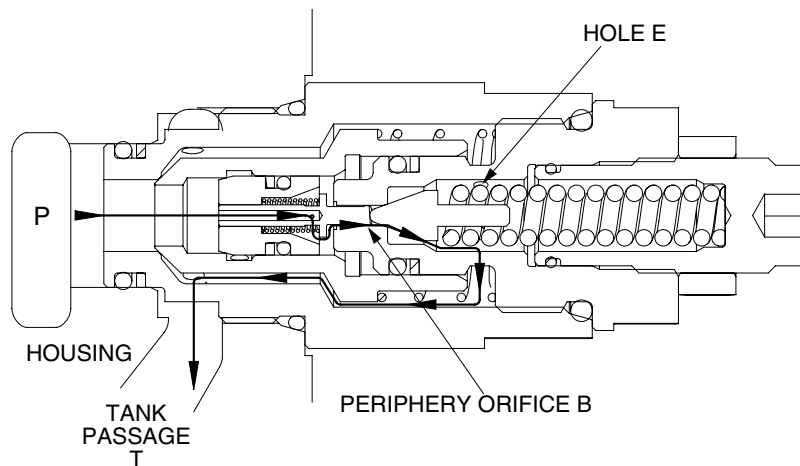

29092MC33

- (3) Opening of the poppet causes the pressure in chamber A to fall and the plunger to open. As the result the pressurized oil at port P runs into tank passage (T).

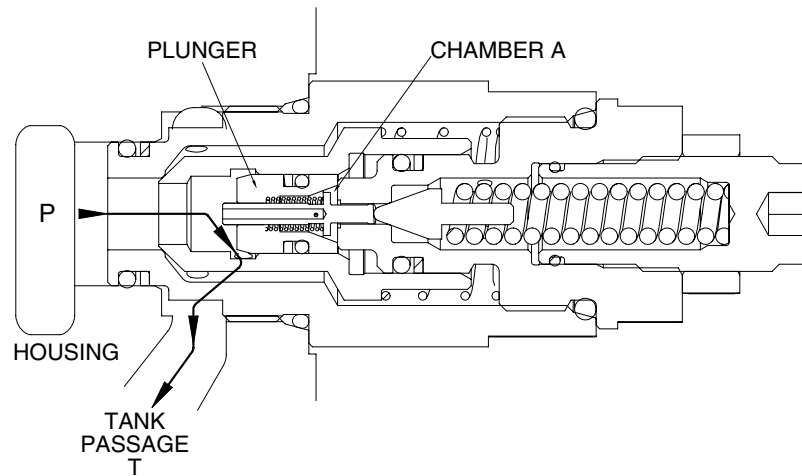

29092MC34A

- (4) The pressure at port P becomes lower than set pressure of the spring, the poppet is seated by spring force. Then the pressure at port P becomes equal to set pressure of the spring and the plunger is seated to the socket.

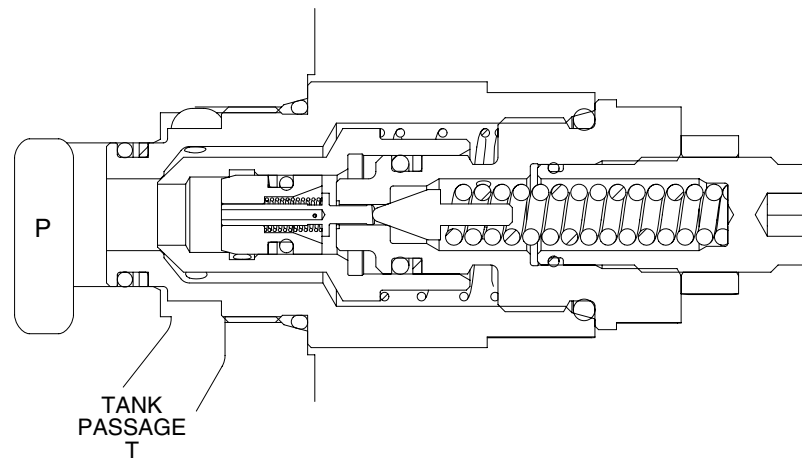

29092MC32-1

## MAKE-UP FUNCTION

- (5) When negative pressure exists at port P, the oil is supplied through tank passage (T). When the pressure at tank passage (T) becomes higher than that of at port P, the socket moves in the right direction. Then, sufficient oil passes around the socket from tank passage (T) to port P and fills up the space.

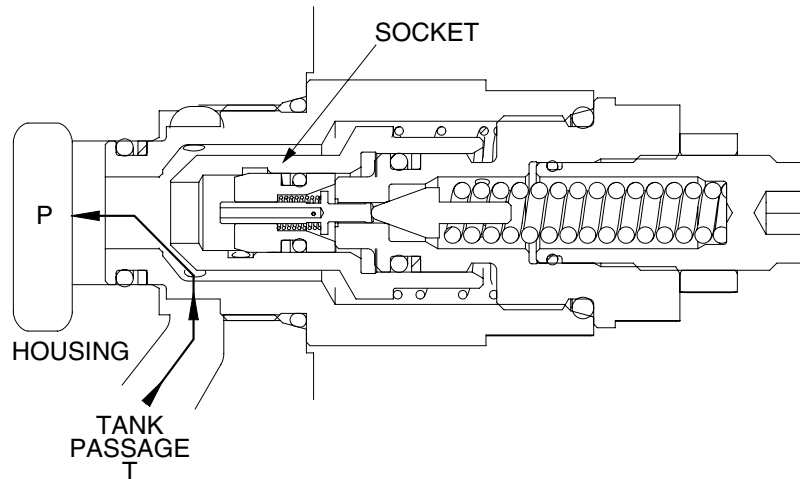

29092MC35

## 14) BREAKER OVERLOAD RELIEF VALVE FUNCTION

- (1) The structure and function of 2 stage relief valve is similar with the overload relief but it can set the higher pressure by pilot pressure.

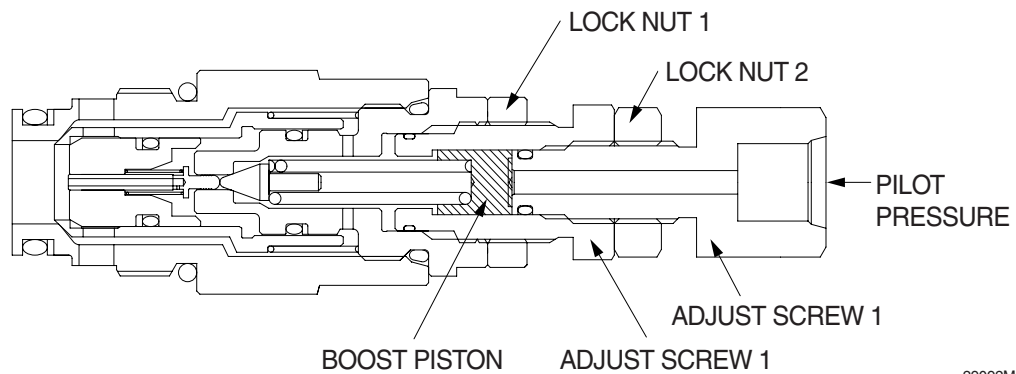

29092MC46

### Boost function

- (1) When the pilot pressure is supplied, the spring is a little compressure by moving of the boost piston and the set pressure is higher as length of spring compressed.

### Pressure set method

- (2) Loosen lock nut 1 and 2 and then full tighten adjust screw 2.
- (3) Set the high pressure by adjusting the adjust screw 1 and 2 and then fix it by the lock nut 1. Keep the adjust screw 1 do not move when fixing the lock nut 1.
- (4) Set the low pressure by adjusting the adjust screw 2 and then fix it by the lock nut 2. Keep the adjust screw 2 do not move when fixing the lock nut 2.