

GROUP 10 UNDERCARRIAGE

1. RUBBER TRACK

1) REMOVAL

- (1) Loosen tension of the rubber track.
 - ※ If track tension is not relieved when the grease valve is loosened, move the machine backwards and forwards.

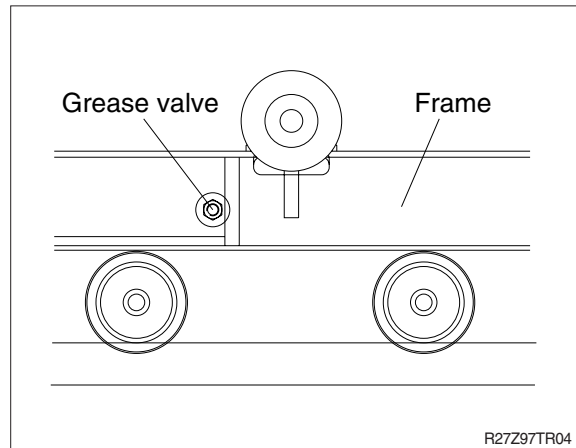

- (2) Remove the rubber track from lower frame using pry.

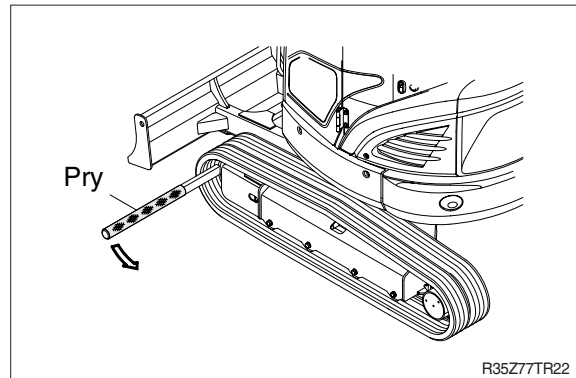

2) INSTALL

- (1) Carry out installation in the reverse order to removal.
 - ※ Adjust the tension of the rubber track.

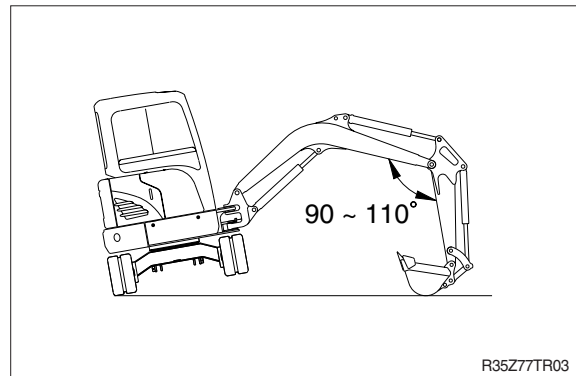

2. CARRIER ROLLER

1) REMOVAL

- (1) Loosen tension of the rubber track.

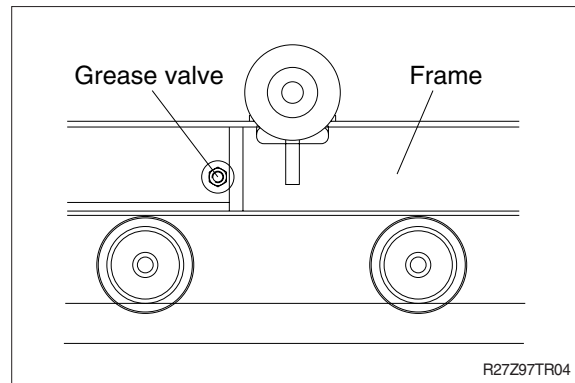

- (2) Jack up the rubber track height enough to permit carrier roller removal.

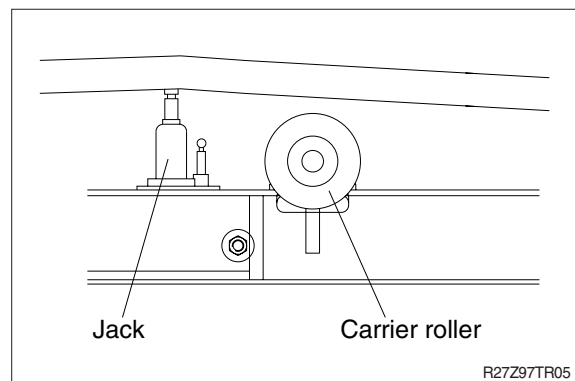

- (3) Loosen the bolt and nut (1).
 - Tightening torque : $12.3 \pm 1.2 \text{ kgf} \cdot \text{m}$
($89 \pm 8.68 \text{ lbf} \cdot \text{ft}$)
- (4) Open bracket (2) with a screwdriver, push out from inside, and remove carrier roller assembly.
 - Weight : 3 kg (7 lb)

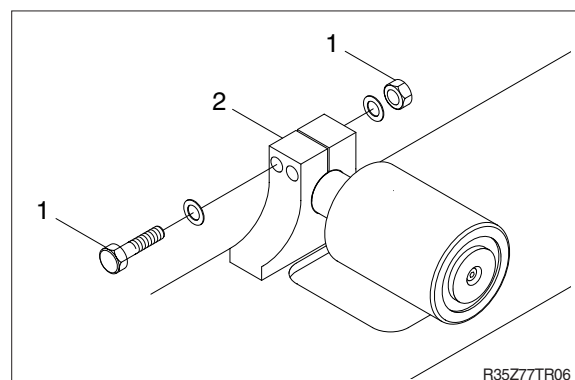

2) INSTALL

- (1) Carry out installation in the reverse order to removal.

3. TRACK ROLLER

1) REMOVAL

- (1) Loosen tension of the rubber track.

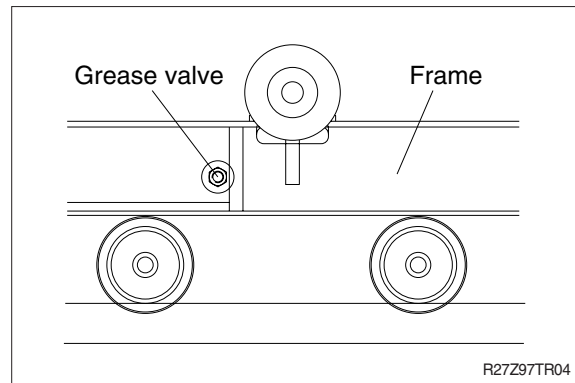

- (2) Using the work equipment, push up track frame on side which is to be removed.
※ After jack up the machine, set a block under the unit.

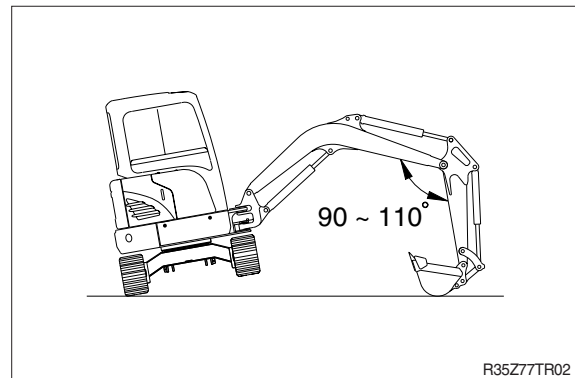

- (3) Remove the mounting bolt (1) and draw out the track roller (2).
 - Weight : 6 kg (13 lb)
 - Tightening torque : 29.7 ± 3.0 kgf · m
(215 ± 21.7 lbf · ft)

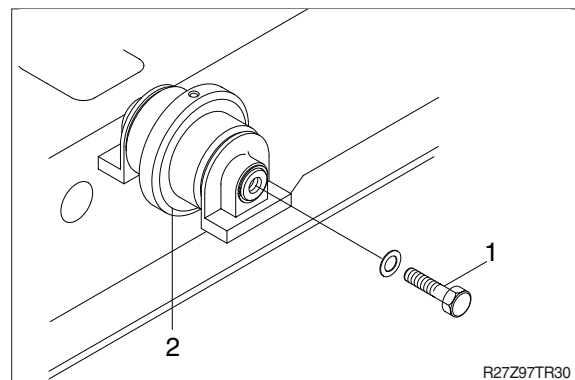

2) INSTALL

- (1) Carry out installation in the reverse order to removal.

4. IDLER AND RECOIL SPRING

1) REMOVAL

- (1) Remove the track link.
For detail, see removal of track link.
- (2) Sling the idler (1) and pull out idler and recoil spring assembly from track frame, using a pry.
 - Weight : 15 kg (33 lb)

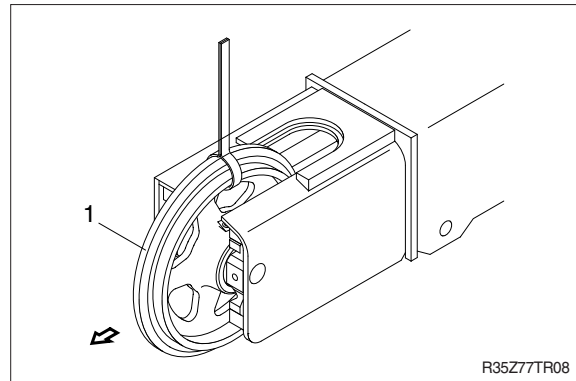

- (3) Pull out yoke and spring weld assembly from track frame, using a pry.
 - Weight : 11 kg (24 lb)

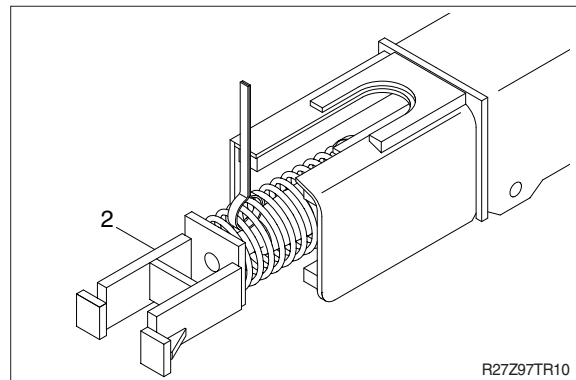

2) INSTALL

- (1) Carry out installation in the reverse order to removal.
 - ※ Make sure that the boss on the end face of the recoil cylinder rod is in the hole of the track frame.

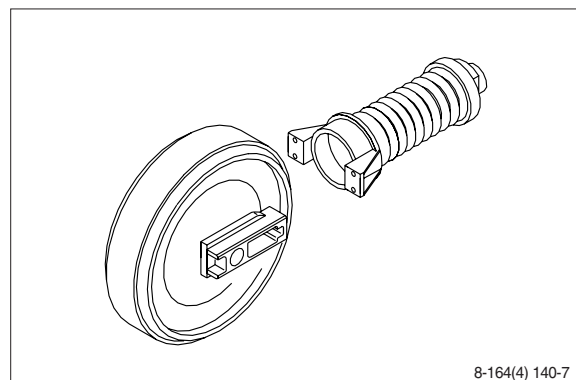

3) DISASSEMBLY AND ASSEMBLY OF IDLER

(1) Structure

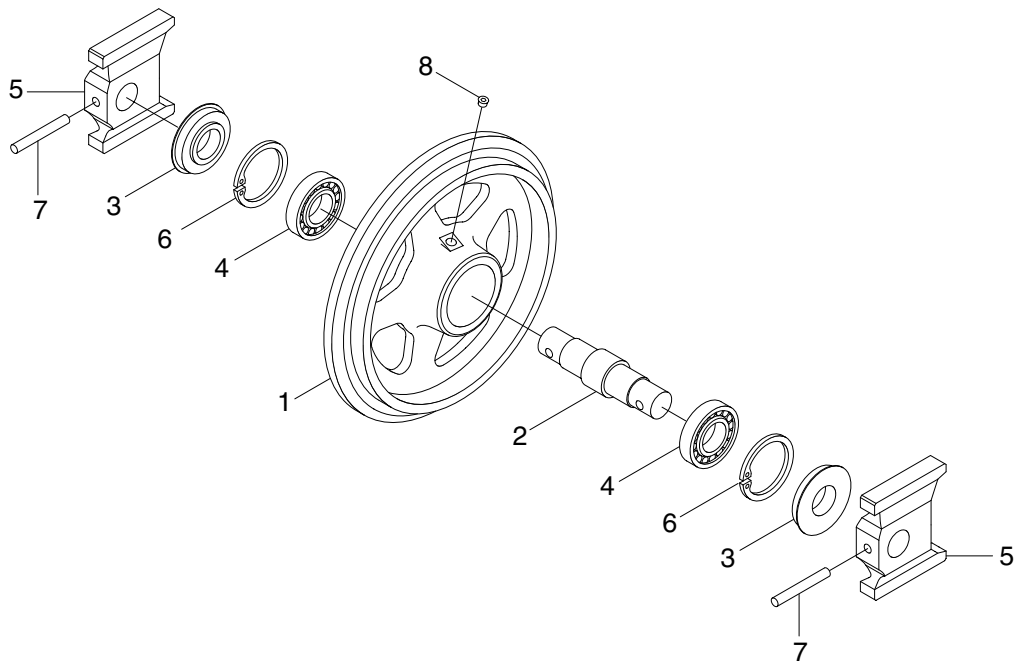

R35Z77TR11

1 Shell
2 Shaft
3 Seal assembly

4 Ball bearing
5 Bracket
6 Snap ring

7 Spring pin
8 Plug

(2) Disassembly

- ① Remove plug and drain oil.
- ② Draw out the spring pin (7), using a press.

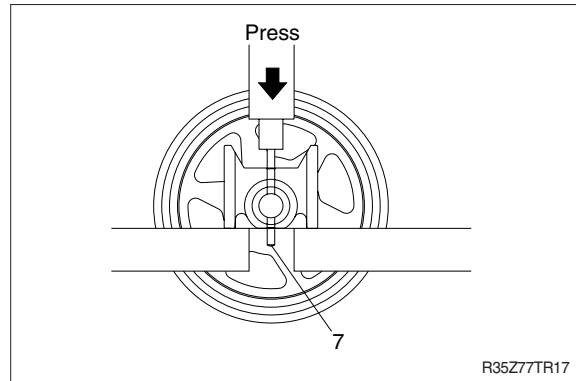

- ③ Remove brackets (2) from shaft.

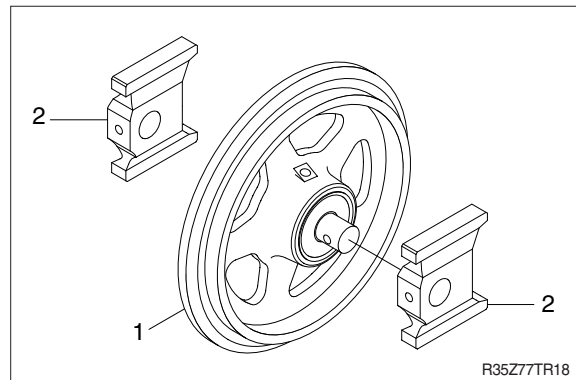

- ④ Remove seal assembly (3) from shell (1) by pry.
- ※ Do not reuse seal assembly after removal.
- ⑤ Remove snap ring (6) from shell (1)

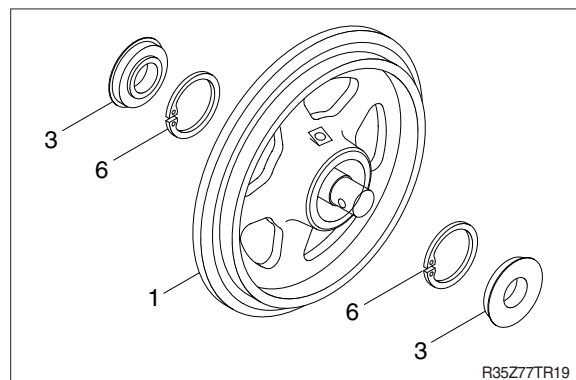

- ⑥ Draw out the ball bearing (4) with shaft (2) using press.
- ⑦ Remove the ball bearing (4) from shaft, using a special tool.
- ※ Only remove ball bearing if replacement is necessary.

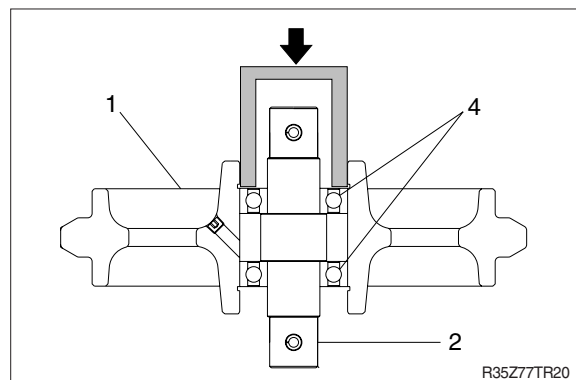

(3) Assembly

- ※ Before assembly, clean the parts.
- ※ Coat the sliding surfaces of all parts with oil.
- ① Do not press it at the normal temperature, assemble ball bearing (4) to shaft by press.

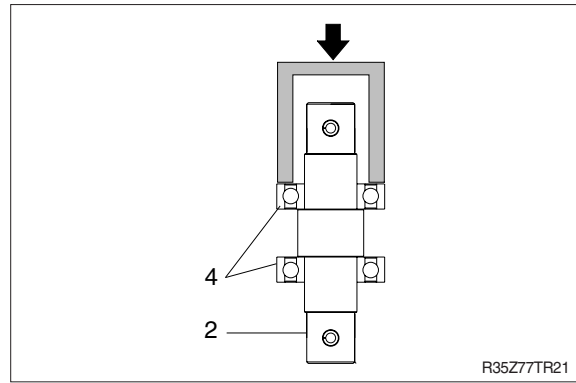

- ② Insert shaft (2) with ball bearing (4) assembly to shell (1).

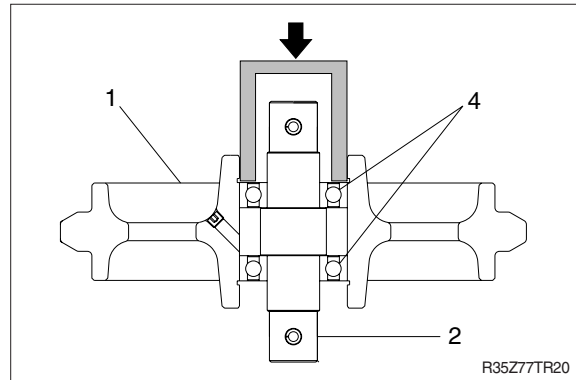

- ③ Assemble snap ring (6) and seal assembly (3).

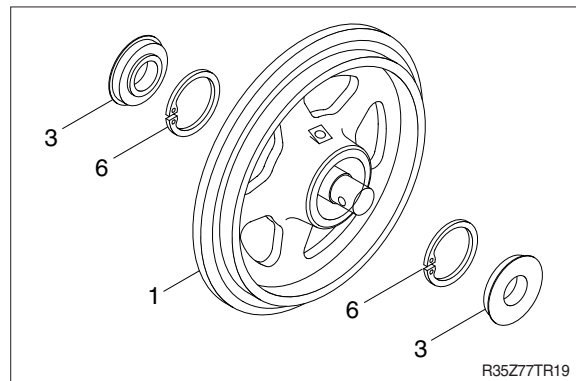

- ④ Assemble bracket (2) to shell (1).

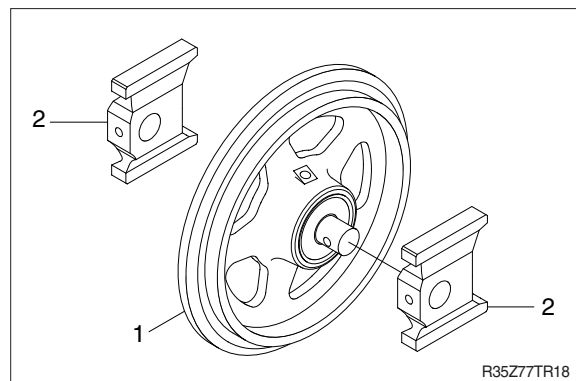

- ⑤ Install bracket (5) attached with seal (3).

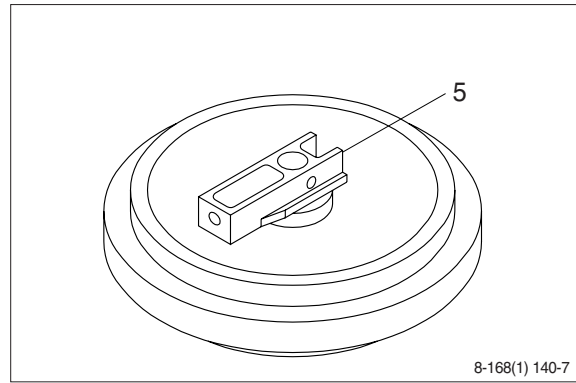

- ⑥ Knock in the spring pin (7) with a hammer.

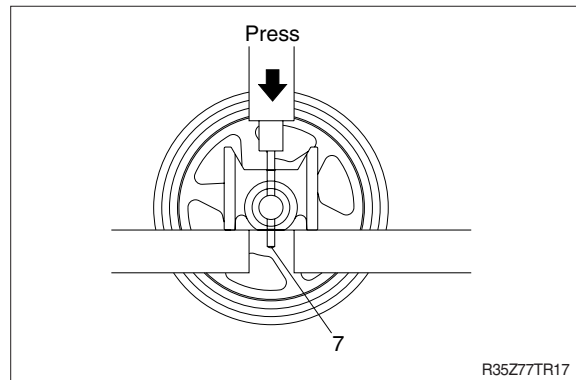

- ⑦ Lay bracket (5) on its side.
Supply engine oil to the specified level,
and tighten plug.

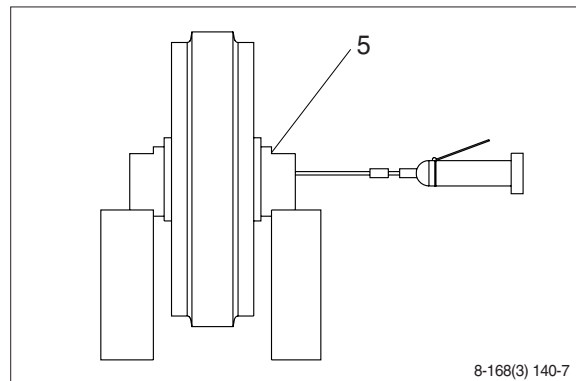

4) DISASSEMBLY AND ASSEMBLY OF RECOIL SPRING

(1) Structure

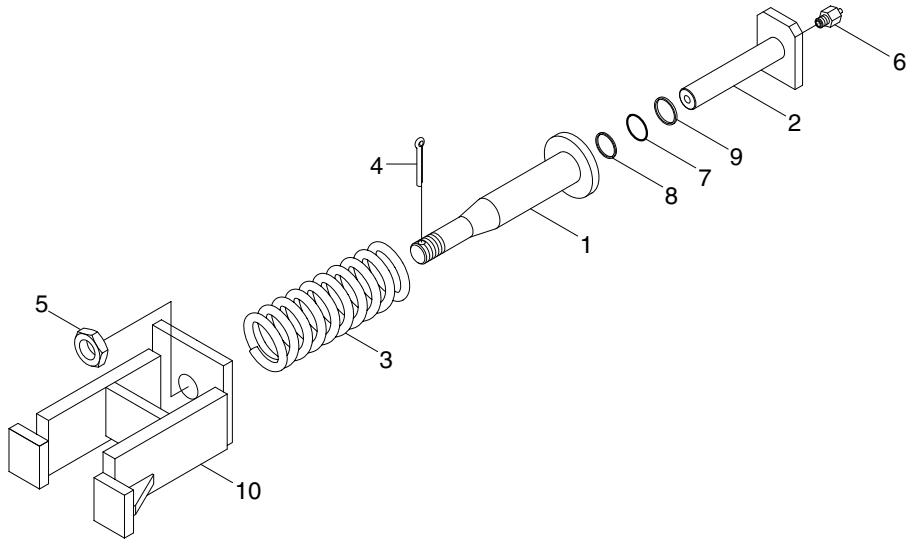

R27Z97TR12

- | | | | | | |
|---|-----------|---|--------------|----|---------|
| 1 | Body | 5 | Nut | 9 | Packing |
| 2 | Rod | 6 | Valve assy | 10 | Yoke |
| 3 | Spring | 7 | O-ring | | |
| 4 | Split pin | 8 | Back-up ring | | |

(2) Disassembly

- ① Apply pressure on yoke (10) with a press.
The spring is under a large installed load. This is dangerous, so be sure to set properly.
 - Spring set load : 1700 kg (3750 lb)
- ※ Remove split pin (4) and nut (5).
- ② Take enough notice so that the press which pushes down the spring, should not be slipped out in its operation.
- ③ Lighten the press load slowly and remove yoke (10) and spring (3).

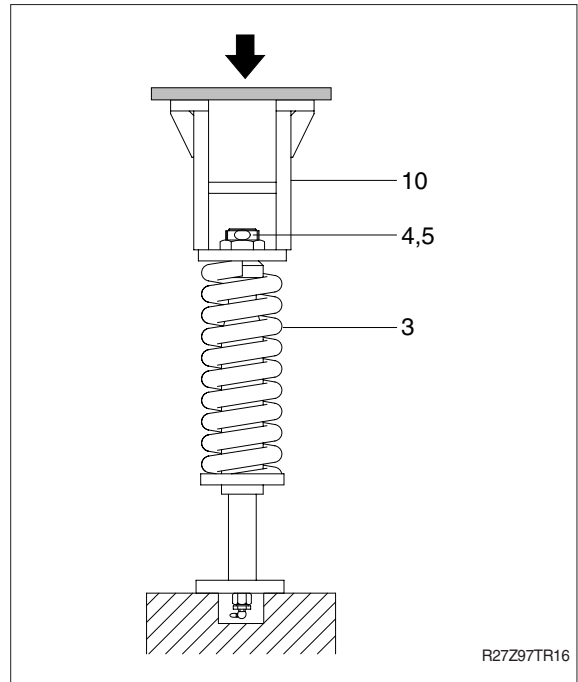

- ⑤ Remove rod (2) from body (1).
- ⑥ Remove grease valve (6) from rod (2).

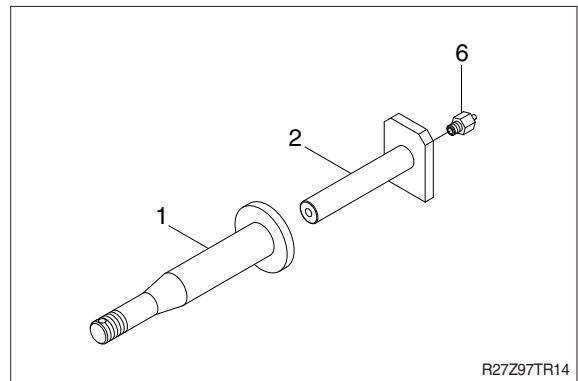

- ⑦ Remove packing (9), back-up ring (8) and O-ring (7) from body (1).

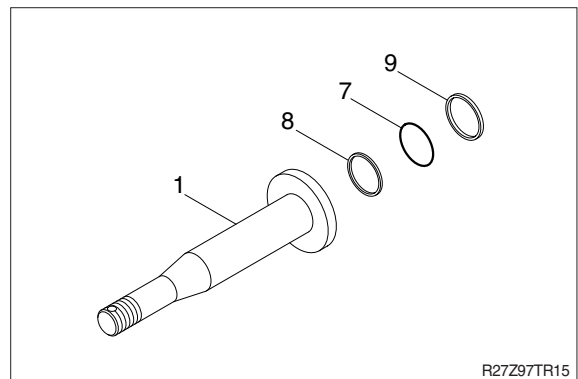

(3) Assembly

- ① Install O-ring (7), back-up ring (8), and packing (9) body (1).

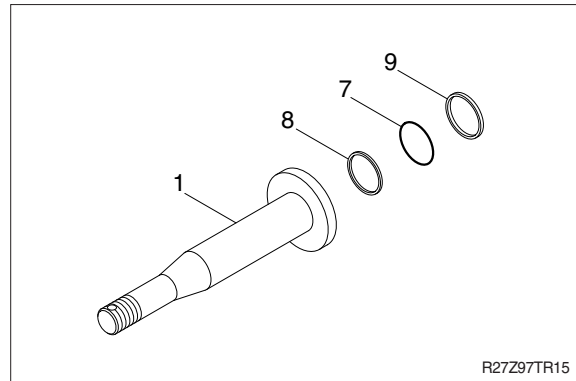

- ② Pour grease into body (1), then push in rod (2) by hand.
After take grease out of grease valve mounting hole, let air out.

※ If air letting is not sufficient, it may be difficult to adjust the tension of crawler.

- ③ Fit grease valve (6) to rod (2).
 - Tightening torque : $10 \pm 0.5 \text{ kgf} \cdot \text{m}$
($72.4 \pm 3.6 \text{ lbf} \cdot \text{ft}$)

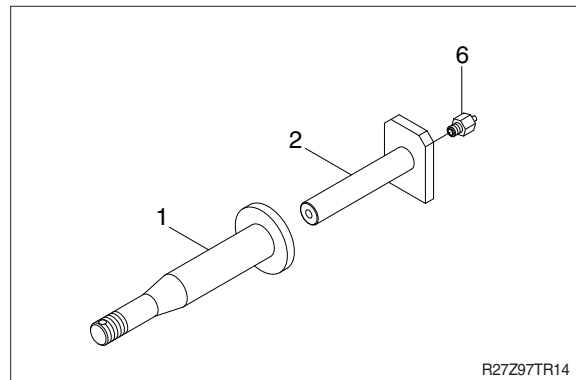

- ④ Install rod (2) to body (1).

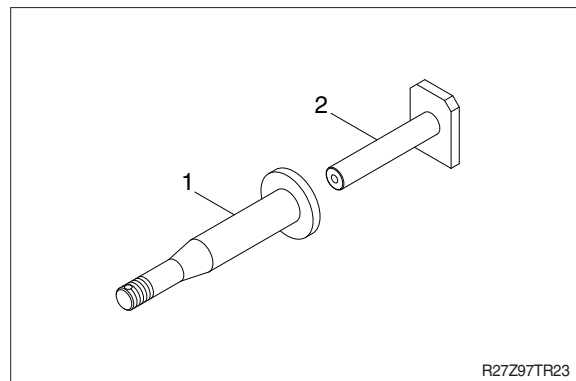

- ⑤ Install spring (3) and yoke (10) to body (1).
- ⑥ Apply pressure to spring (3) with a press and tighten nut (5).
- ※ During the operation, pay attention specially to prevent the press from slipping out.
- ⑦ Tighten nut (5) and insert split pin (4).

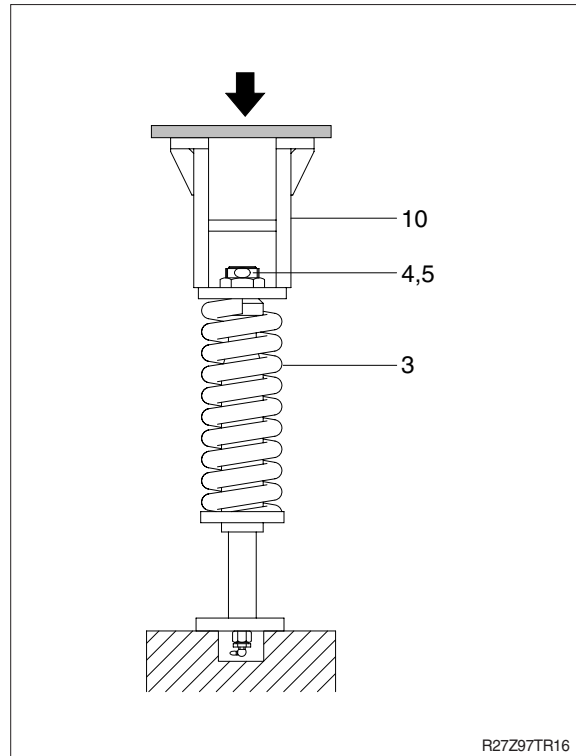

- ⑧ Lighten the press load and confirm the set length of spring (3).
 - Spring length : 230 mm (9.1")

