

GROUP 2 MAIN CONTROL VALVE

1. OUTLINE

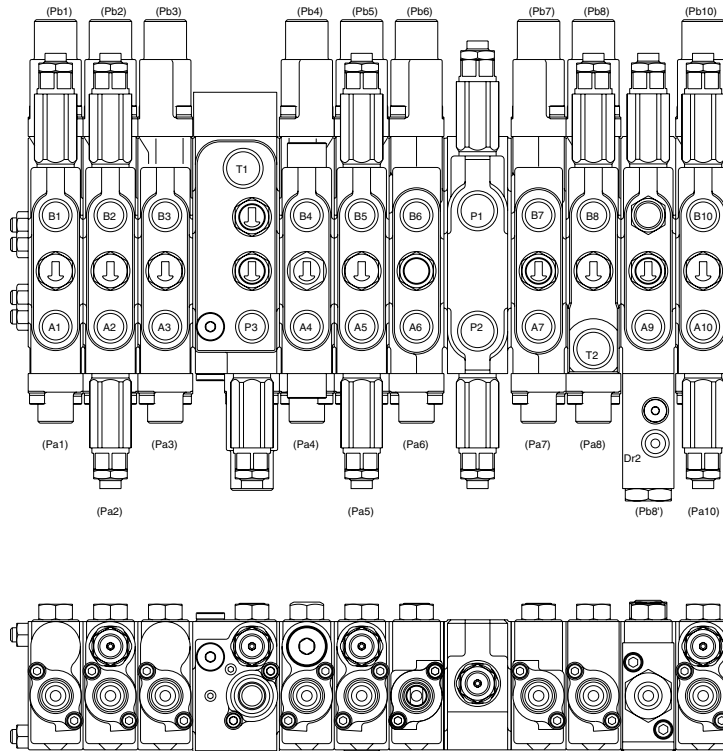

R35Z72MVC01

Mark	Port name	Port size	Tightening torque	Mark	Port name	Port size	Tightening torque
P1	P1 (A1) pump port	PF 1/2	6~7 kgf · m	A10	Bucket out port	PF 3/8	4.0~5.0 kgf · m
P2	P2 (A2) pump port			B10	Bucket in port		
T1	Tank return port			Pa1	Dozer down pilot port	PF 1/4	2.5~3.0 kgf · m
T2	Tank return port	Pb1	Dozer up pilot port				
P3	P3 (A3) pump port	Pa2	Boom swing (RH) pilot port				
A1	Dozer	Pb2	Boom swing (LH) pilot port				
B1	Dozer	Pa3	Swing (RH) pilot port				
A2	Boom swing (RH) port	Pb3	Swing (LH) pilot port				
B2	Boom swing (LH) port	Pa5	Arm out pilot port				
A3	Swing (LH) port	Pb5	Arm in pilot port				
B3	Swing (RH) port	Pa6	Travel [LH/RR] pilot port				
A4	Option port	Pb6	Travel [LH/FW] pilot port				
B4	Option port	Pa7	Travel [RH/RR] pilot port				
A5	Arm out port	Pb7	Travel [RH/FW] pilot port				
B5	Arm in port	Pa8	Boom up pilot port				
A6	Travel [LH/RR] port	Pb8	Boom down pilot port				
B6	Travel [LH/FW] port	Pa10	Bucket out pilot port				
A7	Travel [RH/RR] port	Pb10	Bucket in pilot port				
B7	Travel [RH/FW] port						
A9	Boom up port						
B8	Boom down port						

2. STRUCTURE (1/3)

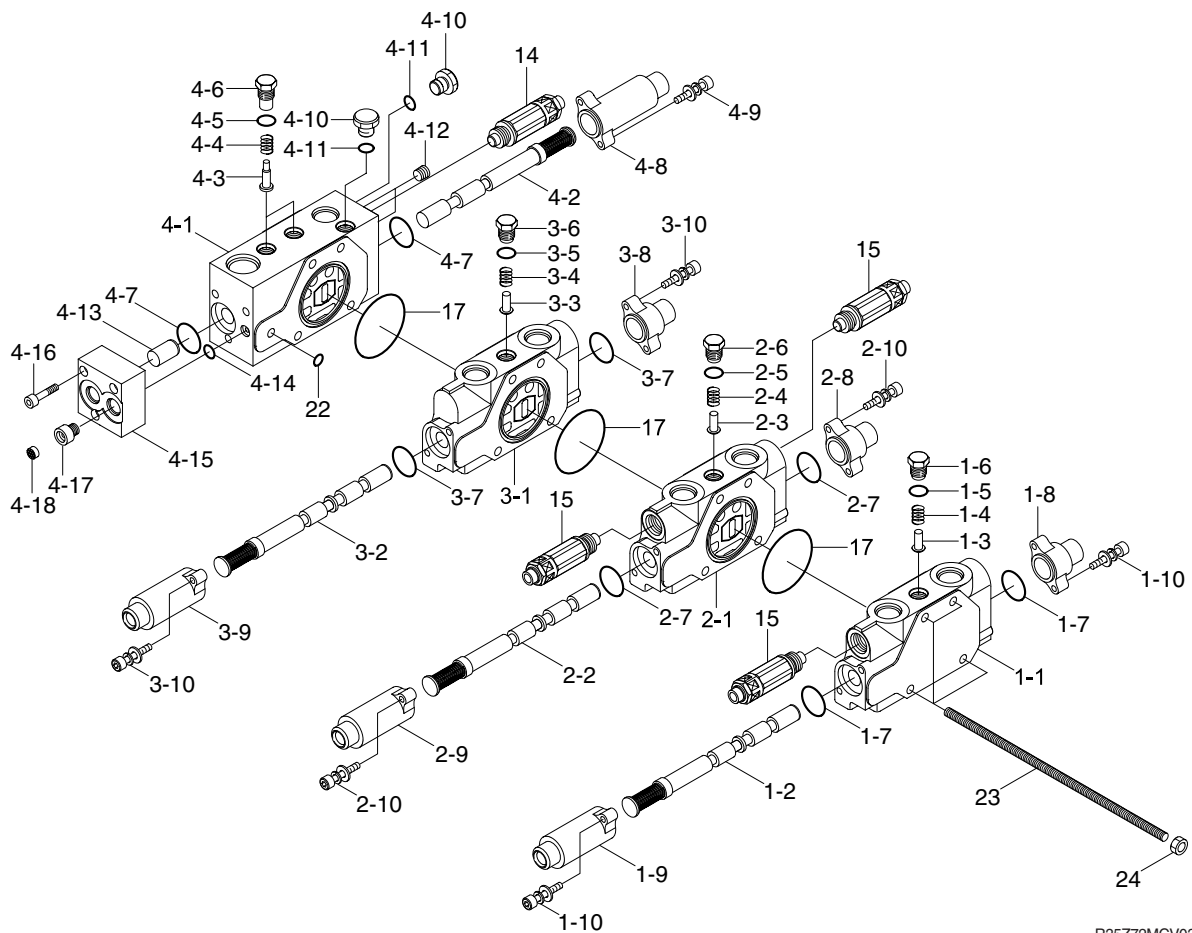

R35Z72MCV03

- | | | | | | |
|------|------------------------|------|------------------------|------|------------------------|
| 1 | Dozer work block | 2-9 | Cover-pilot | 4-6 | Plug |
| 1-1 | Body-work | 2-10 | Bolt-soc head w/washer | 4-7 | O-ring |
| 1-2 | Spool assy | 3 | Swing work block | 4-8 | Cover-pilot |
| 1-3 | Poppet | 3-1 | Body-work | 4-9 | Bolt-soc head w/washer |
| 1-4 | Spring | 3-2 | Spool assy | 4-10 | Plug |
| 1-5 | O-ring | 3-3 | Poppet | 4-11 | O-ring |
| 1-6 | Plug | 3-4 | Spring | 4-12 | Plug |
| 1-7 | O-ring | 3-5 | O-ring | 4-13 | Piston |
| 1-8 | Cover-pilot | 3-6 | Plug | 4-14 | O-ring |
| 1-9 | Cover-pilot | 3-7 | O-ring | 4-15 | Body-pilot |
| 1-10 | Bolt-soc head w/washer | 3-8 | Cover-pilot | 4-16 | Bolt-soc head w/washer |
| 2 | Boom swing work block | 3-9 | Cover-pilot | 4-17 | Orifice |
| 2-1 | Body-work | 3-10 | Bolt-soc head w/washer | 4-18 | Filter-coin type |
| 2-2 | Spool assy | 4 | Connecting block | 14 | Relief valve |
| 2-3 | Poppet | 4-1 | Body-work | 15 | Overload relief valve |
| 2-4 | Spring | 4-2 | Spool assy | 17 | O-ring |
| 2-5 | O-ring | 4-3 | Poppet | 22 | O-ring |
| 2-6 | Plug | 4-4 | Spring | 23 | Bolt-tie |
| 2-7 | O-ring | 4-5 | O-ring | 24 | Nut-hex |
| 2-8 | Cover-pilot | | | | |

STRUCTURE (2/3)

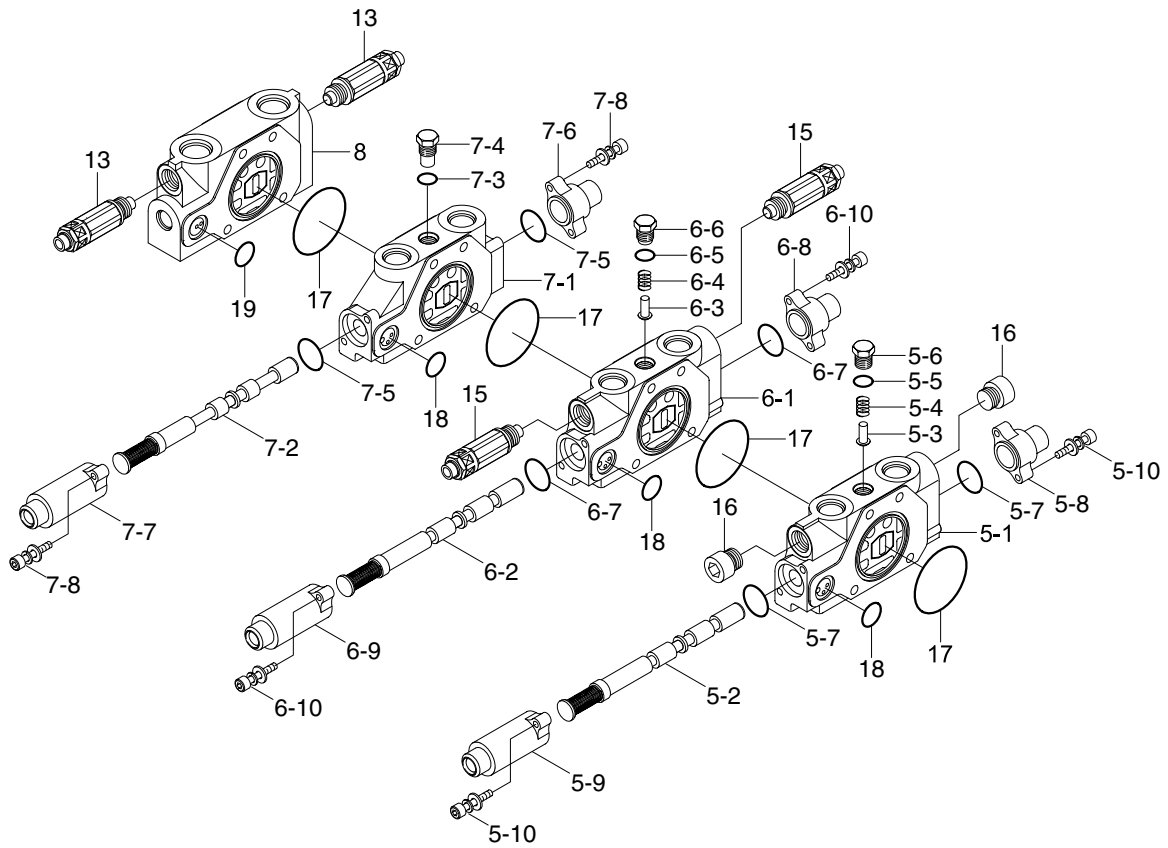

R35Z72MCV04

5	PTO work block	6-2	Spool assy	7-4	Plug
5-1	Body-work	6-3	Poppet	7-5	O-ring
5-2	Spool assy	6-4	Spring	7-6	Cover-pilot
5-3	Poppet	6-5	O-ring	7-7	Cover-pilot
5-4	Spring	6-6	Plug	7-8	Bolt-soc head w/washer
5-5	O-ring	6-7	O-ring	8	Inlet work block
5-6	Plug	6-8	Cover-pilot	13	Relief valve
5-7	O-ring	6-9	Cover-pilot	15	Overload relief valve
5-8	Cover-pilot	6-10	Bolt-soc head w/washer	16	Plug
5-9	Cover-pilot	7	Travel work block	17	O-ring
5-10	Bolt-soc head w/washer	7-1	Body work	18	O-ring
6	Arm work block	7-2	Spool assy	19	O-ring
6-1	Body-work	7-3	O-ring		

STRUCTURE (3/3)

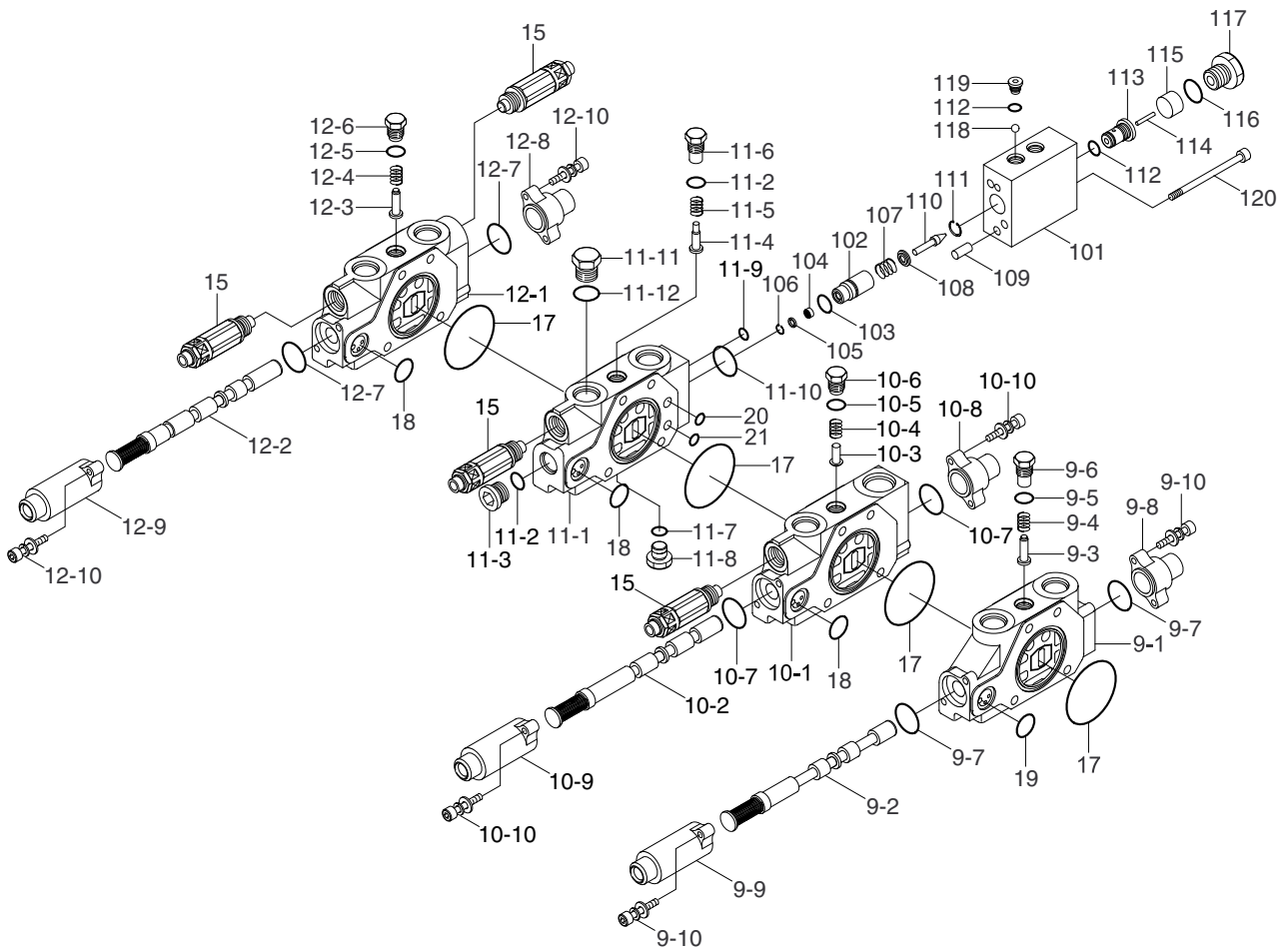

R35Z72MCO5

9	Travel work block	10-7	O-ring	12-1	Body-work	103	Seal
9-1	Body-work	10-8	Cover-pilot	12-2	Spool assy	104	Filter
9-2	Spool assy	10-9	Cover-pilot	12-3	Poppet	105	Spacer
9-3	Poppet	10-10	Bolt-soc head w/washer	12-4	Spring	106	Ring-retaining
9-4	Spring	11	Boom lock valve	12-5	O-ring	107	Spring A-lock valve
9-5	O-ring	11-1	Body-work	12-6	Plug	108	Spring seat
9-6	Plug	11-2	O-ring	12-7	O-ring	109	Pin
9-7	O-ring	11-3	Plug	12-8	Cover-pilot	110	Poppet
9-8	Cover-pilot	11-4	Poppet	12-9	Cover-pilot	111	Ring-retaining
9-9	Cover-pilot	11-5	Spring	12-10	Bolt-soc head w/washer	112	O-ring
9-10	Bolt-soc head w/washer	11-6	Plug	15	Overload relief valve	113	Guide-piston
10	Boom work block	11-7	O-ring	17	O-ring	114	Piston A1
10-1	Body-work	11-8	Plug	18	O-ring	115	Piston B
10-2	Spool assy	11-9	O-ring	19	O-ring	116	O-ring
10-3	Poppet	11-10	O-ring	20	O-ring	117	Connector
10-4	Spring	11-11	Plug	21	O-ring	118	Ball-steel
10-5	O-ring	11-12	O-ring	101	Cover-lock valve	119	Plug
10-6	Plug	12	Bucket work block	102	Lock valve	120	Bolt-hex. socket head

3. HYDRAULIC CIRCUIT

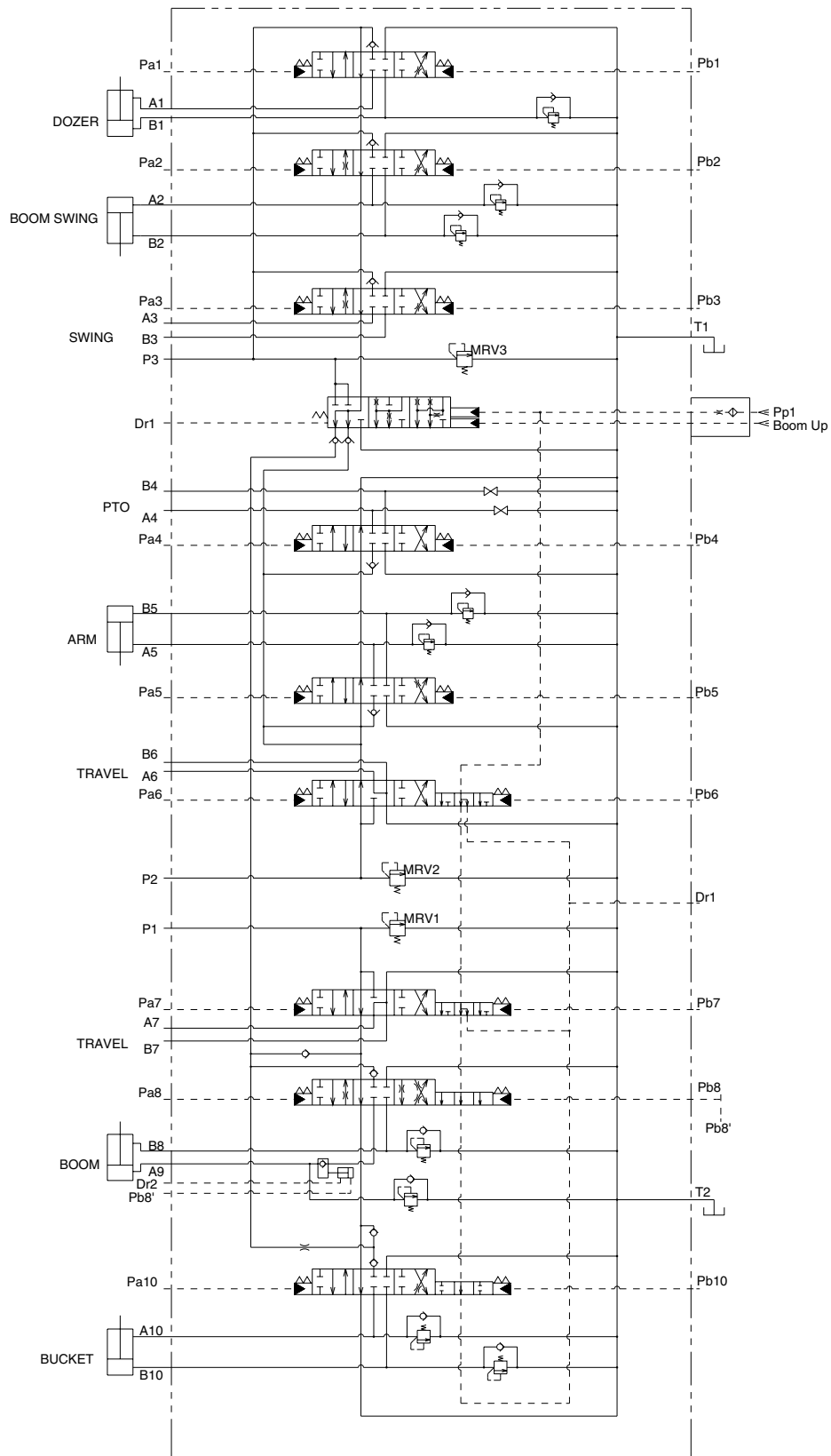

R35Z72MCV02

4. FUNCTION

1) IN NEUTRAL (When all spools are in neutral position)

P1 : The oil discharged from the hydraulic pump flows into control valve P1 port, and then flows through P1 and P2 supply body the P1 side travel spool. The oil flows through the bypass passage in the direction of travel → boom → bucket spool, and then flows from the bypass passage to the tank passage in the bucket section.

P2 : The oil discharged for the hydraulic pump flows into the control valve from P2 port, and then flows through P1 and P2 supply body to the P2 side travel spool. The oil flows through the bypass passage in the direction of travel → arm → PTO spool, and the flows from the bypass passage to the tank passage in the PTO section.

P3 : The oil discharged from the hydraulic pump flows into the control valve from P3 port, and then flows through the parallel passage of dozer, boom swing, and swing. The oil that has followed into the parallel passage flows through the bypass passage in the direction of dozer → Boom swing → swing spool, the connecting spool land, the P2 side parallel passage, the bypass passage from arm to PTO spool, the bypass passage in the PTO section, and then to the tank passage.

※ **Since each line (P1, P2, P3) is supplied with oil from the pump, the section is operatable; therefore, do not operate the control valve except the working time.**

- P1 line : Travel, boom, bucket
- P2 line : Travel, arm, PTO
- P3 line : Dozer, boom swing, arm, PTO, boom (up only)

P_P1 : When P_P1 port is applied with pilot pressure, the oil flows into the travel independent passage via an orifice.

With the spool in neutral, the oil flows into Dr1 port provided in the P1 and P2 supply body.

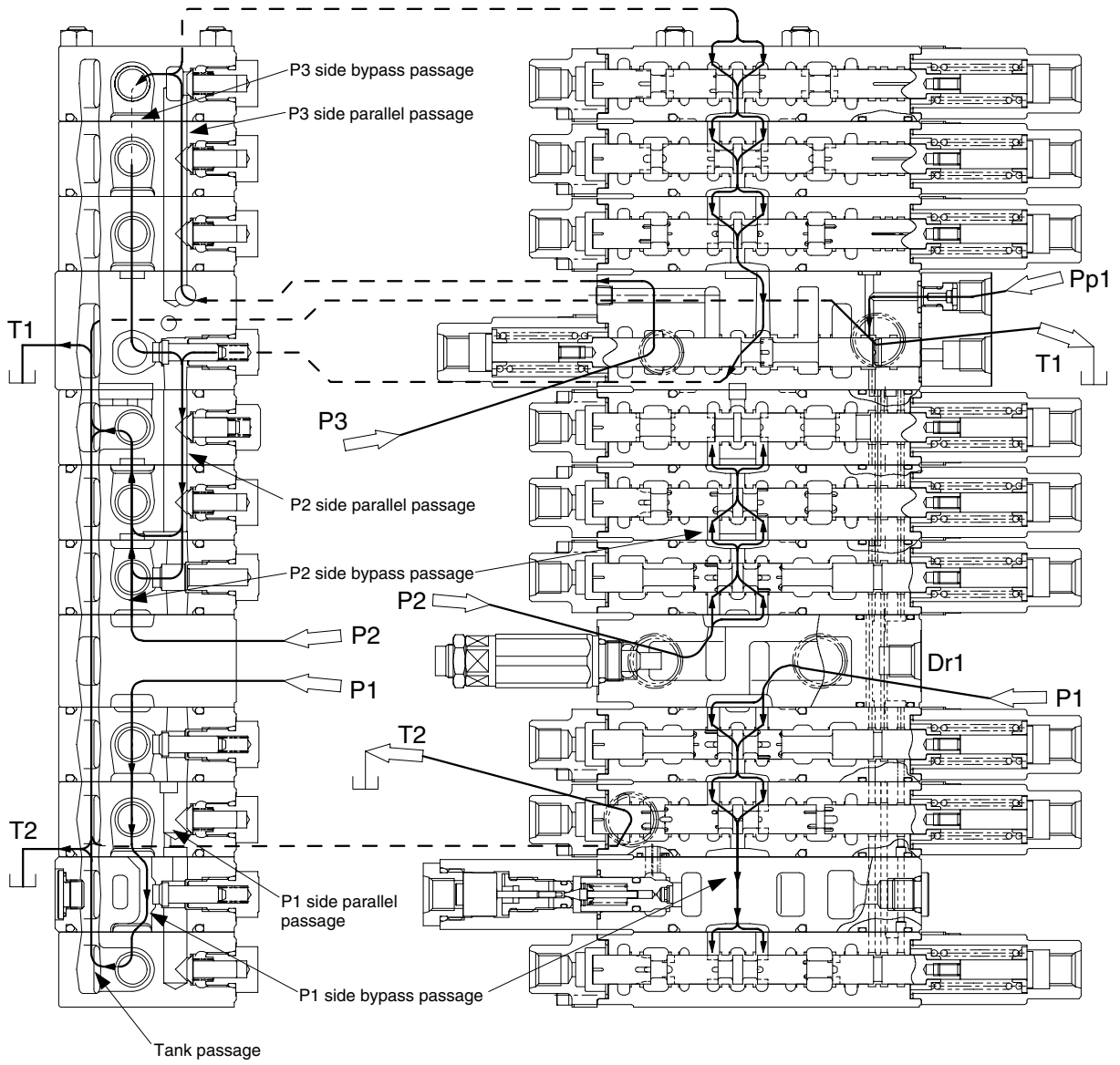

Hydraulic oil flow in neutral

2) TRAVEL OPERATION

For the travel operation, both Pa pressurization and Pb pressurization are the same on operation so that only Pa pressurization is explained as follows.

When left (right) travel reverse is operated, the secondary pressure from the remote control valve is applied to Pa6 [Pa7] port to change over the travel spool. The oil flowed from P2 [P1] port flows through the supply body into the P2 [P1] side bypass passage. The oil flowed into the P2 [P1] side bypass passage flows through A6 [A7] port that has been opened by the spool changeover to the travel motor. On the other hand, the oil returned from the travel motor flows into the control valve from B6 [B7] port and then to the tank passage has been opened after the spool changeover.

The oil flowed from Pp1 port flows through the orifice passage provided in the P3 supply section into the travel independent signal passage.

Although the travel independent passage (see page 2-14) in the travel section that has been opened during neutral is blocked after the both travel spools changeover, the travel independent signal passage is connected to the drain port via the bucket section. Accordingly, when the bucket section has not changed over, the connecting spool in the P3 supply section does not change over because the pressure in the travel independent signal passage is equal to the drain pressure.

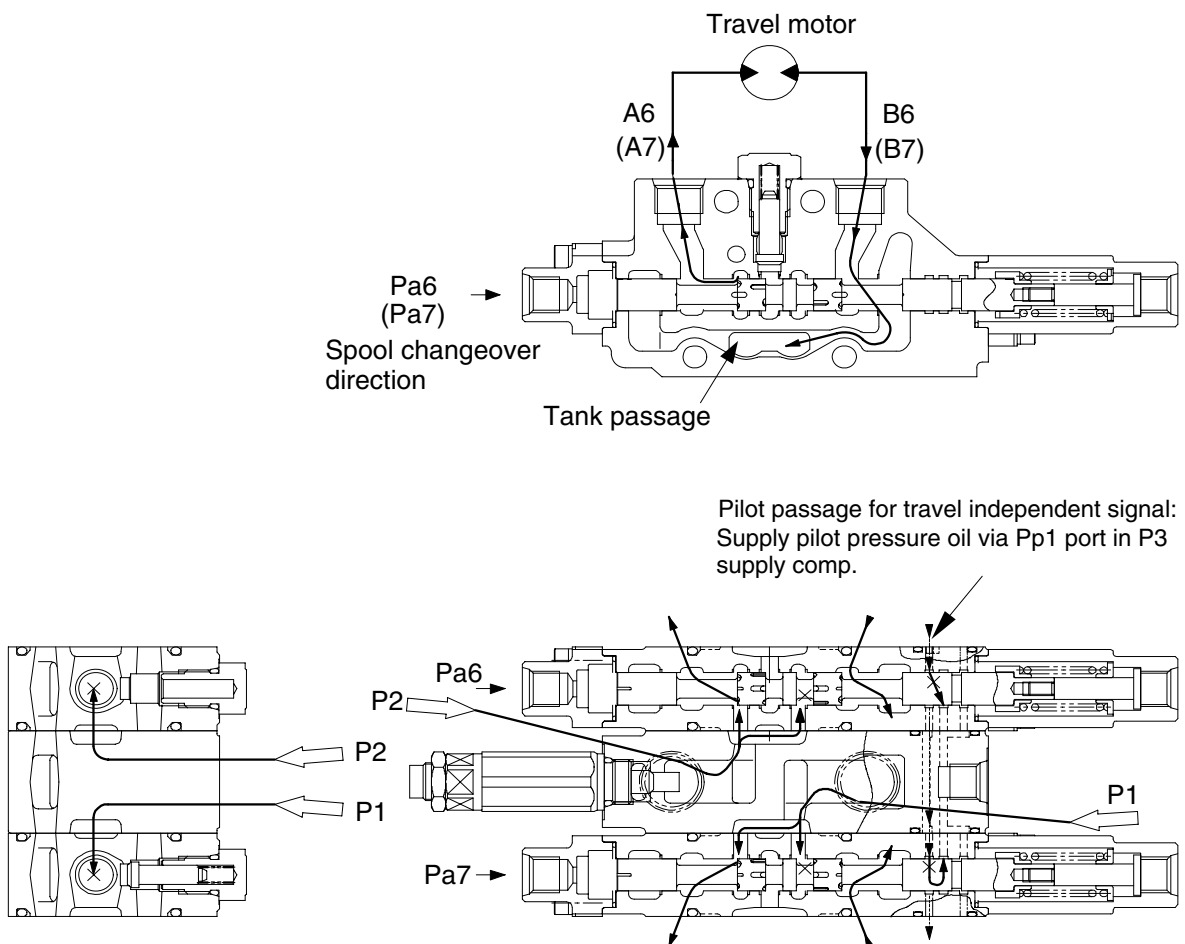

Operation during travel(Forward)

R35Z72MCV12

3) BOOM OPERATION

Boom up operation

When the boom up operation is carried out, the secondary pressure from the remote control valve is applied to Pa8 port to change over the boom spool. Since Pa8 port is connected to boom up port through the piping, the pressure oil supplied to boom up port changes over the connecting spool through the connecting piston in the P3 supply section

Also, since the P1 side bypass passage is shut off at the boom section after the boom spool changeover, the oil flowed from P1 port flows through the check valve provided above the bypass passage in the travel section into the P1 side parallel passage.

On the other side, after the connecting spool changeover the oil flowed into P3 port.

- ① Flows through the internal passage in connecting spool and the check valve in the P3 supply section into the P1 side parallel passage.
- ② The oil flows through the P3 side parallel passage and P3 side bypass passage and then:
 - a. Flows through the check valve in the P3 supply section into the P1 side parallel passage.
 - b. Some oil flows through the orifice passage provided in the connecting spool and the check valve in the P3 supply section into the P2 side parallel passage.

The oil flowed into the P1 side parallel passage is connected with the oil from P1 pump.

The oil flowed into the P2 side parallel passage flows through the bypass passages in the arm section and PTO section to the tank passage.

Since the passage connected to the boom lock valve and the bridge passage are opened after the boom spool changeover, the oil flowed into the P1 side parallel passage flows through the load check valve in the boom section and the bridge passage into the boom lock valve section

The oil flowed into the boom lock valve section opens the lock valve (free flow condition), flows into A9 port, and then to the head side of the boom cylinder.

On the other hand, the oil returned from the rod side of the boom cylinder flows into B8 port to the tank passage that has opened with the spool's notch after the spool changeover. Then, the boom cylinder extends to raise the boom.

P1 side circuit

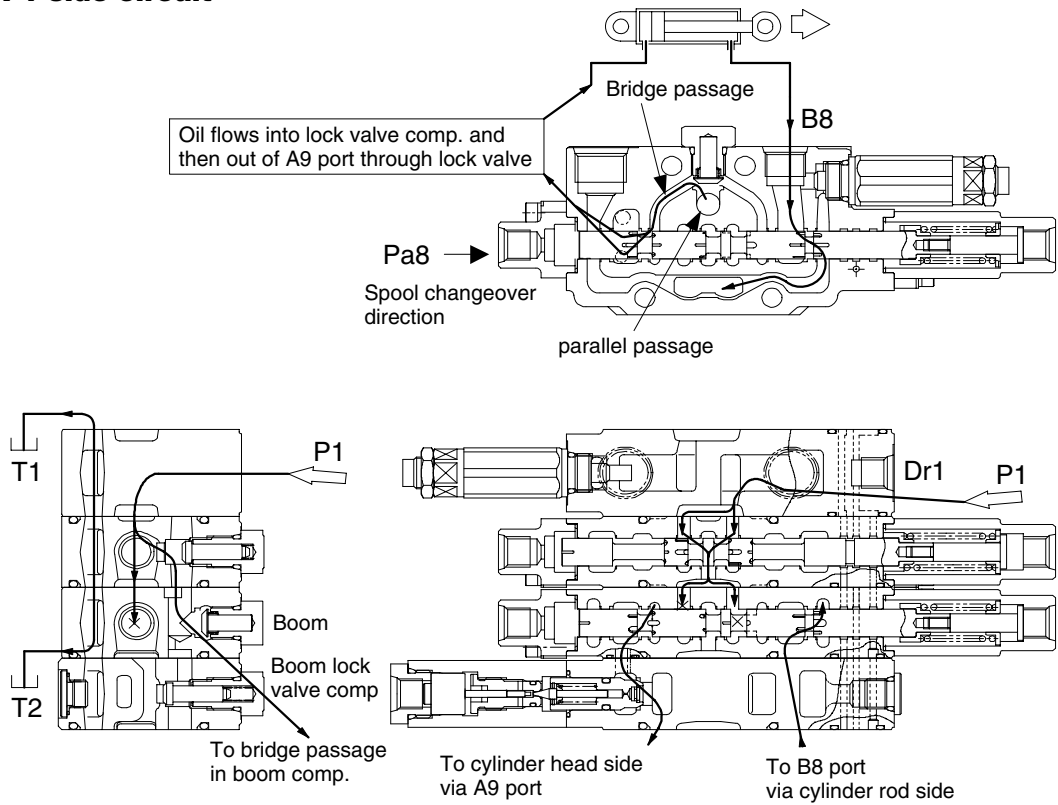

P3 side (Connecting side) circuit

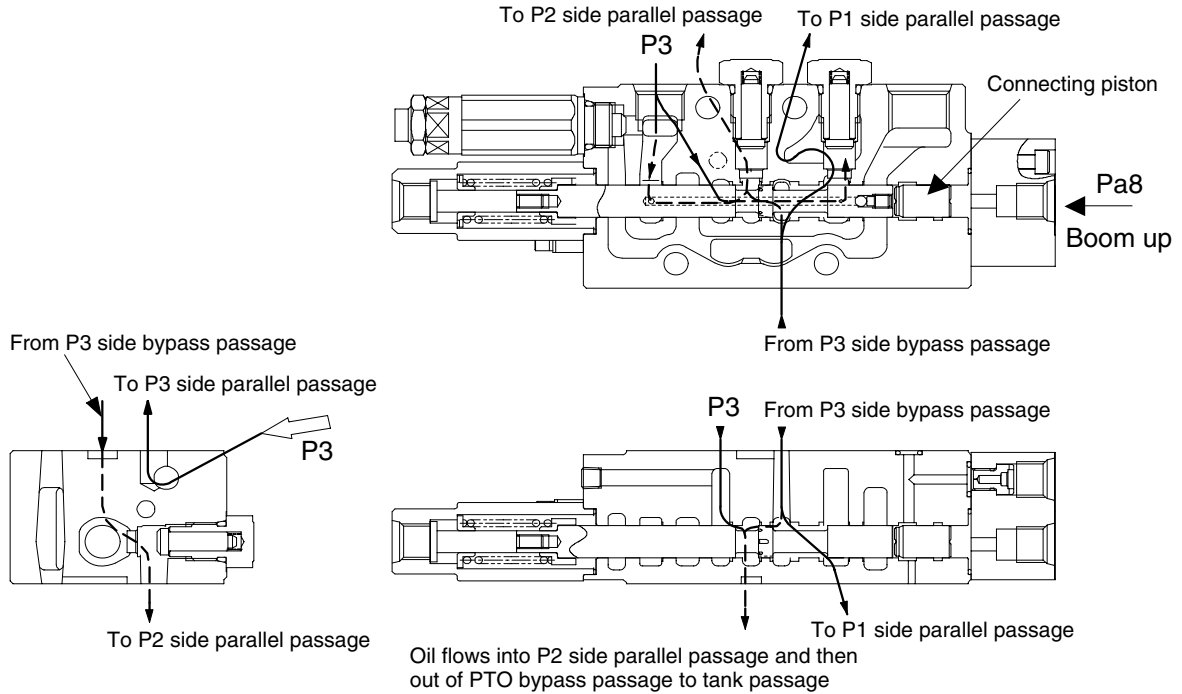

Boom up operation

R35Z72MCV13

Boom down operation

When the boom down operation is carried out, the secondary pressure from the remote control valve is applied to Pb8 port to change over the boom spool.

Since Pb8 port is connected to Pb8' port through the piping, the pressure is also applied to pb8' port (Boom lock valve release port) to release the boom lock valve.

(For the explanation of boom lock valve operation, see pages 2-19, 20)

Since the bypass passage is shut off at the boom section after the spool changeover (some oil flows through the orifice passage provided in the boom spool's bypass passage to the downstream side of the bypass passage), the oil flowed from P1 port flows through the check valve provided above the bypass passage in the travel section into the P1 side parallel passage.

Also, since a passage between B8 port and bridge passage is opened with the spool's notch after the spool changeover, the oil flowed into the P1 side parallel passage flows through the load check valve in the boom section into B8 port via the bridge passage and then into the rod side of the boom cylinder.

On the other side, the oil returned from the head side of the boom cylinder flows into A9 port to the tank passage that has been opened with the spool's notch after the spool changeover through the boom lock valve that has been released by Pb8' port pressure. Then, the boom cylinder retracts to lower the boom.

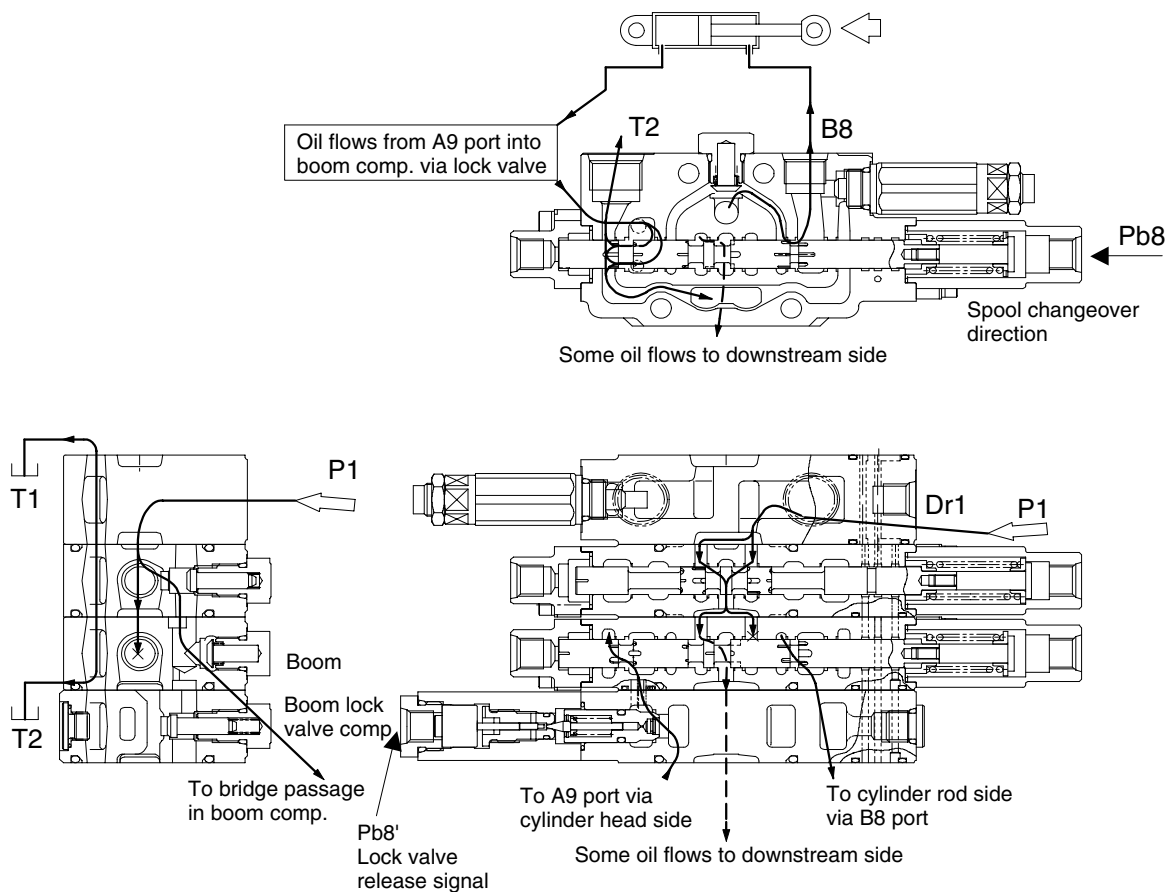

Boom down operation

R35Z72MCV14

4) Operation of boom lock valve

(1) Holding

In the boom spool neutral condition,

- The pilot piston chamber (a) is connected to the drain passage through the pilot port (Pb8') for releasing the boom lock valve.
- The piston chamber (b) is also connected to the drain passage through the drain port (Dr2).

Therefore, the piston (B) maintains the condition shown in the figure.

The boom cylinder holding pressure (shown in half-tone dot meshing) is applied to the lock valve chamber as shown in the figure to :

- Press the needle valve against the needle valve seat.
- Press the lock valve against the body seat.

Then, oil leakage from the boom cylinder head side is prevented to stop the movement of the boom cylinder due to leakage.

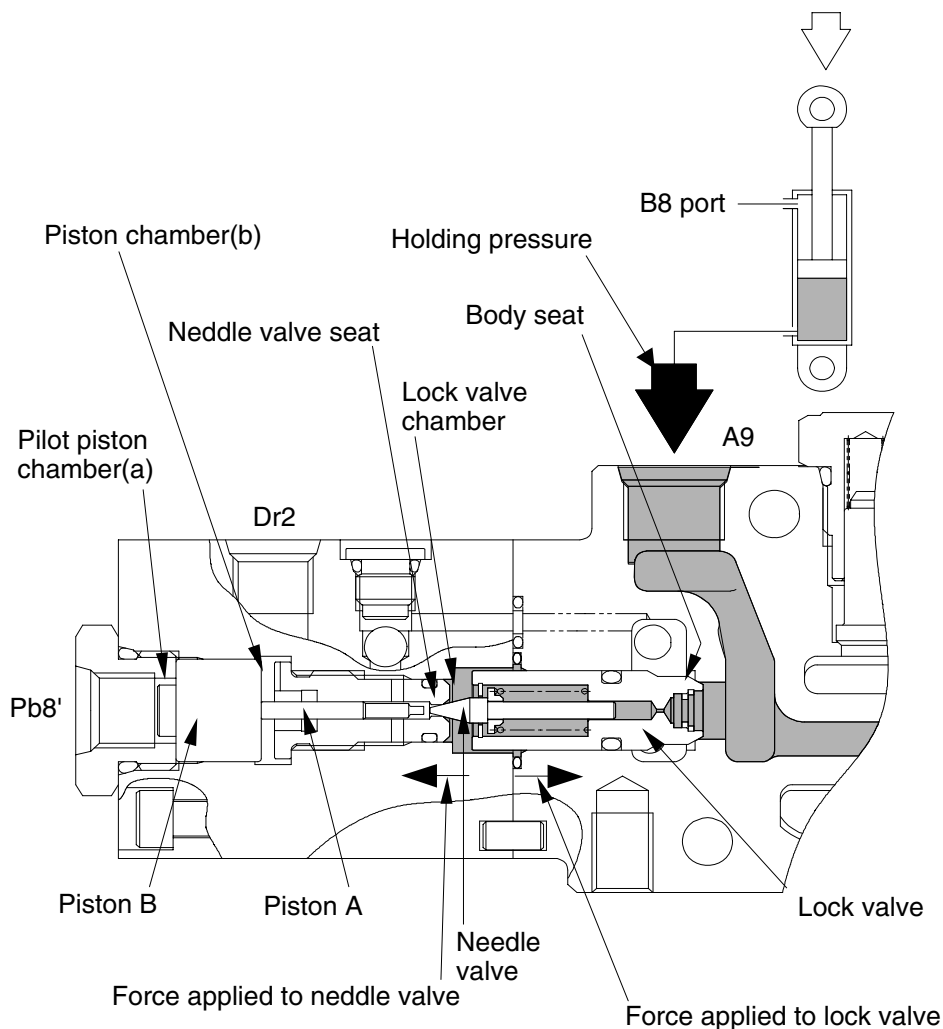

Operation of boom lock valve (holding)

R35Z72MCV15

(2) Release

When the pilot pressure is applied to the pilot port (Pb8') for boom lock valve release, the piston (B) moves rightward to open the needle valve through the piston (A1).

Then, the oil returned from the boom cylinder flows through the passage in the direction of lock valve's orifice → lock valve chamber → needle valve seat → check valve into the lock valve's downstream side chamber (boom section).

When the lock valve's downstream chamber is connected to the tank passage after the boom spool changeover and the needle valve is released, the pressure in the lock valve chamber decreases to open the lock valve by the oil returned from the boom cylinder. The returned oil flows into the tank passage with the boom spool's notch to operate the cylinder.

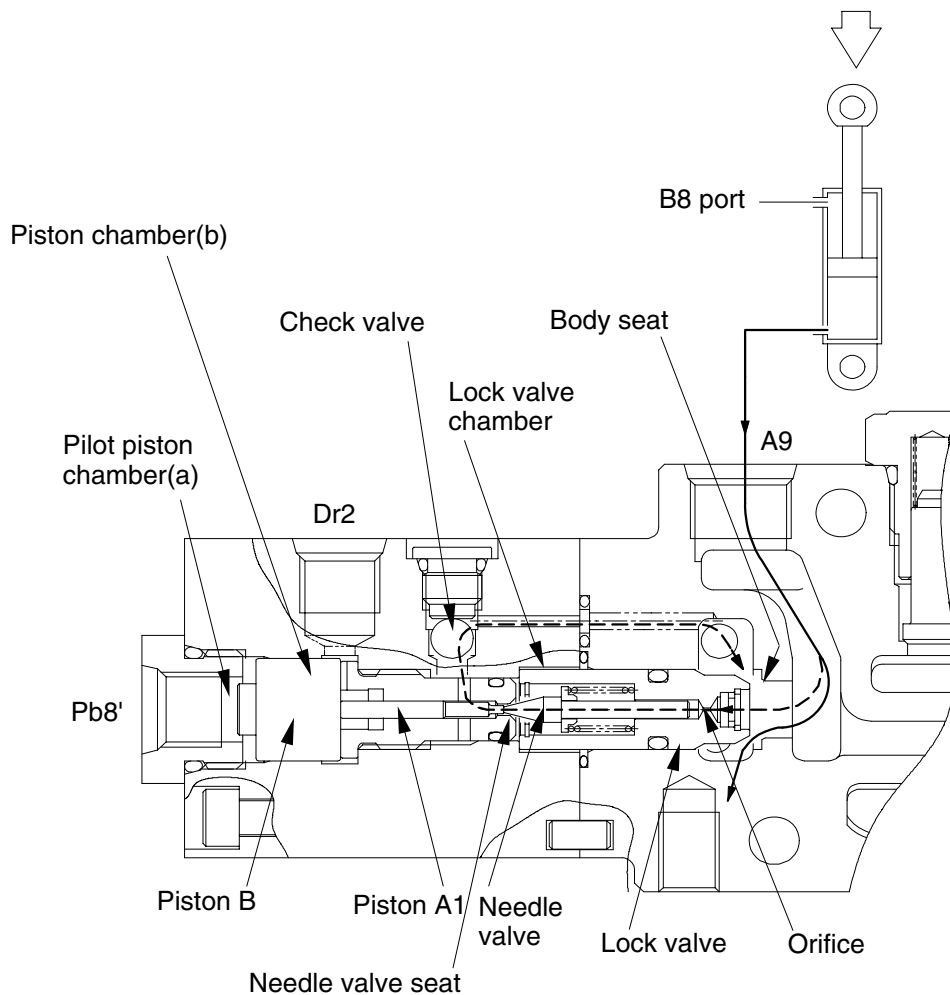

Operation of boom lock valve (release)

R35Z72MCV16

5) BUCKET OPERATION

Bucket in operation

When the bucket in operation is carried out, the secondary pressure from the remote control valve flows into Pb10 port to change over the bucket spool.

Since the P1 side bypass passage is shut off at the bucket section after the bucket spool changeover, the oil flowed from P1 port flows through the check valve provided above the bypass passage in the travel section into the P1 side parallel passage.

Also, since a passage between B10 port and the bridge passage is opened after the spool changeover, the oil flowed into the P1 side parallel passage flows through the load check valve in the bucket section into B10 port via the bridge passage and then the head side of the bucket cylinder.

On the other hand, the oil returned from the rod side of the bucket cylinder flows into A10 port to the tank passage that has opened with the spool's notch after the spool changeover. Then, the bucket cylinder extends to make the bucket in.

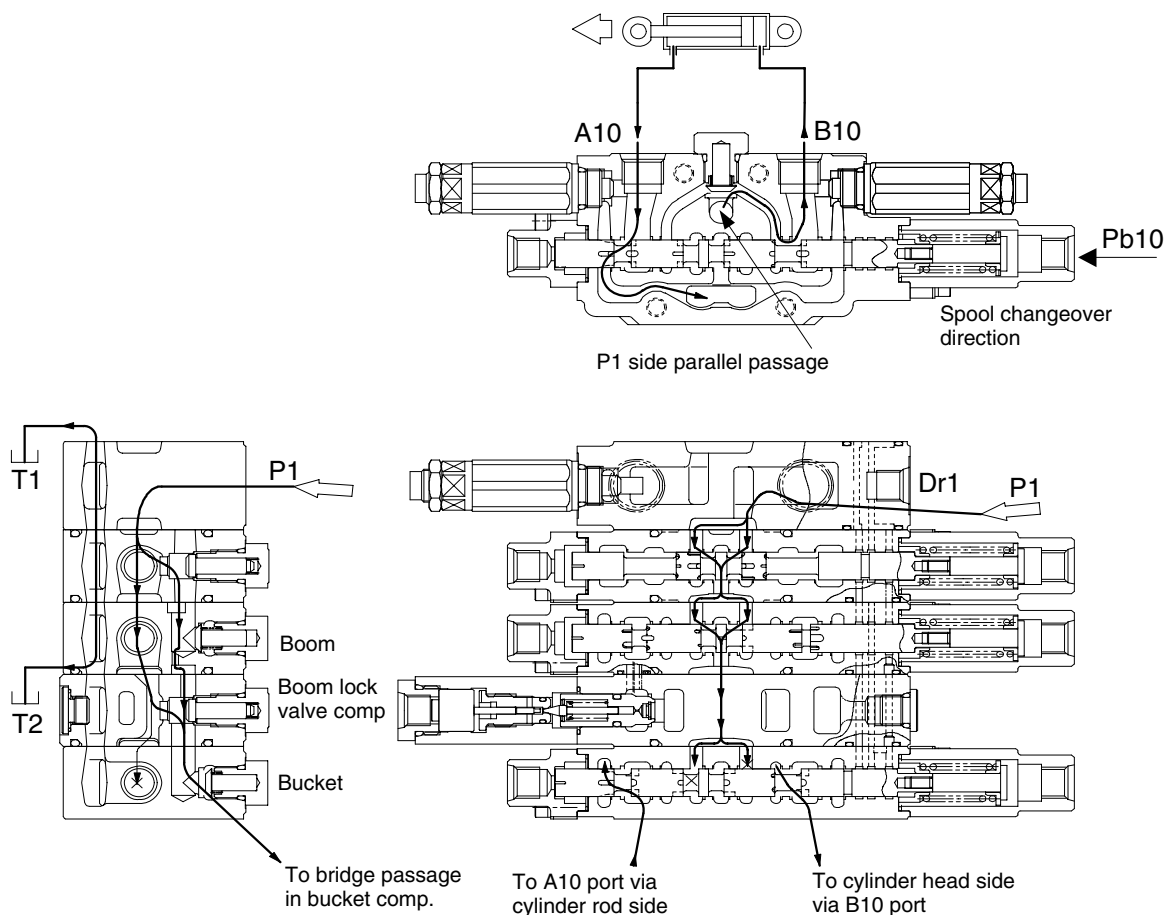

Bucket in operation

Bucket out operation

When the bucket out operation is carried out, the secondary pressure from the remote control valve flows into Pa10 port to change over the bucket spool.

Since the P1 side bypass passage is shut off at the bucket section after the bucket spool changeover, the oil flowed from P1 port flows through the check valve provided above the bypass passage in the travel section into the P1 side parallel passage.

Also, since a passage between A10 port and the bridge passage is opened after the spool changeover, the oil flowed into the P1 side parallel passage flows through the load check valve in the bucket section into A10 port via the bridge passage and then the head side of the bucket cylinder.

On the other hand, the oil returned from the head side of the bucket cylinder flows into B10 port to the tank passage that has opened after the spool changeover.

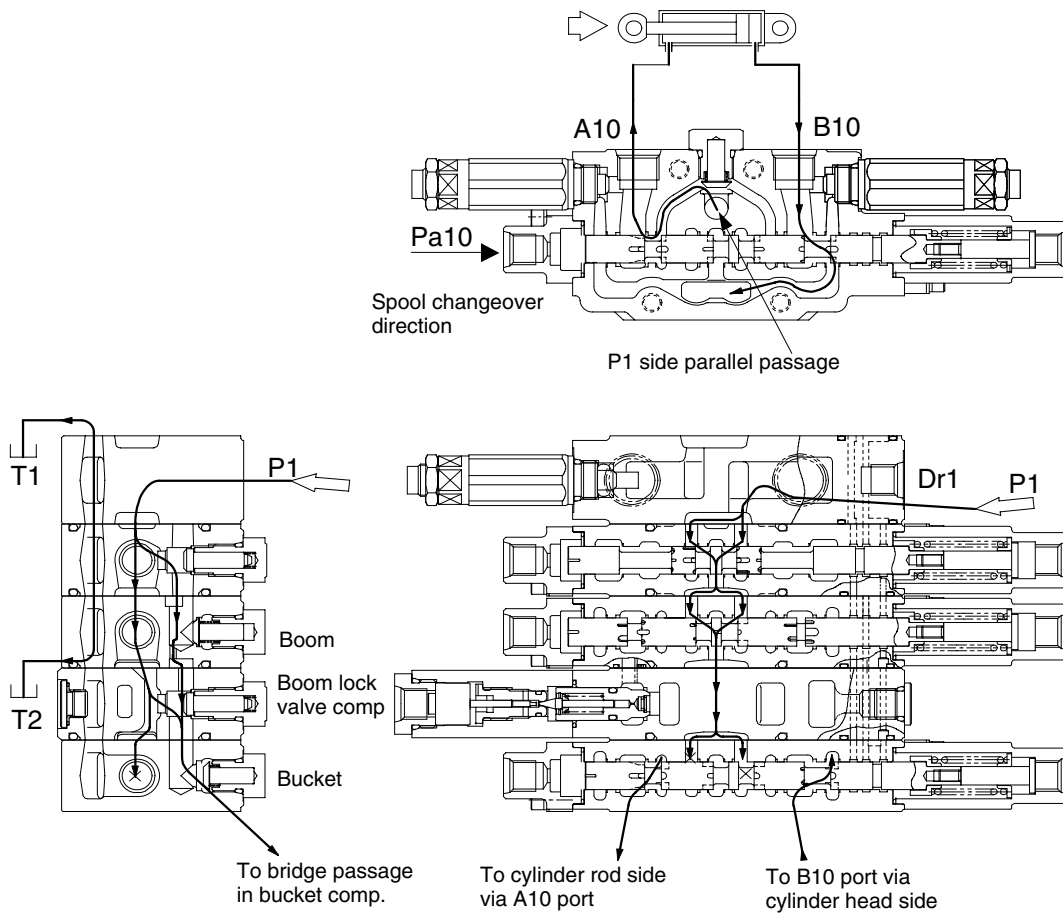

Bucket out operation

R35Z72MCV18

6) ARM OPERATION

Arm in operation

When the arm in operation is carried out, the secondary pressure from the remote control valve is applied to Pb5 port to change over the arm spool. The secondary pressure is also applied to the pilot chamber (arm in port) on the connecting section spring chamber side that has been connected through the piping. Therefore, when the operation is carried out together with the boom up operation at the same time, the connecting spool is hard to change over against the pilot pressure for arm in operation.

Since the P2 port bypass passage is shut off at the arm section after the arm spool change over, the oil flowed from P2 port flows through the travel section and a passage between travel section and arm section into the P2 side parallel passage.

Also, since the oil flowed from P3 port flows through the direction of dozer → boom swing → swing section and then into the P2 side parallel passage via the check valve in the P3 supply section, the connecting flow of P2 pump and P3 pump is supplied to the P2 side parallel passage. [Although the P3 side bypass passage is also connected to the P1 side parallel passage through the check valve in the P3 section, there is no oil flow into the P1 side as long as the P1 side sections (boom , bucket) are not operated.]

Since a passage between B5 port and the bridge passage is opened after the spool changeover, the oil flowed into the P2 side parallel passage flows through the load check valve in the arm section into B5 port via the bridge passage and then into the head side of the arm cylinder.

On the other hand, the oil returned from the rod side of the arm cylinder flows into A5 port to the tank passage that has opened with the spool's notch after the spool changeover. Then, the arm cylinder extends to make the arm in.

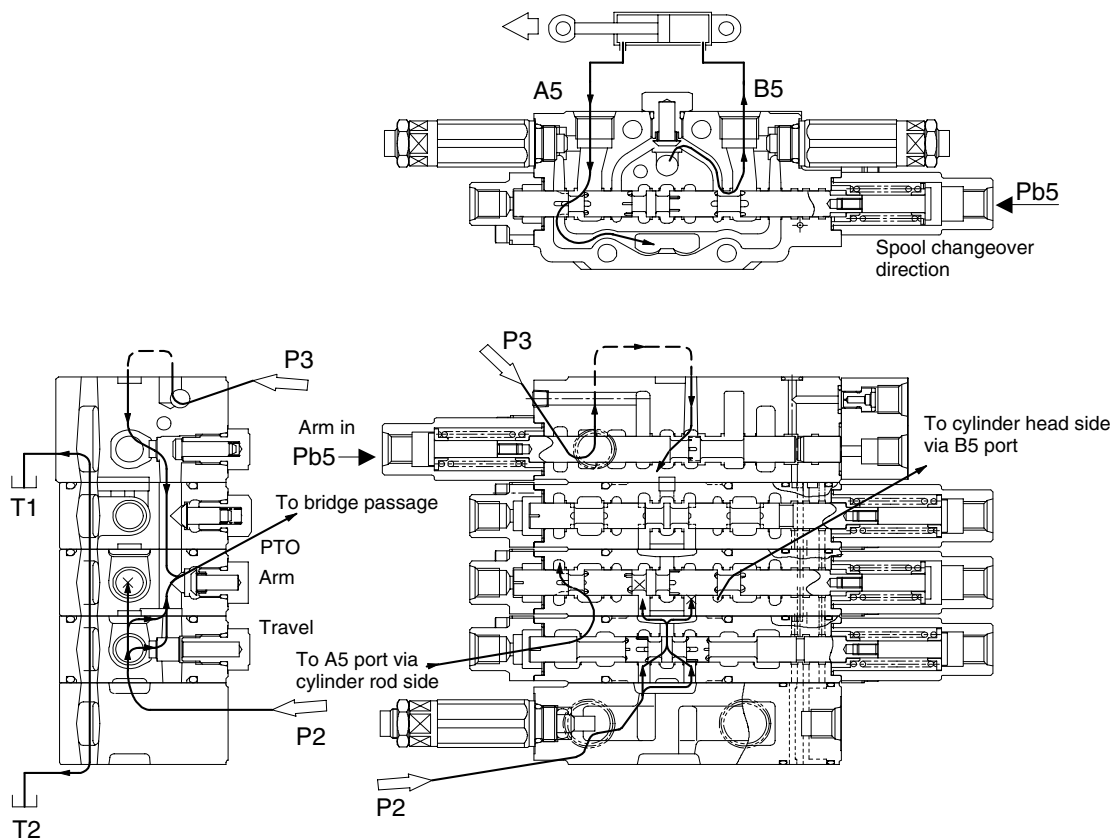

Arm in operation

R35Z72MCV19

Arm out operation

When the arm out operation is carried out, the secondary pressure from the remote control valve is applied to Pa5 port to change over the arm spool.

Since the P2 side bypass passage is shut off at the arm section after the arm spool changeover, the oil flowed from P2 port flows through the travel section and a passage between travel section and arm section into the P2 side parallel passage.

Also, since the oil flowed from P3 port flows through the direction of dozer → boom swing → swing section and then into the P2 side parallel passage via the check valve in the P3 supply section, the connecting flow of P2 pump and P3 pump is supplied to the P2 side parallel passage. [Although the P3 side bypass passage is also connected to the P1 side parallel passage through the check valve in the P3 section, there is no oil flow into the P1 side as long as the P1 side sections (boom , bucket) are not operated.]

Since a passage between A5 port and the bridge passage is opened after the spool changeover, the oil flowed into the P2 side parallel passage flows through the load check valve in the arm section into A5 port via the bridge passage and then into the rod side of the arm cylinder.

On the other hand, the oil returned from the head side of the arm cylinder flows into B5 port to the tank passage that has opened after the spool changeover. Then, the arm cylinder retracts to make the arm out.

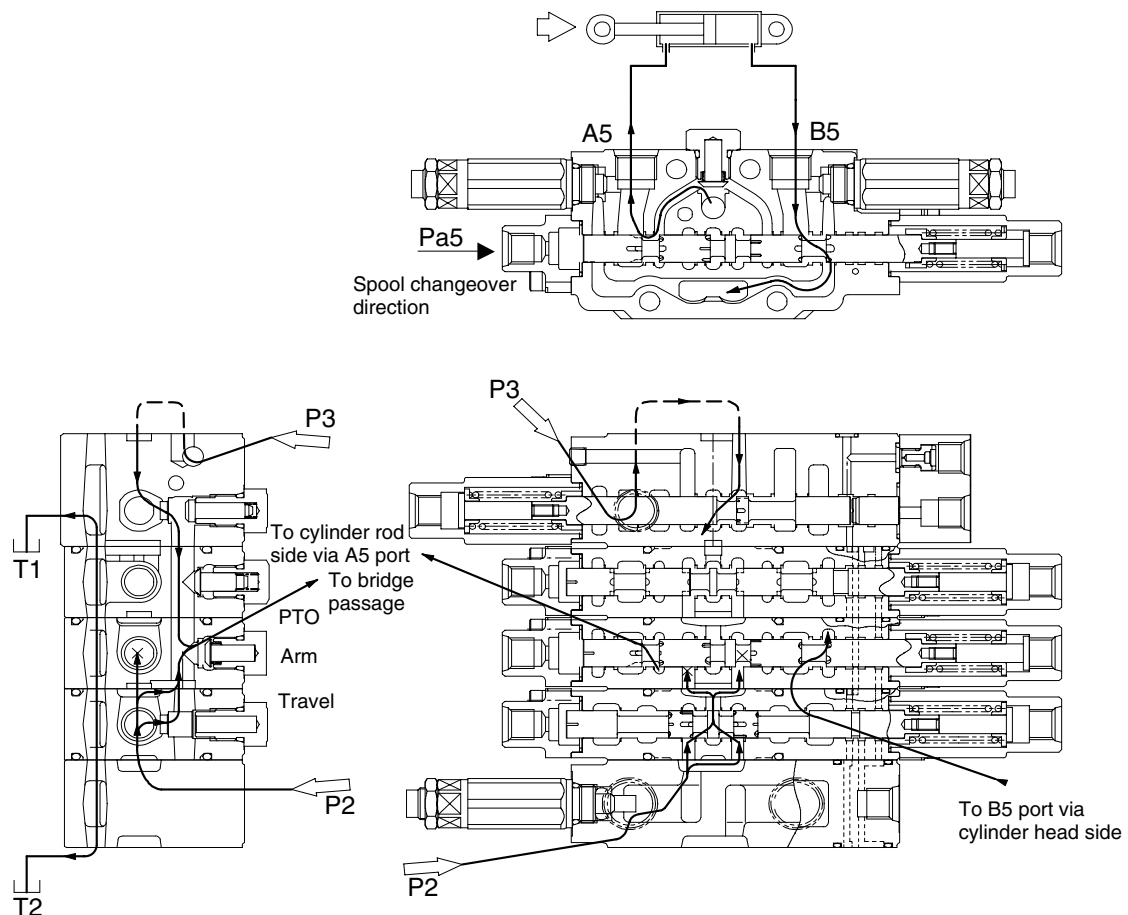

Arm out operation

R35Z72MCV20

7) PTO OPERATION

For the PTO operation, both Pa pressurization and Pb pressurization are the same on operation so that only Pa pressurization is explained as follows.

When the PTO operation (Pa4 pressurization) is carried out, the secondary pressure from the remote control valve is applied to Pa4 port to change over the PTO spool. Since the P2 side bypass passage is shut off at the PTO section after the PTO spool changeover, the oil flowed from P2 port flows through the travel section and a passage between travel section and arm section into the P2 side parallel passage.

Also, since the oil flowed from P3 port flows through the direction of dozer → boom swing → swing section and then into the P2 side parallel passage via the check valve in the P3 supply section, the connecting flow of P2 pump and P3 pump is supplied to the P2 parallel passage.

[Although the P3 side bypass passage is also connected to the P1 side parallel passage through the check valve in the P3 section, there is no oil flow into the P1 side as long as the P1 side sections (boom , bucket) are not operated.]

Since a passage between A4 port and the bridge passage is opened after the spool changeover, the oil flowed into the P2 side parallel passage flows through the load check valve in the PTO section into A4 port via the bridge passage and then into the actuator for PTO.

On the other hand, the oil returned from actuator for PTO flows into B4 port to the tank passage that has opened after the spool changeover.

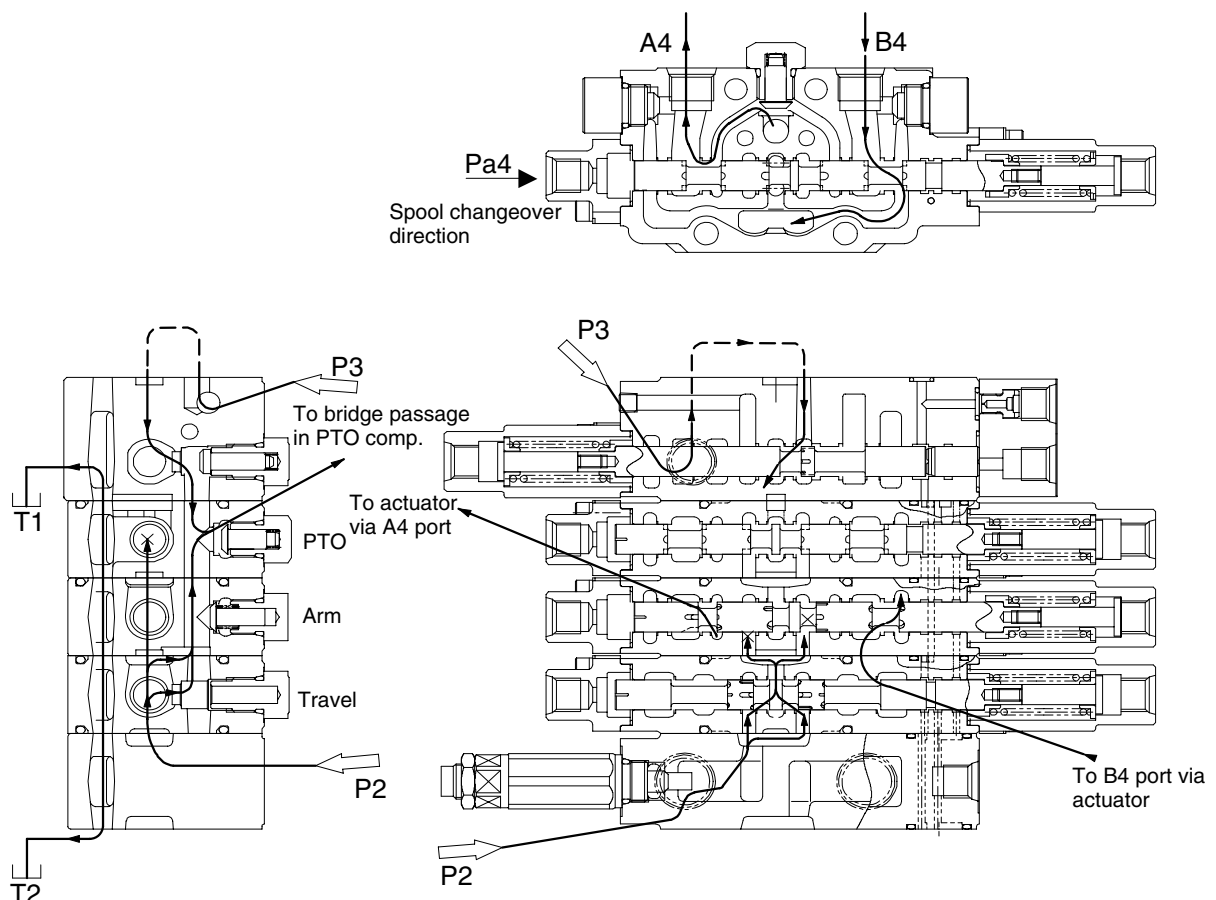

PTO operation

R35Z72MCV21

8) DOZER OPERATION

Dozer up operation

When the dozer up operation is carried out, the secondary pressure from the remote control valve is applied to Pa1 port to change over the dozer spool.

Since the P3 side bypass passage is shut off at the dozer section after the dozer spool changeover, the oil flowed from P3 port through the P3 side parallel passage flows into A1 port through the load check valve in the dozer section and the bridge passage since A1 port and the bridge passage have been opened after the spool changeover and then into the rod side of the dozer cylinder.

On the other hand, the oil returned from the head side of the dozer cylinder flows into B1 port to the tank passage that has opened after the spool changeover.

Then, the dozer cylinder retracts to raise the dozer.

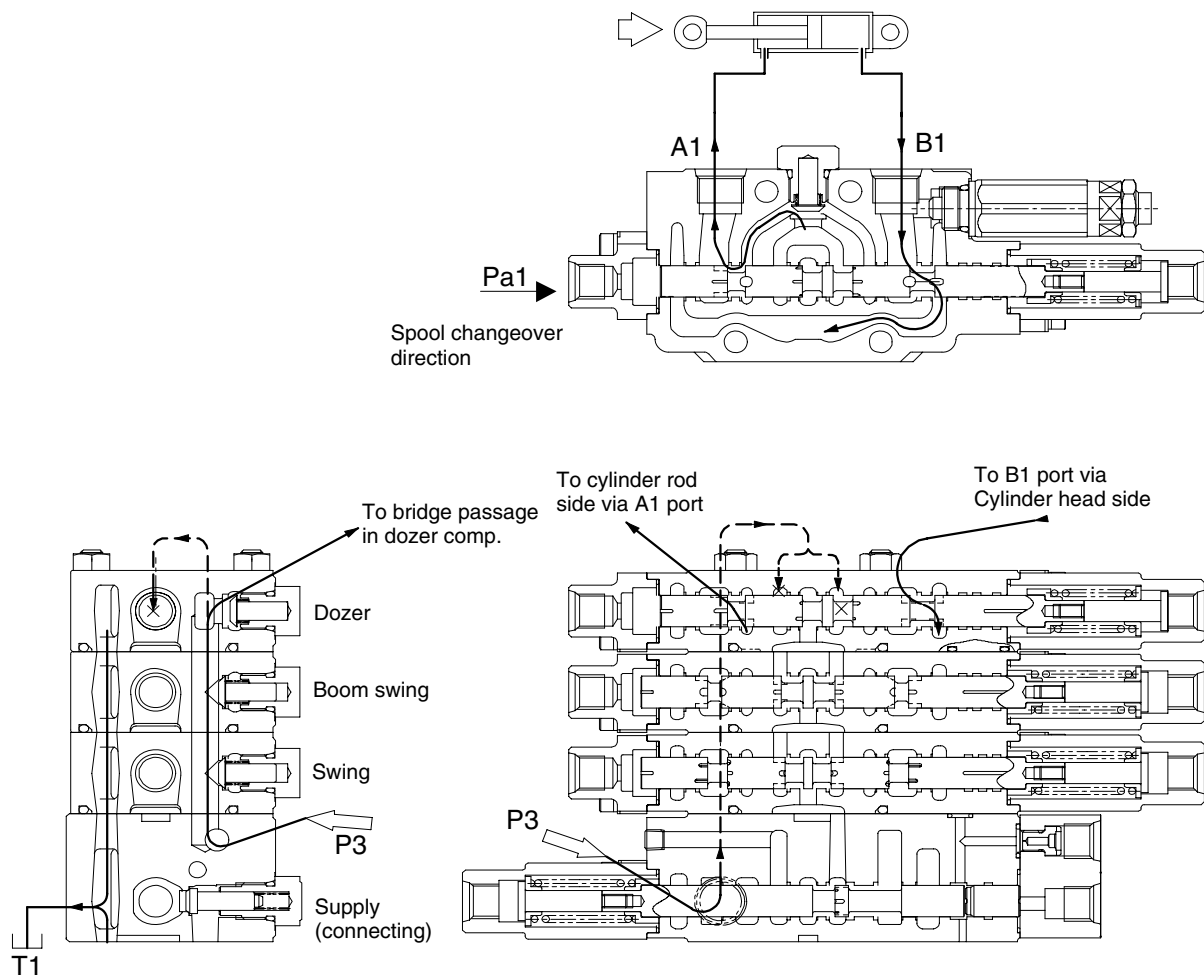

Dozer up operation

Dozer down operation

When the dozer down operation is carried out, the secondary pressure from the remote control valve is applied to Pb1 port to change over the dozer spool.

Since the P3 side bypass passage is shut off at the dozer section after the dozer spool changeover, the oil flowed from P3 port through the P3 side parallel passage flows into B1 port through the load check valve in the dozer section and the bridge passage since B1 port and the bridge passage have been opened after the spool changeover and then into the head side of the dozer cylinder.

On the other hand, the oil returned from the rod side of the dozer cylinder flows into A1 port to the tank passage that has opened with the spool's notch after the spool changeover.

Then, the dozer cylinder extends to lower the dozer.

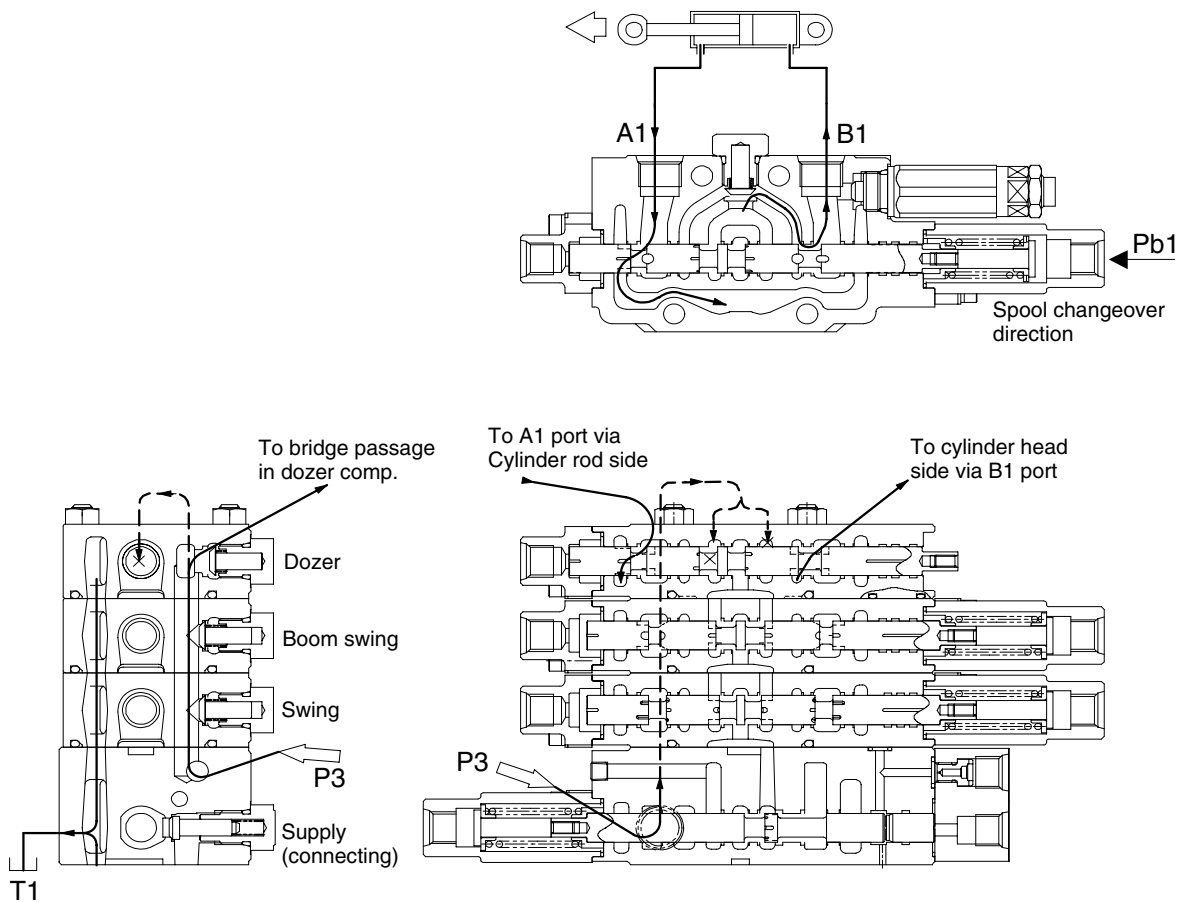

Dozer down operation

R35Z72MCV23

9) BOOM SWING OPERATION

Boom left swing operation

When the boom left swing operation is carried out, the secondary pressure from the remote control valve is applied to Pb2 port to change over the boom swing spool.

Since the P3 side bypass passage is shut off at the boom swing section after the boom swing spool changeover, the oil flowed from P3 port through the P3 side parallel passage flows into B2 port through the load check valve in the boom swing section and the bridge passage since B2 port and the bridge passage have been opened after the spool changeover and then into the rod side of the boom swing cylinder.

On the other hand, the oil returned from the head side of the boom swing cylinder flows into A2 port to the tank passage that has opened with the spool's notch after the spool changeover.

Then, the boom swing cylinder retracts to swing the attachment left.

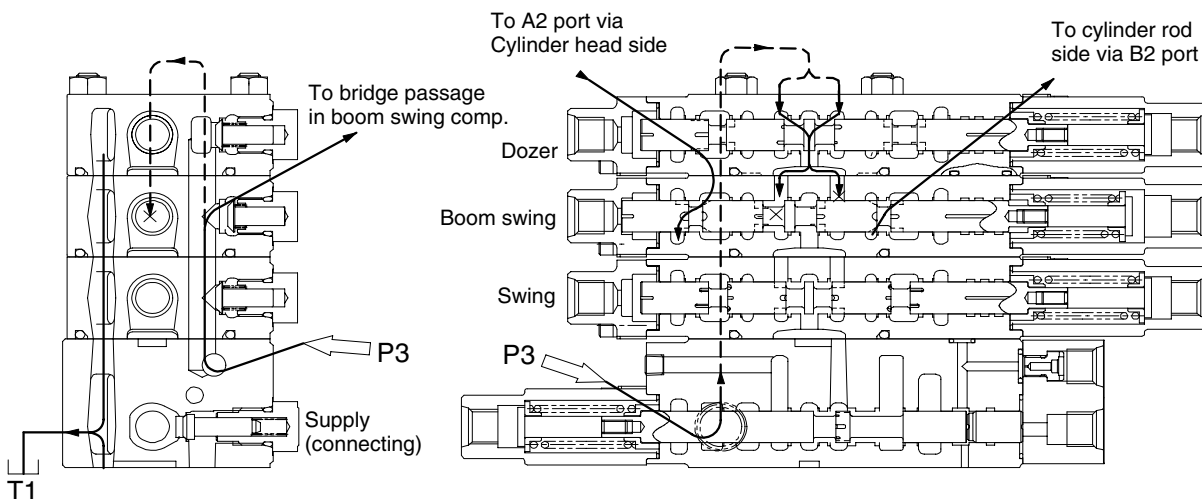
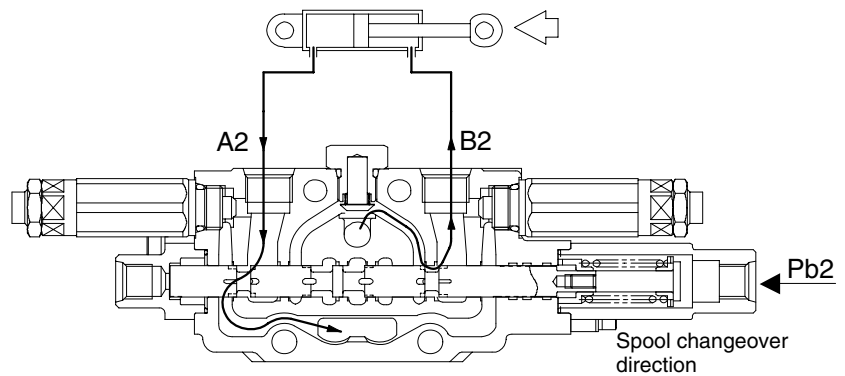

Boom left swing operation

R35Z72MCV24

Boom right swing operation

When the boom right swing operation is carried out, the secondary pressure from the remote control valve is applied to Pa2 port to change over the boom swing spool.

Since the P3 side bypass passage is shut off at the boom swing section after the boom swing spool changeover, the oil flowed from P3 port through the P3 side parallel passage flows into A2 port through the load check valve in the boom swing section and the bridge passage since A2 port and the bridge passage have been opened after the spool changeover and then into the head side of the boom swing cylinder.

On the other hand, the oil returned from the rod side of the boom swing cylinder flows into B2 port to the tank passage that has opened with the spool's notch after the spool changeover.

Then, the boom swing cylinder extends to swing the attachment right.

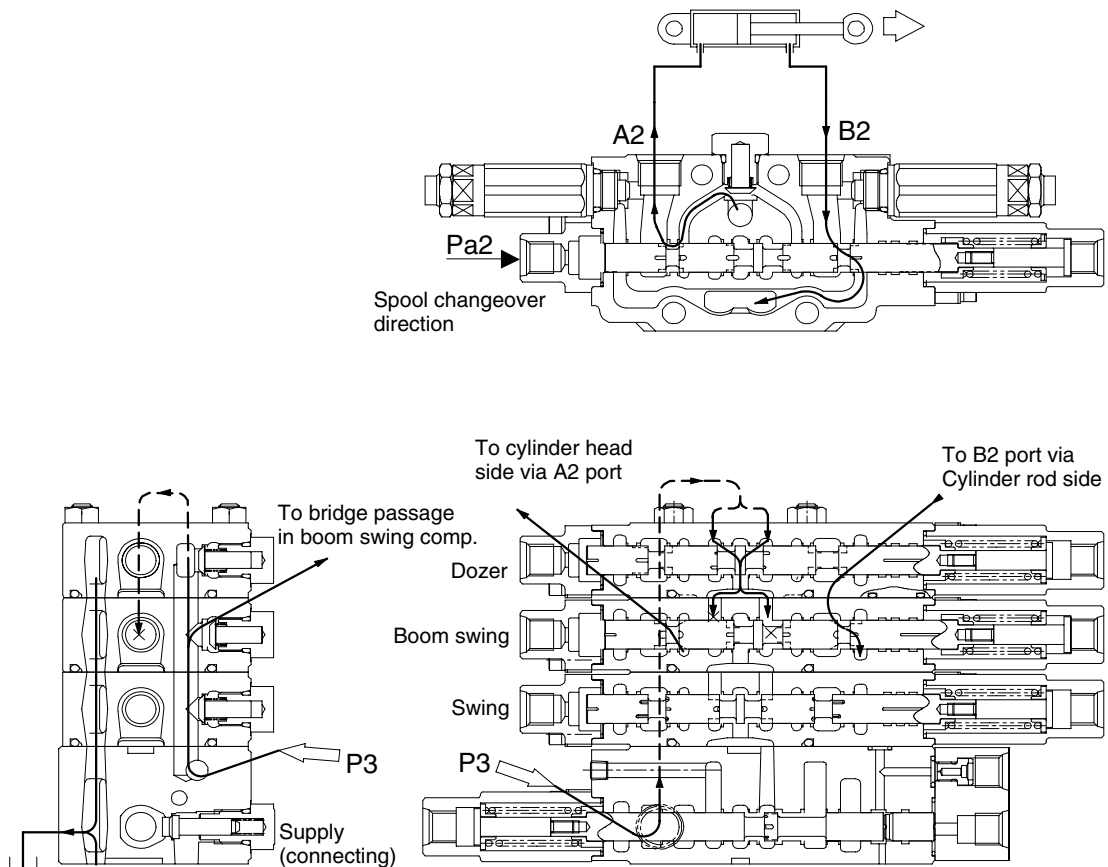

T1

Boom right swing operation

R35Z72MCV25

(10) SWING OPERATION

For the swing operation, both Pa pressurization and Pb pressurization are the same on operation so that only Pa pressurization is explained as follows.

When the right swing operation is carried out, the secondary pressure from the remote control valve is applied to Pa3 port to change over the swing spool.

Since the P3 side bypass passage is shut off at the swing section after the swing spool changeover, the oil flowed from P3 port through the P3 side parallel passage flows into A3 port through the load check valve in the swing section and the bridge passage since A3 port and the bridge passage have been opened after the spool changeover and then into the swing motor.

On the other hand, the oil returned from the swing motor flows into B3 port to the tank passage that has opened with the spool's notch after the spool changeover.

Then, the upper swing body swings right.

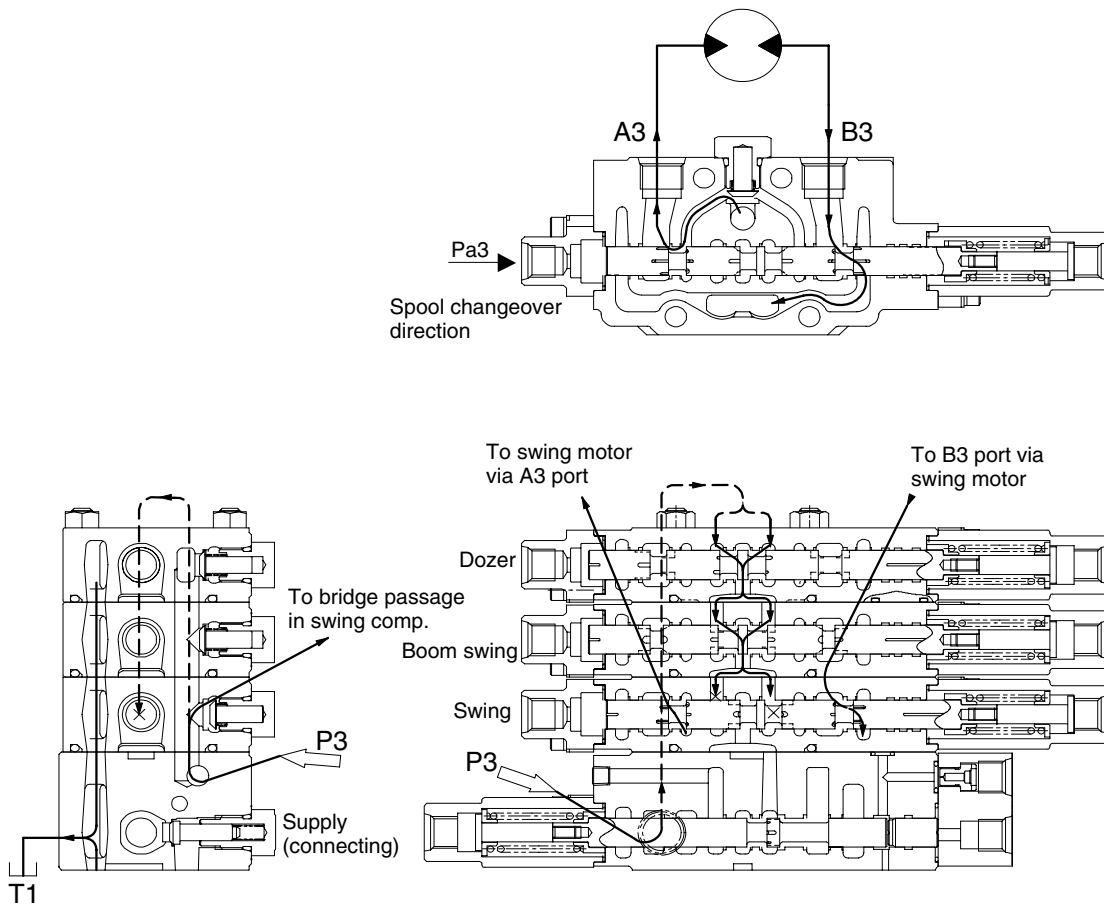

Right swing operation

(11) COMBINED CONTROL OPERATION ①

Boom up + Arm in + bucket

When the above combined control is carried out, the secondary pressure from the remote control valve is applied to each spool to change over them. Since the secondary pressure for arm in operation is also applied to the pilot chamber on the connecting section spring chamber side according to the piping, the connecting spool operates against the secondary pressure developed from boom up operation and arm in operation.

(Boom up operation secondary pressure - Arm in operation secondary pressure = connecting spool changeover pressure)

When all the above combined operations are carried out in full lever operation (full changeover), the oil supplied from P1 pump is supplied to the boom and bucket and the oil from P2 pump to the arm. Since the connecting spool changeover pressure becomes "0" as mentioned above, the connecting spool cannot change over and the oil from P3 pump flows to the P1 and P2 side parallel passages through the connecting section. Accordingly, much oil flows to the arm side normally because of its low working load.

In this condition, since gradually restricting the arm in operation (returning the lever) causes the secondary pressure for arm in operation to decrease, the connecting spool changeover pressure to increase, the connecting spool to start changing over, and the passage to the arm side to be narrowed, the oil supplied from P3 pump flows abundantly into the P1 side (Boom, bucket).

As mentioned above, the oil supplied from P3 pump flows suitably into each attachment according to the control input during the above combined control, resulting in a well-balanced and efficient working speed.

Besides, since the oil flow to the bucket whose working load is less than the boom is restricted with an orifice (the orifice of boom priority) provided before the bucket section in the P1 side parallel passage, much oil flows into the boom section. As a result, the working speed balance between both attachments is maintained during the combined operation of boom and bucket.

P3 side (Connecting side) circuit

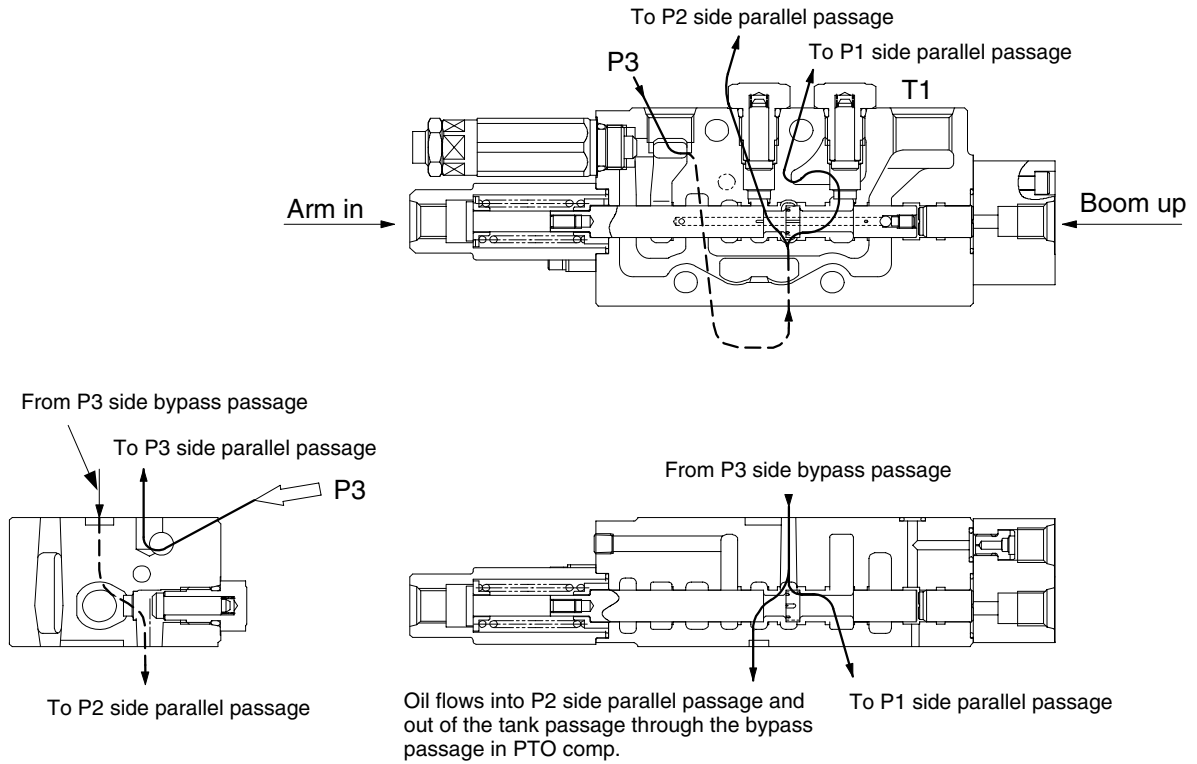

P1 side circuit(the orifice of boom priority)

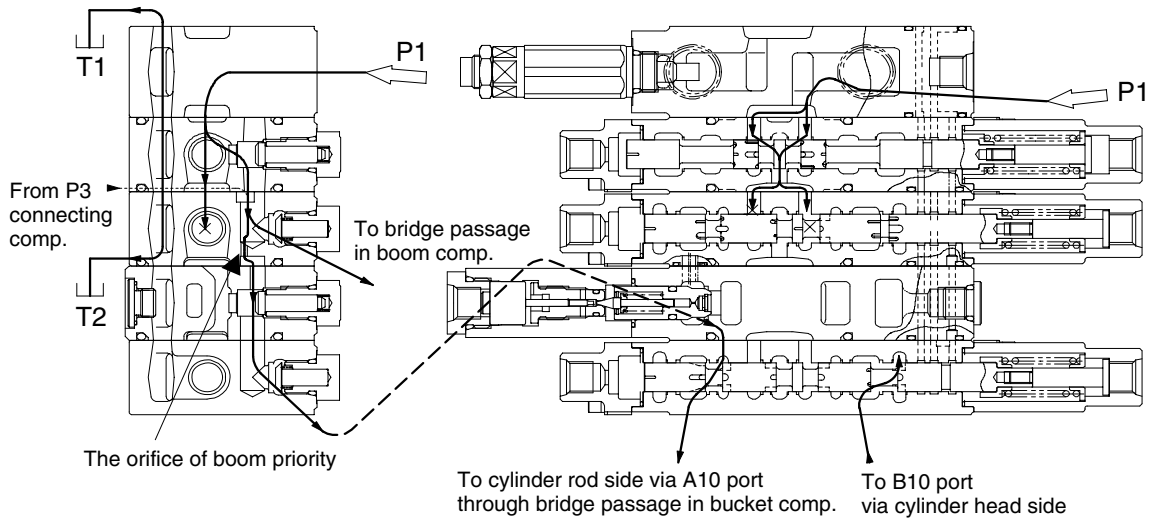

Oil flow during combined operation

R35Z72MCV27

(12) COMBINED CONTROL OPERATION ②

Both travels + bucket

When the both travels operation is carried out together with the bucket operation at the same time, the oil flowed from Pp1 port flows through the orifice passage and into the travel independent signal passage; both travels and the bucket spool changeover make a passage to the drain port shut off.

Then, the travel independent passage becomes the same pressure as Pp1 port pressure (pilot primary pressure).

When the travel independent passage becomes Pp1 pressure, the Pp1 pressure is applied to the connecting spool to change over the connecting spool.

Since the bypass passage from P3 to P2 side, which is a passage to the tank, is restricted, the oil from P3 side flows into the P1 side parallel passage that is connected through a check valve.

With this circuit arrangement, the bucket section is supplied with pressure oil from P3 during both travels operation, the simultaneous operation becomes possible.

Besides, since each of P1 and P2 is used independently during both travels and only P3 is used for bucket operation, stable travel is possible to continue even if there is change in the bucket load.

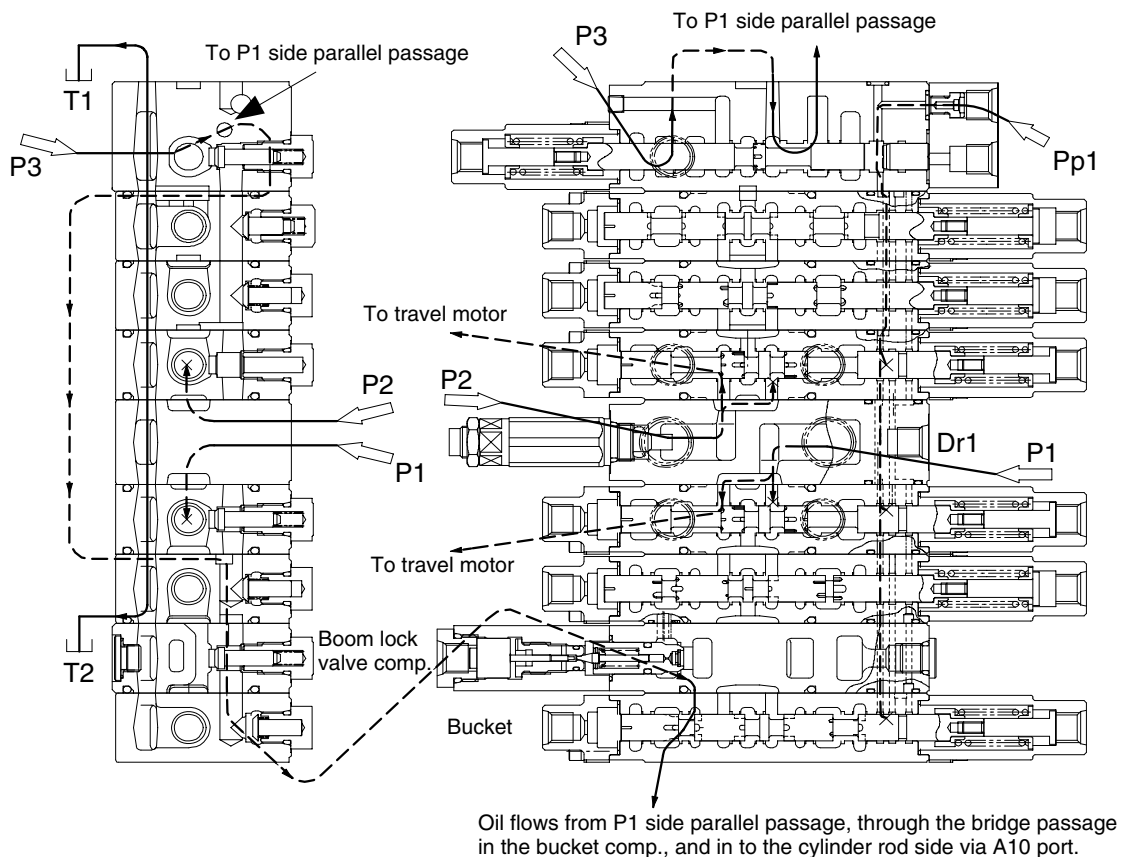

Travel independence operation

R35Z72MCV28

(13) MAIN AND PORT RELIEF VALVE OPERATION

Main relief valve operation

Main relief valves (MRV) are different in the uses for P1/P2 and P3; however, their structures and operation are the same.

- ① Pressure oil flows through the inside of the piston built in the pressure regulating valve (poppet-main V') and the orifice B and then into the internal chamber A until it is filled up. The filled up pressure causes both of the pressure regulating valve and the socket and body seat to be seated securely.

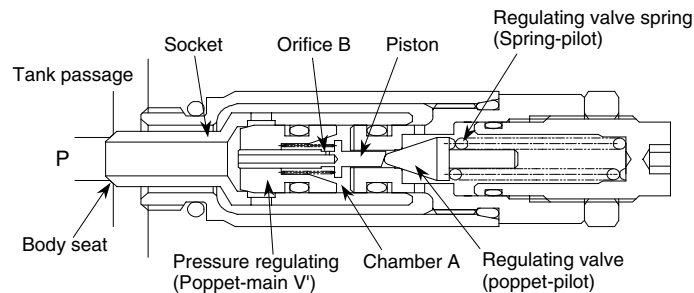

MRV operation (1)

R35Z72MCV29

- ② When the oil pressure at port P increases up to the setting pressure of regulating valve spring, the pressure oil is applied to the regulating valve via the piston to open the regulating valve. Then, the pressure oil flows through a passage in the direction of piston inside → orifice B → chamber A → circular orifice C → Drill hole D and the external of socket and then into the tank passage.

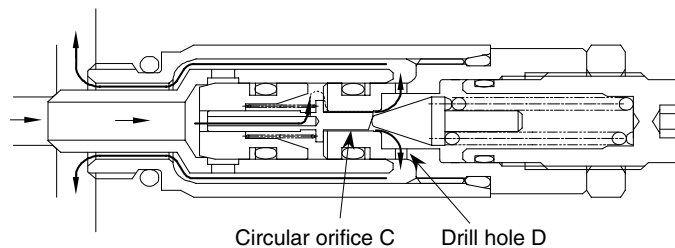

MRV operation (2)

R35Z72MCV30

- ③ Since the pressure inside the chamber A decreases when the regulating valve is opened, which causes the pressure regulating valve to open to let the pressure oil port P flows into the tank passage through drill hole E.

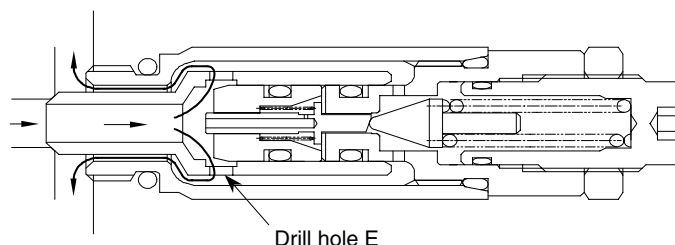

MRV operation (3)

R35Z72MCV31

- ④ Also, since the regulating valve is pressed to the seat by regulating valve spring when the pressure at port P decreases below the setting pressure of regulating valve spring, the pressure inside chamber A becomes the same as the pressure at port P to cause the pressure regulating valve to be pressed to the seat, resulting in the original condition (①).

Overload relief valve (ORV) operation ①

- ① Pressure oil flows through the inside of the piston built in the pressure regulating valve (poppet-main V') and the orifice B and then into the internal chamber A until it is filled up. The filled up pressure causes both of the pressure regulating valve and socket and body seat to be seated securely.

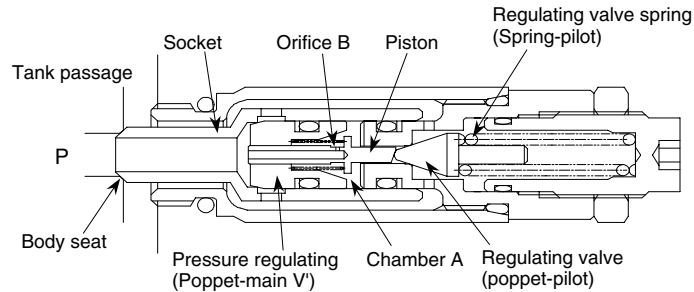

ORV operation (1)

R35Z72MCV32

- ② When the oil pressure at port P increases up to the setting pressure of regulating valve spring, the pressure oil is applied to the regulating valve via the piston to open the regulating valve. Then, the pressure oil flows through a passage in the direction of piston inside → orifice B → chamber A → circular orifice C → Drill hole D and the external of socket and then into the tank passage.

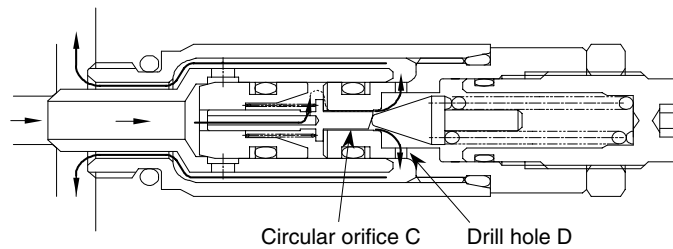

ORV operation (2)

R35Z72MCV33

- ③ Since the pressure inside the chamber A decreases when the regulating valve is opened, which causes the pressure regulating valve to open to let the pressure oil port P flows into the tank passage through drill hole E.

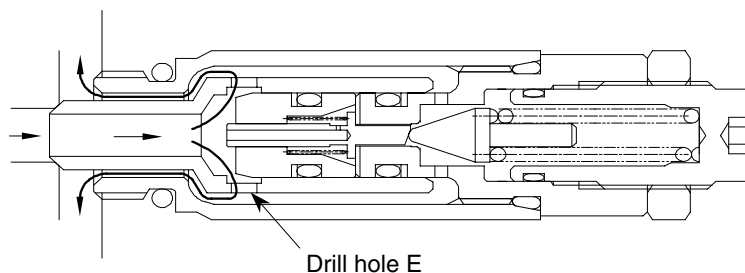

ORV operation (3)

R35Z72MCV34

- ④ Also, since the regulating valve is pressed to the seat by regulating valve spring when the pressure at port P decreases below the setting pressure of regulating valve spring, the pressure inside chamber A becomes the same as the pressure at port P to cause the pressure regulating valve to be pressed to the seat, resulting in the original condition (①).

Overload relief valve (ORV) operation ② 【Operation during suction】

If there is negative pressure at port P (or the tank passage pressure is higher than P pressure), the socket is applied with press and open force. Then, the opening between body seat and socket increases to cause the oil to flow into port P from the tank passage, filling up the space.

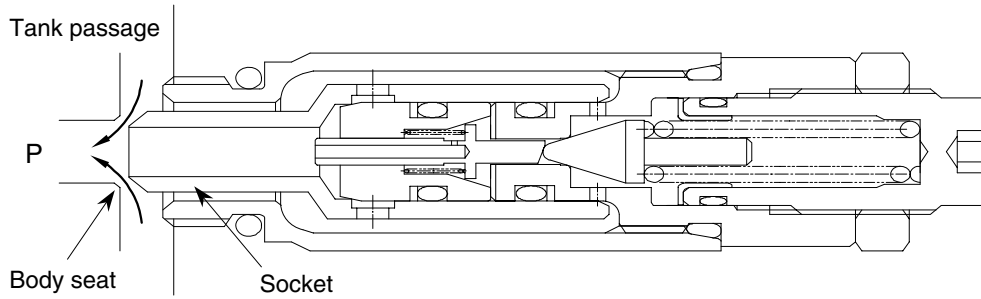

ORV operation (during suction)

R35Z72MCV35