

## SECTION 2 STRUCTURE AND FUNCTION

Group 1 Pump Device .....	2-1
Group 2 Main Control Valve .....	2-8
Group 3 Swing Device .....	2-37
Group 4 Travel Device .....	2-60
Group 5 RCV Lever .....	2-67

# SECTION 2 STRUCTURE AND FUNCTION

## GROUP 1 HYDRAULIC PUMP

### 1. GENERAL

This is a variable displacement double-piston pump for discharge with equal displacements from one cylinder block. This pump is so compact as to appear a single pump though this is actually a double pump.

Because this pump has one swash plate, the tilting angle is the same for two pumps. Tilting of the pump changes in response to the total pressure of A1 + A2. Namely, the output is controlled to the constant value so that the relationship between the discharge pressure and flow rate Q becomes constant,  $(A1 + A2) * Q = \text{Constant}$ .

The third pump and pilot pump can be connected to the same shaft via a coupling.

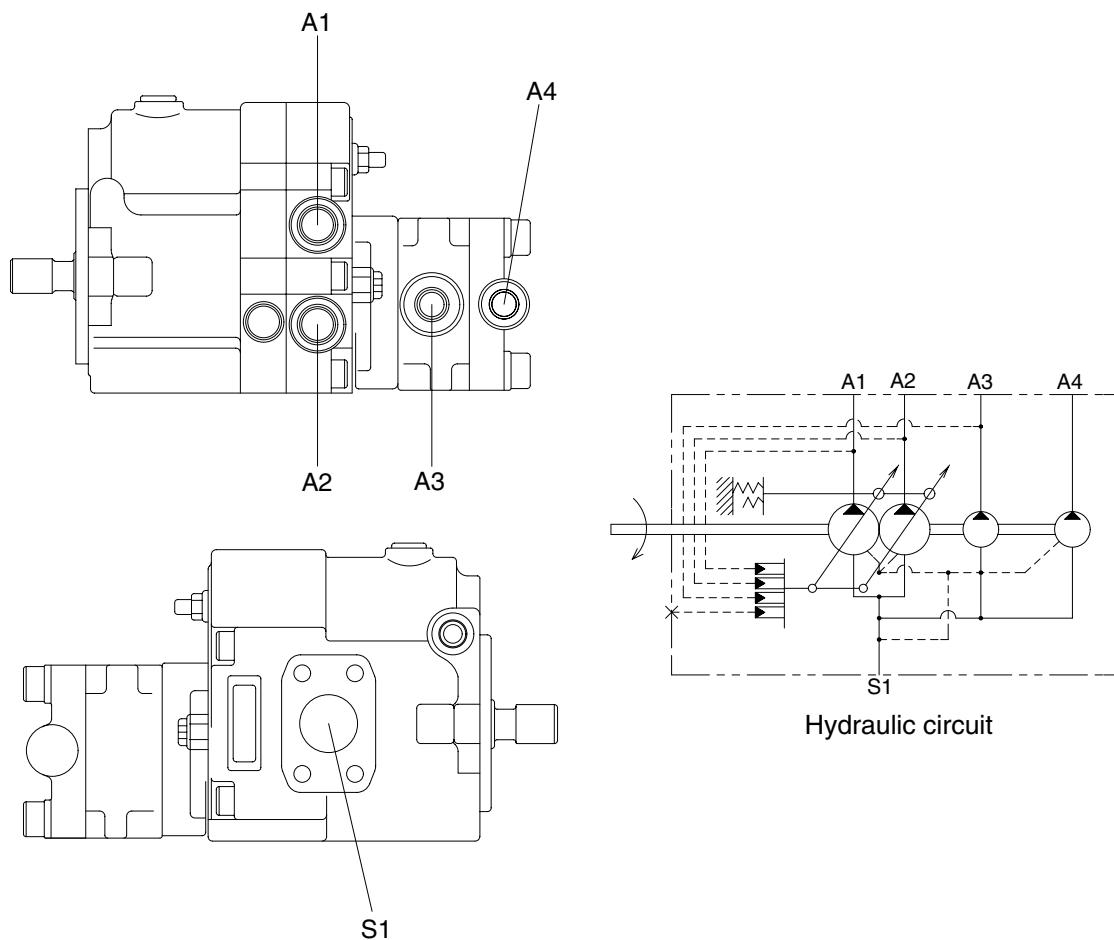

R27Z92MP01

### Description of the ports

Port	Port name	Port size
S1	Suction port	SAE 1 1/4
A1, A2	Discharge port	PF 1/2
A3, A4	Discharge port	PF 3/8

## 2. MAJOR COMPONENTS AND FUNCTIONS

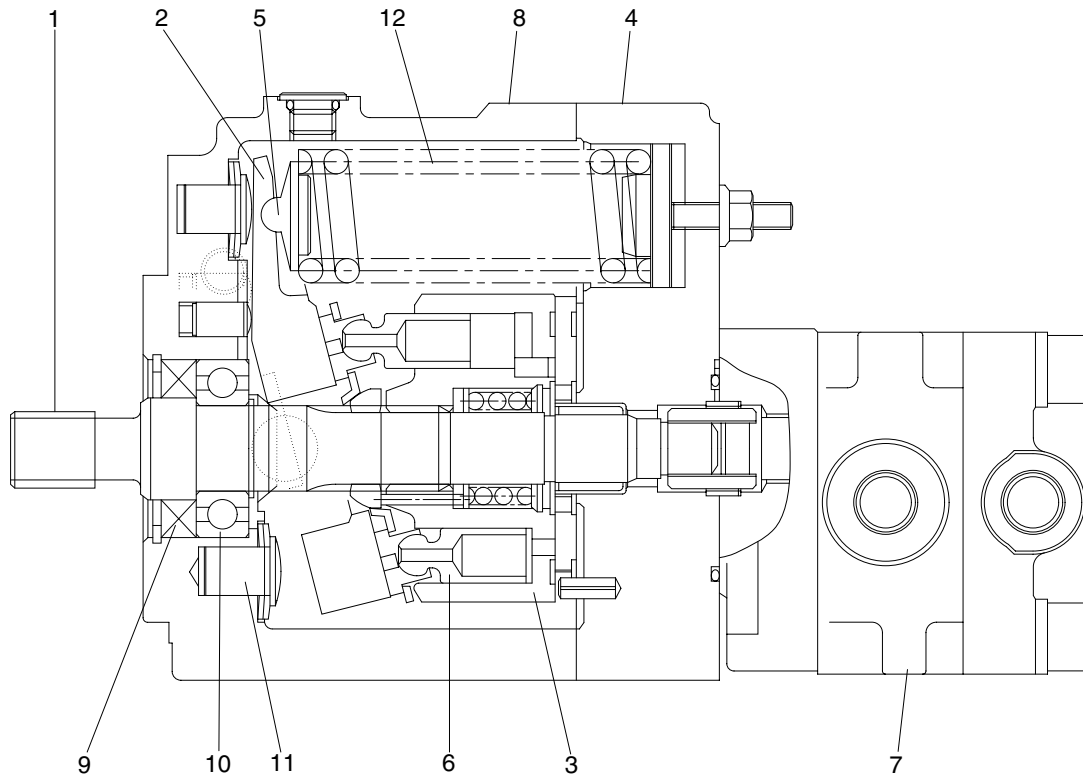

R27Z92MP03

- |   |                      |    |                  |
|---|----------------------|----|------------------|
| 1 | Drive shaft assembly | 7  | Gear pump        |
| 2 | Swash plate assembly | 8  | Housing          |
| 3 | Cylinder barrel      | 9  | Oil seal         |
| 4 | Port plate assembly  | 10 | Bearing          |
| 5 | Spring seat assembly | 11 | Stopper assembly |
| 6 | Piston               | 12 | Spring           |

This is a variable displacement double-piston pump for discharge with two equal displacements from one cylinder block. Because this is one cylinder barrel, there is only one suction port.

The oil is divided into two equal flows by the control plate in the cover and directed to two discharge ports provided in the cover.

The discharge pressure directed to the piston tilts the hanger by overcoming the spring force.

Since the piston stroke changes according to the tilting angle of the hanger, the flow can be changed.

The simultaneous tilting angle constant-output control method is employed.

The pilot pump can be connected to the same shaft via a coupling.

## 1) PRINCIPLE OF OPERATION

### (1) Function of pump

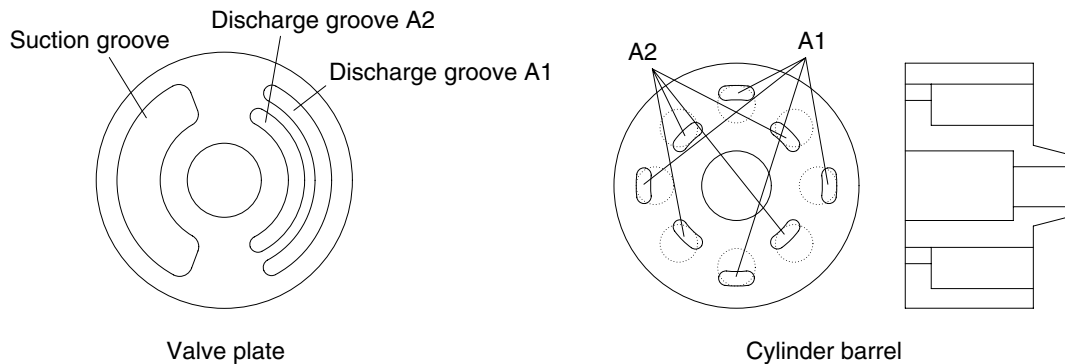

Figure 1 Working principle of PVD pump

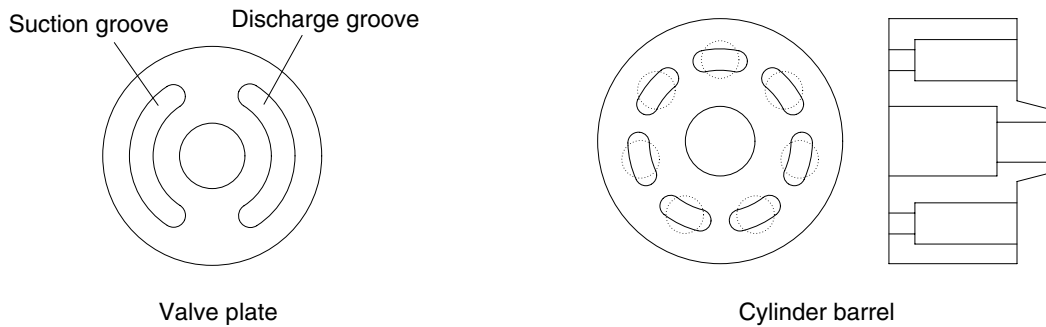

Figure 2 Working principle of Conventional type

R27Z92MP05

This pump adopts a new method using even numbered pistons to make functions of two same volume pumps available in one casing of a swash plate type variable volume piston pump.

Conventional valve plate has one suction groove and one discharge groove respectively as shown in figure 2. But this method adopts one common suction groove and two discharge grooves on the outer side (A1) and the inner side (A2) as shown in figure 1, the piston room in the cylinder barrel opens to either the outer side (A1) or the inner side (A2) discharge groove of the valve plate alternately, and the discharges are performed independently on the inner side and the outer side.

Since this model has even numbered pistons, same No of pistons open to the outer side and the inner side of the valve plate. All pistons are of same swash plate, so the discharges from the outer side (A1) and the inner side (A2) are equal.

Also, since only one swash plate is used, the discharges from A1 and A2 ports changes equally when the swash plate angle of rake changes in variable controls. So, there is no difference between the two discharges.

## 2) CONTROL FUNCTIONS

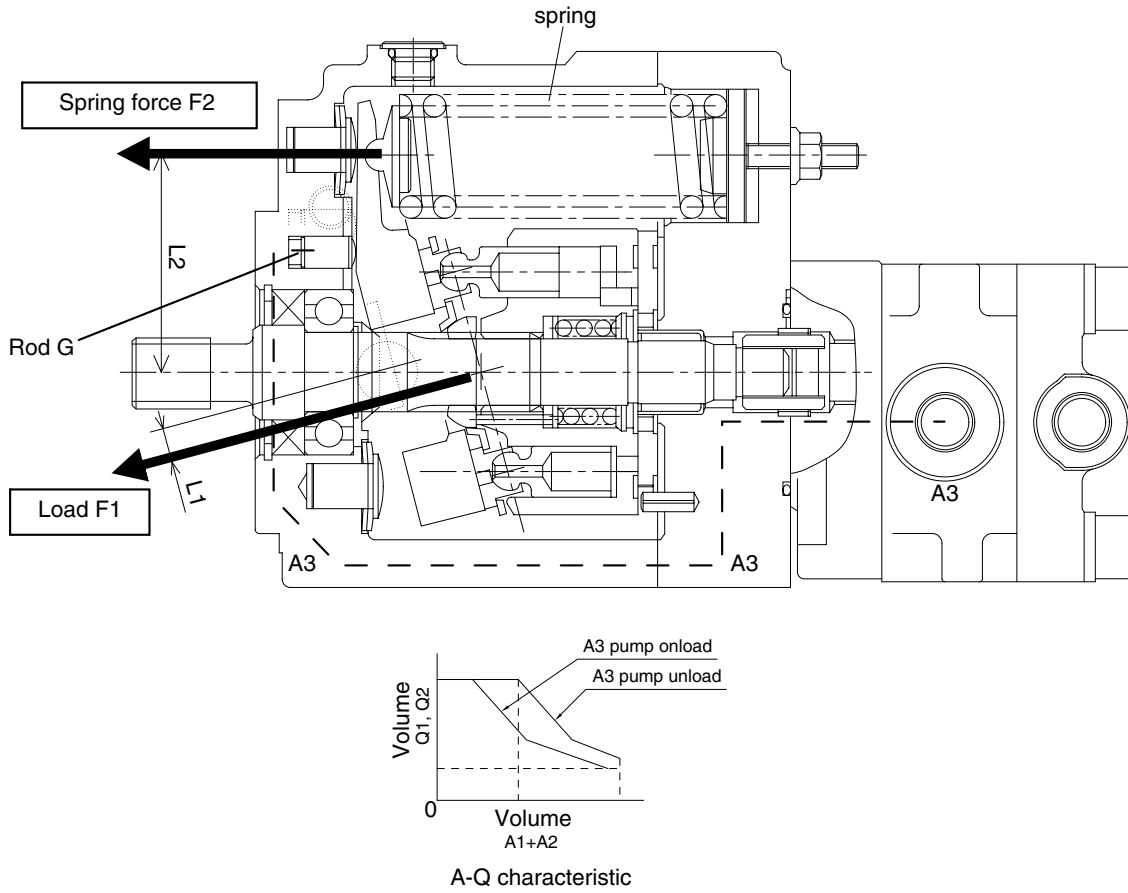

R27Z92MP04

### (1) Constant horse power variable structure

The pump output flow rate is variable depending on an angle of the swash plate which is controlled according to the pump output pressure. This control enables the pump consumption horse power to be sustained at the maximum. The tilt point of the swash plate is the balls located behind the swash plate. The load  $F_1$  from the pistons is in the direction shown in the illustration and generates a clockwise moment against the swash plate. Against this force the spring (force  $F_2$ ) is located in the opposite direction to keep the horse power constant and set at the appointed load. As the pressure increases, the above clockwise moment increases, and when it overcomes the counter-clockwise moment created by the spring force, the spring is sagged and the swash plate angle gets smaller. Then the output flow rate is reduced to keep the horse power constant. This prevents engine stall and the engine horse power can be utilized at the maximum.

### (2) Power shift mode (Reduced horse power control by A3 pressure)

This control keeps the maximum value of the pump consumption horse power including the third pump (gear pump) constant. When the A3 (gear pump) pressure acts on the rod G, a clockwise moment proportion to the pressure acts on the swash plate and the A-Q characteristic shifts so that the total pump consumption horse power including the gear pump horse power is kept constant.

### 3) CONTROL / ADJUSTMENT PROCEDURE

- (1) Loosen the hexagonal nut.
- (2) Tighten or loosen the adjusting screw to set the power shifting line.

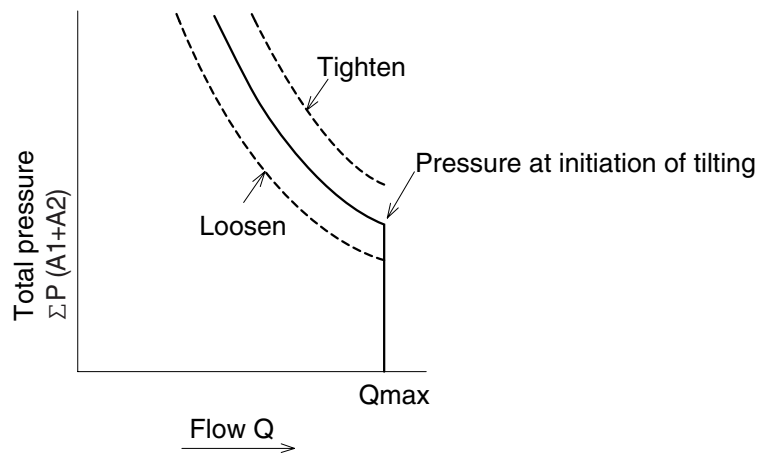
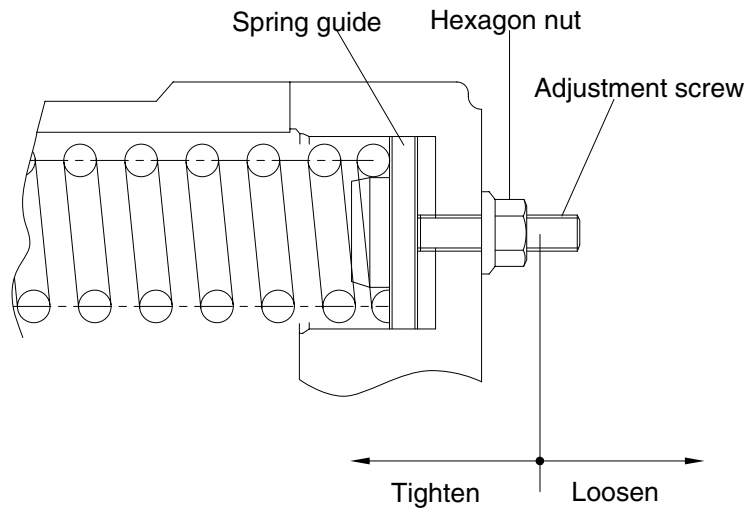

R27Z92MP07

### 3. ADJUSTMENT

This hydraulic pump has been set and inspected according to specified input power and control. Readjustment of all the adjusting portions may lead to the loss of functions specified for each control and the pump proper may be excluded from the scope of guarantee. Never attempt operating the adjusting screw, etc.

### 4. INSTALLATION

- (1) Install the pump so that the input shaft becomes horizontal.
- (2) Install the pump in a position lower than the lowest oil level in the tank to allow continuous flow of the oil into the pump.
- (3) Since the pump is installed directly to the diesel engine, always use a flexible hose. Install the suction pipe firmly to prevent suction of an air.
- (4) Use the high-pressure type flexible hoses for the discharge ports A1~A2.
- (5) After installation, fill the pump housing with the hydraulic oil.
- (6) Do not direct the external drain piping from within the oil.

### 5. DRIVE

- (1) Use a flexible coupling for connection to the motor.
- (2) Insert the coupling firmly onto the input shaft. Do not hammer the coupling during insertion.
- (3) The input shaft must rotate clockwise when viewed from the shaft end.

### 6. HYDRAULIC OIL

The hydraulic oil to be used must be a general petroleum, hydraulic oil or wear-resistant hydraulic oil (ISO 3448, VG 32~56 or equivalent).

The applicable viscosity range is as follows :

Maximum allowable viscosity : 1000 mm<sup>2</sup>/s

Minimum allowable viscosity : 10 mm<sup>2</sup>/s

Recommended viscosity range : 15 ~ 36 mm<sup>2</sup>/s

### 7. STARTING PROCEDURE

※ **Before start up, check the following points and observe the cautions :**

- (1) Check if the tank has been washed clean.
- (2) Check if the piping is clean and installed in such a manner as to prevent stress on the pump.
- (3) Check if the piping is connected correctly according to the piping (circuit) diagram.
- (4) Check if the joint and flange are correctly tightened.
- (5) Check if the joint between the motor and pump is correctly installed.
- (6) Check if the motor rotation direction agrees with the pump rotation direction.
- (7) Check if the specific hydraulic oil is supplied through the filter and filled in the tank to the specified position of the oil level gauge.
- (8) Check if the filter has the specified filtration accuracy (10 μm or less).
- (9) Check if the filter has been installed correctly relative to the flow direction.
- (10) Check if the pump housing is filled with oil.
- (11) Check if the control valve is set to the bypass position.
- (12) Start the motor. If necessary, carry out warm-up operation at low speed.
- (13) Check, without any load on the system, if the actuator operates correctly.

- (14) When the motor has reached the operation speed, check the operation while applying the load to the actuator.
- (15) Check the monitoring or measuring instrument if installed.
- (16) Check the noise level.
- (17) Check the oil level in the tank. Supply the oil. If required.
- (18) Check the setting of the pressure control valve while applying the load to the actuator.
- (19) Check the parts for any leakage.
- (20) Stop the motor.
- (21) Retighten all the bolts and plugs even when they have proved to be free from Leakage.  
(Be sure to remove the pressure from the circuit before retightening.)
- (22) Check the oil level in the tank.
- (23) Check if the pump and actuator function correctly.
- (24) Irregular operation of the actuator indicates that an air is left still in the circuit. When the air is bled completely from the circuit, all the parts operate smoothly without any irregular movement and there is no bubble in the oil of the tank.
- (25) Check the oil temperature.
- (26) Stop the motor.
- (27) Check the filter if the element is fouled.
- (28) If the element is heavily fouled, carry out flashing in the circuit.

※ **To prevent damage to the pump, be sure to observe the following cautions during the operation which may allow entry of the actuator, hydraulic oil change, etc :**

- (1) After oil supply, fill the pump housing with the hydraulic oil.
- (2) Start the pump with the speed of 1000 rpm or less and take care not to allow the oil level to lower below the specified level of the oil level gauge.
- (3) When bleeding an air from the hydraulic circuit, keep the motor speed at 1000 rpm or less. Operate each actuator for three or more cycles and carry out idling for 5 minutes or more.