

GROUP 4 TRAVEL DEVICE

1. CONSTRUCTION

Travel device consists travel motor and gear box.

Travel motor includes brake valve, parking brake and high/low speed changeover mechanism.

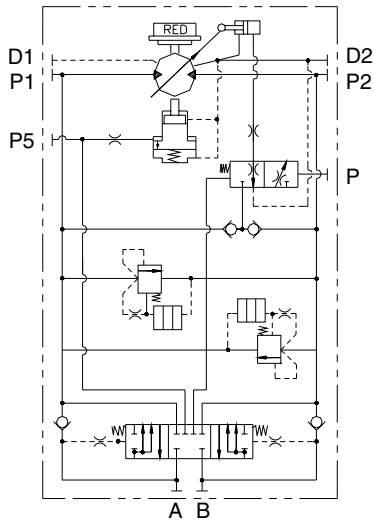
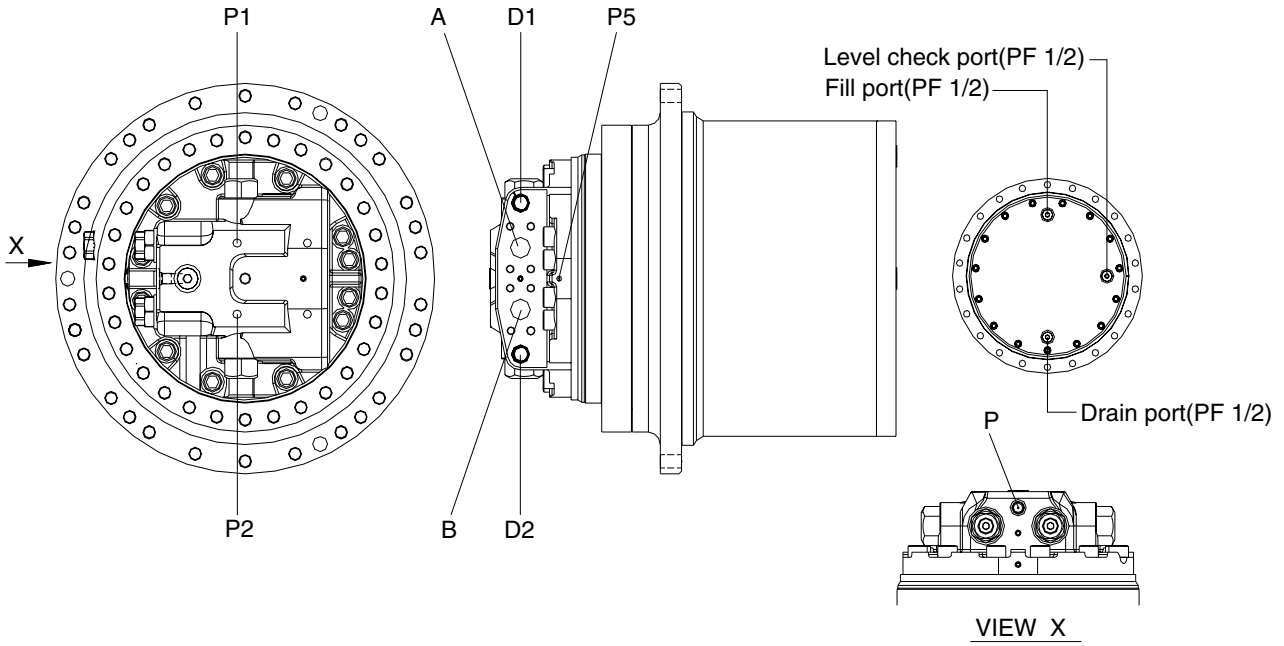

Hydraulic circuit

| Port | Port name | Port size |
|--------|----------------------------|----------------|
| A | Main port | SAE 5000psi 1" |
| B | Main port | SAE 5000psi 1" |
| P1, P2 | Gauge port | PT 1/4 |
| D1, D2 | Drain port | PT 1/2 |
| P5 | Parking brake release port | PT 1/8 |

25092TM01

1) BASIC STRUCTURE

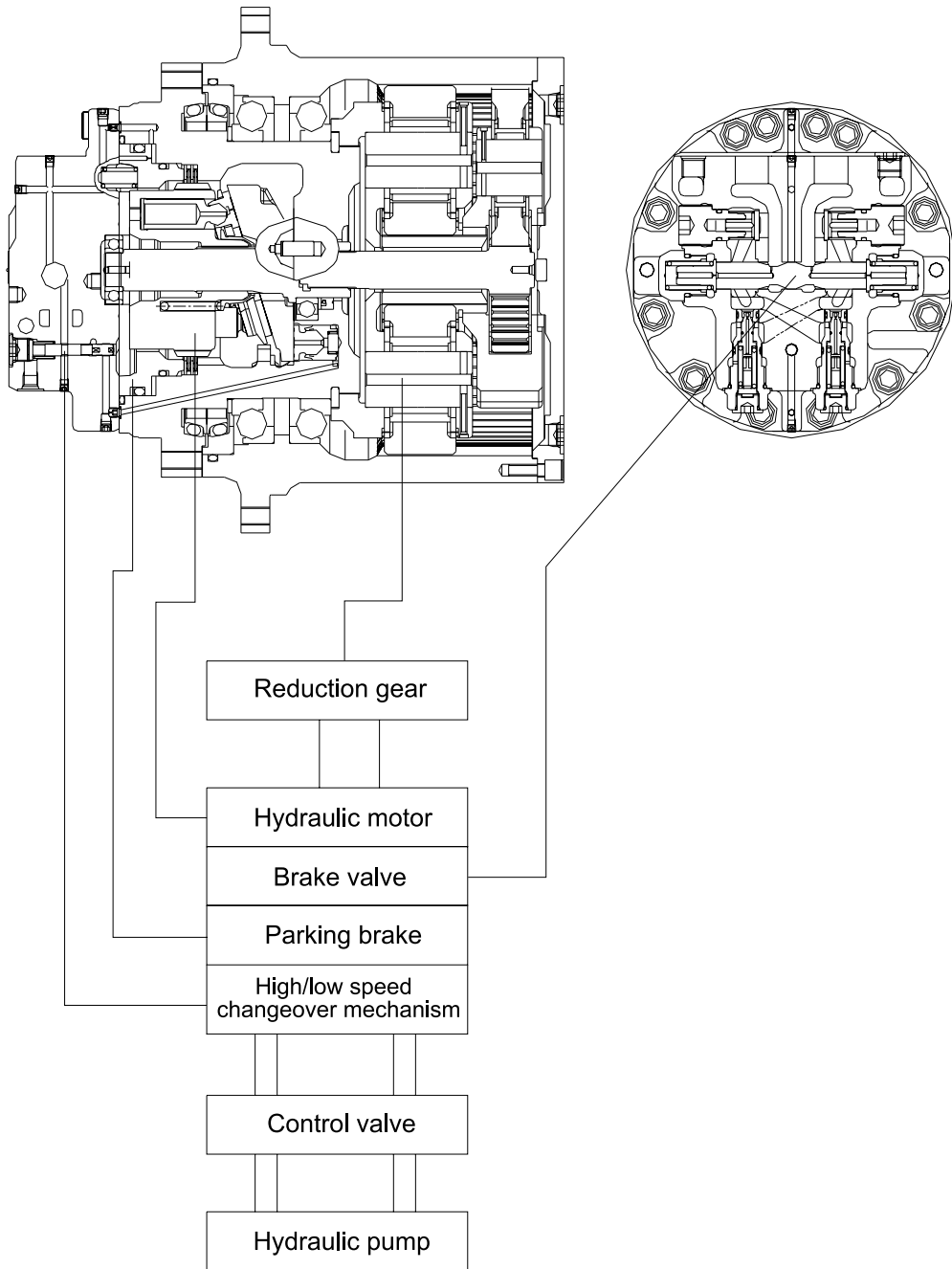

25092TM02

2) STRUCTURE

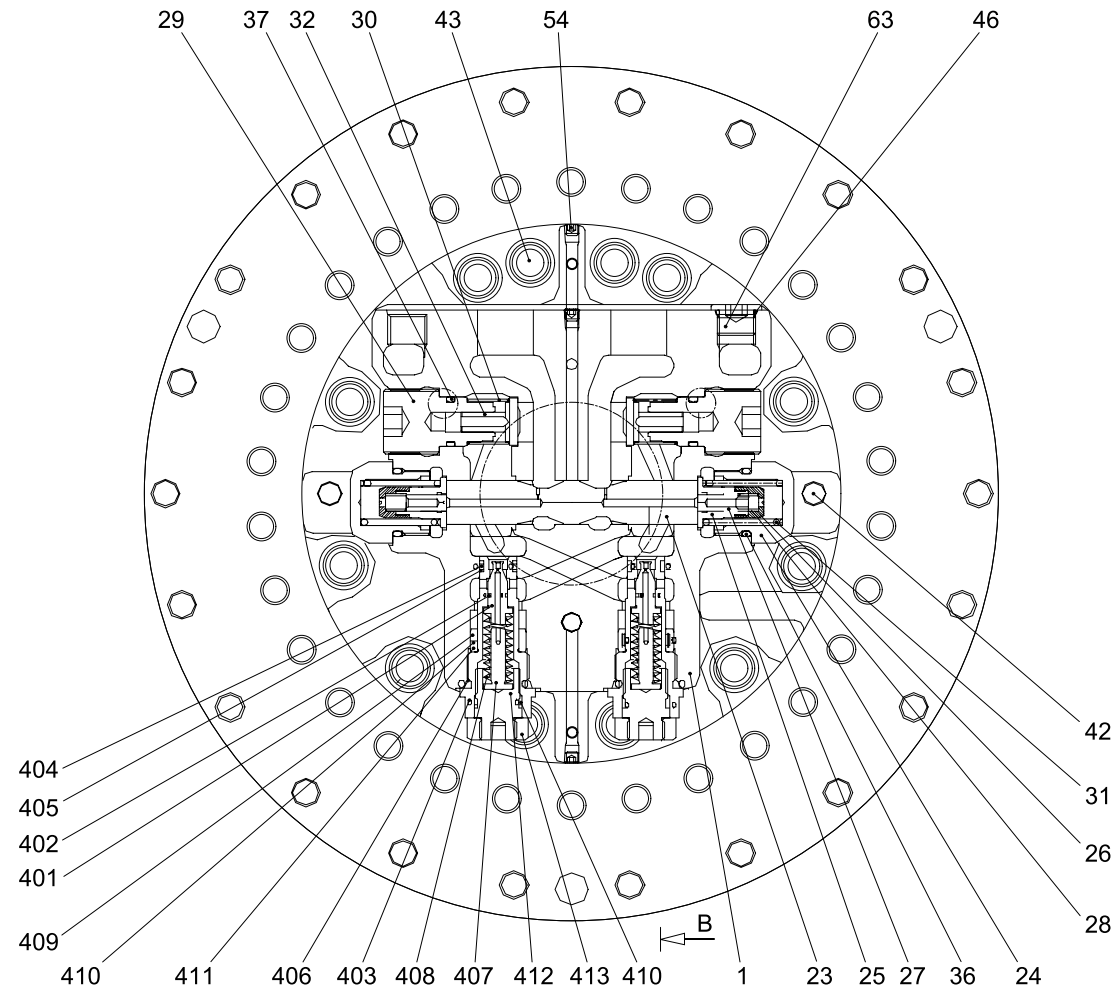

SECTION A - A

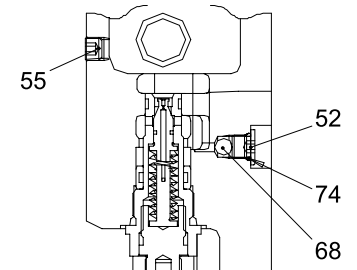
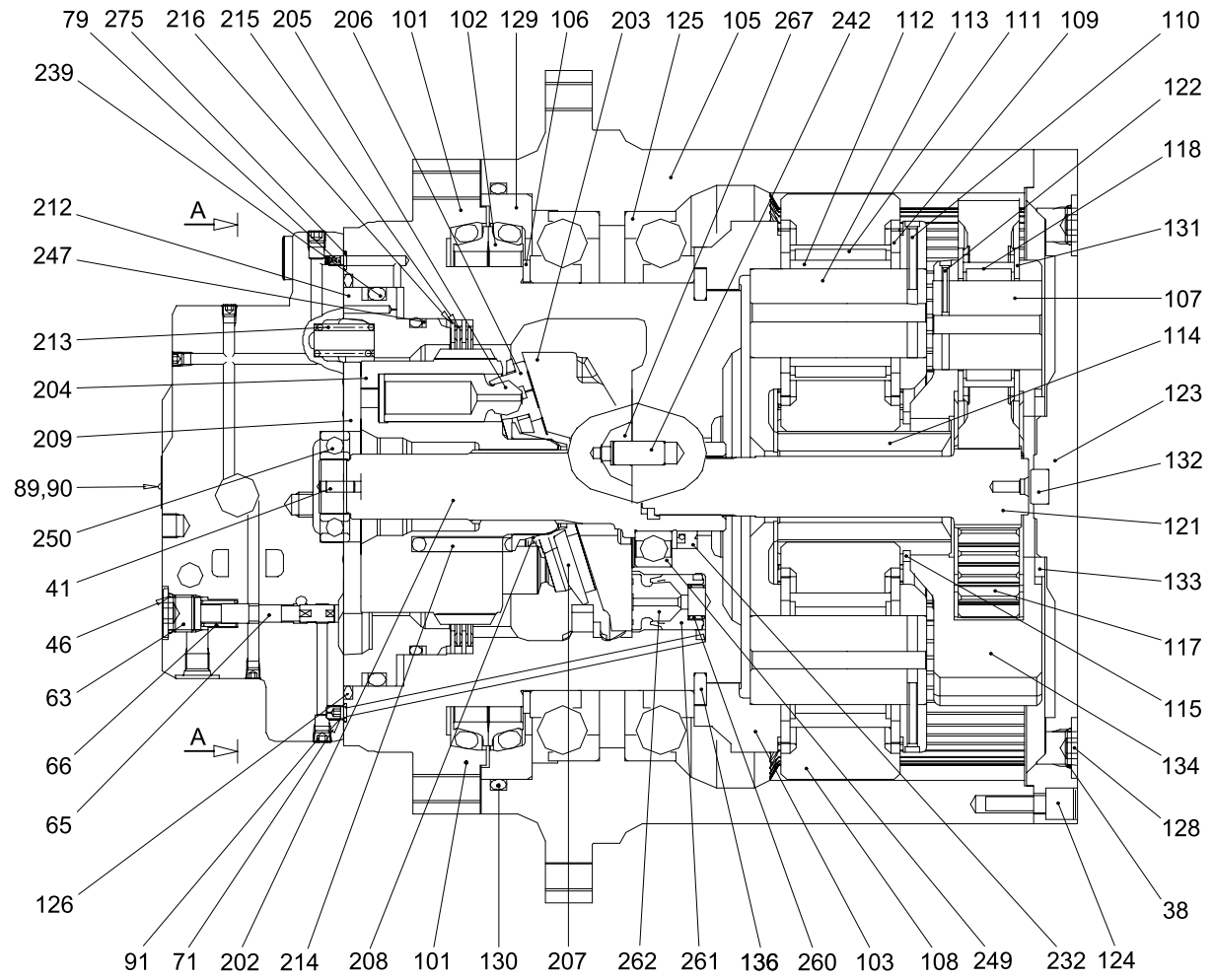

SECTION B - B

| | | | | | | | | | | | |
|----|--------------------|-----|------------------|-----|----------------------|-----|----------------------|-----|-------------------|-----|-----------------|
| 1 | Rear flange | 46 | O-ring | 106 | Distance piece | 126 | O-ring | 212 | Piston (parking) | 275 | O-ring |
| 23 | Main spool | 52 | Plug | 107 | Shaft bearing (R) | 128 | Plug | 213 | Spring (parking) | 401 | Plunger |
| 24 | Plug (for main) | 54 | Plug | 108 | Planetary gear (F) | 129 | Seal ring | 214 | Spring (cylinder) | 402 | Piston seal |
| 25 | Stopper-A | 55 | Plug | 109 | Thrust washer (F) | 130 | O-ring | 215 | Friction plate | 403 | Body |
| 26 | Stopper-B | 63 | Plug | 110 | Pin spring | 131 | Thrust washer (R) | 216 | Mating plate | 404 | Back up ring |
| 27 | Spool | 65 | Spool (2 speed) | 111 | Needle bearing | 132 | Thrust washer (M) | 232 | Oil seal | 405 | O-ring |
| 28 | Spring | 66 | Spring (2 speed) | 112 | Floating bushing | 133 | Thrust washer | 235 | O-ring | 406 | O-ring |
| 29 | Plug (for check) | 68 | Steel ball | 113 | Shaft bearing (F) | 134 | Carrier No.1 | 239 | O-ring | 407 | Spring retainer |
| 30 | Check valve | 71 | Orifice | 114 | Sun gear | 136 | Shim plate | 242 | Parallel pin | 408 | Spring |
| 31 | Spring (for main) | 74 | O-ring | 115 | Snap ring | 202 | Drive shaft | 247 | Back up ring | 409 | Piston |
| 32 | Spring (for check) | 79 | Filter | 117 | Planetary gear (R) | 203 | Swash plate (D type) | 248 | Back up ring | 410 | O-ring |
| 36 | O-ring | 91 | Plug | 118 | Needle bearing | 204 | Cylinder block | 249 | Ball bearing | 411 | Back up ring |
| 37 | O-ring | 101 | Spindle | 121 | Driver gear | 205 | Piston | 250 | Ball bearing | 412 | Adjust plug |
| 38 | O-ring | 102 | Floating seal | 122 | Pin spring | 206 | Shoe | 260 | Spring (2 speed) | 413 | Lock nut |
| 41 | Parallel pin | 103 | Carrier No.2 | 123 | Cover | 207 | Retainer plate | 261 | Piston (2 speed) | | |
| 43 | Socket bolt | 105 | Hub | 124 | Socket bolt | 208 | Thrust ball | 262 | Shoe (2 speed) | | |
| | | | | 125 | Angular ball bearing | 209 | Timing plate | 267 | Pivot | | |

25092TM03

2. HYDRAULIC MOTOR ASSEMBLY

With brake valve, parking brake and high/low speed changeover mechanism.

1) FUNCTION

(1) Hydraulic motor

This hydraulic motor is a swash plate type piston motor and converts the force of pressurized oil delivered from the pump into a rotational movement.

(2) Brake valve

This brake valve is incorporated in the hydraulic motor assembly and has the following four functions.

- ① Smoothly brakes and stops the motor by controlling inertial rotation of the motor due to inertia of the main body.
- ② Check valve function to prevent cavitation of the hydraulic motor.
- ③ Relief valve function to control the brake pressure of hydraulic motor and anti-cavitation valve function to prevent cavitation.
- ④ Opens a port which releases the parking brake force upon running of the motor and closes the upon stopping.

(3) Parking brake

The parking brake prevents overrunning or slippage upon parking or stopping the machine on a slope with friction plate type brake mechanism, and combined with the hydraulic motor assembly into an integral structure.

(4) High/low speed changeover mechanism

This mechanism changes over the tilt angle of swash plate between high-speed/low-torque rotation and low-speed/high-torque rotation with the changeover valve and control piston.

2) OPERATING PRINCIPLE

(1) Hydraulic motor

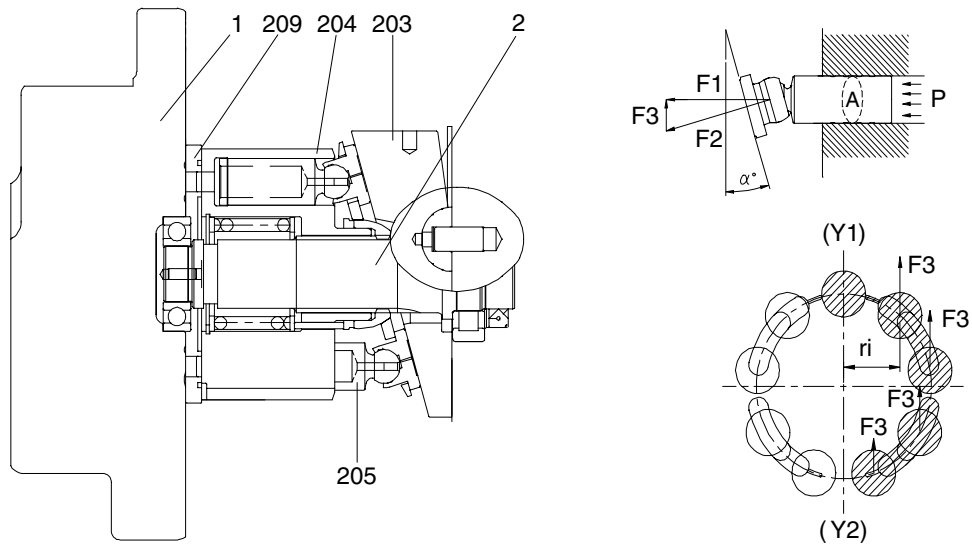

25092TM05

The pressurized oil delivered from the hydraulic pump flows to rear flange (1) of the motor, passes through the brake valve mechanism and is introduced into cylinder block (204) via timing plate (209). This oil constructively introduced only to one side of (Y1) - (Y2) connecting the upper and lower dead points of stroke of piston (205). The pressurized oil fed to one side in cylinder block (204) pushes each piston (205)(four or five) and generates a force ($F \text{ kgf} = P \text{ kgf/cm}^2 \times A \text{ cm}^2$). This force acts on swash plate (203) and is resolved into components (F2 and F3) because swash plate (203) is fixed at an angle (α°) with the axis of drive shaft (202). Radial component (F3) generates respective torques ($T = F3 \times r_i$) for (Y1) - (Y2). This residual of torque ($T = S (F3 \times r_i)$) rotates cylinder block (204) via piston (205). Cylinder block (4) is spline coupled with drive shaft (202). So the drive shaft (202) rotates and the torque is transmitted.

(2) Brake valve

① Brake released

When the pressurized oil supplied from port (A), the oil opens valve (30) and flows into port (C) at the suction side of hydraulic motor to rotate motor.

At the same time, the pressurized oil passes through pipe line (a) from a small hole in spool (23) and flow into chamber (b). The oil acts on the end face of spool (23) which is put in neutral position by the force of spring (31), thus causing spool (23) to slide to the left. When spool (23) slides, port (D) on the passage return side of hydraulic motor, which is closed by the spool groove during stoppage, communicates with port (B) at the tank side and the return oil from the hydraulic motor runs into the tank. In consequence, the hydraulic motor rotates.

Moreover, sliding of spool (23) causes the pressurized oil to flow into ports (P) and (S). The pressurized oil admitted into port (P) activates piston (212) of the parking brake to release the parking brake force. (For details, refer to description of the parking brake.) When the pressurized oil is supplied from port (B), spool (23) and valve (30) move reversely and the hydraulic motor also rotates reversely.

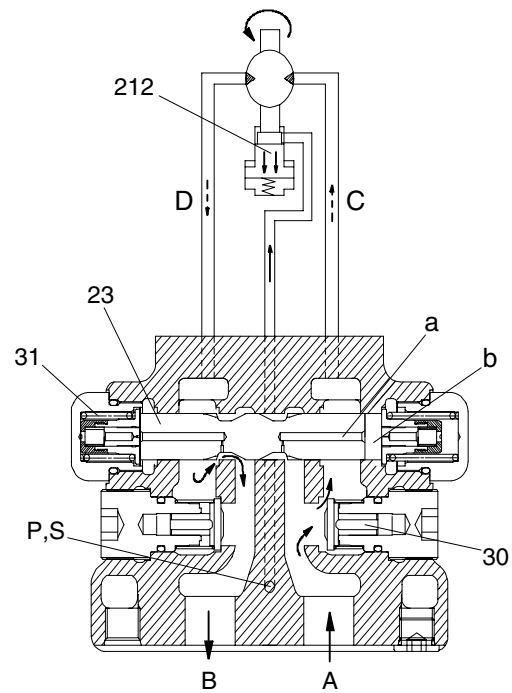

25092TM06

② Stopping and stalling (brake applied)

When the pressurized oil supplied from port (A) is stopped during traveling, no hydraulic pressure is applied and spool (23) which has slid to the left will return on the right (neutral) via stopper (25, 26) by the force of spring (31). At the same time, the hydraulic motor will rotate by the inertia even if the pressurized oil stopped, so the port (D) of the motor will become high pressure. This pressurized oil goes from chamber (f) to chamber (g) through the left-hand valve (401). When the oil enters chamber (g), the piston (409) slides to the right so as not to rise the pressure, as shown in the figure. Meanwhile, the left-hand valve (401) is pushed open by the pressurized oil in port (D). Therefore, the pressurized oil in port (D) flows to port (C) at a relatively low pressure, controlling the pressure in port (D) and preventing cavitation in port (C). When the piston (409) reaches the stroke end, the pressure in chamber (g) and (f) increase and the left-hand valve (401) closes again, allowing the oil pressure in port (D) to increase further. Then, the right-hand valve opens port (C) with pressure higher than that machine relief set pressure. In this way, by controlling the pressure in port (D) in two steps, the hydraulic motor is smoothly braked and to a stop.

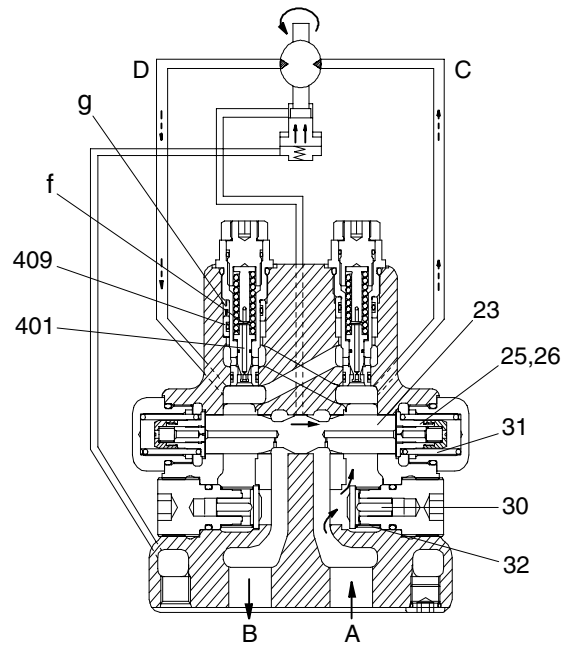

25092TM07

(3) Parking brake

① Running

When the pressurized oil is supplied from the valve, the spool of brake valve in the hydraulic motor assembly actuates to open the passage to the parking brake and the pressurized oil is introduced into cylinder chamber (a) which is composed of the spindle of reduction gear assembly and piston (212). When the hydraulic pressure reaches 9.5 kgf/cm^2 or more, it overcomes the force of spring (213) and shifts piston (212). With shift of piston (212), no pressing force is applied to mating plate (216) and friction plate (215) and movement of friction plate (215) becomes free. Whereby the brake force to the cylinder in the hydraulic motor assembly is released.

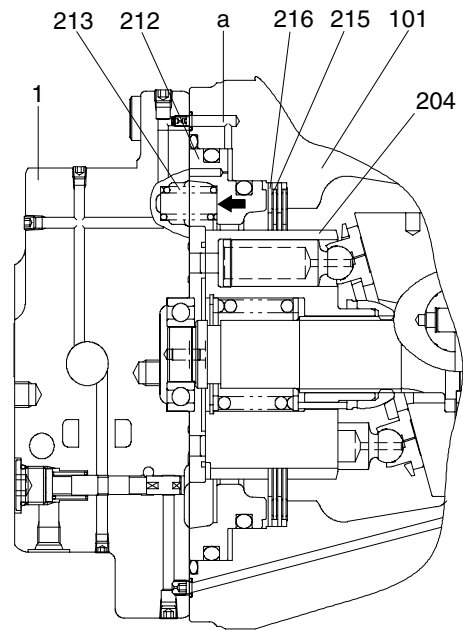

25092TM08

② Stopping

When the pressurized oil from the brake valve is shut off and the pressure in cylinder chamber (a) drops 9.5 kgf/cm^2 or less, piston (212) will return by the force of spring (213). Piston (212) is pushed by this force of spring (13), and mating plate (216) and friction plate (215) in free condition are pressed against the spindle of reduction gear assembly. The friction force produced by this pressing stops rotation of the cylinder and gives a braking torque $40.6 \text{ kgf} \cdot \text{m}$ to the hydraulic motor shaft. Note that oil control through a proper oil passage ensures smooth operation.

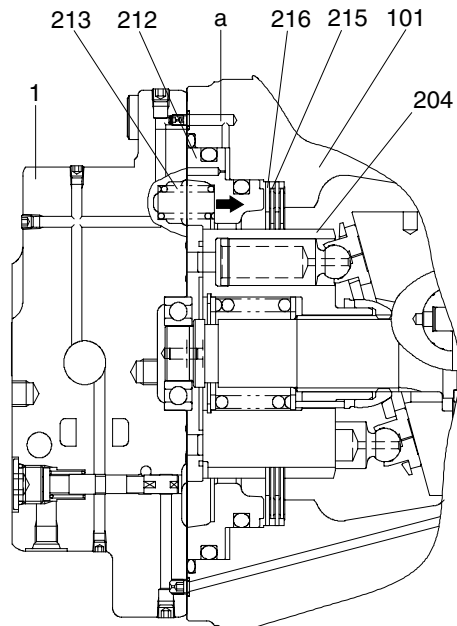

25092TM09

(4) High/low speed changeover mechanism

① At low speed - pilot pressure of less than 10 kgf/cm²

When no pilot pressure is supplied from (D) (at a pressure of 10 kgf/cm² or less), valve (65) is pressed toward the top by the force of spring (66) and (A) port or (B) port, the pressurized oil supply port (C) is shut off, and oil in chamber (P) is released into the motor case via valve(65). Consequently, swash plate (203) is tilted at a maximum angle (θ_1) and the piston displacement of hydraulic motor becomes maximum, thus leading to low-speed rotation.

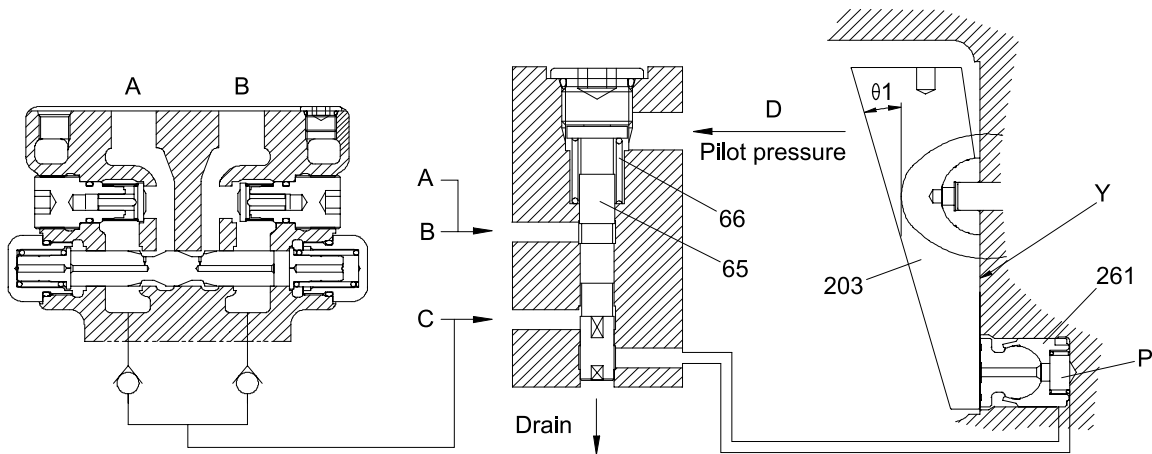

② At high speed - pilot pressure of 10 kgf/cm² or more

When a pilot pressure is supplied from port (D) (at a pressure of 20 kgf/cm² or more), the pressure overcomes the force of spring (66) and (A) port or (B) port of valve (65) is pressed toward the down. The pressurized oil at supply port (C) is then introduced into chamber (P) via valve (65). Piston (261) pushes up swash plate (203) until it touches side Y of the spindle. At this time, swash plate (203) is tilted at a minimum angle (θ_2) and the piston displacement of hydraulic motor becomes minimum, thus leading to high-speed rotation.

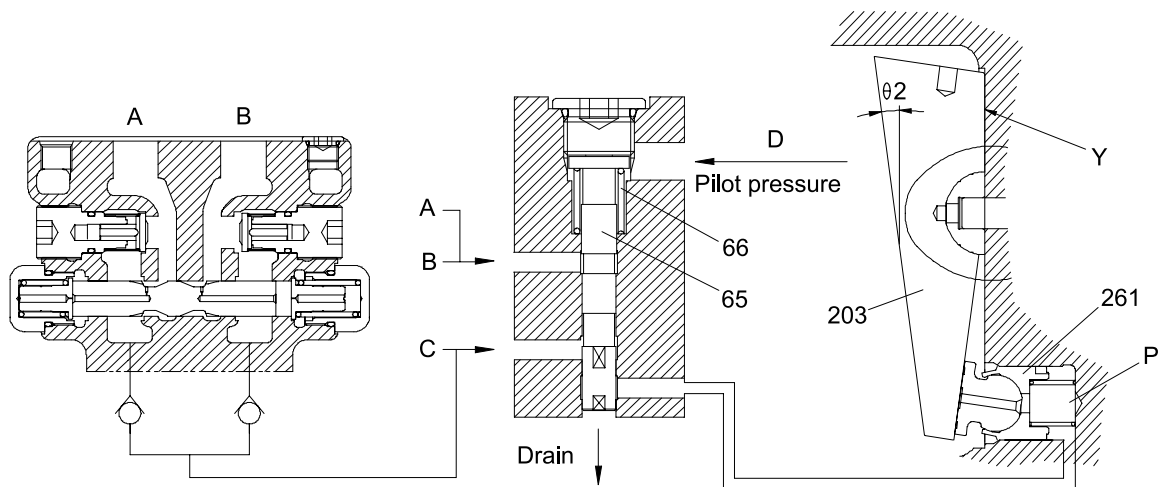

3. REDUCTION GEAR

1) The reduction gear is composed of a two-stage planetary gear mechanism shown in the following figure.

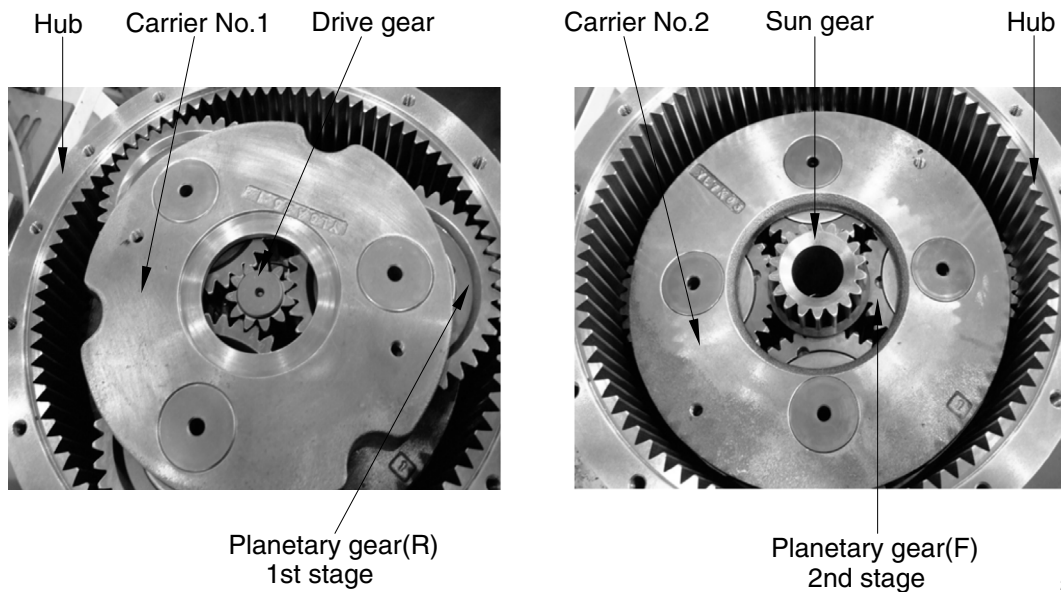

2) The rotating motion of the hydraulic motor is transmitted to drive gear of 1st stage, and the drive gear rotate planetary gears (R). Then planetary gears (R) revolves inside fixed hub. This rotation becomes the output of 1st stage and is transmitted to carrier No.1 and sun gear. Similary the revolution of planetary gears (F) are transmitted to spindle. Then planetary gears (F) do not revolve, but rotate to hub. Therefore, the rotating case is driven by the overall driving torque of hub.

This reduction ratio is expressed as shown below :

$$\text{Reduction ratio (I)} = (\text{Hub teeth} / \text{Drive gear teeth} + 1) \times (\text{Hub teeth} / \text{Sun gear teeth} + 1) - 1$$