

SECTION 2 STRUCTURE AND FUNCTION

Group 1 Pump Device	2-1
Group 2 Main Control Valve	2-20
Group 3 Swing Device	2-47
Group 4 Travel Device	2-58
Group 5 RCV Lever	2-66
Group 6 RCV Pedal	2-73

SECTION 2 STRUCTURE AND FUNCTION

GROUP 1 PUMP DEVICE

1. STRUCTURE

The pump device consists of main pump, regulator and gear pump.

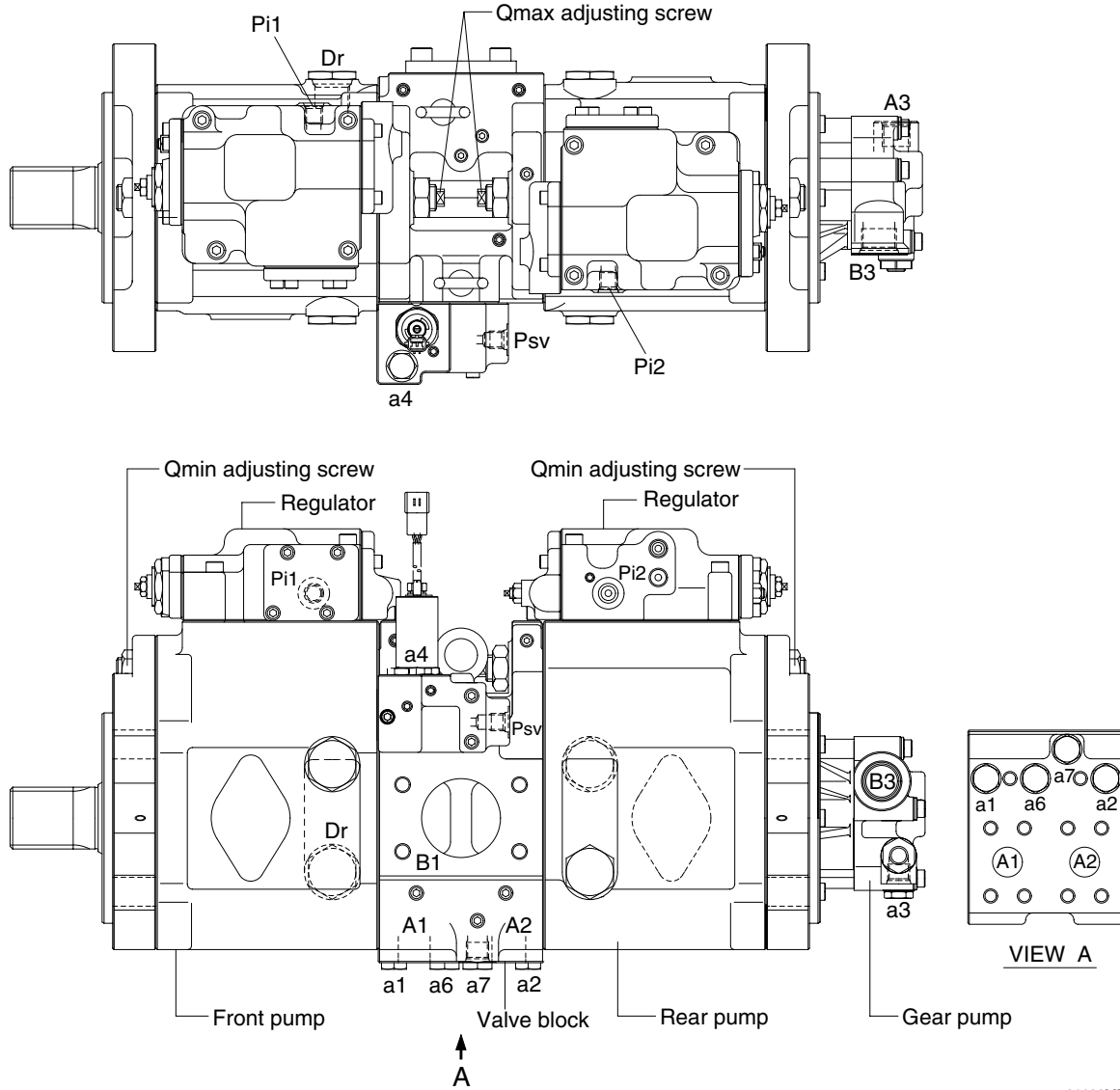

21092MP01

Port	Port name	Port size
A1,2	Delivery port	SAE6000psi 1"
B1	Suction port	SAE2500psi 2 1/2"
Dr	Drain port	PF 3/4 - 20
Pi1,i2	Pilot port	PF 1/4 - 15
Psv	Servo assist port	PF 1/4 - 15
a1,2,4	Gauge port	PF 1/4 - 15
a6, 7	Gauge port	PF 3/8-17
a3	Gauge port	PF 1/4-14
A3	Gear pump delivery port	PF 1/2 - 19
B3	Gear pump suction port	PF 3/4 - 20.5

1) MAIN PUMP (1/2)

The main pump consists of two piston pumps (front & rear) and valve block.

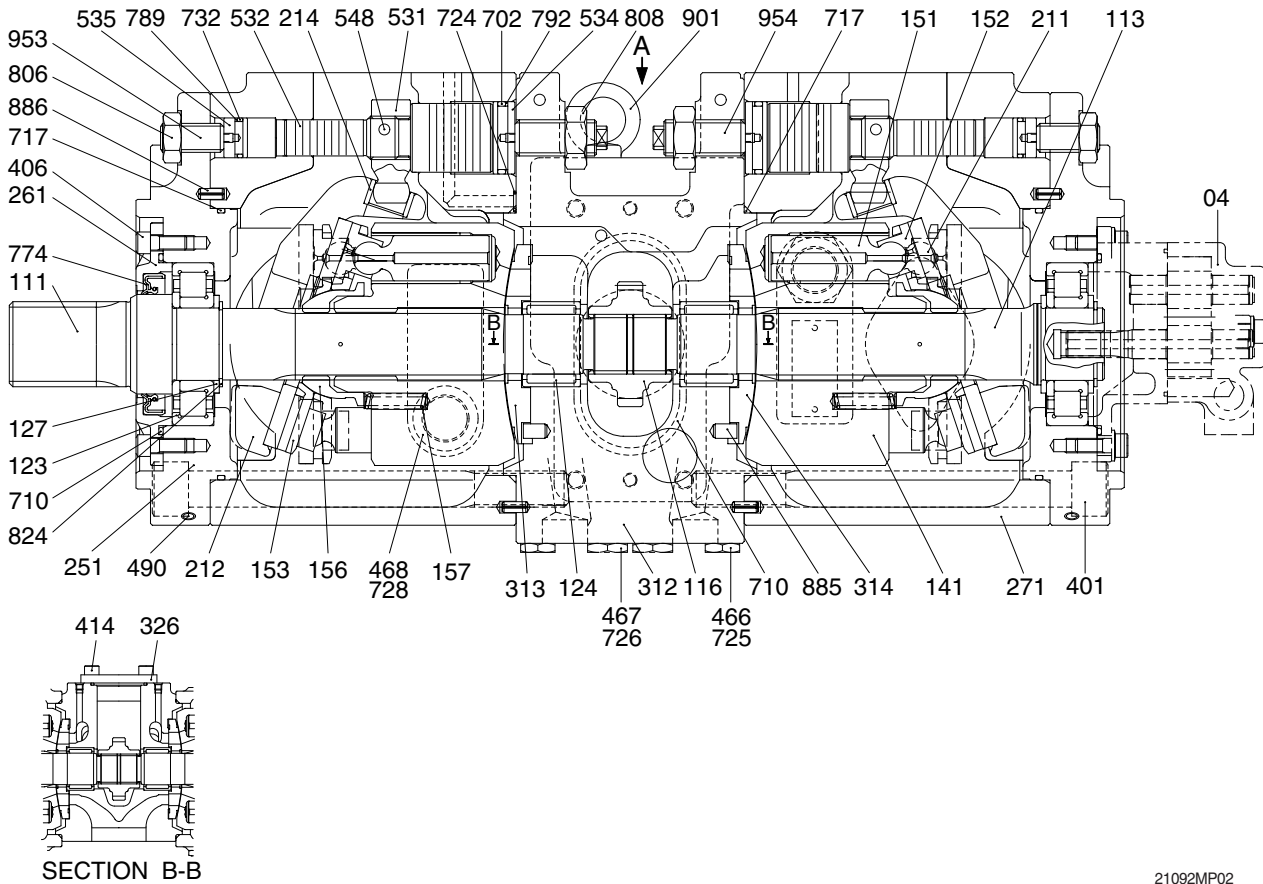

21092MP02

04	Gear pump	271	Pump casing	710	O-ring
111	Drive shaft (F)	312	Valve block	717	O-ring
113	Drive shaft (R)	313	Valve plate (R)	724	O-ring
116	Gear	314	Valve plate (L)	725	O-ring
123	Roller bearing	326	Cover	726	O-ring
124	Needle bearing	401	Hexagon socket bolt	728	O-ring
127	Bearing spacer	406	Hexagon socket bolt	732	O-ring
141	Cylinder block	414	Hexagon socket bolt	774	Oil seal
151	Piston	466	VP Plug	789	Back up ring
152	Shoe	467	VP plug	792	Back up ring
153	Set plate	468	VP Plug	806	Hexagon head nut
156	Bushing	490	Plug	808	Hexagon head nut
157	Cylinder spring	531	Tilting pin	824	Snap ring
211	Shoe plate	532	Servo piston	885	Pin
212	Swash plate	534	Stopper (L)	886	Spring pin
214	Bushing	535	Stopper (S)	901	Eye bolt
251	Support	548	Pin	953	Set screw
261	Seal cover (F)	702	O-ring	954	Set screw

MAIN PUMP (2/2)

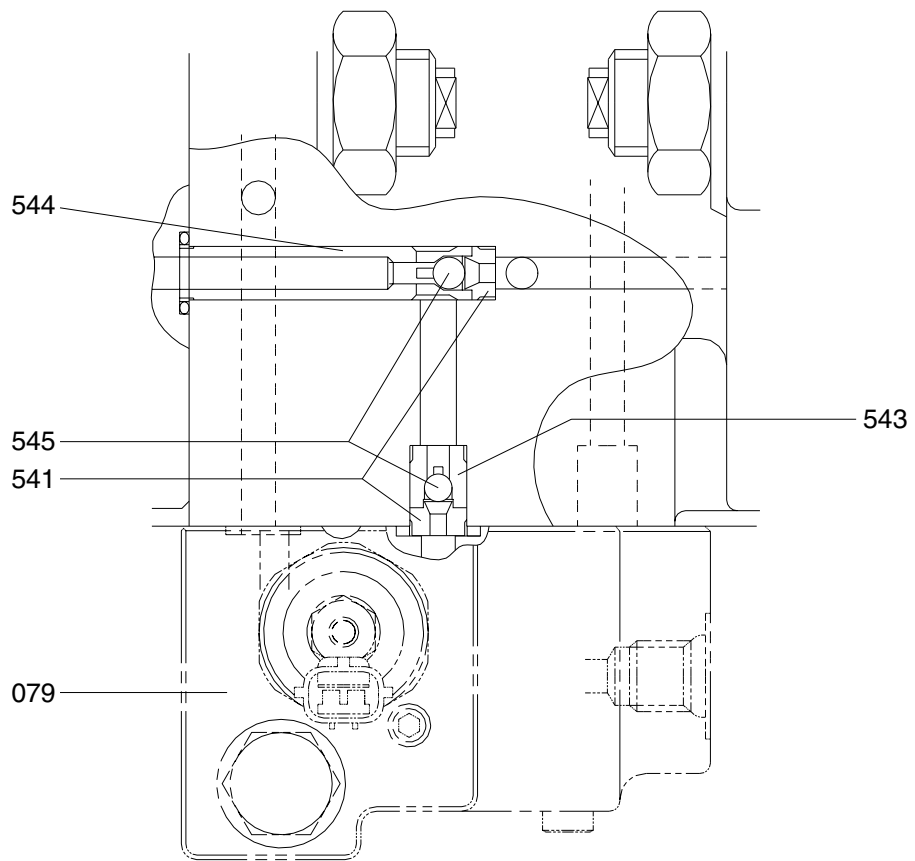

VIEW A

21092MP08

- | | | | | | |
|-----|-----------------------------|-----|-----------|-----|------------|
| 079 | Proportional reducing valve | 543 | Stopper 1 | 545 | Steel ball |
| 541 | Seat | 544 | Stopper 2 | | |

2) REGULATOR (1/2)

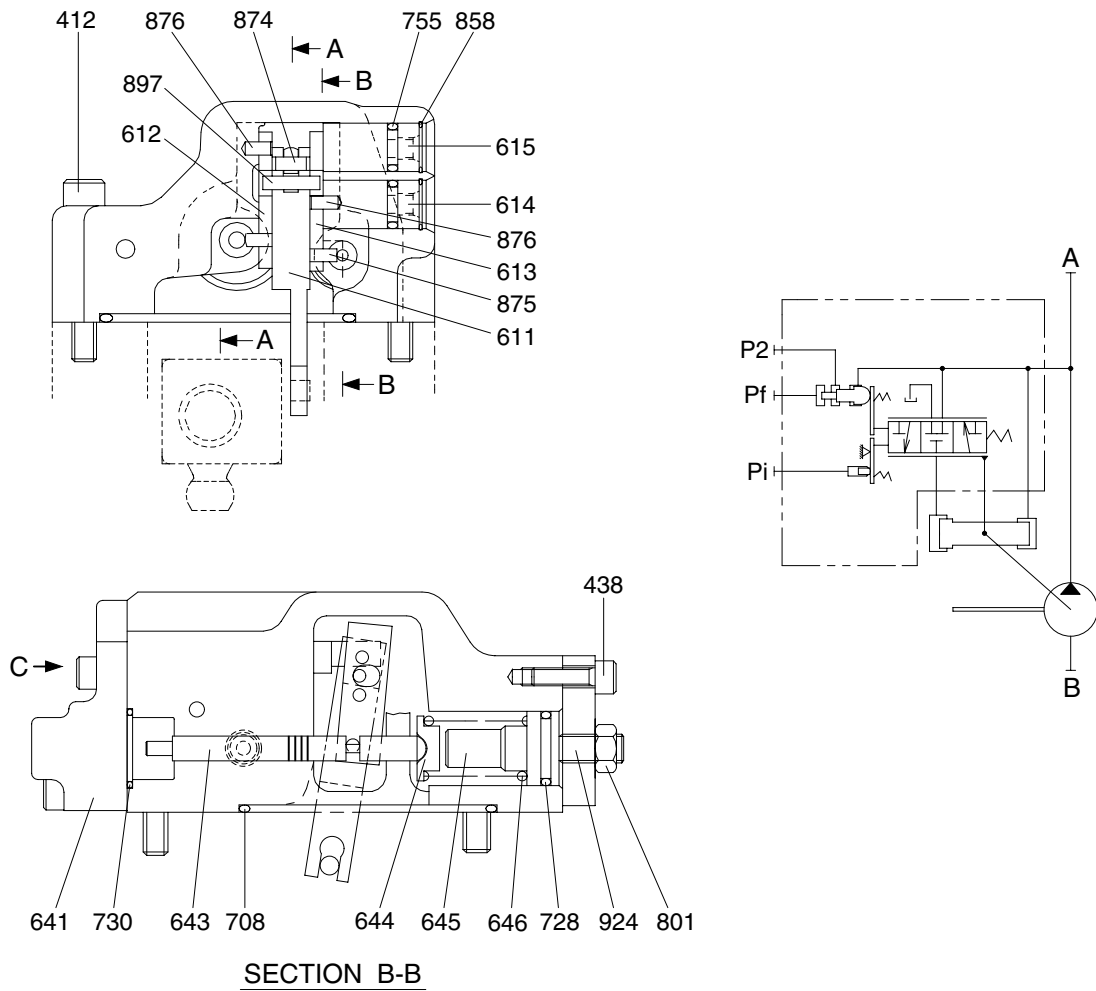

SECTION B-B

21092MP03

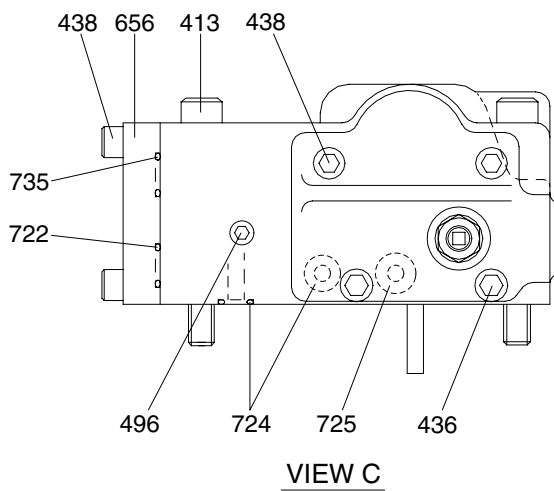

VIEW C

Port	Port name	Port size
A	Delivery port	1"
B	Suction port	2 1/2"
Pi	Pilot port	PF 1/4-15
Pf	Power shift port	-
P2	Companion delivery port	-

REGULATOR (2/2)

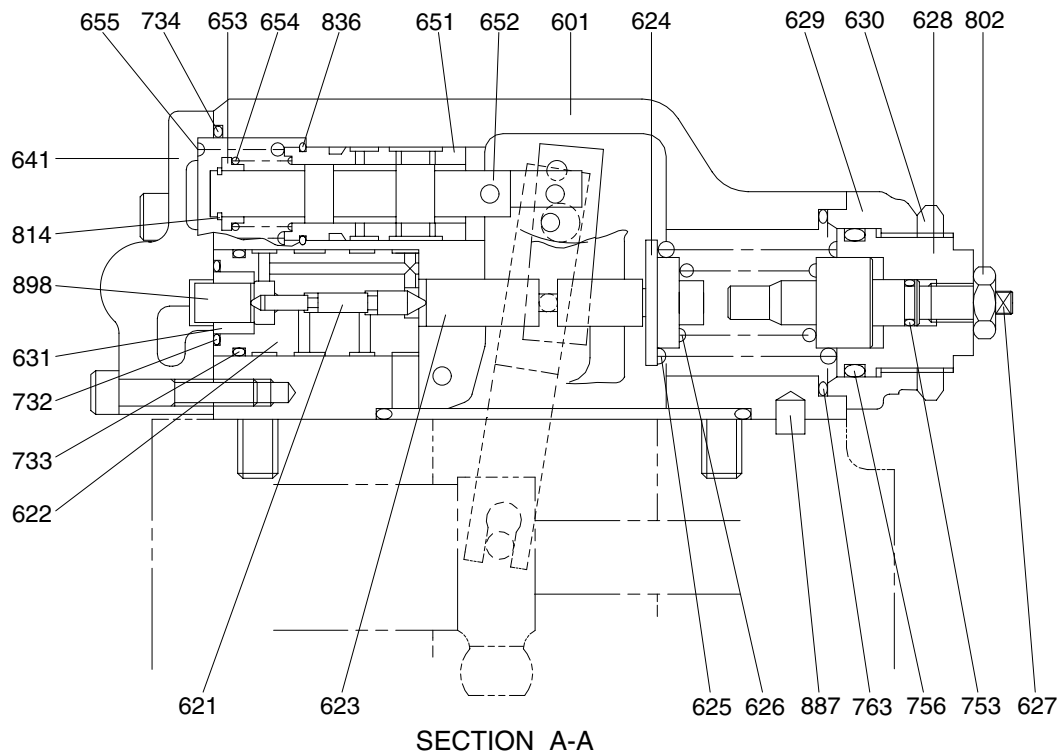

21092MP04

412 Hexagon socket screw	630 Lock nut	733 O-ring
413 Hexagon socket screw	631 Sleeve, pf	734 O-ring
436 Hexagon socket screw	641 Pilot cover	735 O-ring
438 Hexagon socket screw	643 Pilot piston	753 O-ring
496 Plug	644 Spring seat (Q)	755 O-ring
601 Casing	645 Adjust stem (Q)	756 O-ring
611 Feed back lever	646 Pilot spring	763 O-ring
612 Lever (1)	651 Sleeve	801 Nut
613 Lever (2)	652 Spool	802 Nut
614 Fulcrum plug	653 Spring seat	814 Snap ring
615 Adjust plug	654 Return spring	836 Snap ring
621 Compensator piston	655 Set spring	858 Snap ring
622 Piston case	656 Block cover	874 Pin
623 Compensator rod	708 O-ring	875 Pin
624 Spring seat (C)	722 O-ring	876 Pin
625 Outer spring	724 O-ring	887 Pin
626 Inner spring	725 O-ring	897 Pin
627 Adjust stem (C)	728 O-ring	898 Pin
628 Adjust screw (C)	730 O-ring	924 Set screw
629 Cover (C)	732 O-ring	

3) GEAR PUMP

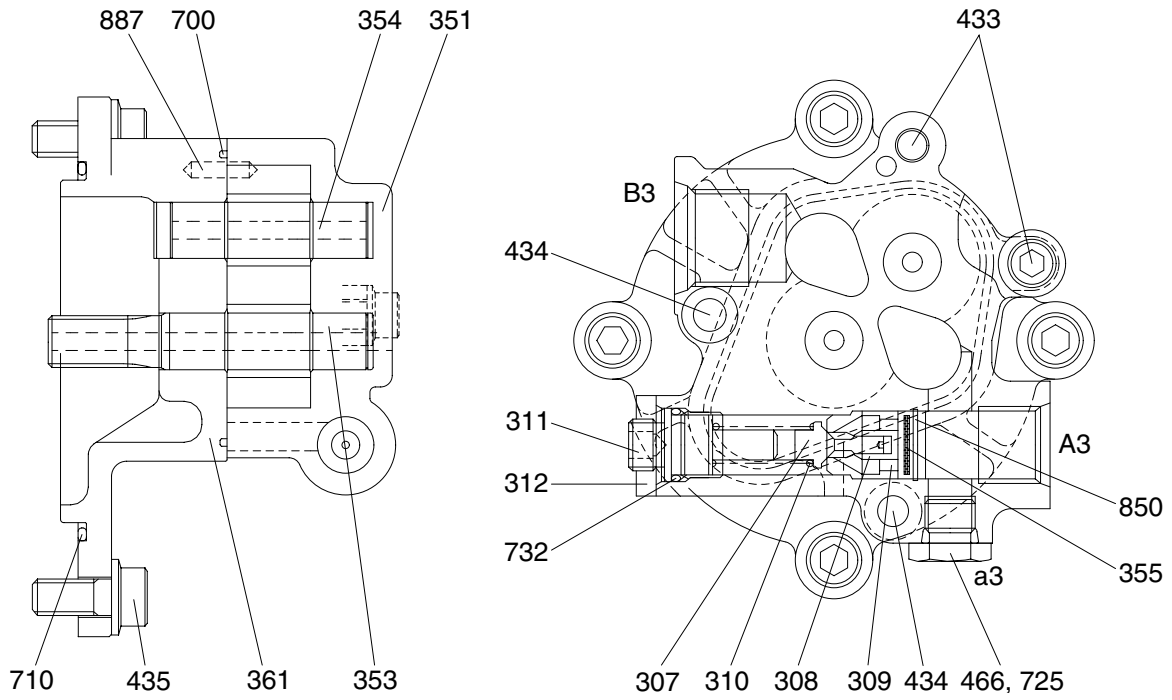

21092MP05

- | | | |
|-----------------|-------------------|---------------|
| 307 Poppet | 353 Drive gear | 466 Plug |
| 308 Seat | 354 Driven gear | 700 Ring |
| 309 Spring seat | 355 Filter | 710 O-ring |
| 310 Spring | 361 Front case | 725 O-ring |
| 311 Screw | 433 Flange socket | 732 O-ring |
| 312 Nut | 434 Flange socket | 850 Snap ring |
| 351 Gear case | 435 Flange socket | 887 Pin |

2. FUNCTION

1) MAIN PUMP

The pumps may be classified roughly into the rotary group performing a rotary motion and working as the major part of the whole pump function: the swash plate group that varies the delivery rates: and the valve cover group that changes over oil suction and discharge.

(1) Rotary group

The rotary group consists of drive shaft (F) (111), cylinder block (141), piston shoes (151,152), set plate (153), spherical bushing (156) and cylinder spring (157). The drive shaft is supported by bearing (123,124) at its both ends.

The shoe is caulked to the piston to form a spherical coupling. It has a pocket to relieve thrust force generated by loading pressure and to take hydraulic balance so that it slides lightly over the shoe plate (211). The sub group composed by a piston and a shoe is pressed against the shoe plate by the action of the cylinder spring via a retainer and a spherical bush. Similarly, the cylinder block is pressed against valve plate (313) by the action of the cylinder spring.

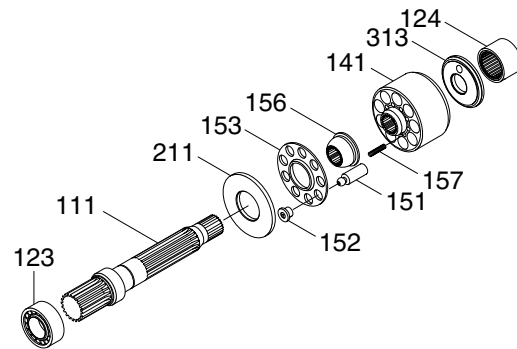

21092MP06

(2) Swash plate group

The swash plate group consists of swash plate (212), shoe plate (211), swash plate support (251), tilting bush (214), tilting pin (531) and servo piston (532).

The swash plate is a cylindrical part formed on the opposite side of the sliding surface of the shoe and is supported by the swash support.

If the servo piston moves to the right and left as hydraulic force controlled by the regulator is admitted to hydraulic chamber located on both sides of the servo piston, the swash plate slides over the swash plate support via the spherical part of the tilting pin to change the tilting angle (α).

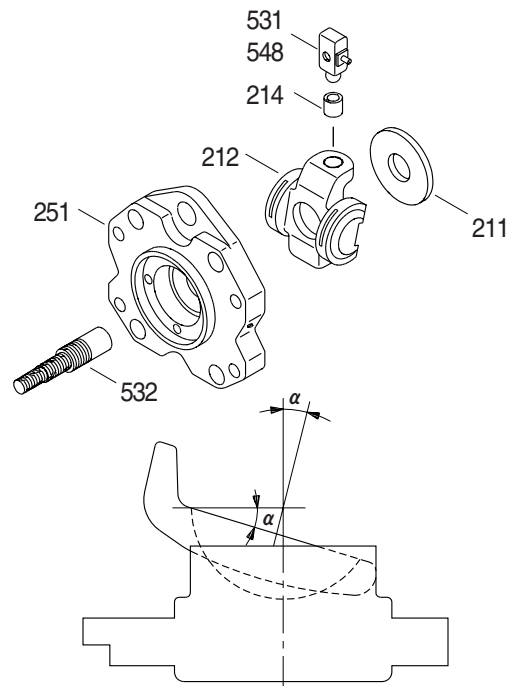

2-7

(3) Valve block group

The valve block group consists of valve block (312), valve plate (313) and valve plate pin(885).

The valve plate having two melon-shaped ports is fixed to the valve block and feeds and collects oil to and from the cylinder block.

The oil changed over by the valve plate is connected to an external pipeline by way of the valve block.

Now, if the drive shaft is driven by a prime mover (electric motor, engine, etc), it rotates the cylinder block via a spline linkage at the same time. If the swash plate is tilted as in Fig (previous page) the pistons arranged in the cylinder block make a reciprocating motion with respect to the cylinder block, while they revolve with the cylinder block.

If you pay attention to a single piston, it performs a motion away from the valve plate (oil sucking process) within 180 degrees, and makes a motion towards the valve plate (or oil discharging process) in the rest of 180 degrees. When the swash plate has a tilting angle of zero, the piston makes no stroke and discharges no oil.

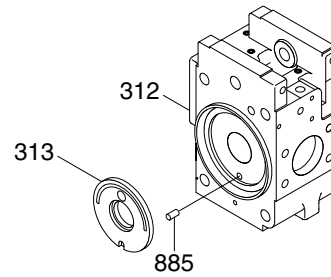

21092MP07

2) REGULATOR

Regulator consists of the positive flow control, constant horse power control and variable horse power control function.

(1) Positive flow control

By changing the pilot pressure P_i , the pump tilting angle (delivery flow) is regulated arbitrarily, as shown in the figure.

This regulator is of the positive flow control in which the delivery flow Q increases as the pilot pressure P_i rises.

With this mechanism, when the pilot pressure corresponding to the flow required for the work is commanded, the pump discharges the required flow only, and so it does not consume the power uselessly.

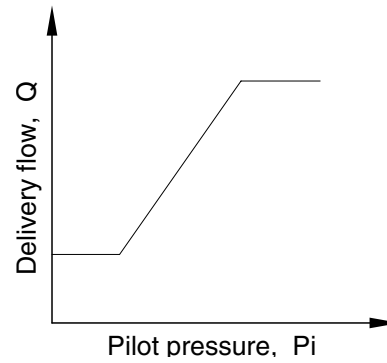

21092MP10

① Flow reducing function

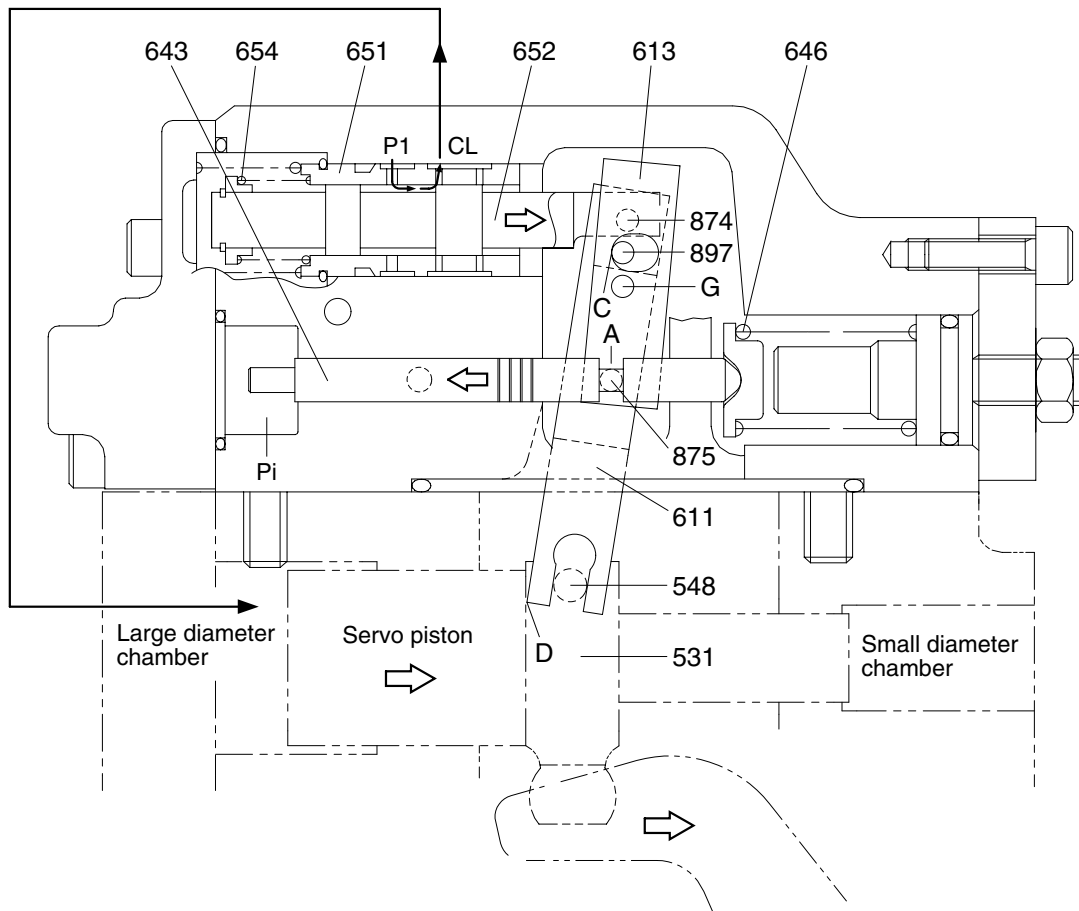

21092MP12

As the pilot pressure P_i decreases, the pilot piston (643) moves to the left by the action of the pilot spring (646) and causes lever 2 (613) to rotate around the fulcrum of point G. Since the pin (897) is pressed against the large hole section (C) of lever 2 by the action of the return spring (654) via the spool (652), pin (874), and feedback lever (611), the feedback lever rotates around the fulcrum of point D as lever 2 rotates, and shifts the spool to the right.

The movement of the spool causes the delivery pressure P_1 to connect to port CL through the spool and to be admitted to the large diameter section of the servo piston. The delivery pressure P_1 that is constantly admitted to the small diameter section of the servo piston moves the servo piston to the right due to the area difference, resulting in decrease of the tilting angle.

When the servo piston moves to the right, point D also moves to the right. The spool is fitted with the return spring (654) and is tensioned to the left at all times, and so the pin (897) is pressed against the large hole section (C) of lever 2.

Therefore, as point D moves, the feedback lever rotates around the fulcrum of point C, and the spool is shifted to the left. This causes the opening between the sleeve (651) and spool (652) to close slowly, and the servo piston comes to a complete stop when it closes completely.

② Flow increasing function

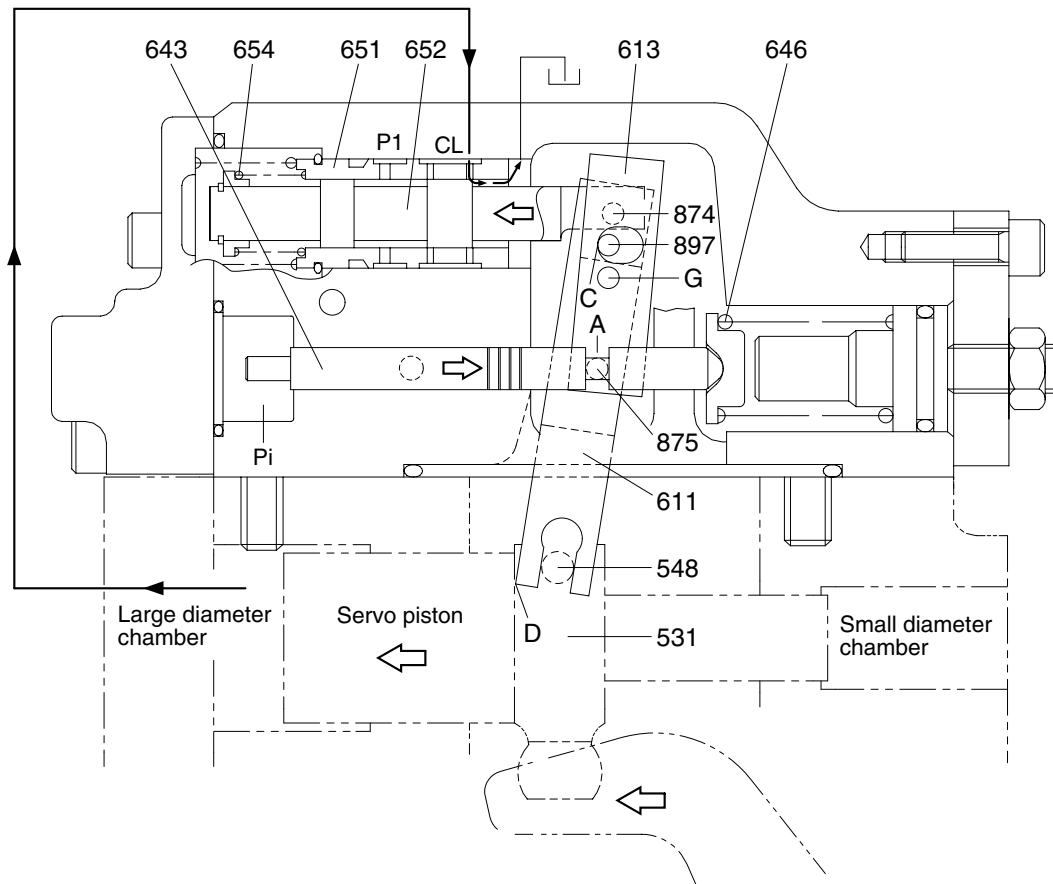

21092MP13

As the pilot pressure P_i rises, the pilot piston (643) moves to the right to a position where the force of the pilot spring (646) balances with the hydraulic force.

The groove (A) in the pilot piston is fitted with the pin (875) that is fixed to lever 2 (613). Therefore, when the pilot piston moves, lever 2 rotates around the fulcrum of point G [fixed by the fulcrum plug (614) and pin (875)]. Since the large hole section (C) of lever 2 contains a protruding pin (897) fixed to the feedback lever (611), the pin (897) moves to the left as lever 2 rotates.

Port CL opens a way to the tank port as the spool moves. This deprives the large diameter section of the servo piston of pressure, and shifts the servo piston to the left by the discharge pressure P_1 in the small diameter section, resulting in an increase in the flow rate.

As the servo piston moves, point D also moves to the left, the feedback lever rotates around the fulcrum of point C, and the spool moves to the right till the opening between the spool and sleeve is closed.

③ Adjustment of flow control characteristic

The flow control characteristic can be adjusted with the adjusting screw.

Adjust it by loosening the hexagon nut (801) and by tightening (or loosening) the hexagonal socket head screw (924).

Tightening the screw shifts the control chart to the right as shown in the figure.

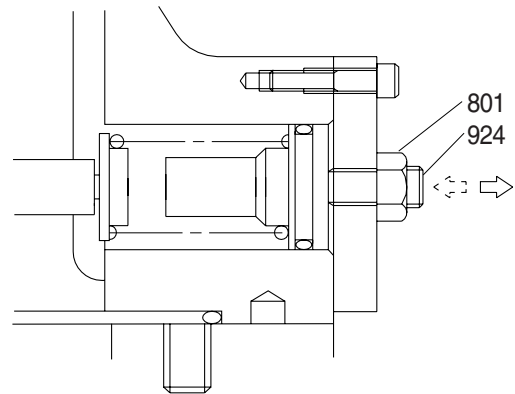

※ Adjusting value

Speed (min ⁻¹)	Adjustment of flow control characteristic		
	Tightening amount of adjusting screw(924) (Turn)	Flow control starting pressure change amount (kgf/cm ²)	Flow change amount (l /min)
1900	+1/4	+1.0	-17.6

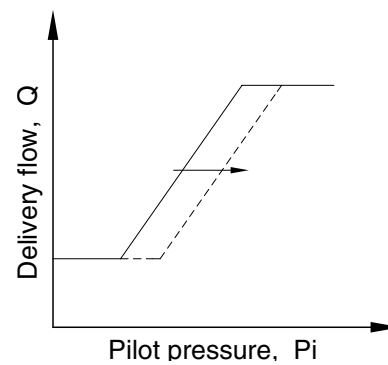

21092MP11

(2) Constant horsepower control

The regulator decreases the pump tilting angle (delivery flow) automatically to limit the input torque within a certain value with a rise in the delivery pressure P_1 of the self pump.

(The input horsepower is constant when the speed is constant.)

Since the regulator is of the simultaneous constant horsepower type that operates by the sum of load pressures of the two pumps in the tandem double-pump system, the prime mover is automatically prevented from being overloaded, irrespective of the load condition of the two pumps, when horsepower control is under way.

Since this regulator is of the simultaneous constant horsepower type, it controls the tilting angles (displacement volumes) of the two pumps to the same value as represented by the following equation :

$$\begin{aligned} T_{in} &= P_1 \times q/2\pi + P_2 \times q/2\pi \\ &= (P_1+P_2) \times q/2\pi \end{aligned}$$

The horsepower control function is the same as the flow control function and is summarized in the following. (for detailed behaviors of respective parts, refer to the section of flow control).

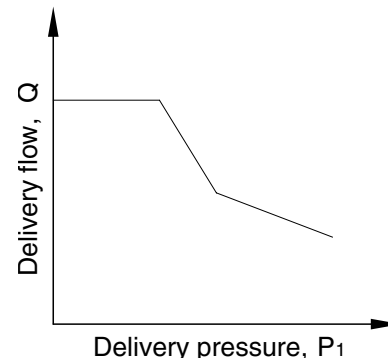

21092MP19

① Overload preventive function

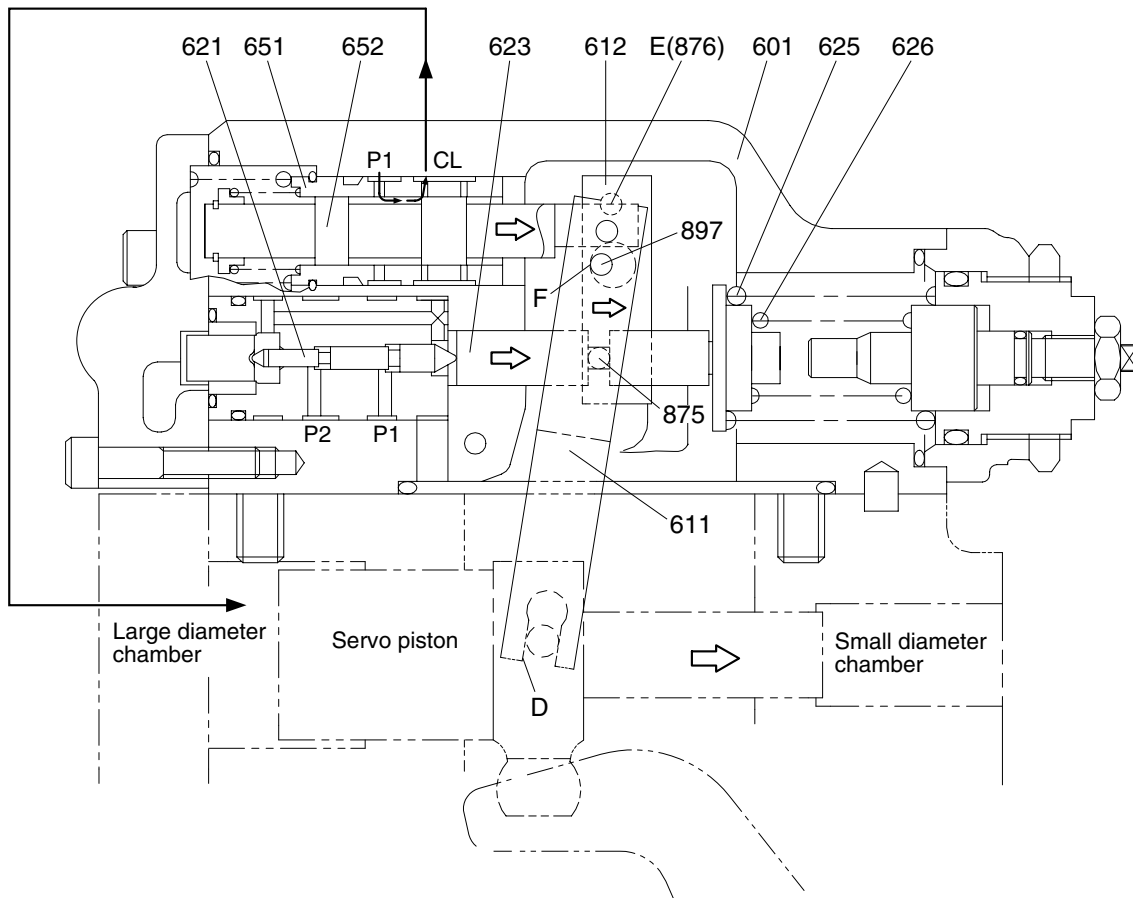

21092MP15

When the self pump delivery pressure P1 rises, it acts on the stepped part of the compensating piston (621). It presses the compensating rod (623) to the right till the force of the outer spring (625) and inner spring (626) balances with the hydraulic force. The movement of the compensating rod is transmitted to lever 1 (612) via pin (875).

Lever 1 rotates around the pin (876) (E) fixed to the casing (601).

Since the large hole section (F) of lever 1 contains a protruding pin (897) fixed to the feedback lever (611), the feedback lever rotates around the fulcrum of point D as lever 1 rotates, and then the spool (652) is shifted to the right. As the spool moves, the delivery pressure P1 is admitted to the large diameter section of the servo piston via port CL, causes the servo piston move to the right, reduces the pump delivery, flow rate, and prevents the prime mover from being overloaded. The movement of the servo piston is transmitted to the feedback lever via point D. Then the feedback lever rotates around the fulcrum of point F and the spool is shifted to the left. The spool moves till the opening between the spool (652) and sleeve (651) is closed.

② Flow reset function

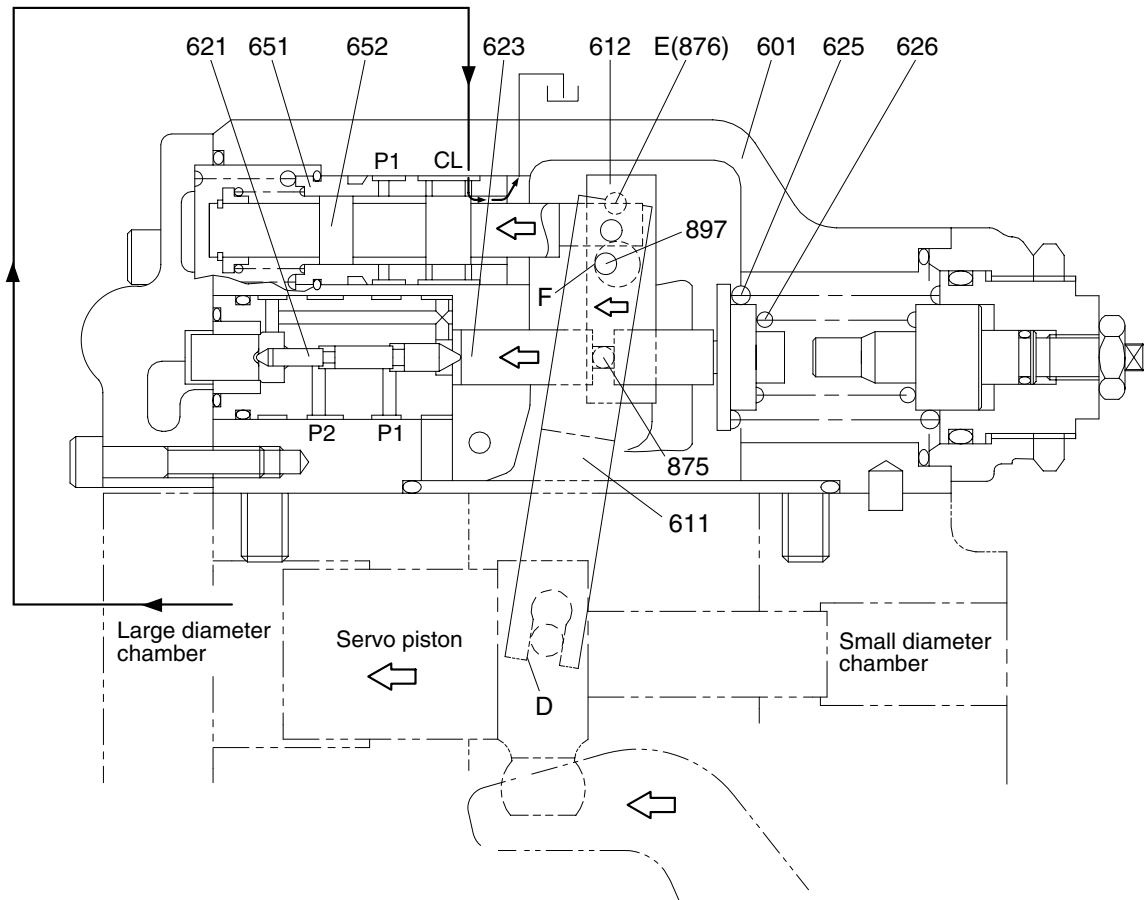

21092MP16

As the self pump delivery pressure P1, the compensating rod (623) is pushed back by the action of the springs (625 & 626) to rotate lever 1 (612) around point E. Rotating of lever 1 causes the feedback lever (611) to rotate around the fulcrum of point D and then the spool (652) to move to the left. As a result, port CL opens a way to the tank port.

This causes the servo piston to move to the left and the pump's delivery rate to increase.

The movement of the servo piston is transmitted to the spool by the action of the feedback mechanism to move it till the opening between the spool and sleeve is closed.

③ **Low tilting angle (low flow) command preferential function**

As mentioned above, flow control and horsepower control tilting angle commands are transmitted to the feedback lever and spool via the large-hole sections (C & F) of levers 1 and 2. However, since sections C and F have the pins ($\varnothing 4$) protruding from the large hole ($\varnothing 8$), only the lever lessening the tilting angle contacts the pin (897); the hole ($\varnothing 8$) in the lever of a larger tilting angle command is freed without contacting the pin (897). Such a mechanical selection method permits preference of the lower tilting angle command of the flow control and horsepower control.

④ **Adjustment of input horsepower**

a. **Adjustment of outer spring**

Adjust it by loosening the hexagon nut (630) and by tightening (or loosening) the adjusting screw C (628).

Tightening the screw shifts the control chart to the right and increases the input horsepower as shown in the figure. Since turning the adjusting screw C by N turns changes the setting of the inner spring (626), return the adjusting stem C (627) by $N \times A$ turns at first. ($A=1.78$)

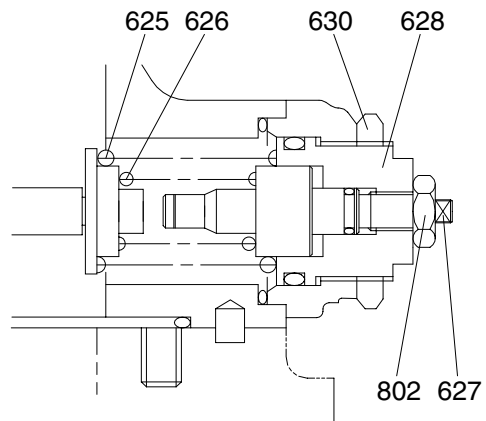

2107A2MP07

※ **Adjusting value**

Speed	Adjustment of input horsepower		
	Tightening amount of adjusting screw(627)	Compensating control starting pressure change amount	Input torque change amount
(min ⁻¹)	(Turn)	(kgf/cm ²)	(l /min)
1900	+1/4	+15.9	+4.0

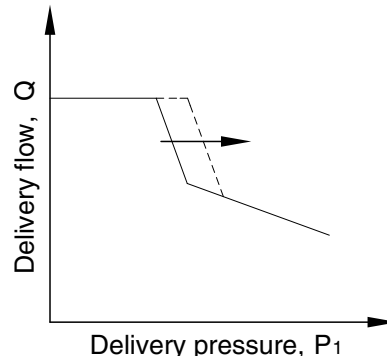

21092MP17

b. Adjustment of inner spring

Adjust it by loosening the hexagon nut (802) and by tightening (or loosening) the adjusting stem C (627).

Tightening the screw increases the flow and then the input horsepower as shown in the figure.

※ Adjusting value

Speed	Adjustment of input horsepower		
	Tightening amount of adjusting stem (C) (627)	Flow change amount	Input torque change amount
(min ⁻¹)	(Turn)	(l /min)	(kgf·m)
1900	+1/4	+11.3	+4.7

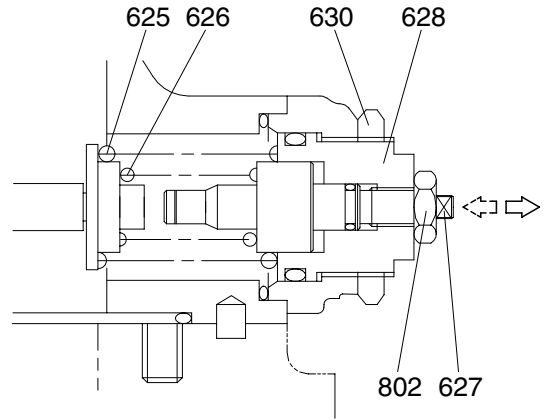

2107A2MP08

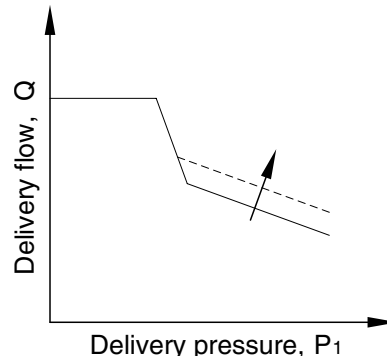

21092MP18

(4) Adjustment of maximum and minimum flows

The regulator can adjust the maximum and minimum flows with the adjusting screws.

① Adjustment of maximum flow

Adjust it by loosening the hexagon nut (808) and by tightening (or loosening) the set screw (954).

The maximum flow only is adjusted without changing other control characteristics.

Speed (min ⁻¹)	Adjustment of max flow	
	Tightening amount of adjusting screw (954) (Turn)	Flow change amount (l /min)
1900	+1/4	-5.5

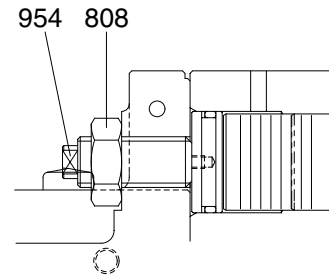

21092MP23

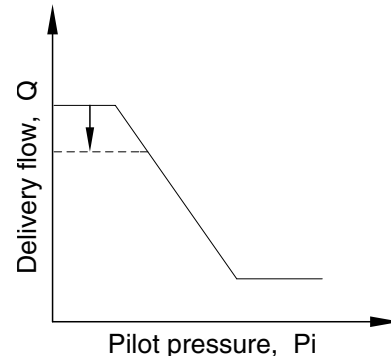

21092MP21

② Adjustment of minimum flow

Adjust it by loosening the hexagon nut (806) and by tightening (or loosening) the hexagonal socket head set screw (953). Similarly to the adjustment of the maximum flow, other characteristics are not changed.

However, remember that, if tightened too much, the required horsepower during the maximum delivery pressure (or during relieving) may increase.

Speed (min ⁻¹)	Adjustment of min flow	
	Tightening amount of adjusting screw (953) (Turn)	Flow change amount (l /min)
1900	+1/4	+4.4

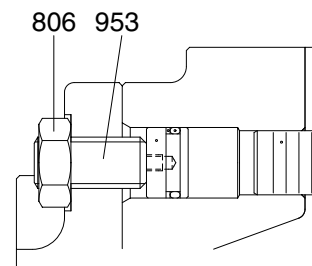

21092MP24

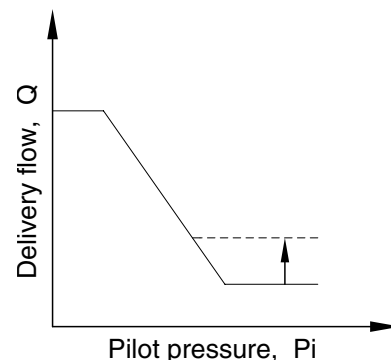

21092MP22