

GROUP 5 POWER TRAIN SYSTEM

1. POWER TRAIN MOUNTING

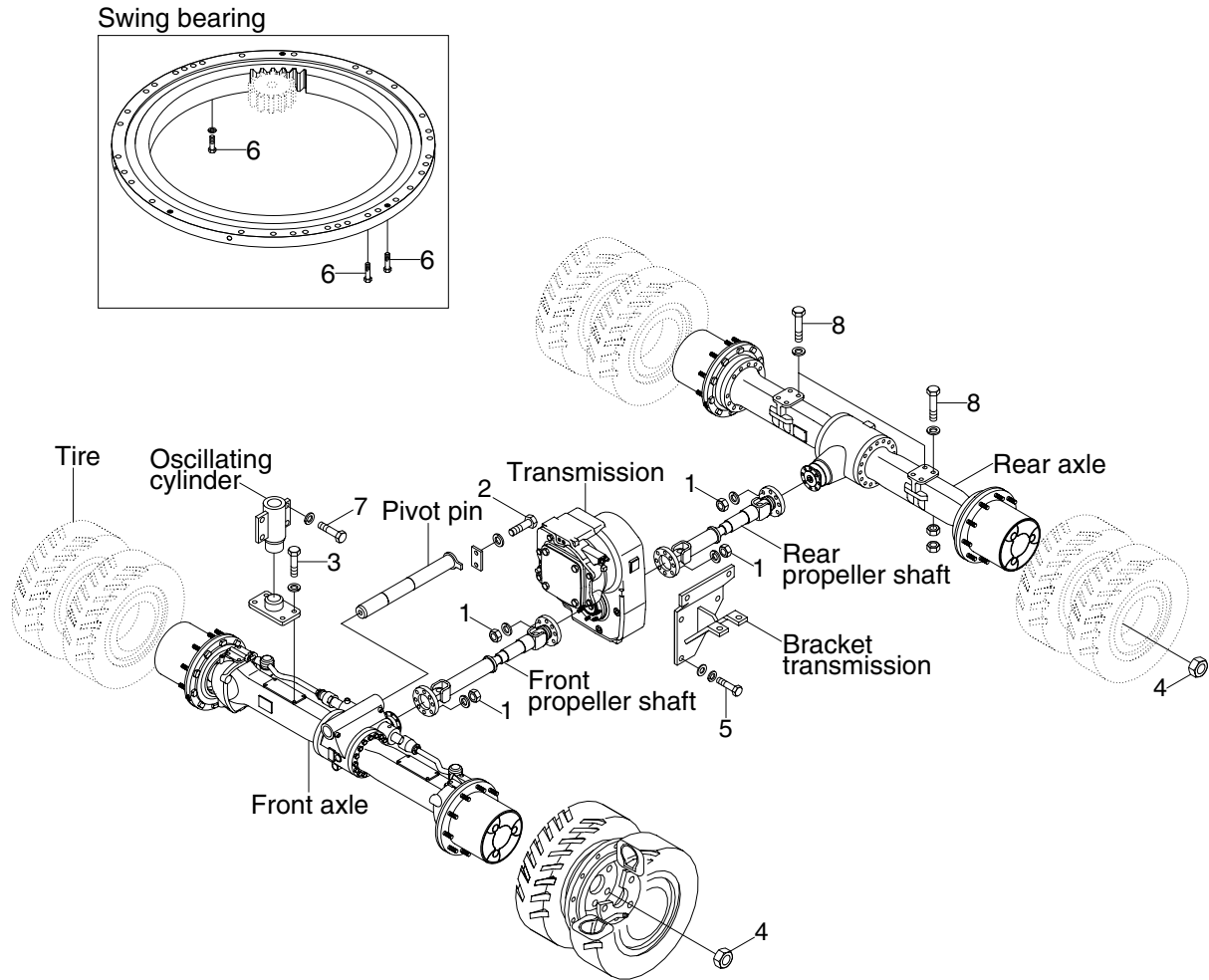

20W99CM07

· Tightening torque

Item	Size	kgf · m	kgf · m
1	M10×1.0	5.9±0.6	42.7±4.3
2	M12×1.75	12.3±2.5	89±18
3	M16×2.0	29.7±4.5	215±32.5
4	M16×1.5	60 ⁰ ₋₅	434 ⁰ _{-36.2}

Item	Size	kgf · m	kgf · m
5	M20×2.5	39±4.2	282±30.4
6	M20×2.5	57.8±6.4	418±46.3
7	M22×1.5	83.2±9.2	602±66.5
8	M24×2.0	100±10.7	723±77.4

2. COVER AND FOOT BOARD

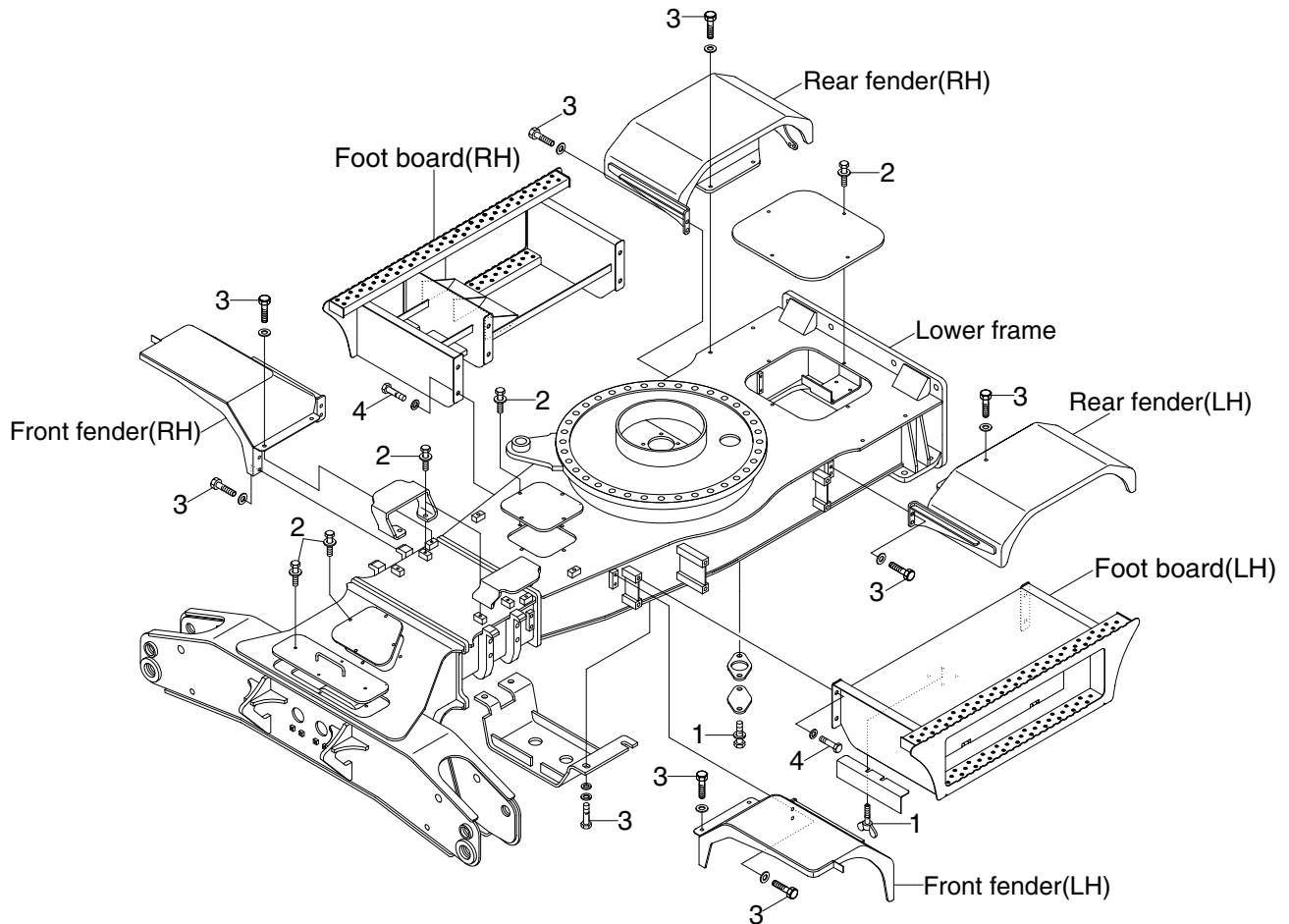

20W99CM08

· Tightening torque

Item	Size	kgf · m	kgf · m
1	M10×1.5	6.9±1.4	49.9±10.1
2	M12×1.75	12.8±3.0	92.6±21.7

Item	Size	kgf · m	kgf · m
3	M16×2.0	29.7±4.5	215±32.5
4	M20×2.5	57.9±8.7	419±62.9