

GROUP 12 TURNING JOINT

1. REMOVAL AND INSTALL

1) REMOVAL

- (1) Lower the work equipment to the ground and stop the engine.
- (2) Operate the control levers and pedals several times to release the remaining pressure in the hydraulic piping.
- (3) Loosen the breather slowly to release the pressure inside the hydraulic tank.

▲ Escaping fluid under pressure can penetrate the skin causing serious injury.

※ When pipes and hoses are disconnected, the oil inside the piping will flow out, so catch it in oil pan.

- (4) Disconnect all hoses.
- (5) Sling the turning joint assembly (1) and remove the mounting bolt (2).
 - Weight : 120 kg (265 lb)
 - Tightening torque : $12.8 \pm 3.0 \text{ kgf} \cdot \text{m}$
($92.6 \pm 21.7 \text{ lbf} \cdot \text{ft}$)

- (6) Remove the turning joint assembly.
 - ※ When removing the turning joint, check that all the hoses have been disconnected.

2) INSTALL

- (1) Carry out installation in the reverse order to removal.
 - ※ Take care of turning joint direction.
 - ※ Assemble hoses to their original positions.
 - ※ Confirm the hydraulic oil level and check the hydraulic oil leak or not.

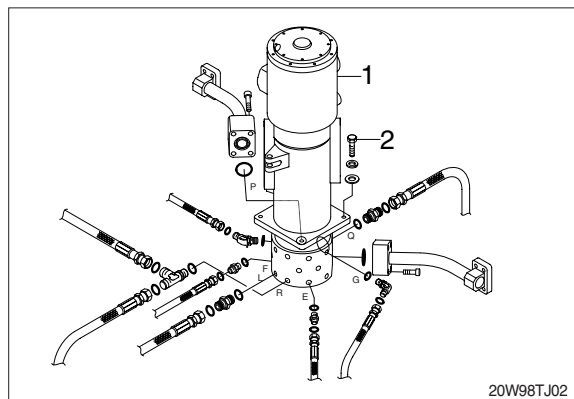
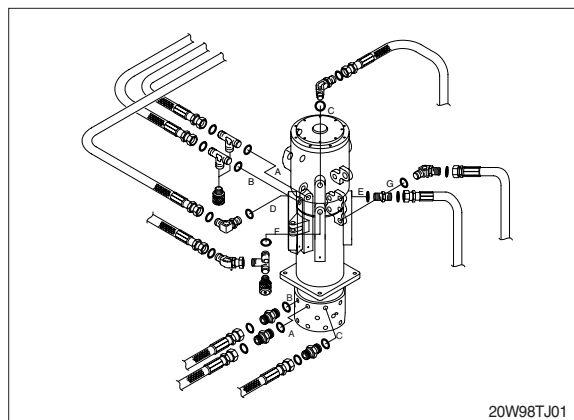

2. DISASSEMBLY AND ASSEMBLY

1) STRUCTURE

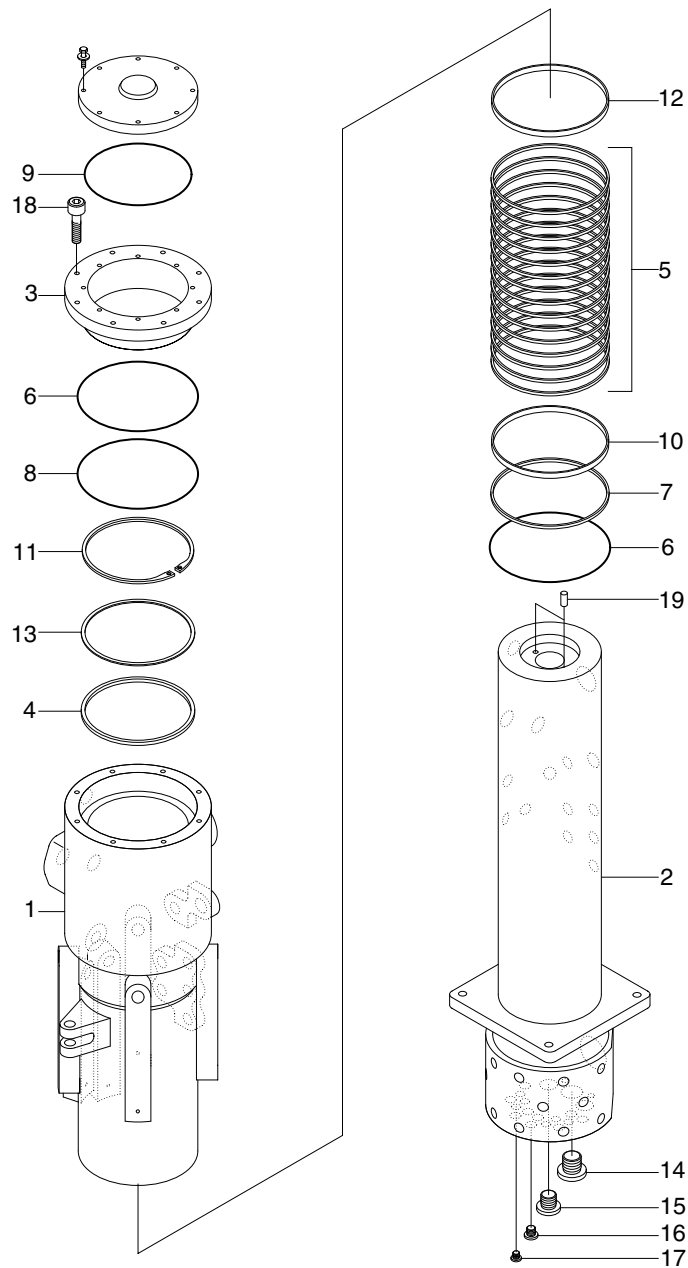

- 1 Hub
- 2 Shaft
- 3 Cover
- 4 Spacer
- 5 Slipper seal
- 6 O-ring
- 7 O-ring
- 8 O-ring
- 9 O-ring
- 10 Wear ring

- 11 Wear ring
- 12 Shim
- 13 Retaining ring
- 14 Plug
- 15 Socket plug
- 16 Plug
- 17 Plug
- 18 Socket bolt
- 19 Spring pin

20W98TJ03

2) DISASSEMBLY

※ Before the disassembly, clean the turning joint.

(1) Loosen the socket bolt (18) and remove cover (3).

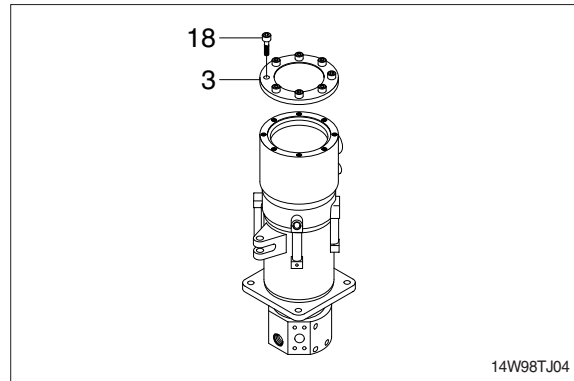

(2) Remove O-ring (8), wear ring (11), O-ring (6) and retainer ring (13) from hub (1).

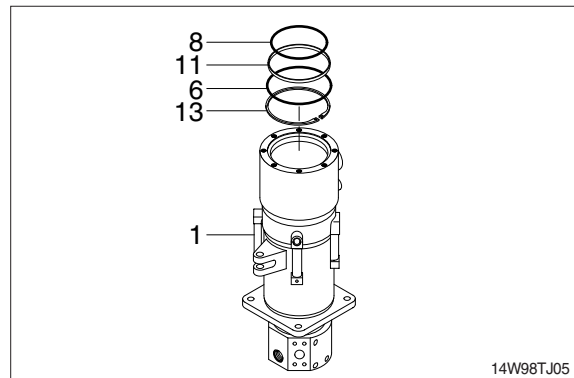

(3) Remove spacer (4) and shim (12) from hub (1).

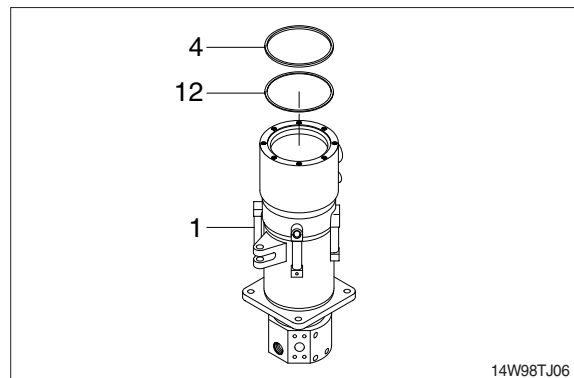

(4) Place hub (1) on a V-block and by using a wood buffer at the shaft end, hit out shaft (2) to about 1/2 from the hub with a hammer.

※ Take care not to damage the shaft (2) when remove hub (1) or rest it sideways.

※ Put a fitting mark on hub (1) and shaft (2).

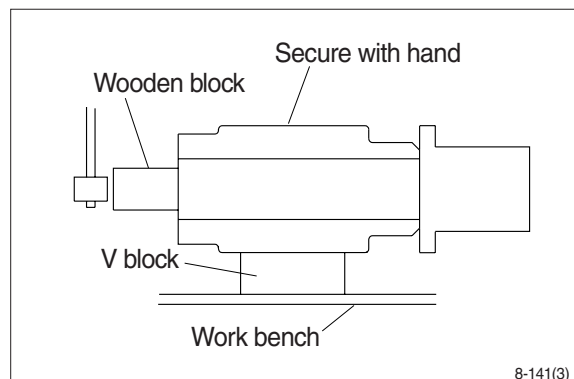

(5) Remove seventeen slipper seal (5), O-ring (6, 7) and wear ring (10) from hub (1).

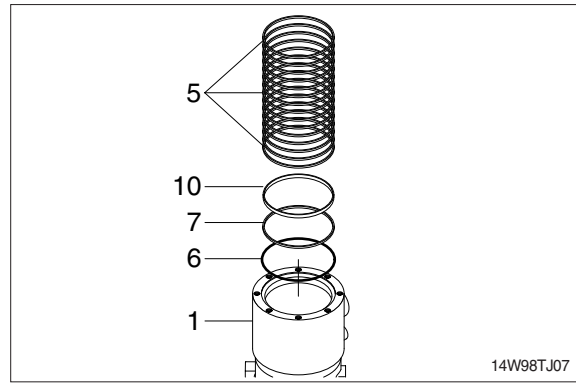

3) ASSEMBLY

- ※ Clean all parts.
- ※ As a general rule, replace oil seals and O-ring.
- ※ Coat the sliding surfaces of all parts with engine oil or grease before installing.

(1) Fit O-ring (7), seventeen slipper seal (5), and wear ring (10).

(2) Fit O-ring (6) to shaft (2).

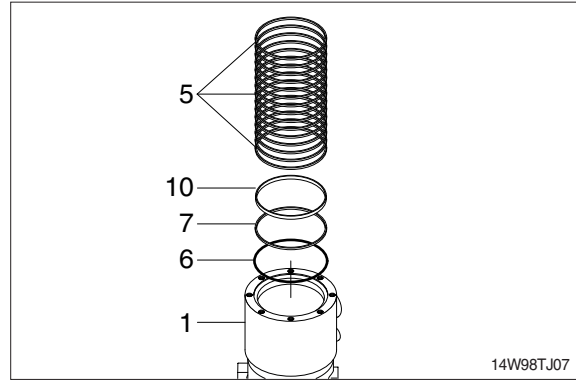

(3) Set shaft (2) on block, tap hub (1) with a plastic hammer to install.

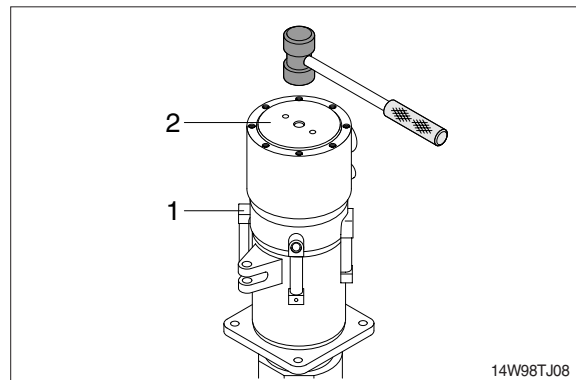

(4) Fit shim (12), and spacer (4) to hub (1) of turning joint upside.

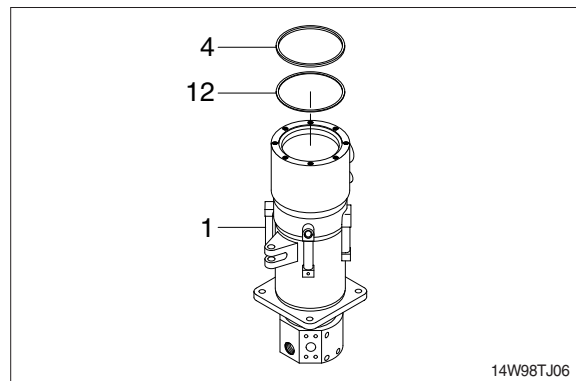

- (5) Fit retainer ring (13), O-ring (6) and wear ring (11) to shaft (2).
- (6) Fit O-ring (8) to hub (1).

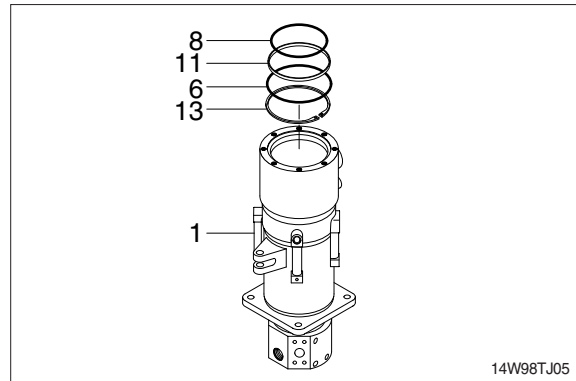

- (7) Install cover (3) to hub and tighten bolts (18).
- Torque : $2.35 \pm 0.35 \text{ kgf} \cdot \text{m}$
($17.0 \pm 2.5 \text{ lbf} \cdot \text{ft}$)

