

GROUP 2 MODE SELECTION SYSTEM

1. POWER MODE SELECTION SYSTEM

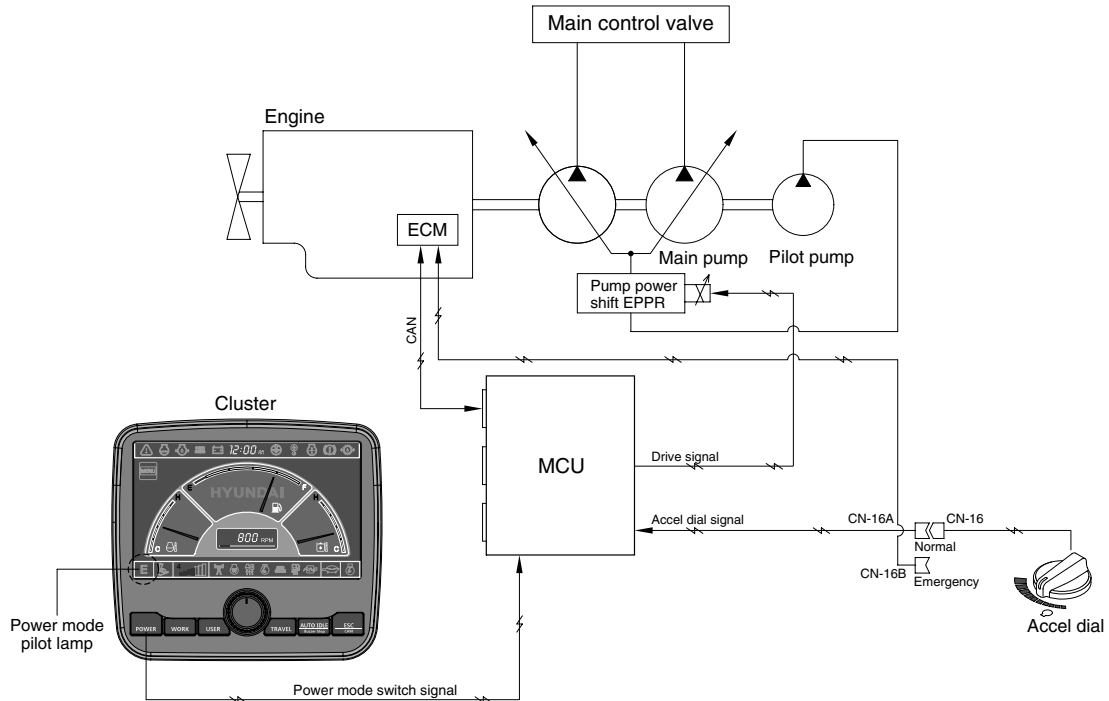

14W95MS02

Mode selection system (micro computer based electro-hydraulic pump and engine mutual control system) optimizes the engine and pump performance.

The combination of 3 power modes (P, S, E) and accel dial position (10 set) makes it possible to use the engine and pump power more effectively corresponding to the work conditions from a heavy and great power requesting work to a light and precise work.

Power mode	Application	Engine rpm				Power shift by EPPR valve			
		Standard		Option		Standard		Option	
		Unload	Load	Unload	Load	Current (mA)	Pressure (kgf/cm ²)	Current (mA)	Pressure (kgf/cm ²)
P	Heavy duty power	1700±50	1650±50	1700±50	1650±50	260±30	5	160±30	0
S	Standard power	1500±50	1450±50	1500±50	1450±50	330±30	9±3	260±30	5±3
E	Economy operation	1350±50	1450±50	1350±50	1450±50	380±30	14±3	320±30	10±3
AUTO DECEL	Engine deceleration	1000±100	-	1000±100	-	700±30	38±3	700±30	38±3
One touch decel	Engine quick deceleration	850±100	-	850±100	-	700±30	38±3	700±30	38±3
KEY START	Key switch start position	850±100	-	850±100	-	700±30	38±3	700±30	38±3

※ Power shift (Standard/Option) can be changed by "Service menu" in "Management" on the cluster.

2. WORK MODE SELECTION SYSTEM

Work mode consists of the general operation (bucket) and the optional attachment (breaker, crusher).

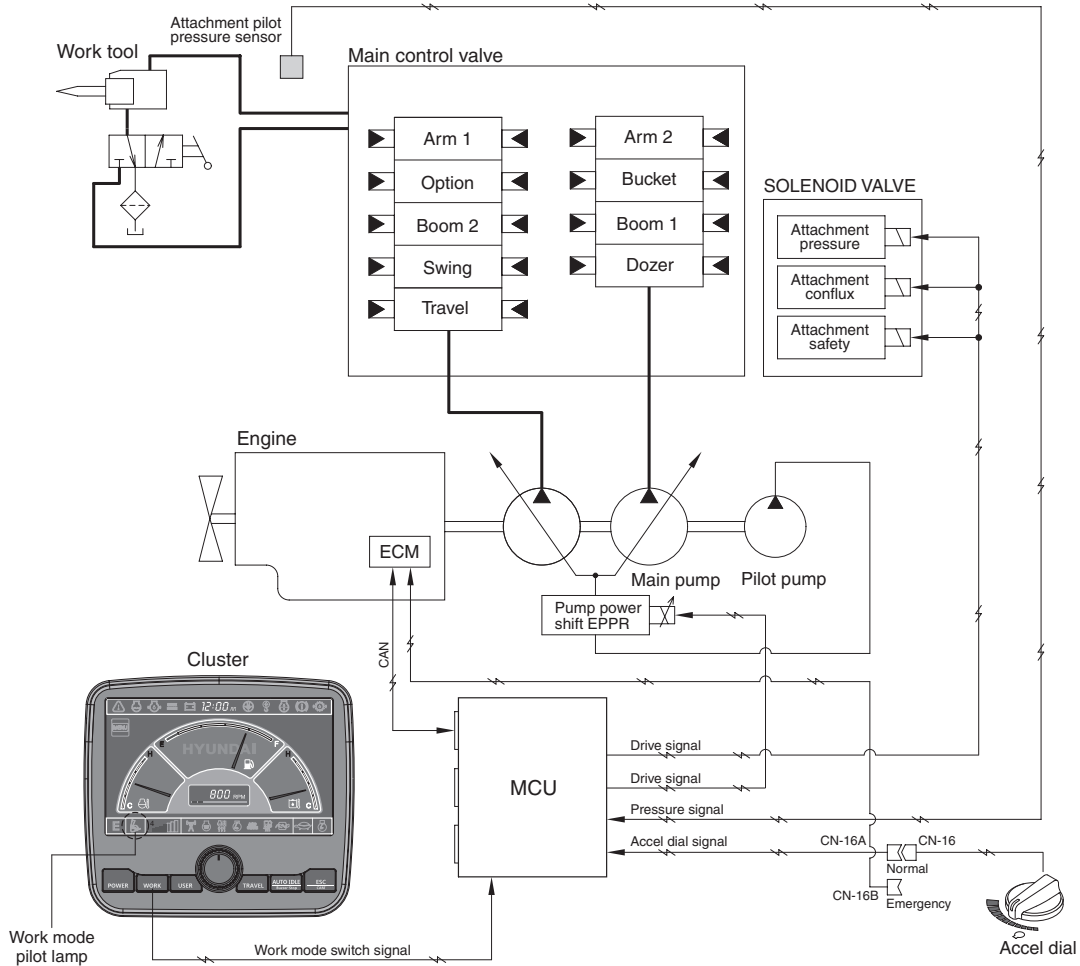

20W95MS03

1) GENERAL WORK MODE (bucket)

This mode is used to general digging work.

2) ATT WORK MODE (breaker, crusher)

It controls the pump flow and system pressure according to the operation of breaker or crusher.

Description	General mode	Work tool	
	Bucket	Breaker	Crusher
Attachment safety solenoid	OFF	ON	ON
Attachment pressure solenoid	OFF	OFF	ON
Attachment conflux solenoid	OFF	OFF	ON/OFF
Attachment flow EPPR current	100 mA	100~700 mA	100~700 mA

3. USER MODE SELECTION SYSTEM

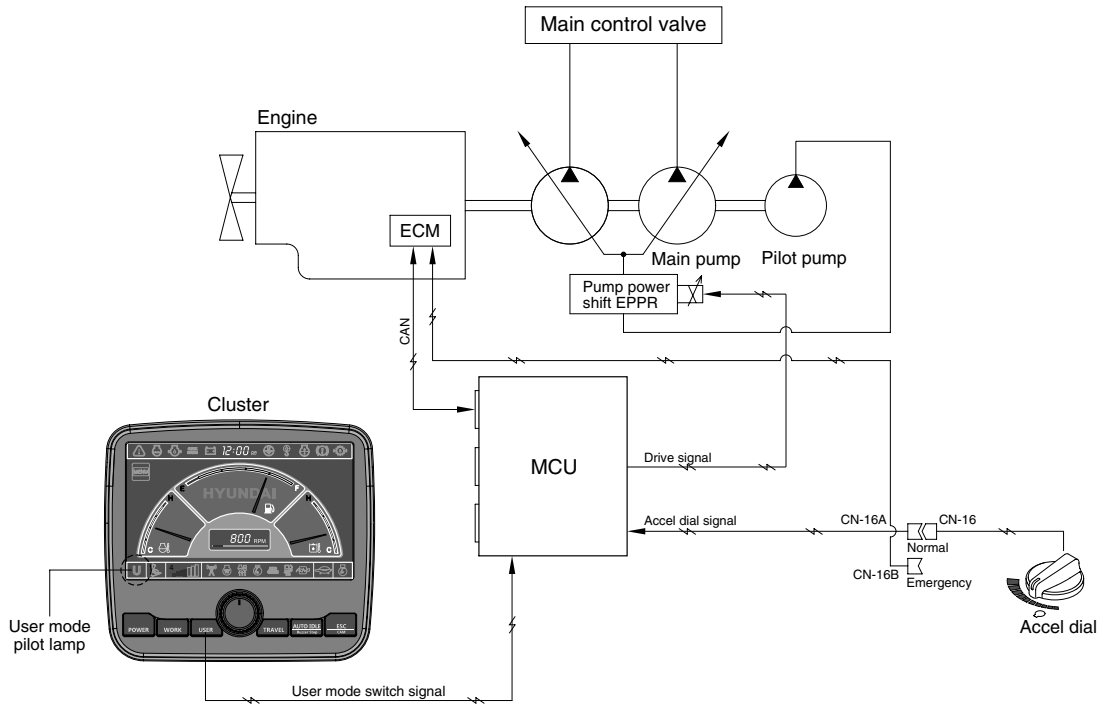

14W95MS03A

1) High idle rpm, auto idle rpm and EPPR pressure can be adjusted and memorized in the U-mode.

2) LCD segment vs parameter setting

Step ()	Engine speed (rpm)	Idle speed (rpm)	Power shift (bar)
1	1250	700	0
2	1300	750	3
3	1350	800	6
4	1400	850 (low idle)	9
5	1450	900	12
6	1500	950	16
7	1550	1000 (decel rpm)	20
8	1600	1050	26
9	1650	1100	32
10	1700	1150	38