

GROUP 3 PILOT CIRCUIT

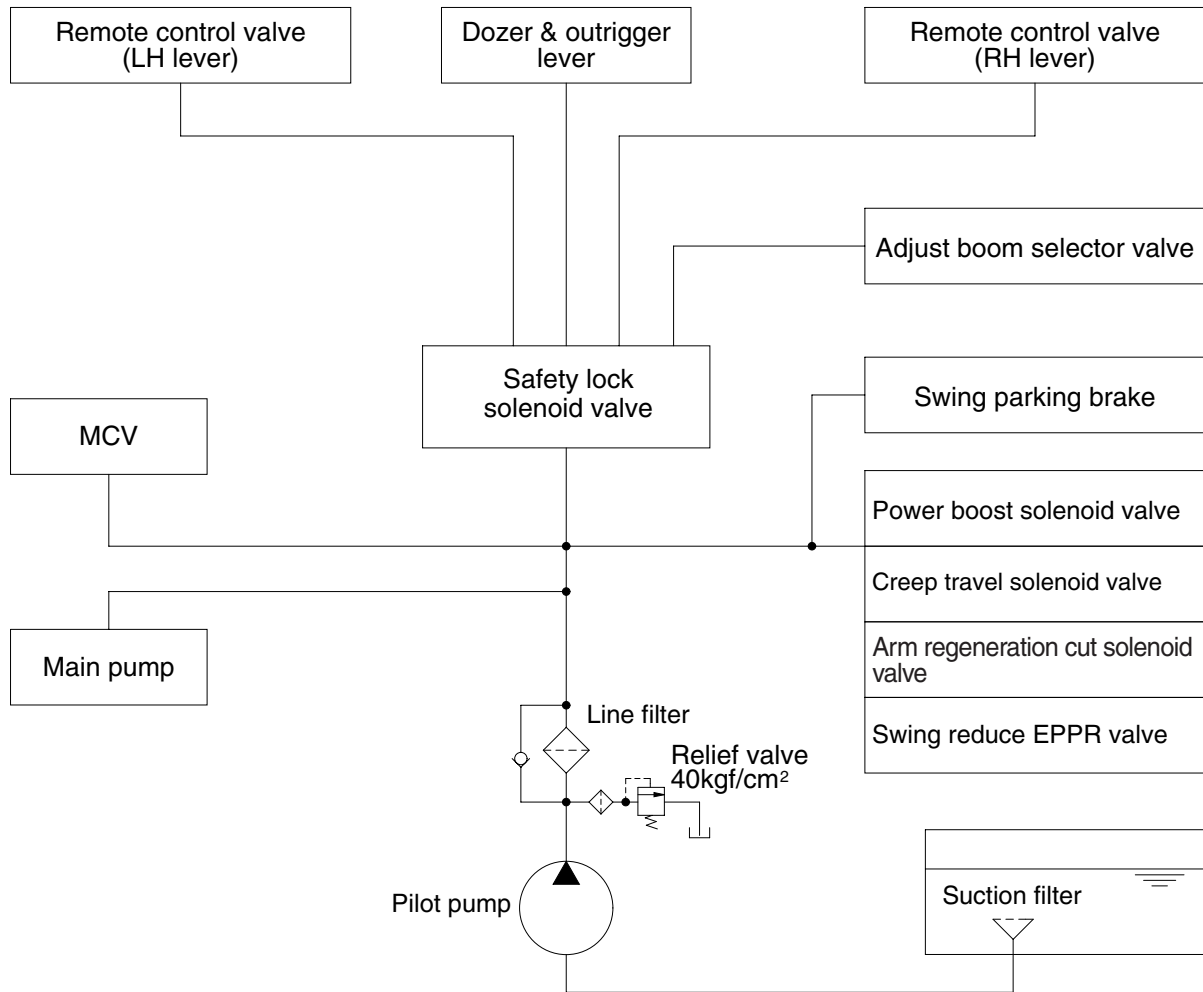

20W93CI01

The pilot circuit consists of suction circuit, delivery circuit and return circuit.

The pilot pump is provided with relief valve, receives the oil from the hydraulic tank through the suction filter.

The discharged oil from the pilot pump flows to the remote control valve, EPPR valve, solenoid valve assemblies, swing parking brake, main control valve and safety lock solenoid valve through line filter.

1. SUCTION, DELIVERY AND RETURN CIRCUIT

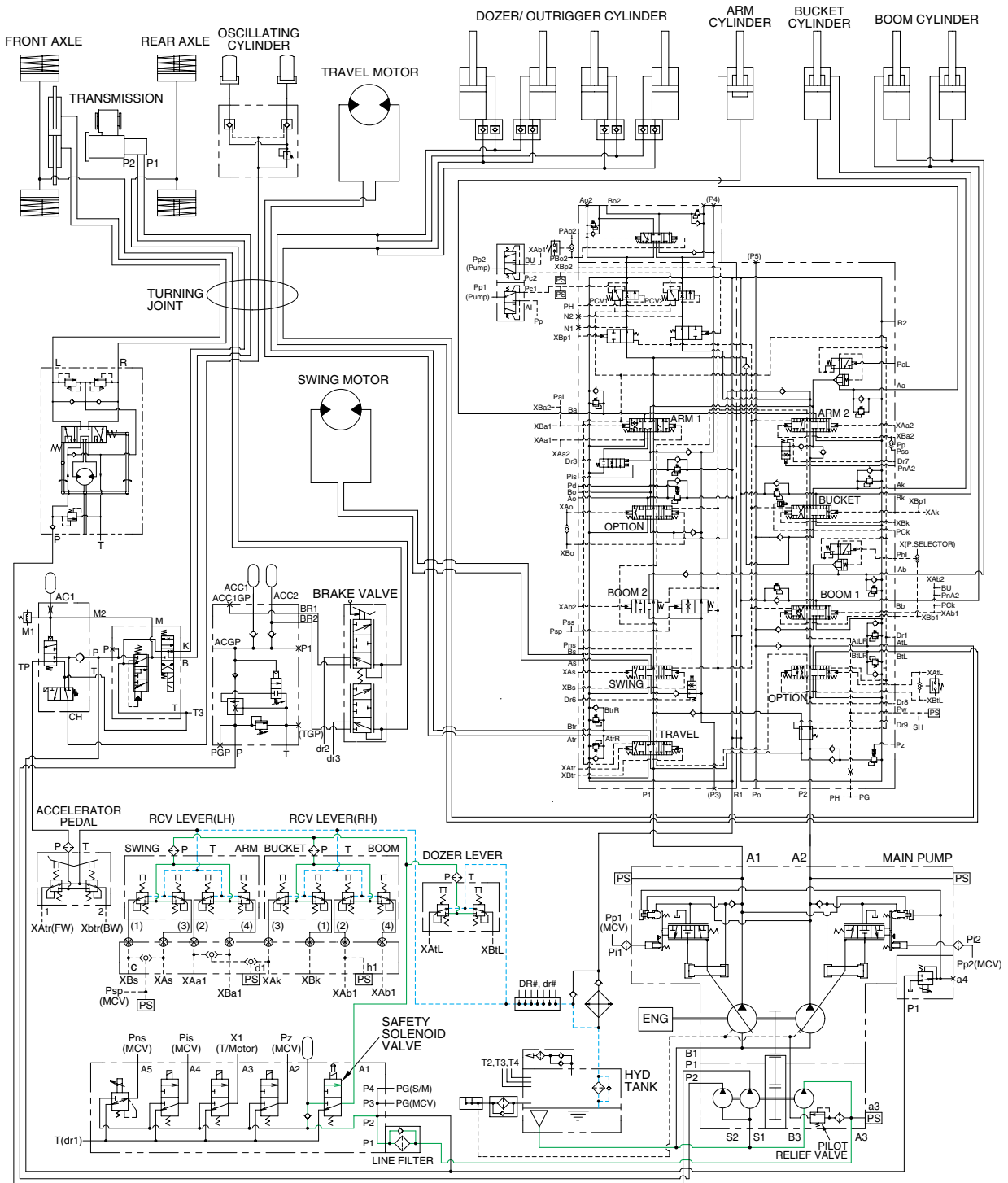

20W93HC02

The pilot pump receives oil from the hydraulic tank. The discharged oil from the pilot pump flows to the safety solenoid valve through the line filter. The oil is filtered by the line filter. The pilot relief valve is provided in the pilot pump for limiting the pilot circuit pressure.

The oil filtered by line filter flows remote control valve through safety solenoid valve.

The return oil from remote control valve is returned to the hydraulic tank.

2. SAFETY SOLENOID VALVE (SAFETY LEVER)

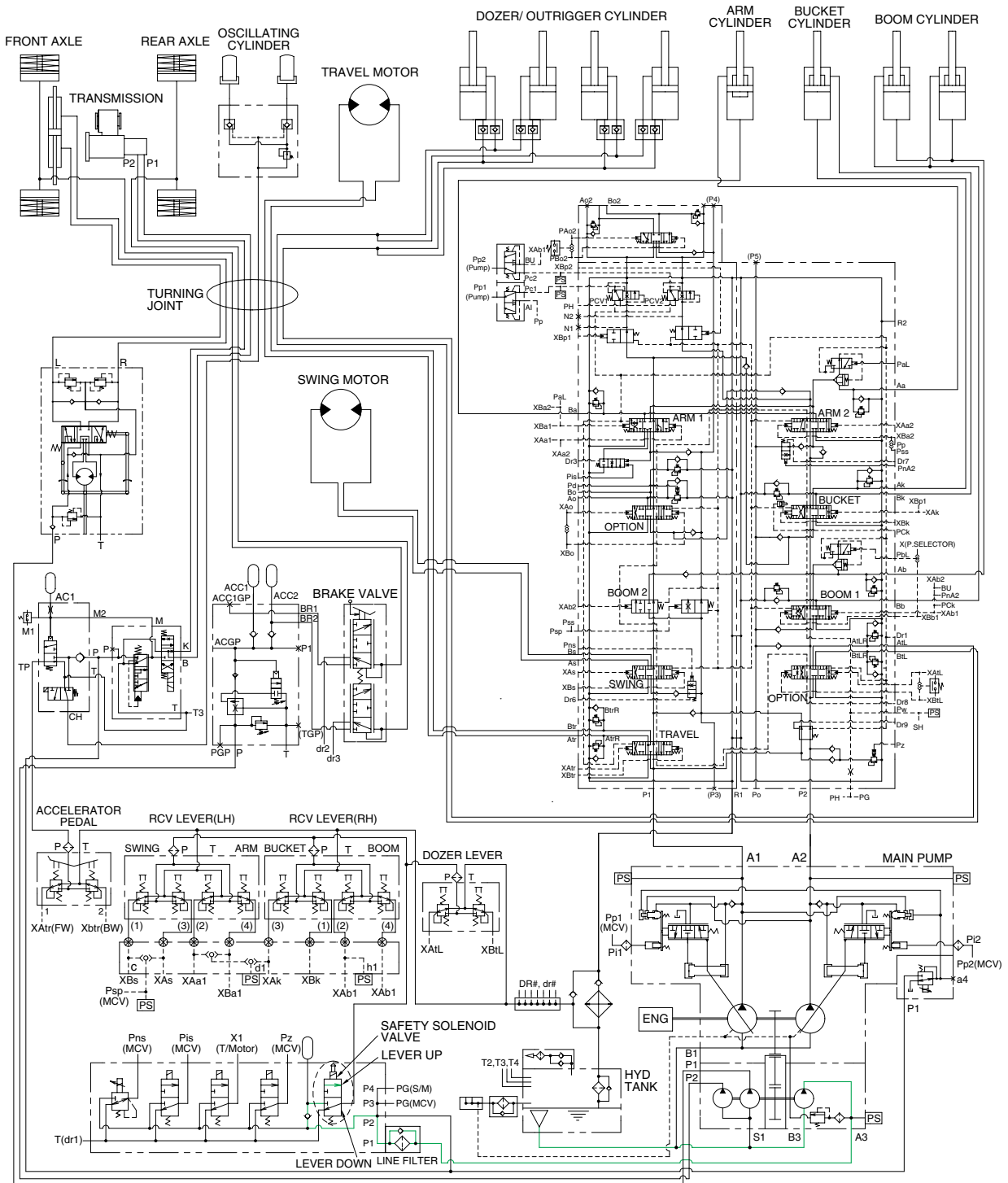

20W93HC03

When the lever of the safety solenoid valve is moved upward, oil flows into the remote control valve through solenoid valve and line filter.

When the lever of the safety solenoid valve moved downward, oil does not flows into the remote control valve, because of blocked port.

3. MAIN RELIEF PRESSURE CHANGE SYSTEM

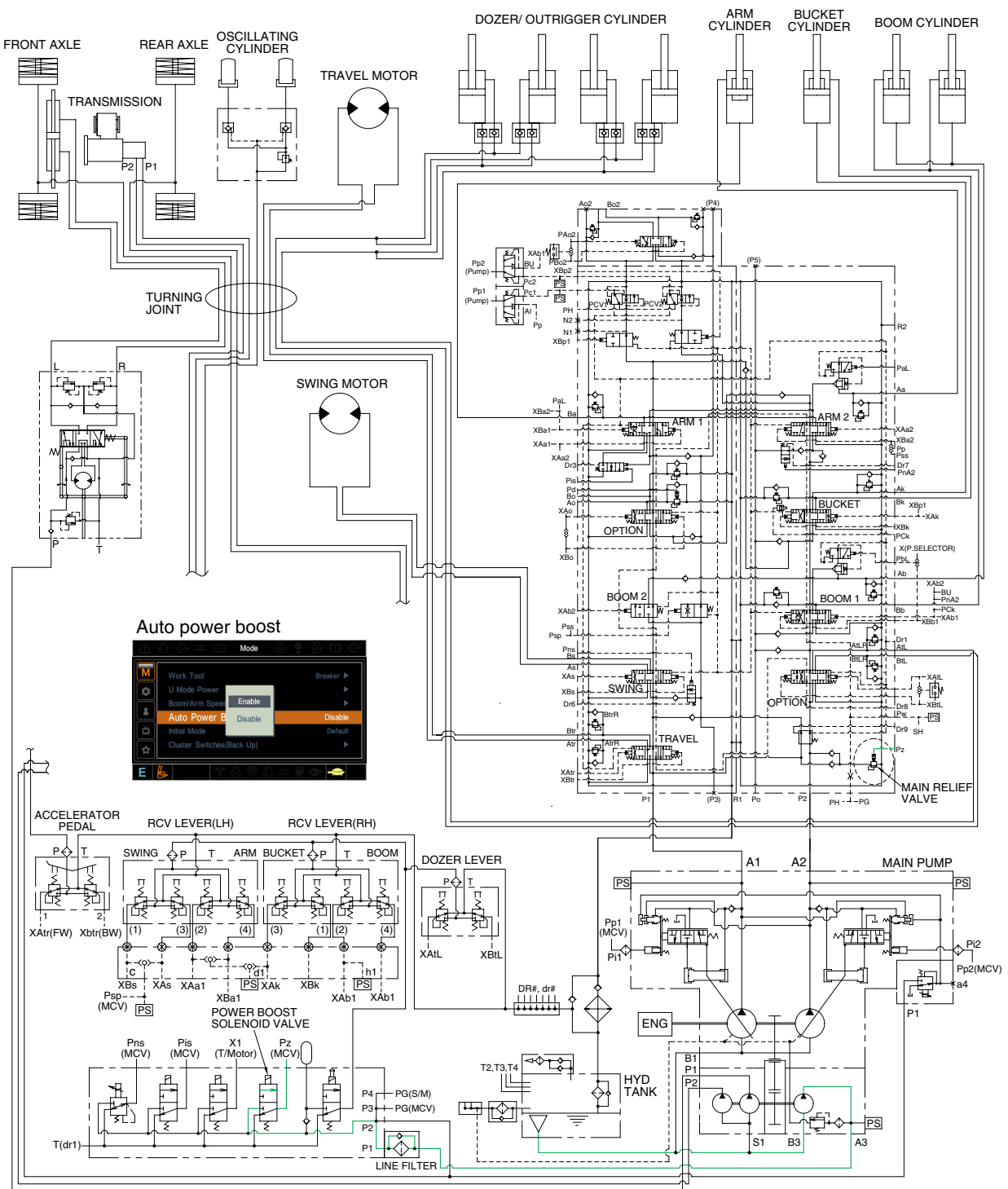

20W93HC04A

When the power boost switch on the left control lever is pushed ON, the power boost solenoid valve is actuated, the discharged oil from the pilot pump flows into **Pz** port of the main relief valve in main control valve ; then the setting pressure of the main relief valve is raises from 350 kgf/cm² to 380 kgf/cm² for increasing the digging power. And even when press continuously, it is canceled after 8 seconds.

When the auto power boost function is selected to enable on the cluster, the pressure of the main relief pressure is automatically increased to 380 kgf/cm² as working condition by the MCU. It is also operated max 8 seconds.

4. SWING PARKING BRAKE RELEASE

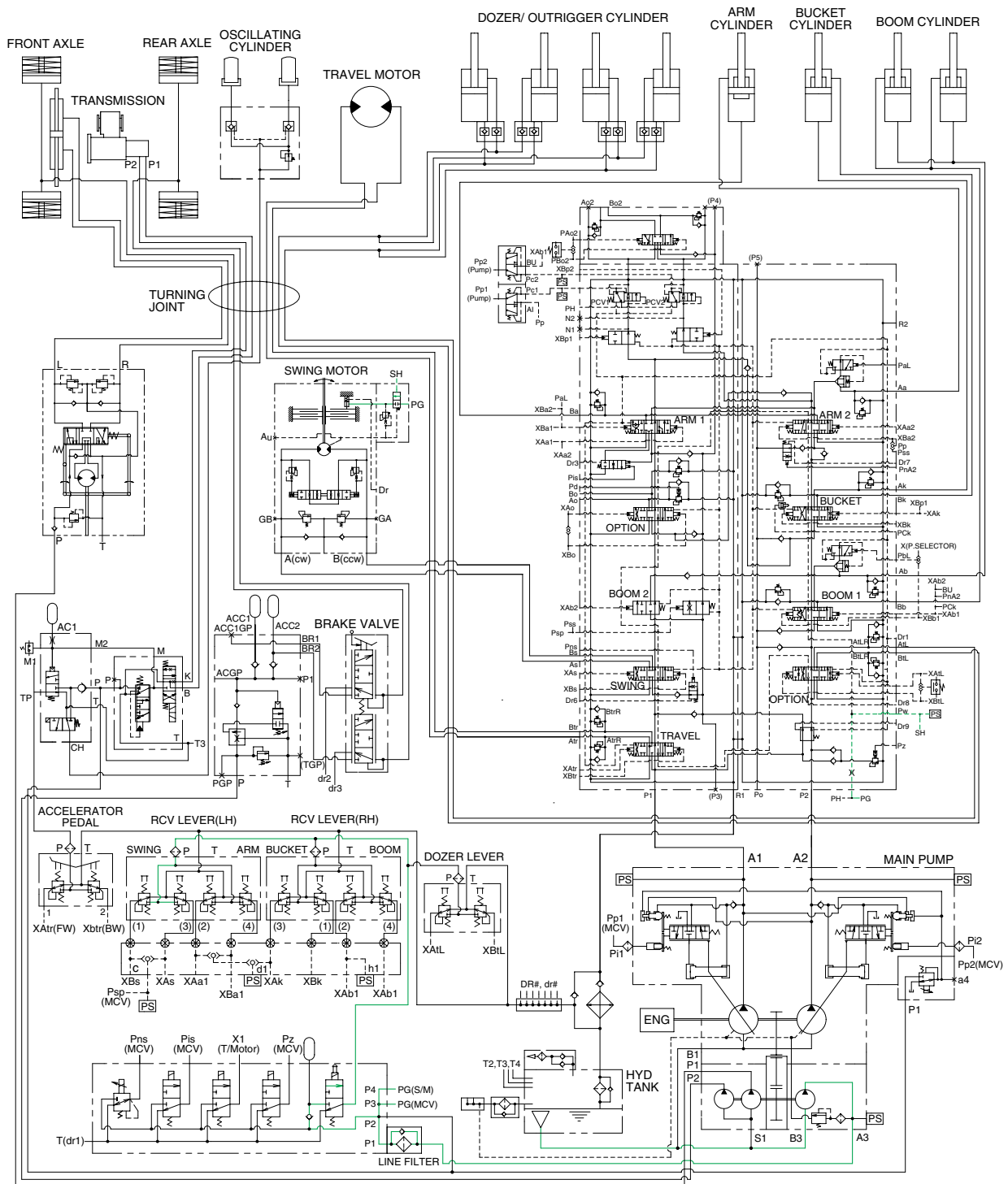

20W93HC05

When one of the RCV lever is tilted, the pilot oil flows into SH port through main control valve. This pressure move spool so, discharged oil from pilot pump flows into swing motor PG port. This pressure is applied to swing motor disc, thus the brake released.

When the all of the RCV lever are set in the neutral position, oil in the swing motor disc cylinder is drained, thus the brake is applied.

5. TRAVEL SPEED SELECTION SYSTEM

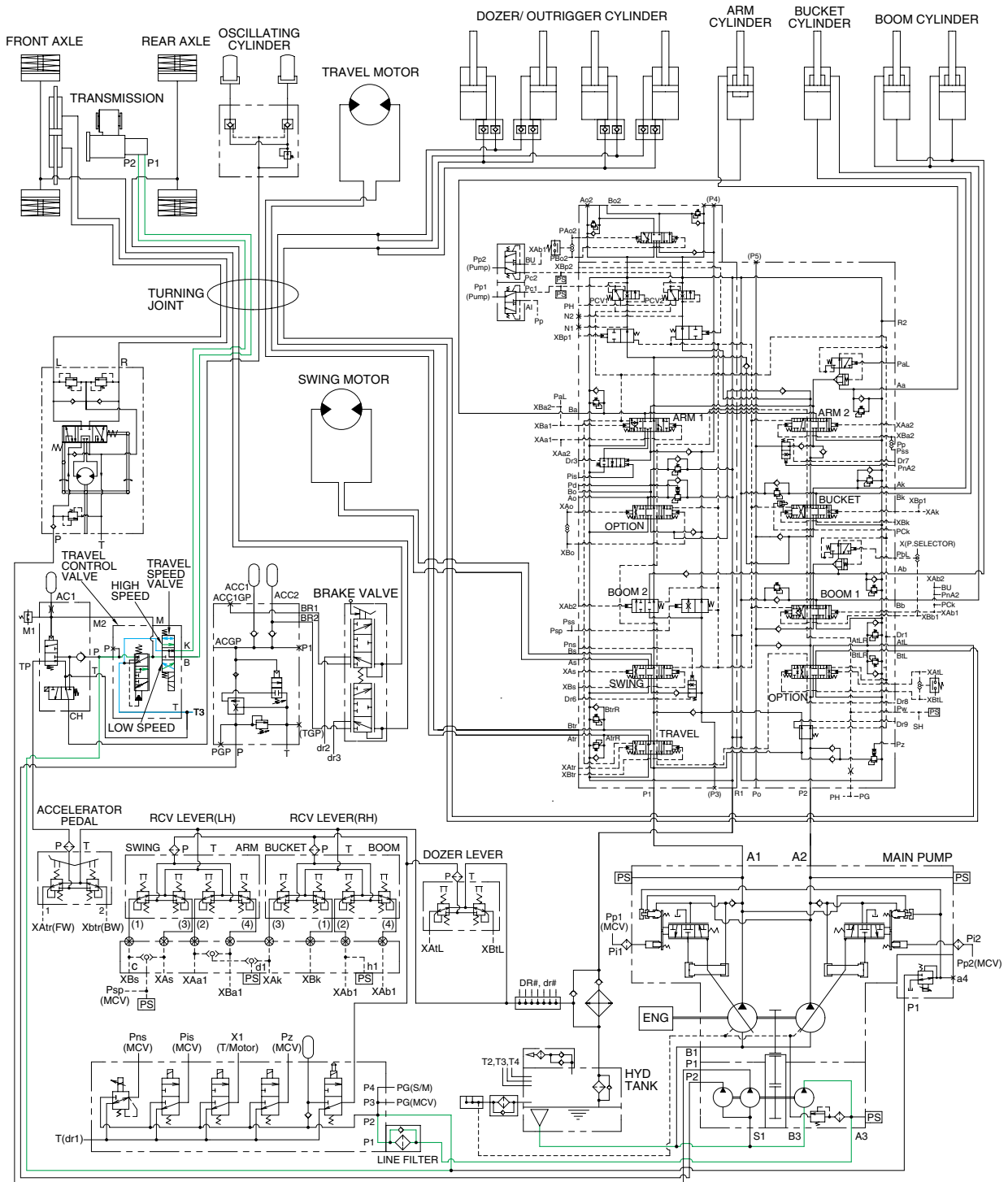

20W93HC06

When RH multifunction switch was placed in high or low speed position, the pressure oil from pilot pump flows to travel speed solenoid valve through travel control valve, thus the transmission is changed into high (P1) or low (P2) speed condition.

6. CREEP TRAVEL SYSTEM

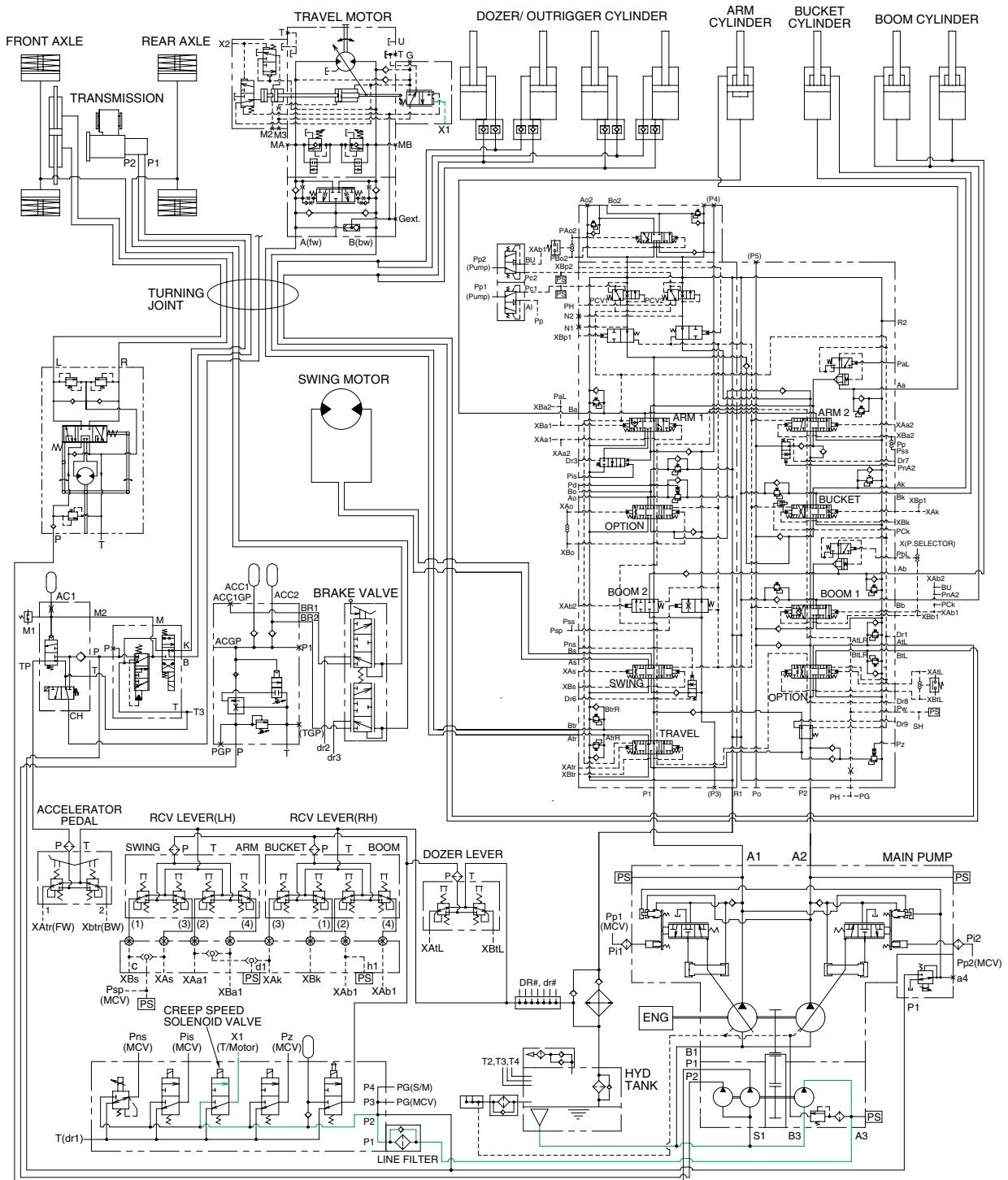

20W93HC07

When the creep switch behind the accel dial is pushed ON, the creep travel solenoid valve is actuated.

The discharged oil from the pilot pump flows into X1 port of travel motor through solenoid valve.

Then, the machine speed is very low travelling more than 1st speed.

7. ARM REGENERATION CUT SYSTEM

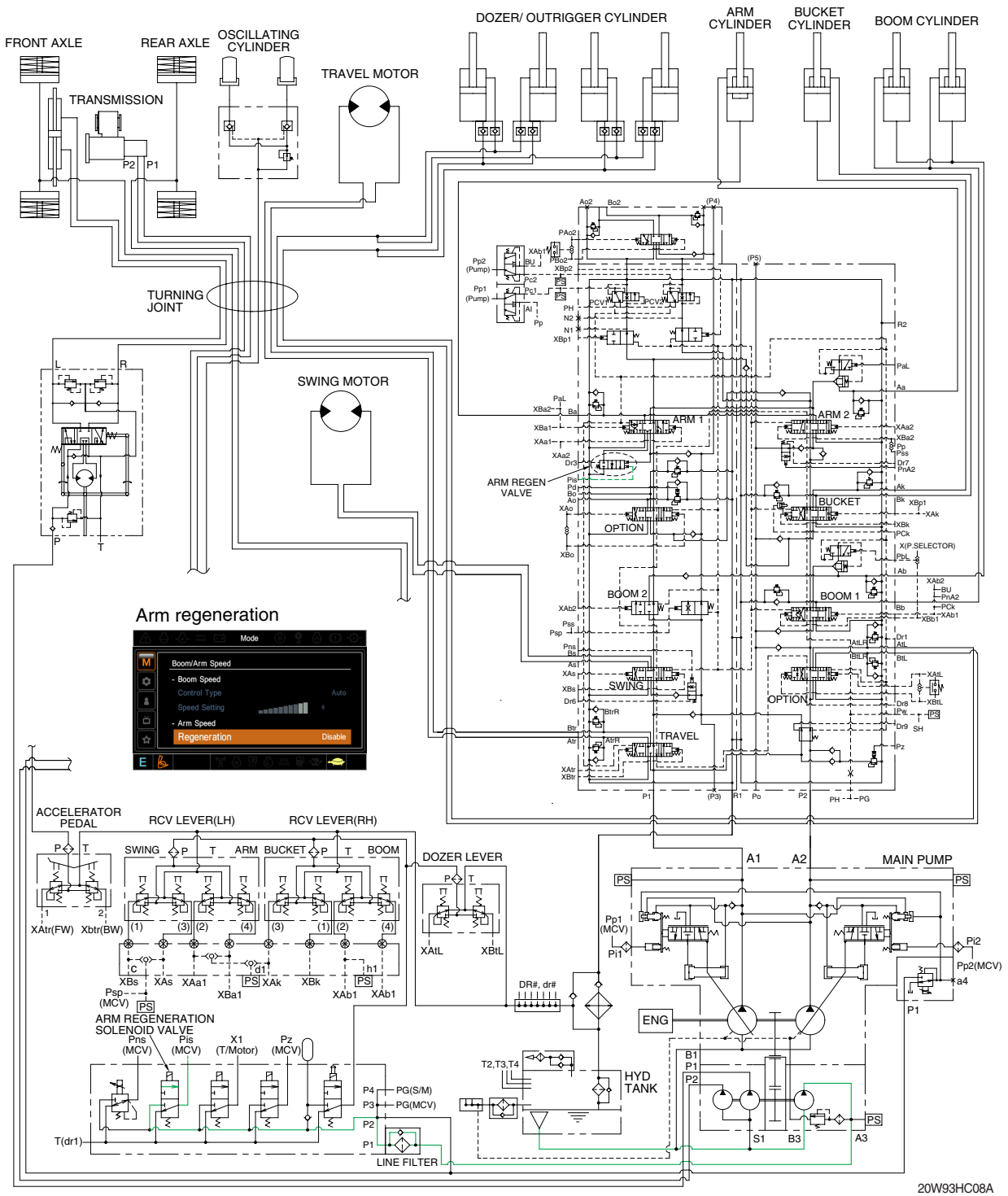

20W93HC08A

When the arm regeneration is selected to disable on the cluster, the arm regeneration solenoid valve is activated. The pilot oil from pilot pump flows into **Pis** port in main control valve through solenoid valve and the arm regeneration spool is shifted to left.

Then, the oil from arm regeneration passage returns to tank and the arm regeneration function is deactivated.

When the arm regeneration is selected to enable on the cluster, the arm regeneration function is activated and arm in operation speed is increased.

Refer to page 2-30 for the arm regeneration function.

