

GROUP 2 MAIN CONTROL VALVE

1. STRUCTURE

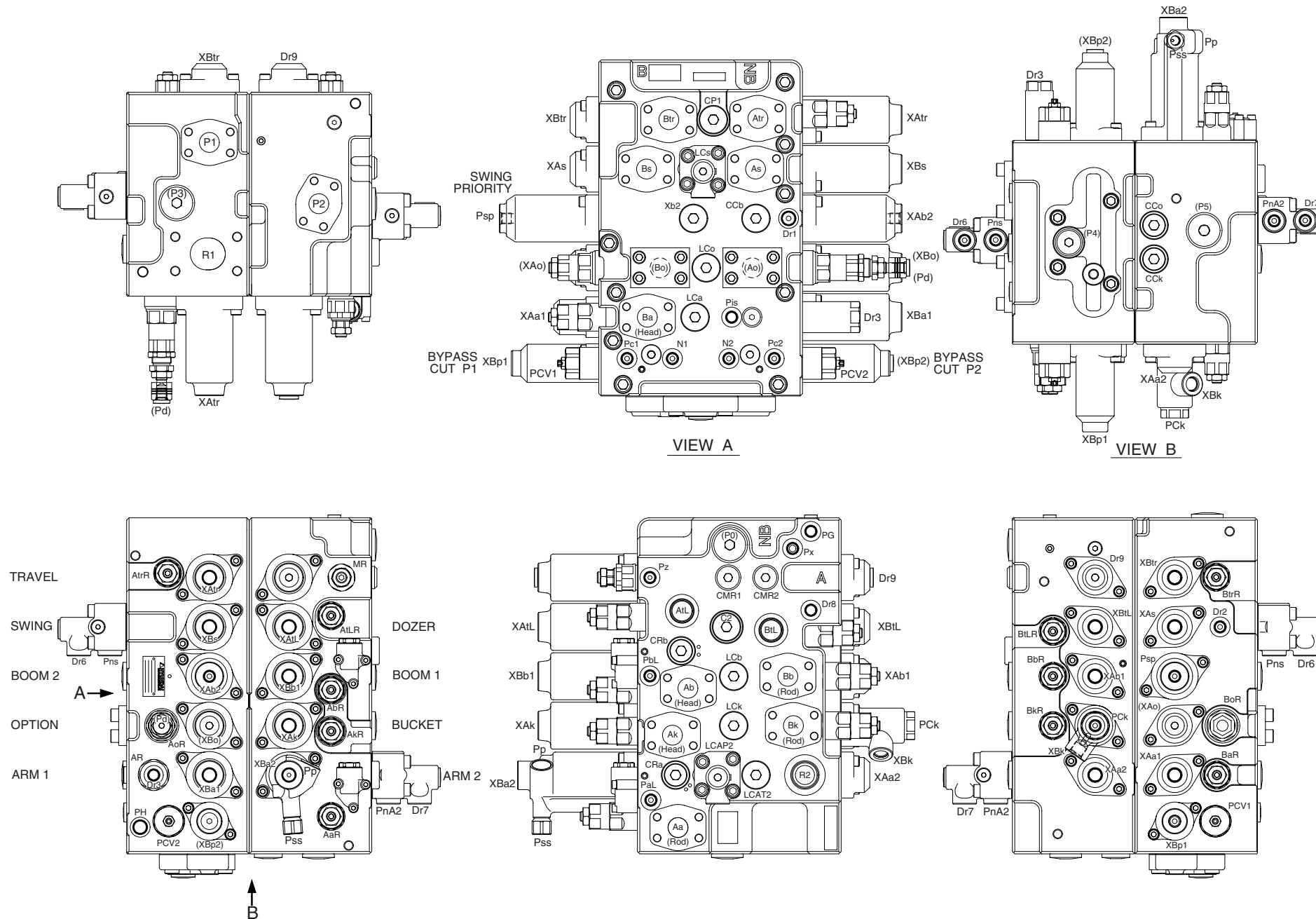

Mark	Port name	Port size	Tightening torque
R2	Make up port for swing	PF 1	20~25 kgf · m (115~180 lbf · ft)
XAtr XBtr (XAo) (XBo) XAk XBk XAb1 XBb1 XAa2 XBa2 XAtrL XBtrL XAs XBs XAa1 XBa1 PH Dr1 Dr9	Travel forward pilot port Travel reverse pilot port Optional pilot port Optional pilot port Bucket in pilot port Bucket out pilot port Boom up pilot port Boom down pilot port Arm out confluence pilot port Arm in confluence pilot port Dozer down pilot port Dozer up pilot port Swing right pilot port Swing left pilot port Arm out pilot port Arm in pilot port Pilot pressure port Drain port Drain port	PF 3/8	7~8 kgf · m (50.6~57.8 lbf · ft)
Pw Dr8 Pz PG Dr2 Dr3 Dr6 Dr7 Pns PaL PbL XAb2 Psp XBp1 (XBp2) (Pd) Pc1 Pc2 PCK Pis (N1) (N2) PnA2 Pss Pp	Pressure port for auto idle signal Drain port Main relief set pressure up pilot pressure port Pilot pressure port Drain port Drain port Drain port Drain port Swing logic valve pilot port Lock valve pilot port (arm rod side) Lock valve pilot port (boom head side) Boom up confluence pilot port Swing priority pilot port Bypass cut spool pilot port (P1 side) Bypass cut spool pilot port (P2 side) Opt P/relief set pressure up pilot pressure port Posi-nega pressure port (P1 side) Posi-nega pressure port (P2 side) Bucket in stroke limiter pilot port Arm regeneration cut pilot port Nega-con pressure port (P1 side) Nega-con pressure port (P2 side) Arm2 logic valve pilot port Shuttle-swing pilot pressure port Shuttle-swing or arm in pressure port	PF 1/4	3.5~3.9 kgf · m (25.3~28.2 lbf · ft)
Atr Btr (Ao) (Bo) Ak Bk Ab Bb As Bs Aa Ba P1 P2	Travel forward port Travel reverse port Optional port Optional port Bucket cylinder head side port Bucket cylinder rod side port Boom cylinder head side port Boom cylinder rod side port Swing motor right port Swing motor left port Arm cylinder rod side port Arm cylinder head side port Pump port (P1 side) Pump port (P2 side)	M10	5~6.6 kgf · m (36.1~47.7 lbf · ft)
R1	Return port	M12	8.5~11.2 kgf · m (61.5~81.1 lbf · ft)
AtL BtL (P0) (P3) (P5)	Dozer cylinder head side port Dozer cylinder rod side port Quick clamp solenoid valve supply port - -	PF 3/4	15.3~18.4 kgf · m (110.6~133 lbf · ft)
(P4)	-	PF 1/2	10~12.2 kgf · m (72.3~88.2 lbf · ft)

20W92MC01A

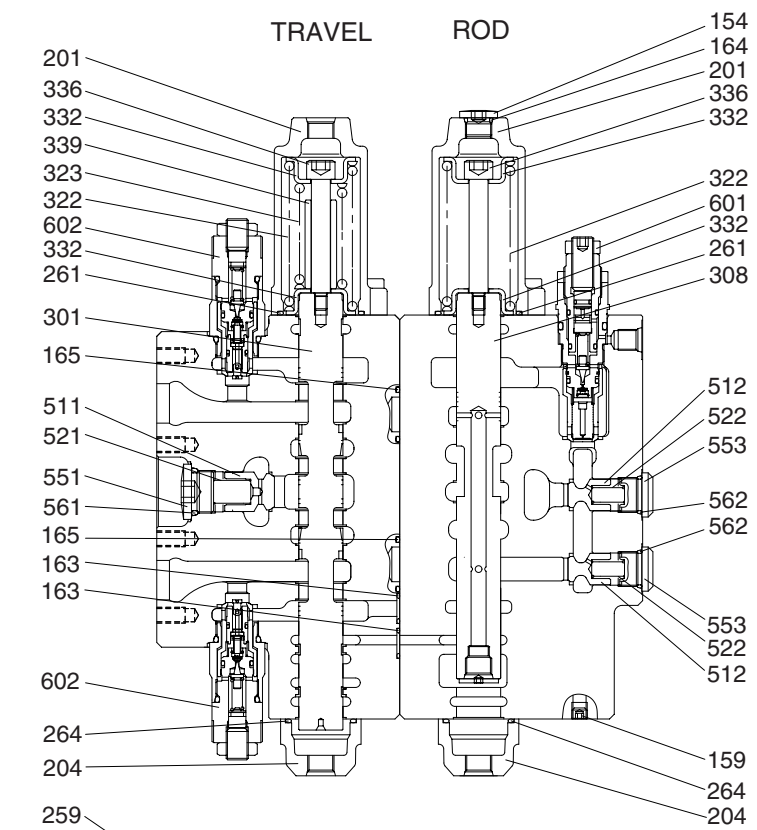

SECTION C-C

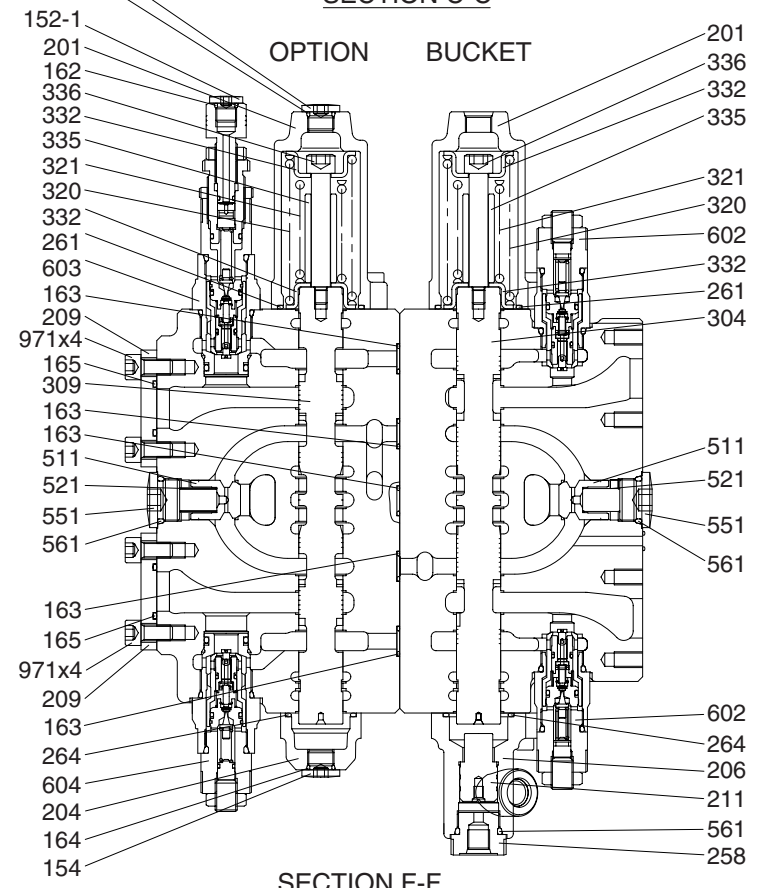

SECTION F-F

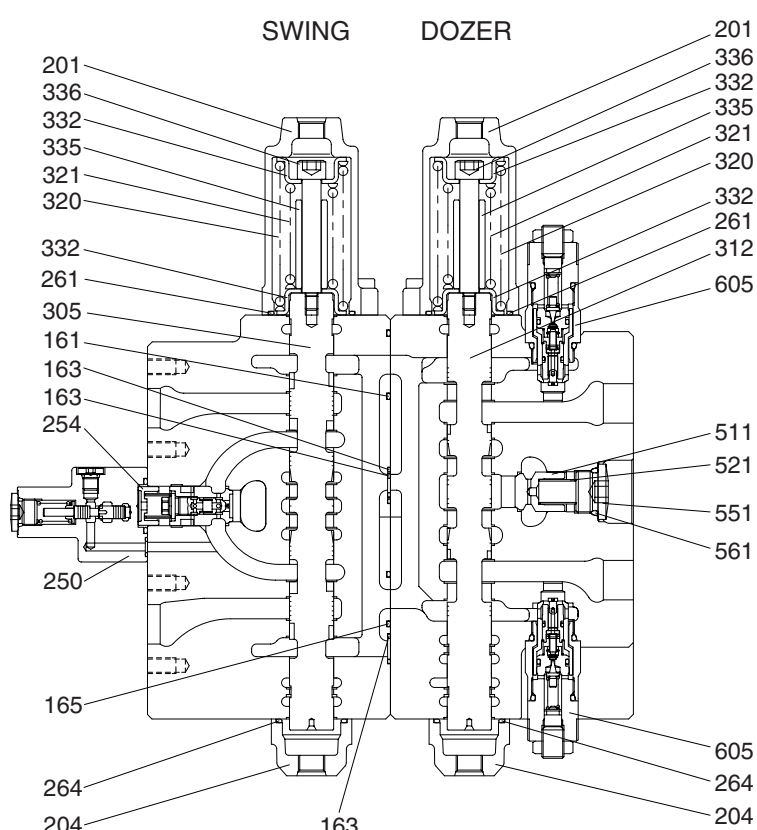

SECTION D-D

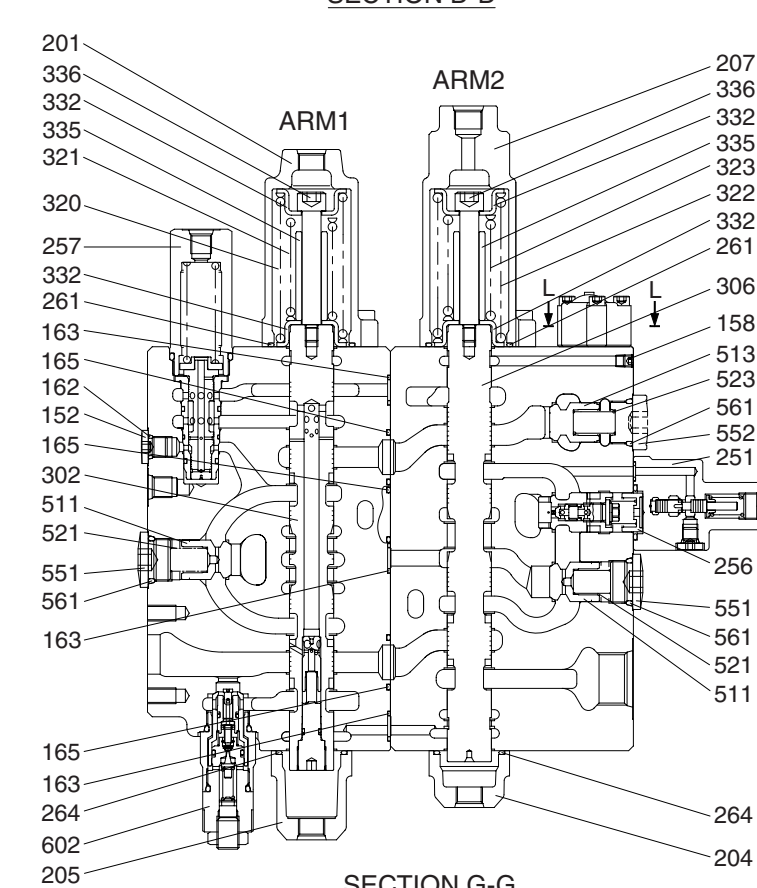

SECTION G-G

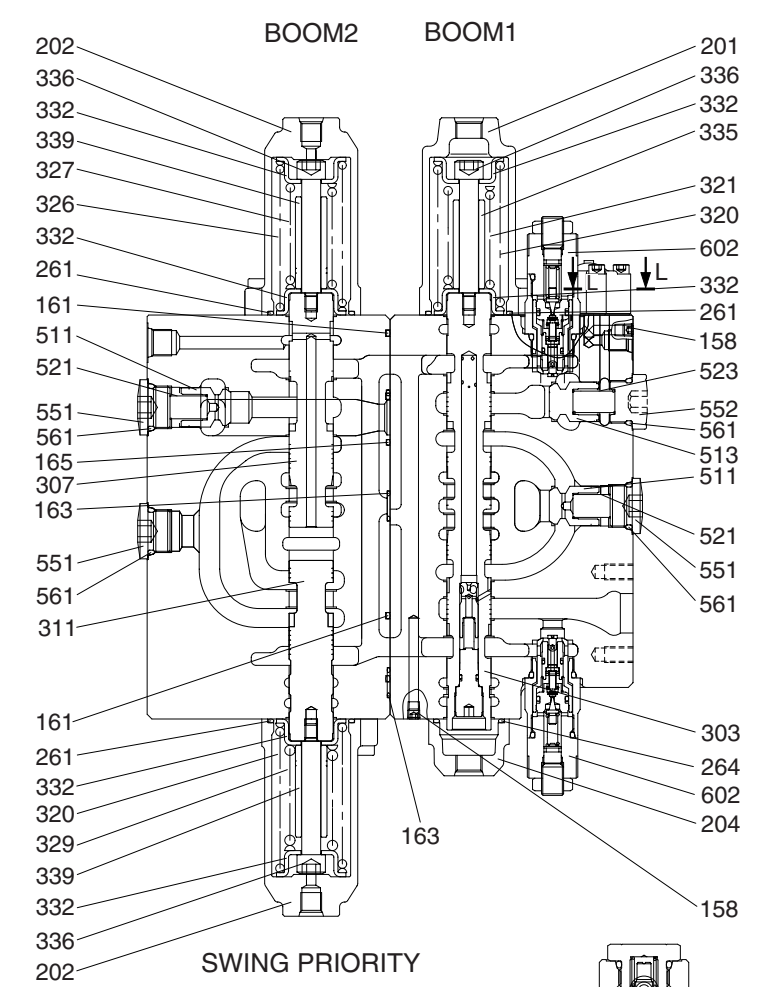

SWING PRIORITY

SECTION E-E

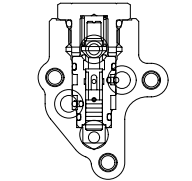

SECTION L-L

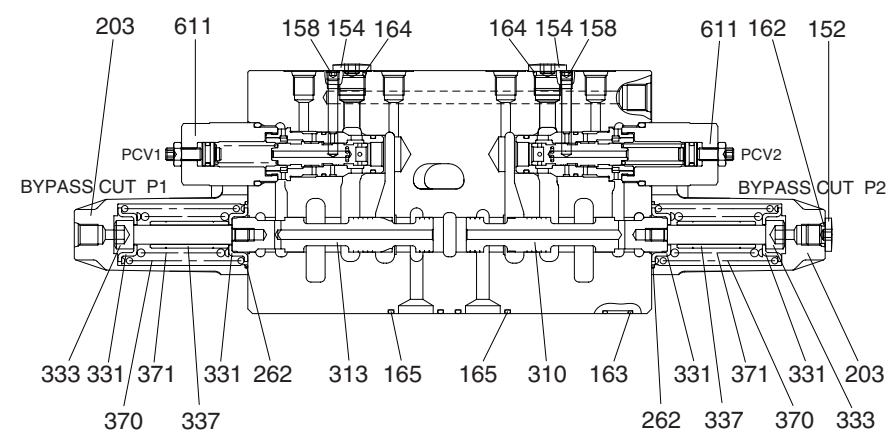

SECTION H-H

2. HYDRAULIC CIRCUIT

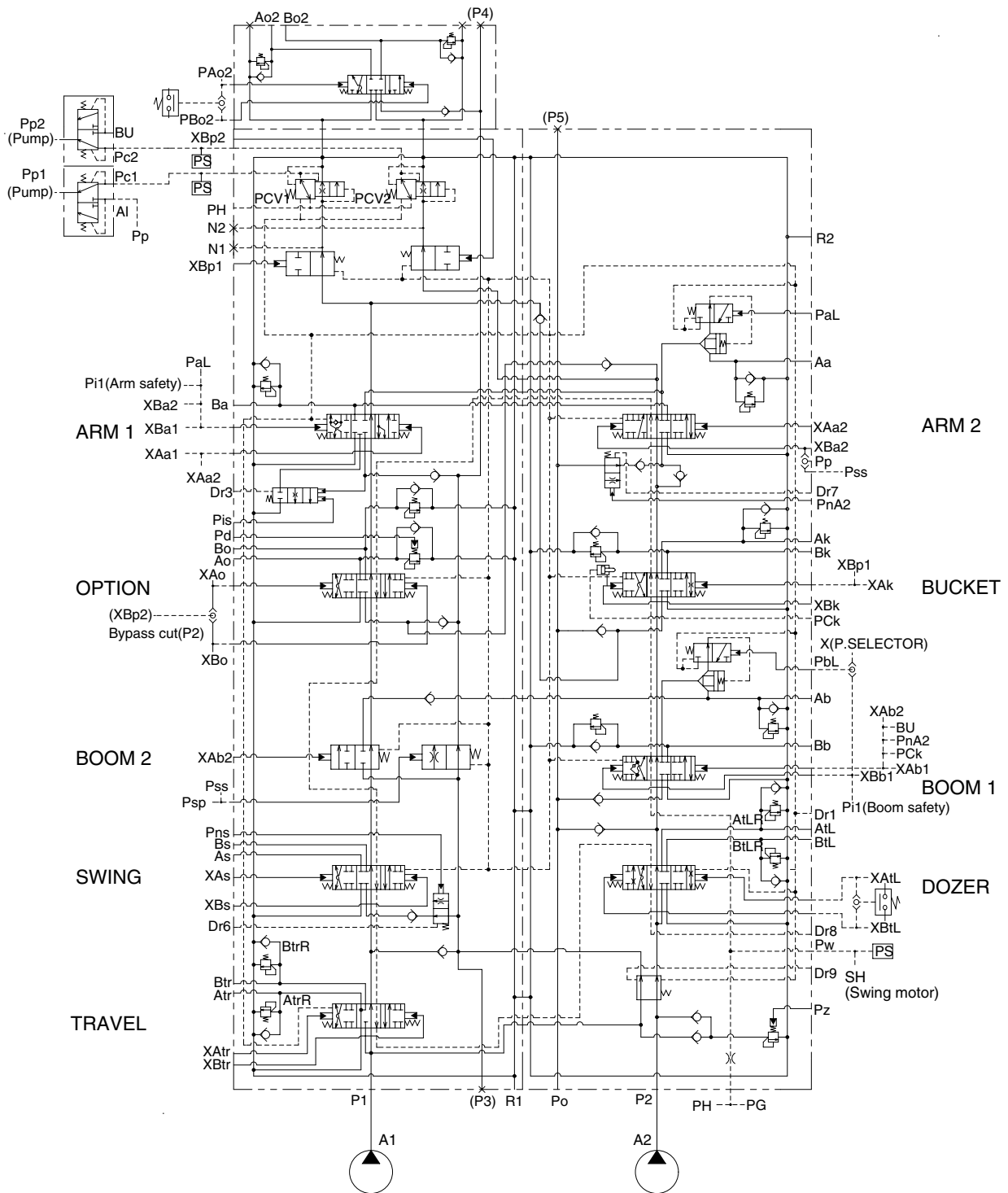

20W92MC04A

3. FUNCTION

1) CONTROL IN NEUTRAL POSITION

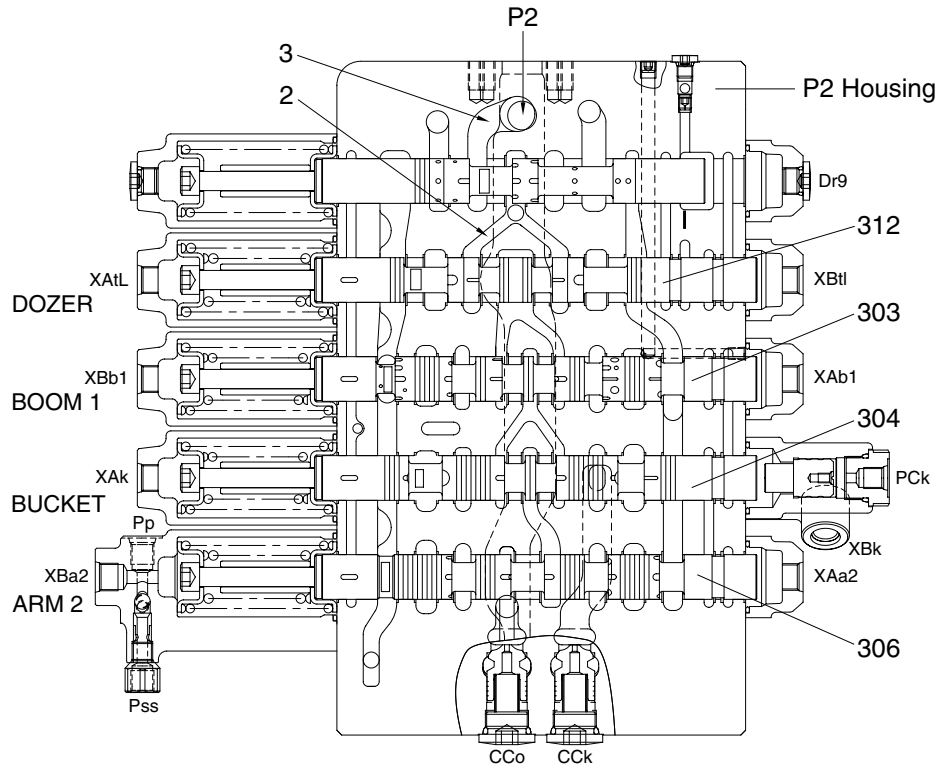

SPOOL SECTION(P2)

20W92MC05

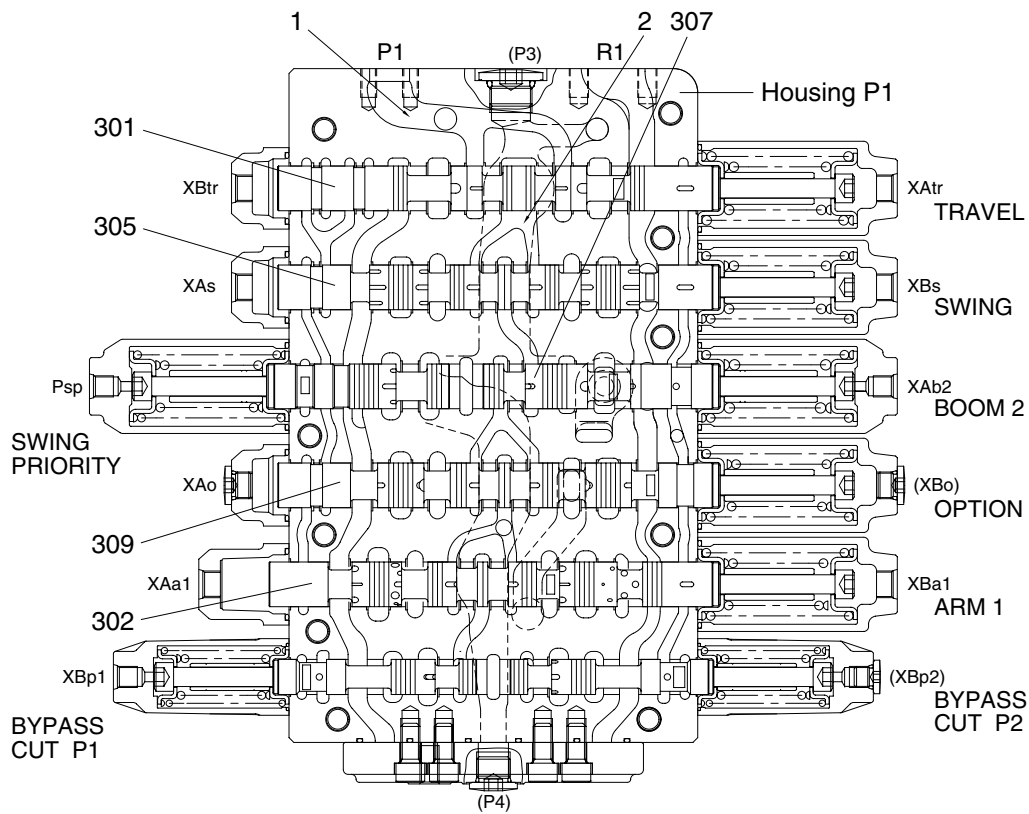

SPOOL SECTION(P1)

20W92MC06A

When all spools are in the neutral positions, the pressurized oil discharged from the hydraulic pump (A1) passes through Port P1, the main path (1), the bypass circuit (2) passing the spools for travel (301), swing (305), boom confluence (boom 2; 307), option (309) and arm 1 (302), and the arm 1 side posi-nega conversion valve (611), and returns to the hydraulic oil tank through the tank port (R1).

The positive control signal pressure (Pi1) of the arm 1 side posi-nega conversion valve (611) is led from Port Pc1 to the regulator (Pi1) on the hydraulic pump (A1) side, and controls the pump discharge flow rate to its minimum value.

The oil discharged from the hydraulic pump (A2) passes through Port P2, the main path (3), the bypass circuit (2) passing the spools for dozer (312), boom 1 (303), bucket (304) and arm 2 (306), and the boom1 side posi-nega conversion valve (611), and returns to the hydraulic oil tank through the tank port (R1).

The positive control signal pressure (Pi2) of the boom 1 side posi-nega conversion valve (611) is led from Port Pc2 to the regulator (Pi2) on the hydraulic pump (A2) side, and controls the pump discharge flow rate to its minimum value.

When any of nine main spools is changed over, the bypass circuit (2) is cut off and the hydraulic oil at Port N1 or N2 in the negative control circuit is shut off.

2) EACH SPOOL OPERATION

(1) Boom control

① Boom up operation

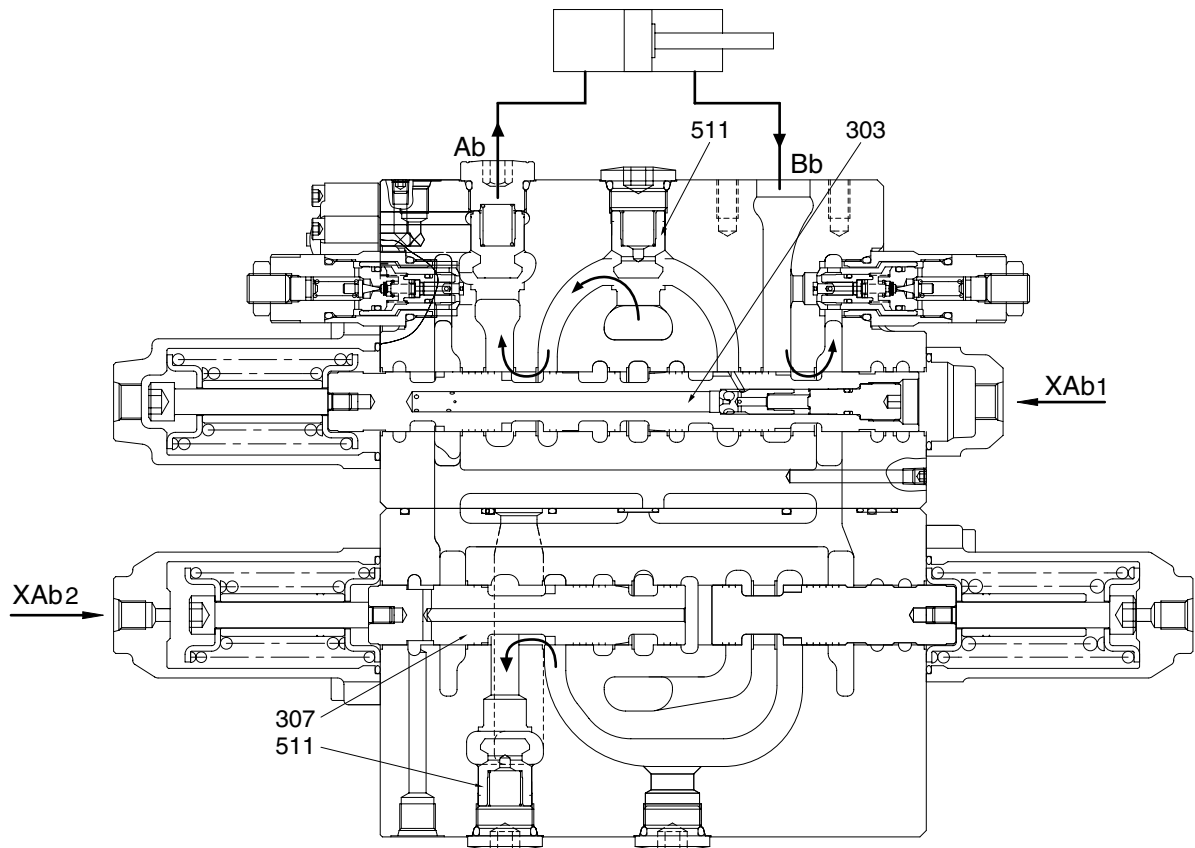

21092MC11

Pilot circuit

Since the boom 1 spool (303) transfers and shuts off the side-bypass path, the pressure at Port Px increases.

Main circuit

During the boom up operation, the pilot pressure enters through Port XAb1 and moves the boom 1 spool (303) in the left direction. The pressurized oil entering through Port P2 passes through the main path (3) and flows to the bypass circuit (2), but the bypass circuit (2) is shut off due to transfer of the boom 1 spool (303). Therefore, the pressurized oil flows into the parallel circuit, pushes open the check valve (511), and flows through the U-shaped path to the boom 1 spool (303). Then, it flows around the periphery of the boom 1 spool (303) to Port Ab, and is supplied to the boom cylinder head side.

At the same time, the pilot pressure enters also through Port XAb2 to transfer the boom 2 spool (307) in the right direction. Though the pressurized oil enters into Port P1, the bypass circuit (2) is shut off due to transfer of the boom 2 spool (307). Therefore, the hydraulic oil flows in the parallel circuit and flows through the U-shaped path to the boom 2 spool (307). Then, the hydraulic oil passes through the periphery of the boom 2 spool (307), pushes open the check valve (511), joins into Port Ab in the inside path, and is supplied to the boom cylinder head side. (Boom confluent flow)

On the other hand, the return oil from the boom cylinder rod side enters through Port Bb and returns to the hydraulic oil tank through the tank port (R1).

② Boom down operation

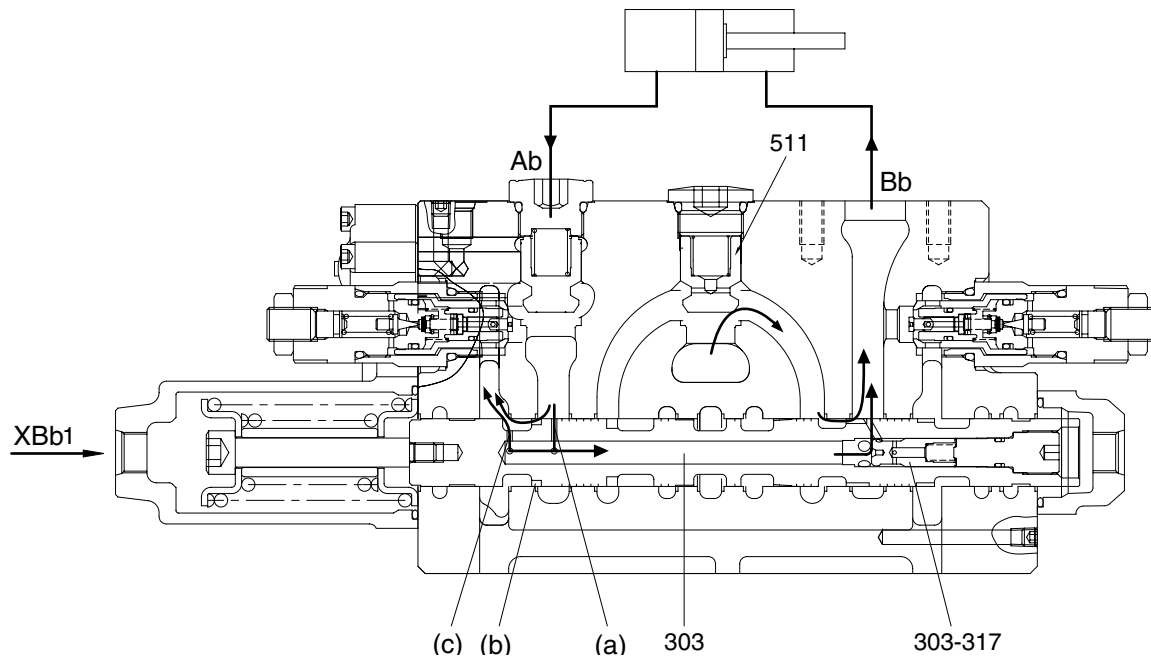

21092MC12

Pilot circuit

Since the boom 1 spool (303) transfers and shuts off the side-bypass path, the pressure at Port Px increases. Then, the pressure enters also through Port PbL and the release signal is sent to the lock valve (252).

Main circuit

During the boom down operation, the pilot pressure enters through Port XBb1 and transfers the boom 1 spool (303) in the right direction. The pressurized oil entering through Port P2 passes through the main path (3) and flows to the bypass circuit (2), but the bypass circuit (2) is shut off due to transfer of the boom 1 spool (303). Therefore, the pressurized oil flows into the parallel circuit, pushes open the check valve (511), and flows through the U-shaped path to the boom 1 spool (303). Then, it flows around the periphery of the boom 1 spool (303) to Port Bb and is supplied to the boom cylinder rod side.

On the other hand, the return oil from the boom cylinder head side passes to the holes (a) and the notches (b) of the boom 1 spool (303).

Since this return oil has a sufficient pressure caused by the weight of the boom, it passes through the path inside the spool, pushes the poppet (303-317) in the spool in the right direction, flows around the outside of the spool. Then, it is supplied again to the boom cylinder rod side as hydraulic oil to lower the boom. (Boom regeneration)

Besides, a part of the return oil from the boom cylinder flows from the hole (c) into the tank.

(2) Arm control

① Arm out operation

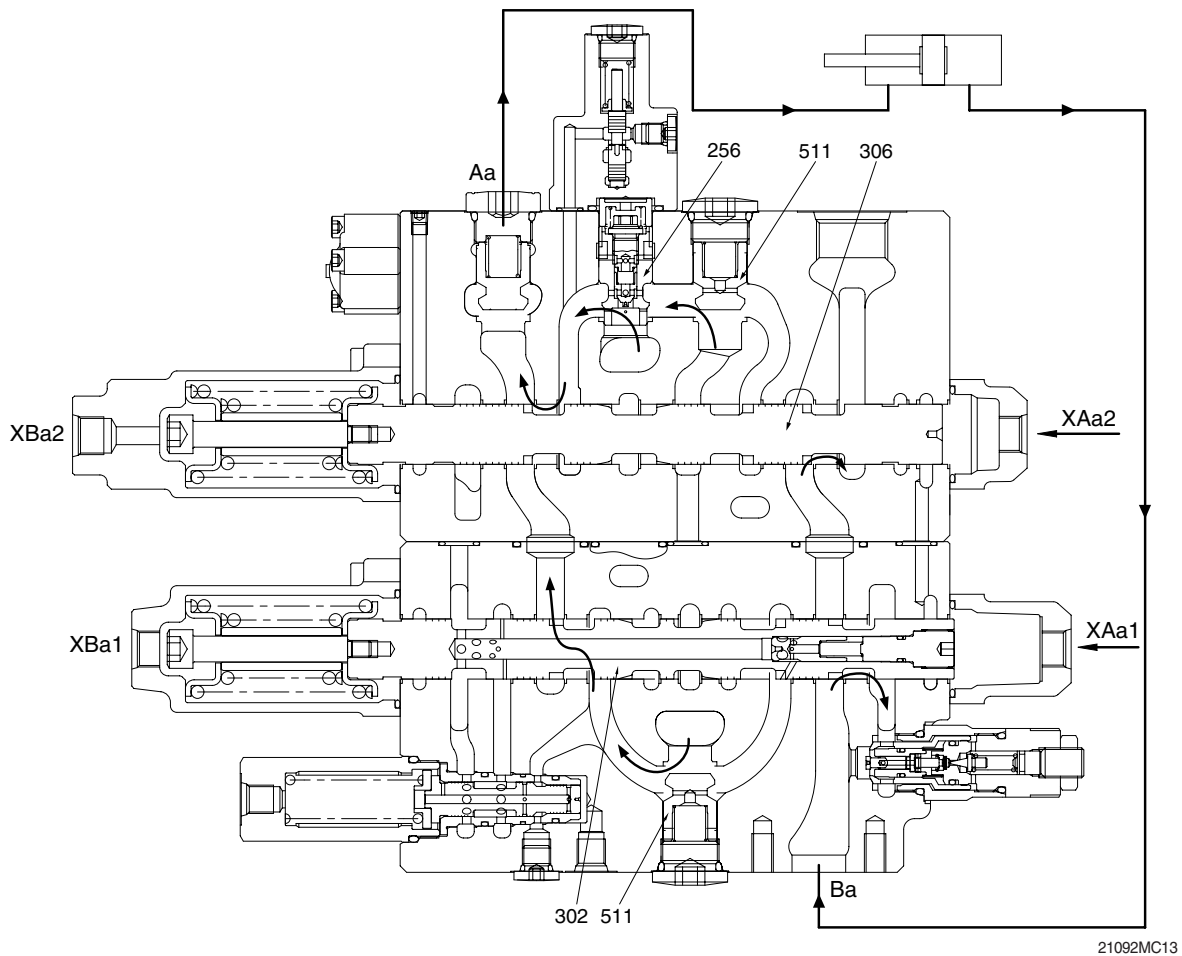

Pilot circuit

Since the arm 2 spool (306) transfers and shuts off the side-bypass path, the pressure at Port Px increases.

Main circuit

During the arm out operation, the pilot pressure enters through Ports XAa1 and XAa2. When the pressure enters through Port XAa1 and XAa2, the spools transfer in the left direction. The hydraulic oil entering through Port P1 passes through the main path (1) and flows to the bypass circuit (2), but the bypass circuit is shut off due to transfer of the arm 1 spool (302).

Therefore, the hydraulic oil from the parallel circuit pushes open the check valve (511) and flows through the U-shaped path to the arm 1 spool (302). Then, it flows around the periphery of the arm 1 spool (302) and the arm 2 spool (306) to Port Aa, and is supplied to the arm cylinder rod side.

On the other hand, the hydraulic oil entering through Port P2 passes in the main path (3), and flows into the bypass circuit (2), and the bypass circuit is shut off due to transfer of the arm 2 spool (306). The hydraulic oil from the parallel circuit pushes open the logic poppet (256) and the hydraulic oil from the bypass circuit (2) pushes open the check valve (511) and flows through the U-shaped path to the arm 2 spool (306). Then, it flows around the periphery of the arm 2 spool (306) in the inside path and joins into Port Aa.

Besides, the return oil from the arm cylinder head side passes through Port Ba, flows into tank line in arm 1 side and in arm 2 side, and returns to the hydraulic oil tank through the tank port (R1).

- ② Arm in operation
 - During light load only

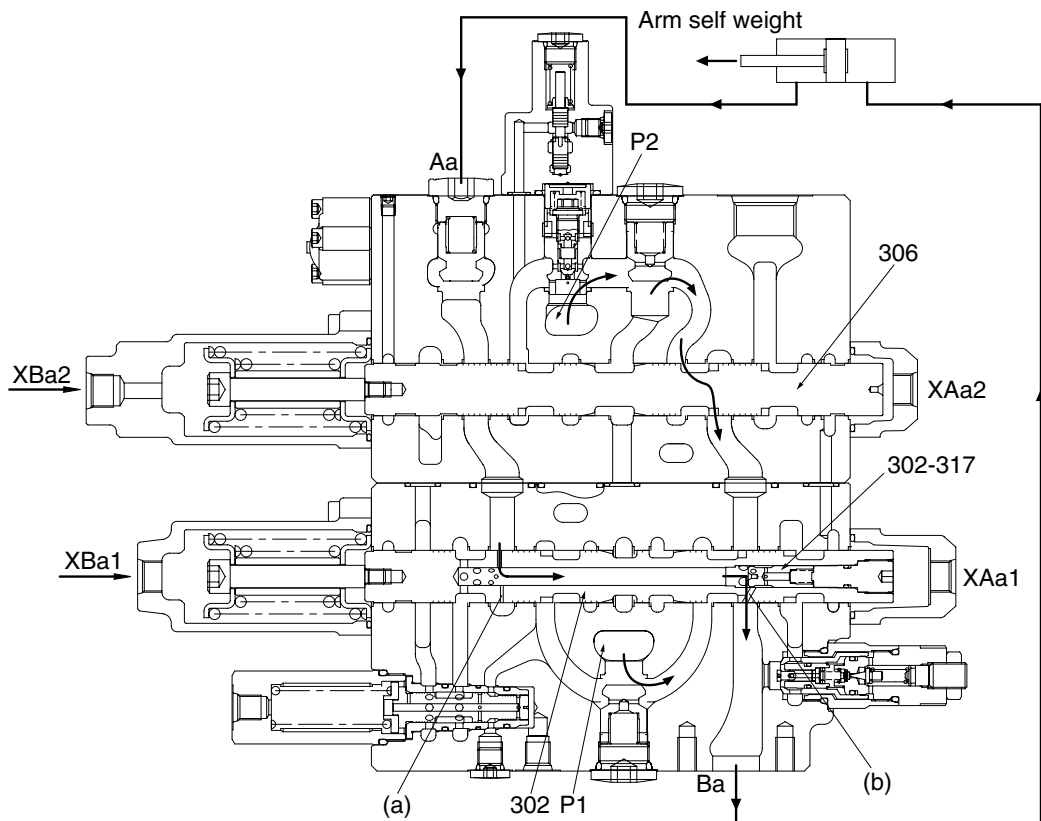

21092MC14

Pilot circuit

Since the arm 2 spool (306) transfers and shuts off the side-bypass path, the pressure at Port Px increases. Then, the pressure enters also through Port PaL and the release signal is sent to the lock valve (252).

Main circuit

During the arm in operation, the pilot pressure enters through Ports XBa1 and XBa2. When the pressure enters through Port XBa1 and Port XBa2, the spools transfer in the right direction Fig. MC14. The hydraulic oil entering through Port P1 passes through the main path (1) and flows to the bypass circuit (2), but the bypass circuit is shut off due to transfer of the arm 1 spool (302). Therefore, the hydraulic oil from the parallel circuit pushes open the check valve (511) and flows through the U-shaped path to the arm 1 spool (302). Then, it flows around the periphery of the arm 1 spool (302) to Port Ba, and is supplied to the arm cylinder head side.

On the other hand, the hydraulic oil entering through Port P2 passes in the main path (3), and flows into the bypass circuit (2), and the bypass circuit is shut off due to transfer of the arm 2 spool (306). The hydraulic oil from the parallel circuit pushes open the logic poppet (256) and the hydraulic oil from the bypass circuit (2) pushes open the check valve (511) and flows through the U-shaped path to the arm 2 spool (306). Then, it flows around the periphery of the arm 2 spool (306) and the arm 1 spool (302) in the inside path and joins into Port Ba.

Besides, the return oil from the arm cylinder rod side is pressurized by self-weight of the arms and so on, and returns to Port Aa. The pressurized oil returning to Port Aa enters into the spool through the periphery hole (a) of the arm 1 spool (302). During a light load only, it pushes open the check valve (302-317) and joins into Port Ba from the spool hole (b). The rest of oil returns to the hydraulic oil tank through the tank port (R1). This is called the arm regeneration function.

- The pressure in the arm cylinder head side increases

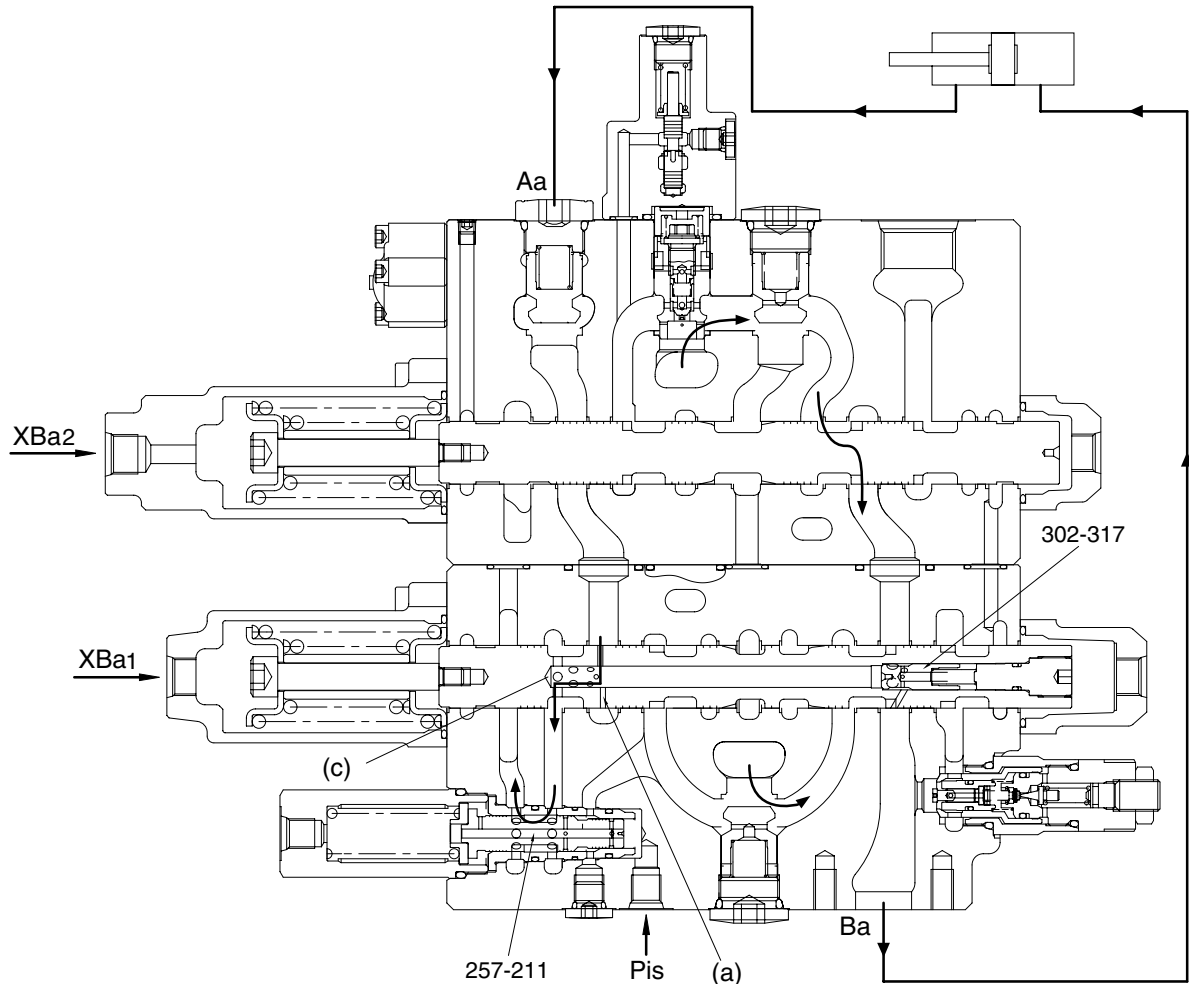

21092MC15

When the pressure in the arm cylinder head side and the U-shaped path increases, the arm regeneration cut spool (257-211) is transferred in the left direction, and at the same time the check valve (302-317) is closed by its backpressure. This shuts off the arm regeneration function, and the return oil from the arm cylinder rod side enters from Port Aa through the periphery hole (a) of the arm 1 spool (302) into the spool, flows to the arm regeneration cut valve (257) through the periphery hole (c) of the arm 1 spool (302), and returns through the tank port (R1) to the hydraulic oil tank.

When the Pilot Port Pis of the arm regeneration cut spool (257-211) is pressurized, a part of the return oil from the arm cylinder rod side flows to the arm regeneration cut valve (257) and returns through the tank port (R1) to the hydraulic oil tank. (Variable arm regeneration)

③ Arm 2 logic control valve operation

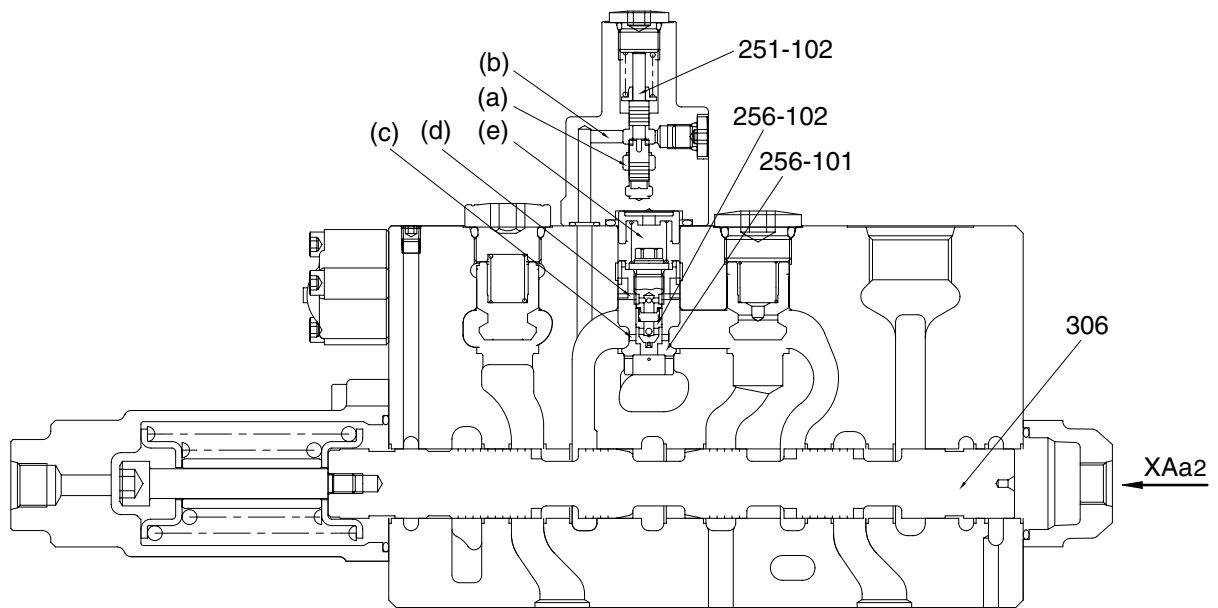

21092MC16

During both the arm in operation and the boom up operation, the pilot pressure enters through Ports XBa1, XBa2, XAb1, XAb2, PaL and PnA2. The pressure PnA2 transfers the spool (251-102) in the arm 2 logic control valve to the top direction, and the path from (a) to (b) is closed. Hereby, the pressurized oil pushes open the poppet (256-102), passes in the path (c) and (d), enters into the chamber (e), and the poppet (256-101) is pushed to the casing seat. Therefore, the most of pressurized oil entering through Port P2 flows to the boom 1 spool (303) than the arm 2 spool (306) to make the boom hoisting operation most preferential.

On the other hand, in the independent arm in operation, the pilot pressure does not enter through Ports PnA2, and the path from (a) to (b) is not closed, and the hydraulic oil of the chamber (e) flows to the path (a) and (b). The pressurized oil entering through Port P2 pushes open the poppet (256-101) and flows to the arm 2 spool (306).

(3) Bucket control

① Bucket in operation

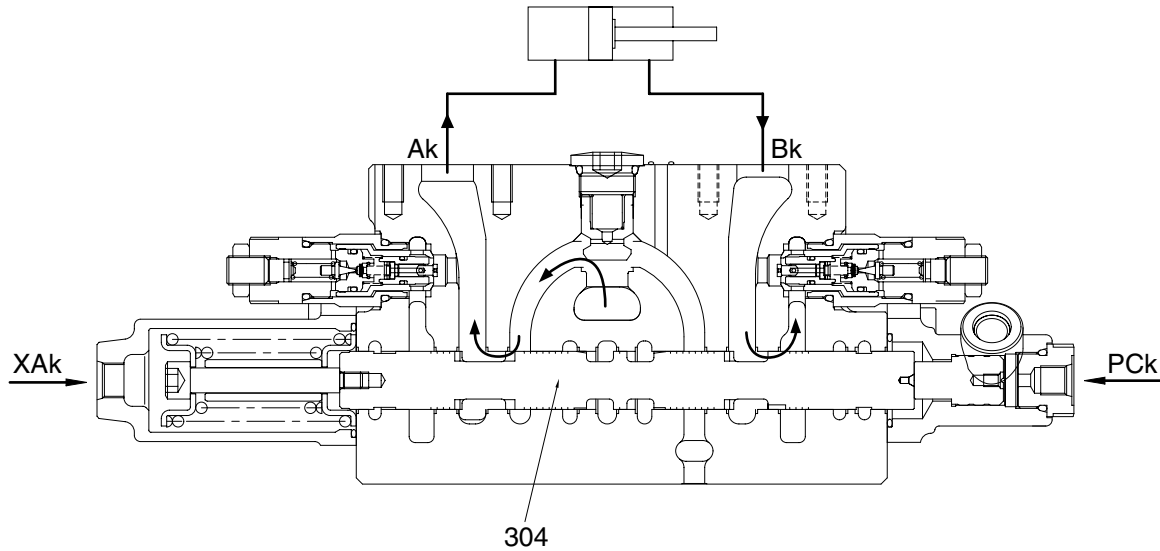

21092MC17

Pilot circuit

Since the bucket spool (304) transfers and shuts off the side-bypass path, the pressure at Port Px increases. Then, the pressure enters also through Port XBp1.

Main circuit

During the bucket in operation, the pilot pressure enters through Port XAk and transfers the bucket spool (304) in the right direction. The pressurized oil entering through Port P2 passes through the main path (3) and flows through the bypass circuit (2), but the bypass circuit (2) is shut off due to transfer of the bucket spool (304). Therefore, the pressurized oil flows into the parallel circuit, pushes open the check valve (511), and flows through the U-shaped path to the bucket spool (304). Then, it flows through the periphery of the spool to Port Ak and is supplied to the bucket cylinder head side.

On the other hand, the return oil from the bucket cylinder rod side enters through Port Bk, passes around the periphery of the spool, and returns to the hydraulic oil tank through the tank port (R1).

During both the boom up operation and bucket in operation, the pilot pressure enters through Port PCk and the bucket spool transfers in the half stroke not full stroke. Therefore, the most of pressurized oil entering through Port P2 flows to the boom 1 spool (303) than the bucket spool (304) to make the boom up operation most preferential.

② Bucket out operation

Pilot circuit

Since the bucket spool (304) transfers and shuts off the side-bypass path, the pressure at Port Px increases.

Main circuit

During the bucket out operation, the pilot pressure enters through Port XBk and transfers the bucket spool (304) in the left direction. The pressurized oil entering through Port P2 passes through the main path (3) and flows through the bypass circuit (2), but the bypass circuit (2) is shut off due to transfer of the bucket spool (304). Therefore, the pressurized oil flows into the parallel circuit, pushes open the check valve (511), and flows through the U-shaped path to the bucket spool (304). Then, it flows through the periphery of the spool to Port Bk and is supplied to the bucket cylinder rod side.

On the other hand, the return oil from the bucket cylinder head side enters through Port Ak, passes around the periphery of the spool, and returns to the hydraulic oil tank through the tank port (R1).

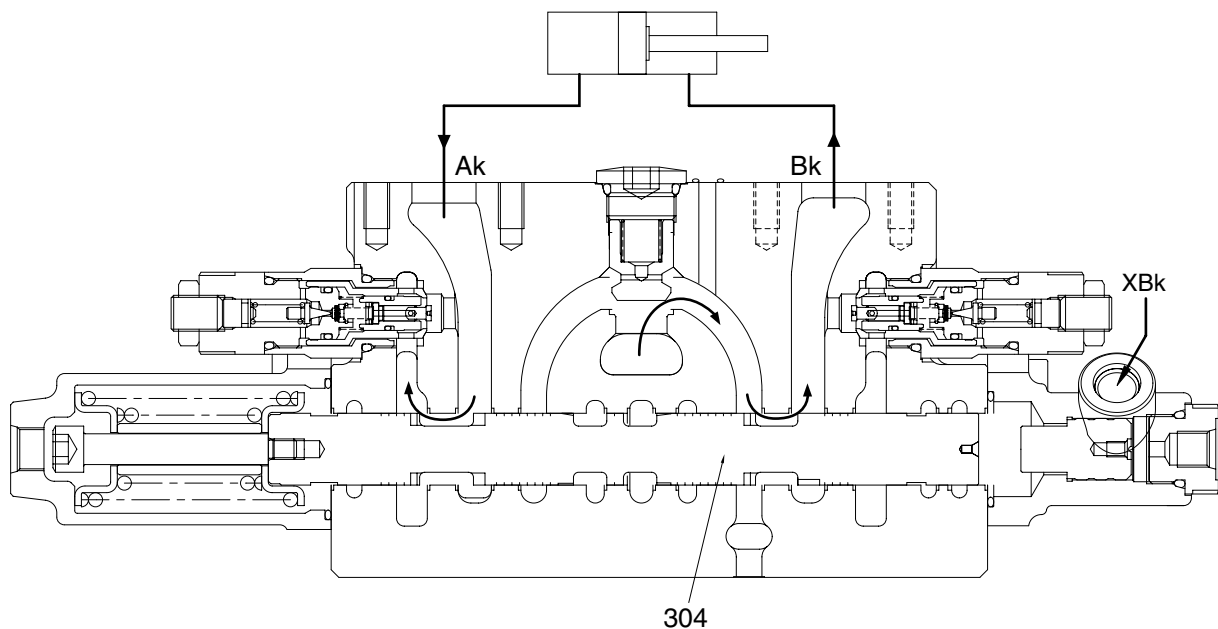

21092MC18A

③ Bucket in confluence

During the bucket in operation, the pilot pressure enters also through Port XBp1 and transfers the bypass-cut spool (313). The pressurized oil entering through Port P1 passes through the main path (1) and flows through the bypass circuit (2), but the bypass circuit (2) is shut off due to transfer of the bypass-cut spool (313). Therefore, the pressurized oil pushes open the check valve CCK (514), and flows through inside path and the U-shaped path to the bucket spool (304).

(4) Swing control

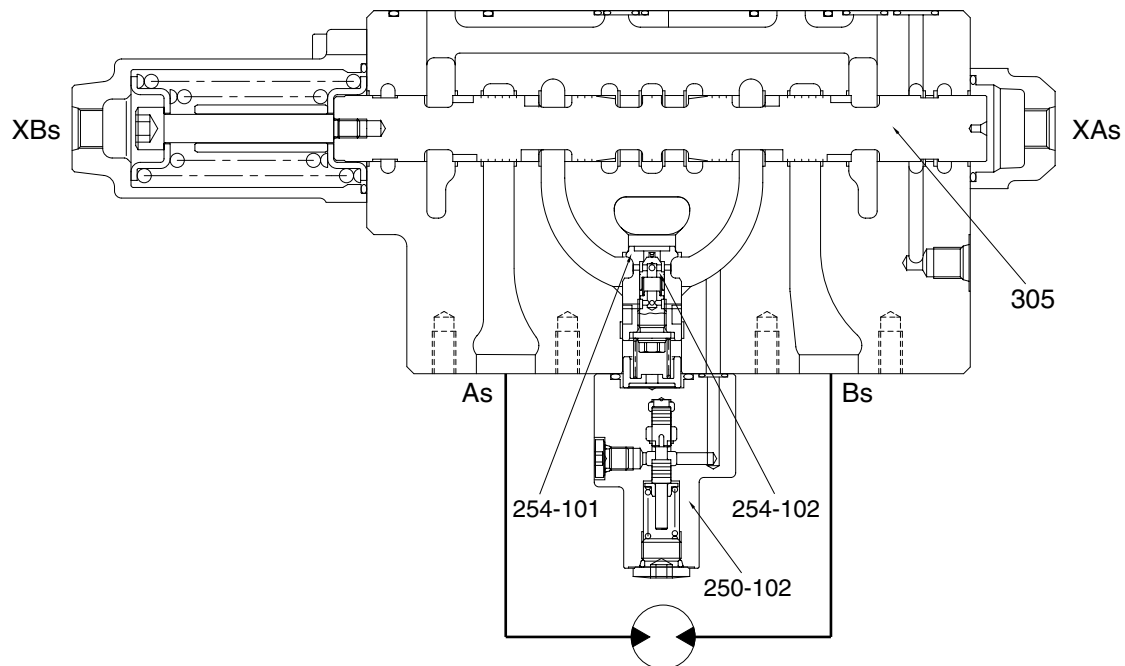

21092MC19

① Swing operation

Pilot circuit

Since the swing spool (305) transfers and shuts off the side-bypass path, the pressure at Port Px increases.

Main circuit

During the swing operation, the pilot pressure enters through Port XAs (or XBs) and transfers the swing spool (305). The pressurized oil entering through Port P1 passes through the main path (1) and flows through the bypass circuit (2), but the bypass circuit (2) is shut off due to transfer of the swing spool (305). Therefore, the pressurized oil flows into the parallel circuit, pushes open the check valve (511), and flows through the U-shaped path to the swing spool (305). Then, it flows through the periphery of the spool to Port As (or Bs) and is supplied to the swing motor.

On the other hand, the return oil from the swing motor enters Port Bs (or As) and returns to the hydraulic oil tank through the tank port (R1).

② Swing logic control valve operation

During both the swing operation and the boom up operation, the pilot pressure enters through Ports XBs (or XAs), XAb1, XAb2 and Pns. The pressure Pns transfers the spool (250-102) in swing logic control valve. Hereby, the pressurized oil pushes open the poppet (254-102), and the poppet (254-101) is pushed to the casing seat. Therefore, the most of pressurized oil entering through Port P1 flows to the boom 2 spool (307) than the swing spool (305) to make the boom up operation most preferential.

On the other hand, in the independent swing operation, the pilot pressure does not enter through Ports Pns. The pressurized oil entering through Port P1 pushes open the poppet (254-101) and flows to the swing spool (305).

③ Swing operation preference function

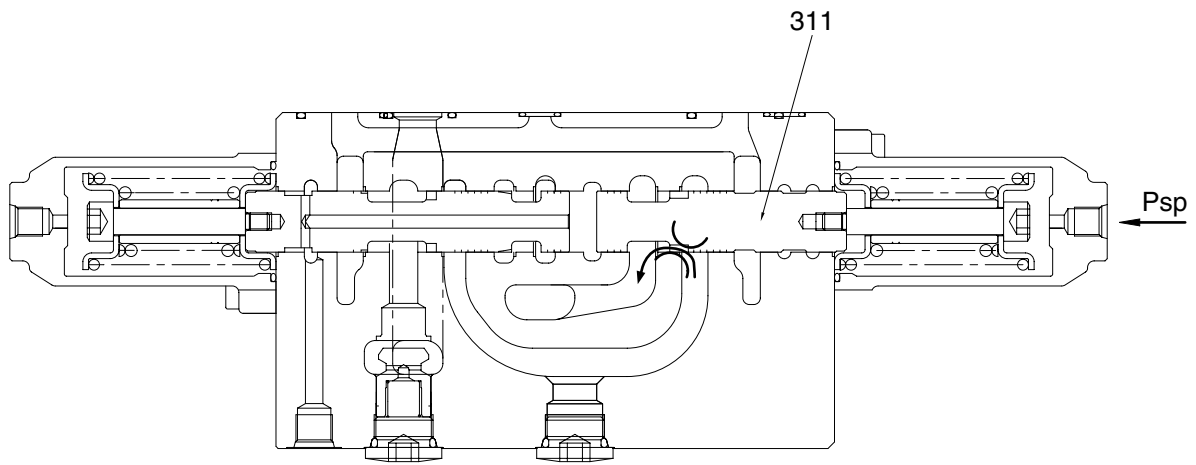

21092MC20

Pilot circuit

The pilot pressure enters through Port Psp to transfer the swing priority spool (311).

Main circuit

Due to transfer of the swing priority spool (311), the open area of the swing priority spool decreases, and the most of the pressurized oil entering through Port P1 flows to the swing side to make the swing operation most preferential.

(5) Travel control

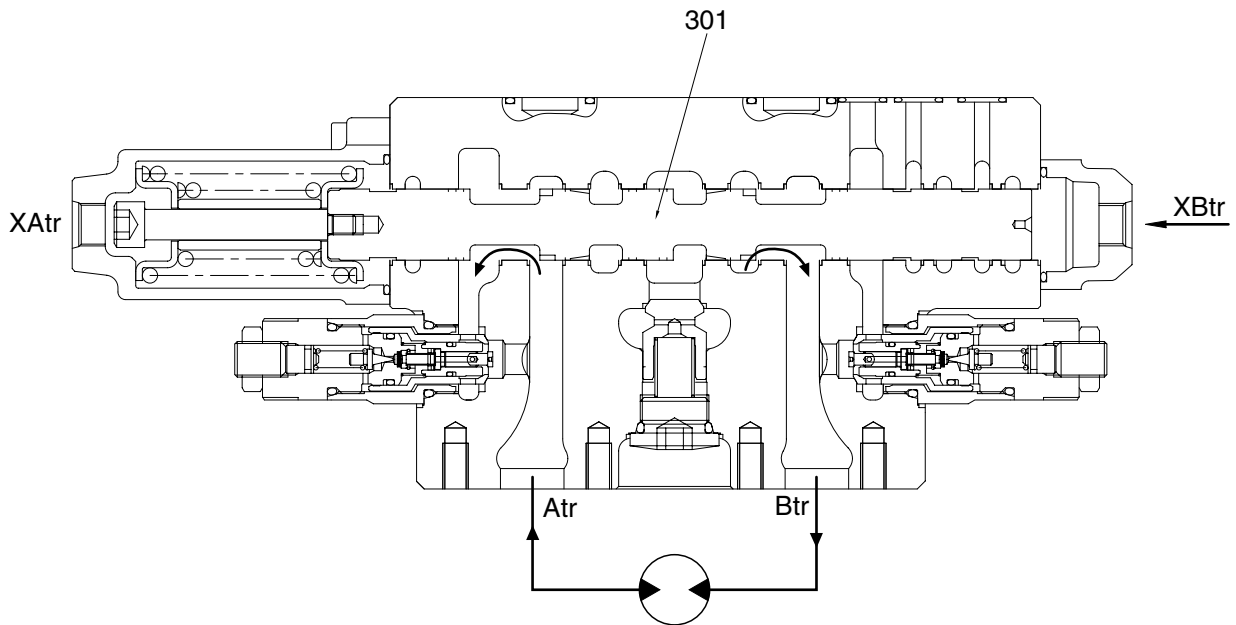

20W92MC07

Pilot circuit

Since the travel spool (301) transfers and shuts off the side-bypass path, the pressure at Port Pw increases.

Main circuit

When Pilot Port XBtr of the travel spool (301) is pressurized, the bypass circuit (2) in the arm 1 side is shut off and the working fluid discharged from the hydraulic pump (A1) through Port Btr and flows to the travel motor.

On the other hand, the return oil from the travel motor passes flows from Port Atr to the travel spool (301) and returns to the hydraulic oil tank through the tank port (R1).

In the case of the opposite operation (when the pilot pressure is applied to Ports XAtr of the control valve), the operation is similar.

(6) Dozer operation

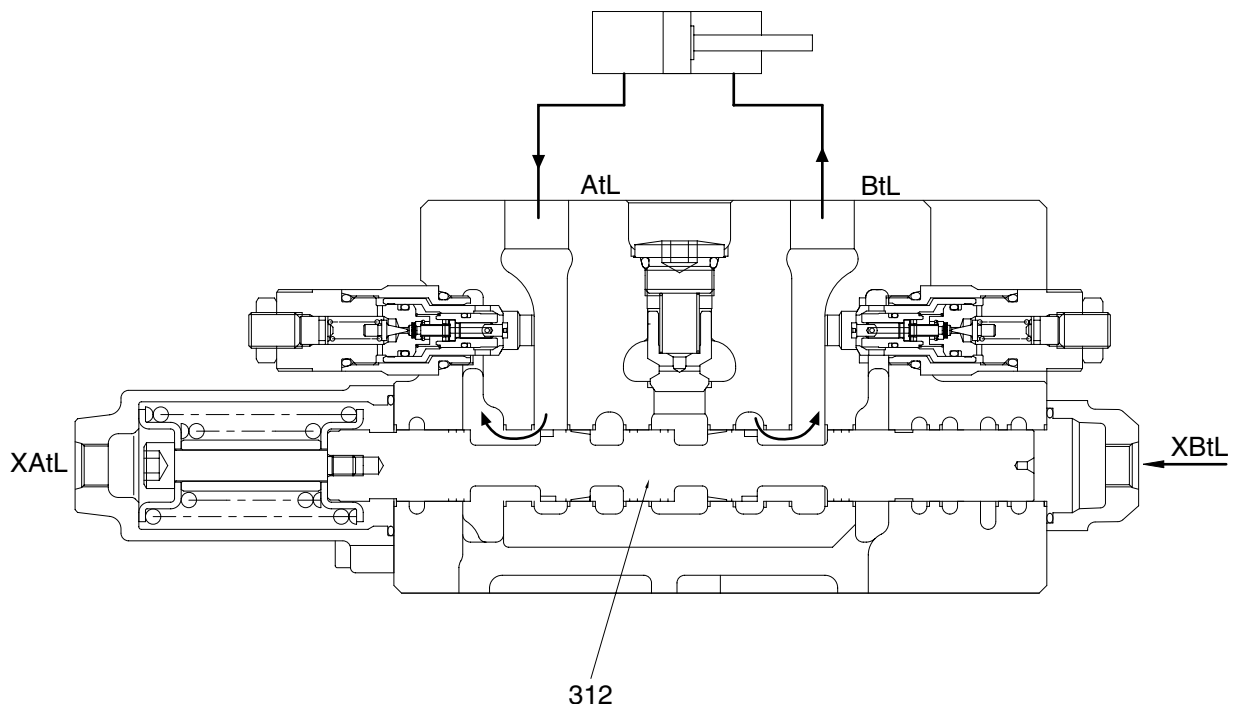

20W92MC08

Pilot circuit

Since the dozer spool (312) transfers and shuts off the side-bypass path, the pressure at Port Pw increases.

Main circuit

When Pilot Port XBtL of the dozer spool (312) is pressurized, the bypass circuit (2) in the boom 1 side is shut off and the working fluid discharged from the hydraulic pump (A2) through Port BtL and flows to the dozer cylinder rod side.

On the other hand, the return oil from the dozer cylinder rod side passes flows from Port AtL to the dozer spool (312) and returns to the hydraulic oil tank through the tank port (R1).

In the case of the opposite operation (when the pilot pressure is applied to Ports XAtL of the control valve), the operation is similar.

3) FUNCTION OF LOCK VALVE

The lock valve (252) is fitted between the arm cylinder rod side and the arm 2 spool (306). It decreases the leakage by the pressure of the cylinder.

Another lock valve (252) is similarly fitted between the boom cylinder head side and the boom 1 spool (303). It decreases the leakage by the pressure of the cylinder.

(1) Neutral positions of spools

The following is the case of the boom 1 spool (303). (The case of the arm 2 spool (306) is in the same way.)

During the boom 1 spool (303) is in the neutral position, the lock valve (252) is kept in the position shown in figure. The spool (252-511) in the lock valve is pushed to the seat of the sleeve (252-541) by the force of the spring (252-321).

In this position, the pressurized oil from the boom cylinder head side enters through the hole (a), the periphery of the spool (252-511) in the lock valve and the hole (b), and it pushes the poppet (513) to the casing seat, and the leakage is decreased.

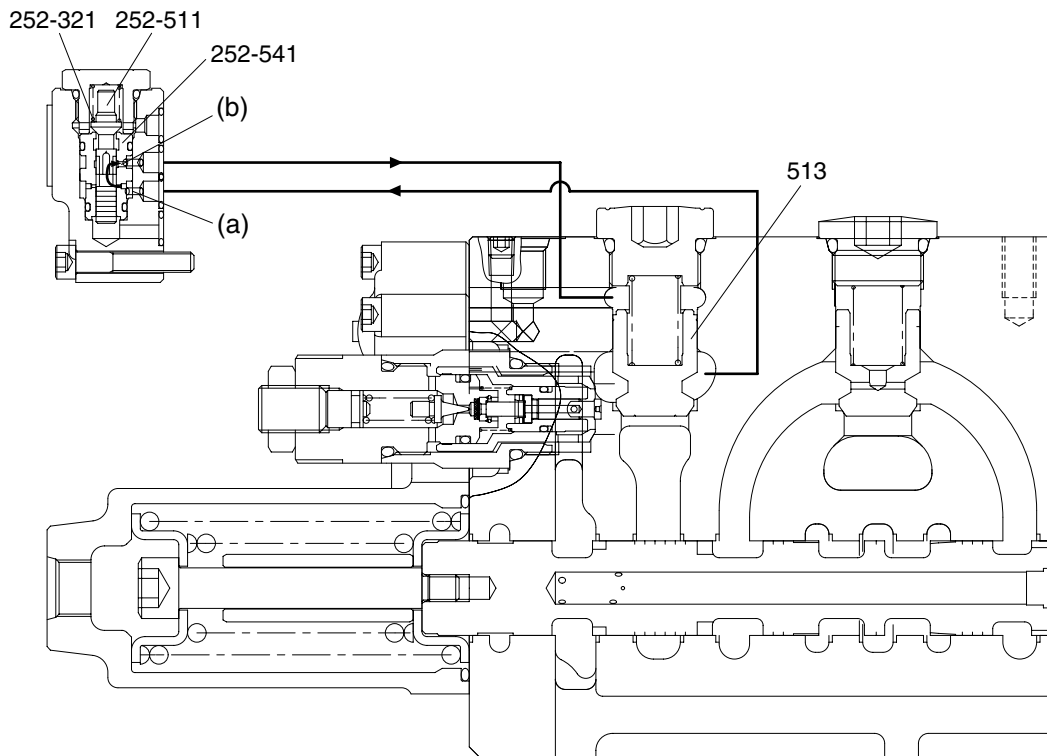

21092MC35

(2) Boom down operation

During the boom down operation, the pilot pressure enters through Port PbL and XBb1. The pilot pressure transfers the spool (252-511) in the lock valve assy in the top direction. By the transfer of the spool (252-511), firstly the hole (a) is blocked and the pressurized oil from the boom cylinder head side does not enter to the spring chamber (RH). Secondly, the oil in the spring chamber (RH) enters through the hole (b) and flows to drain circuit. Therefore, the poppet (513) is lifted by the pressure of the boom cylinder head side and the function of the lock valve (252) is released.

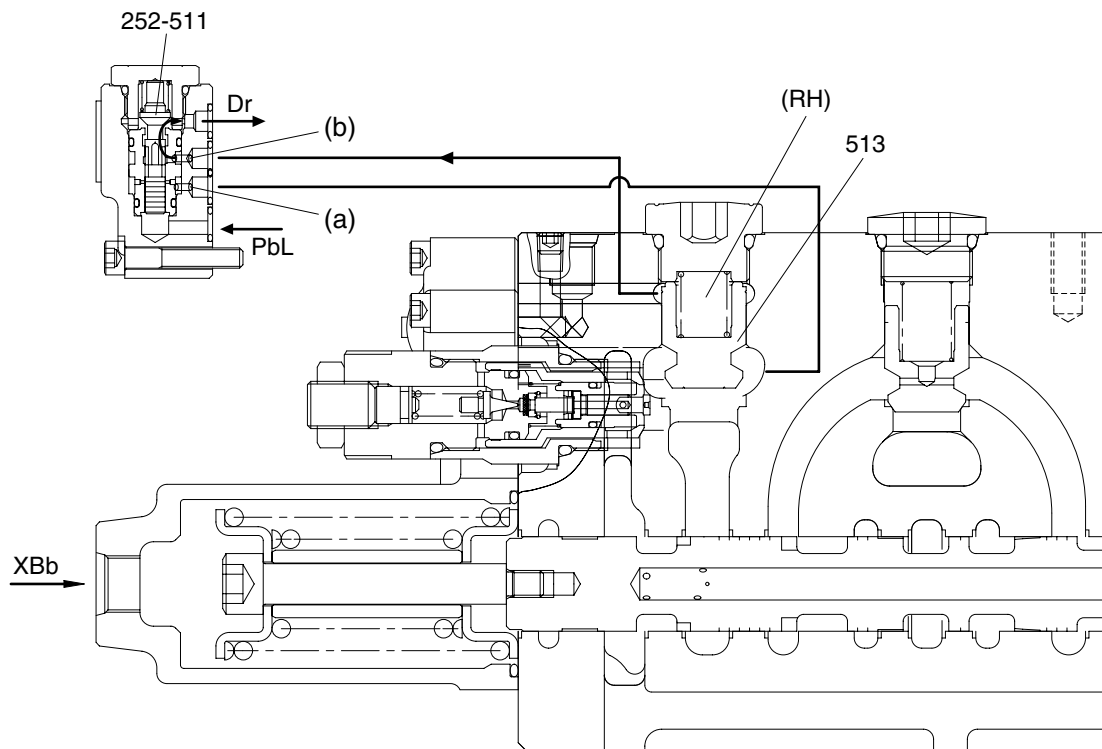

21092MC36

(3) Boom up operation

During the boom up operation, the pilot pressure enters through Port XAb1. The oil flowing from the boom 1 spool pushes open the poppet (513) and flows to Port Ab.

4) Posi-Nega Conversion Valve

The posi-nega conversion valve is installed between the downstream of the center bypass path and the low-pressure path, and functions as follows:

- (1) The delivery oil (flow rate Q) from the pump is led to the path P after passing the center by-pass path (2).

Then, it flows to the path R passing through the orifice A. On the other hand, the primary pressure oil from the port PH flows to the port Pc1 (or Pc2) through the periphery of the spool (511). On that occasion, the spool (511) remains to be pressed by the spring (621) if the pressure at the path P and the pressure at the port Pc1 (or Pc2) are below the preset pressure.

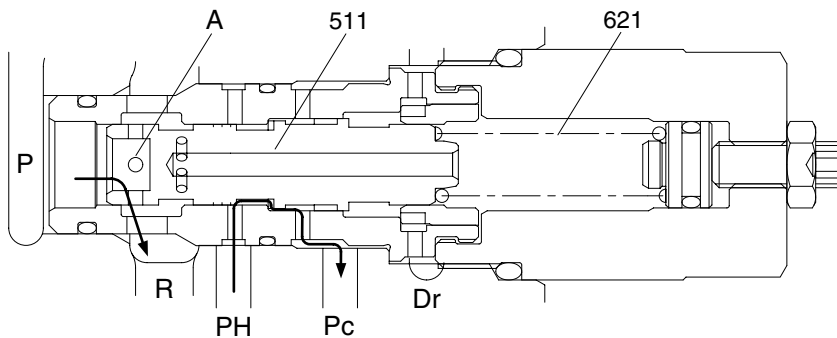

21092MC30

- (2) When the flow rate Q increases and the pressure at the path P increases, the spool (511) begins to move to the right, and so adjusts the Pc1 (or Pc2) pressure at the notches of the path B and C that the pressure at the path P and the Pc1 (or Pc2) pressure are balanced with the spring (621) at the set pressure. When the pressure at the path P rises, the Pc1 (or Pc2) pressure is lowered. The relationship between the flow rate Q of the hydraulic oil flowing from the path P to the path R and the pressure at the port Pc1 (or Pc2) is as shown in graph.

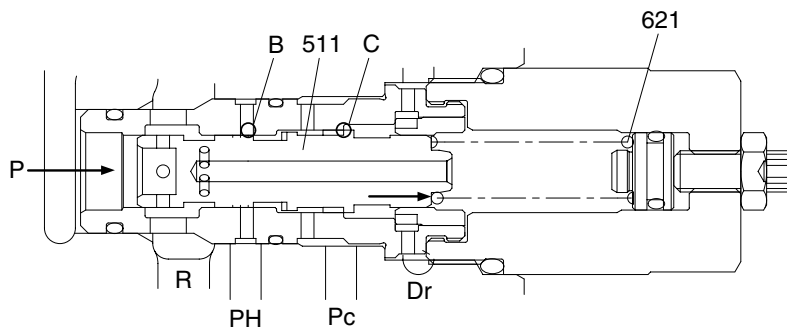

21092MC31

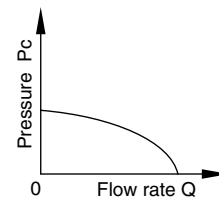

21092MC34

- (3) The pressure at Pc1 (or Pc2) is used for the control of pump discharge flow rate, and the pump discharge flow rate can be reduced by lowering the Pc1 (or Pc2) port pressure.

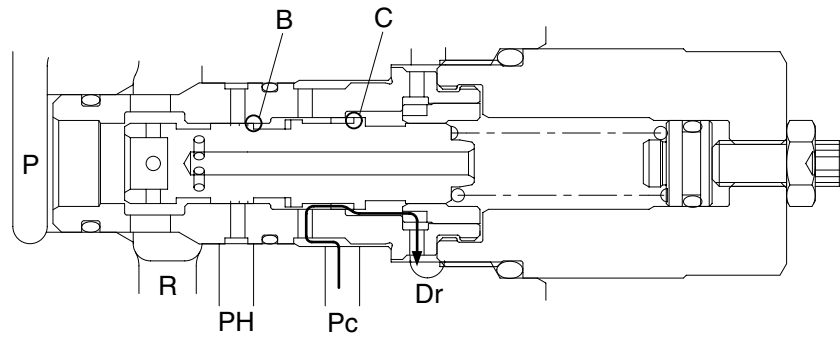

21092MC32

- (4) If the flow rate Q increases more than required, the spool strokes to largely open the P – R line, generating the relieving condition.

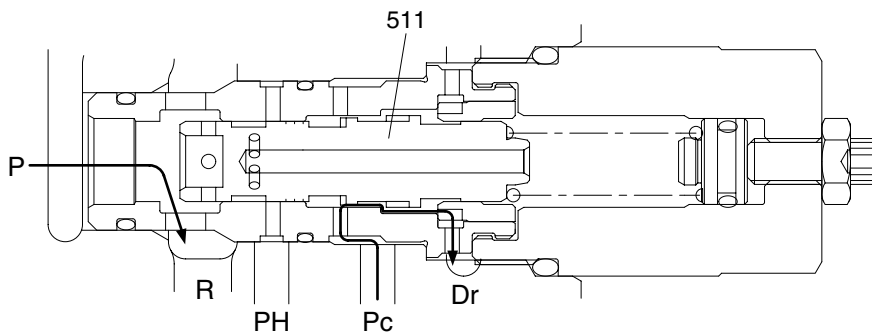

21092MC33

5) CIRCUIT PRESSURE PROTECTION

The control valve has two kinds of relief valve to limit the pressure in a circuit.

(1) Main relief valve

The main relief valve is fitted in the P2 housing and functions as follows.

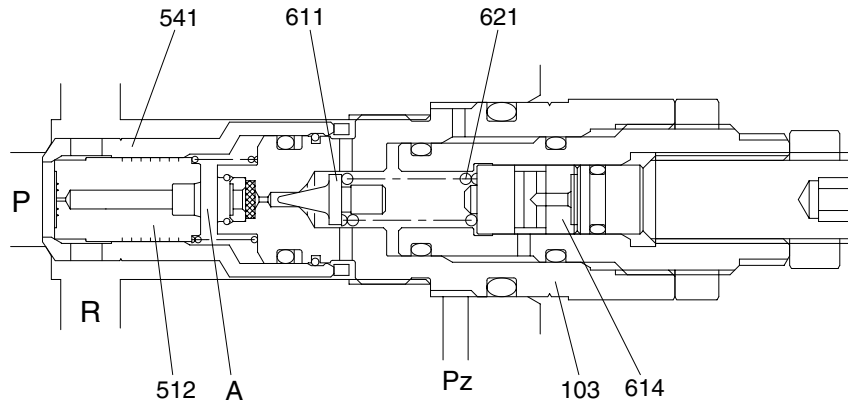

21092MC25

- ① The hydraulic oil is filled up in the inside space chamber (A) from the path (P) through a hole of the seat (541) and a restriction of the plunger (512), and seats the plunger (512) against the seat (541) securely.
- ② When the pressure in the path (R) becomes equal to the set load of the spring (621), the poppet (611) opens to make the hydraulic oil flow through a hole of the plug (103), around the poppet (611) and into the low pressure path (R).
- ③ Opening of the poppet (611) causes the pressure in the chamber (A) to fall and the plunger (512) to open. As the result the pressurized oil in the path (R) runs into the low pressure path (R) directly.
- ④ When the pressurized oil higher than pressure 30 kgf/cm² enters through the port Pz, it pushes the piston (614) to change the relief set pressure of the spring (621) to the high pressure.

(2) Port relief valve

The port relief valve is fitted between the cylinder port and low-pressure path. In addition to the relief valve, this serves also as an anti-cavitation check valve, and functions as follows:

① Function as relief valve

- a. The pressurized oil passes through Hole A of the piston (301), is filled up in Chamber B of the inside space, and seat the plunger (511) against the seat (541) securely.

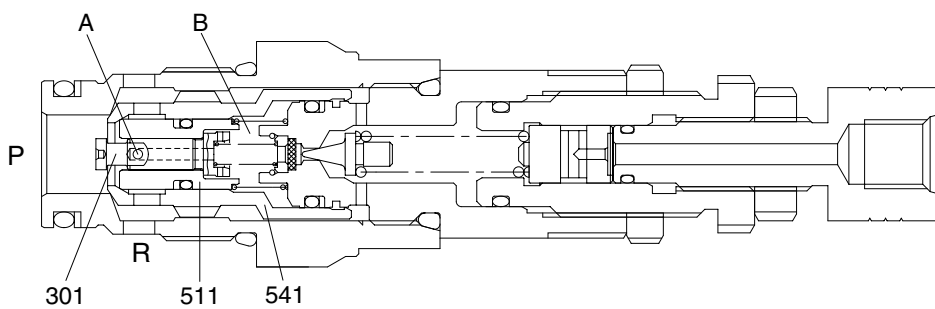
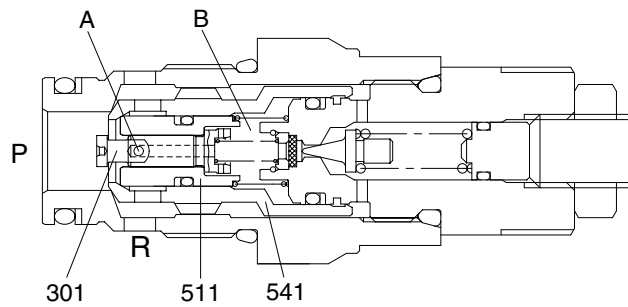
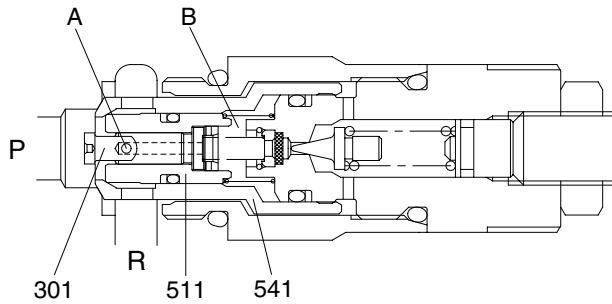

21092MC26

- b. When the pressure in the path (P) becomes equal to the set pressure of the spring (621 or 622), the pressurized oil pushes open the poppet (611), flows around it, and flows to the low pressure path (R) through hole C.

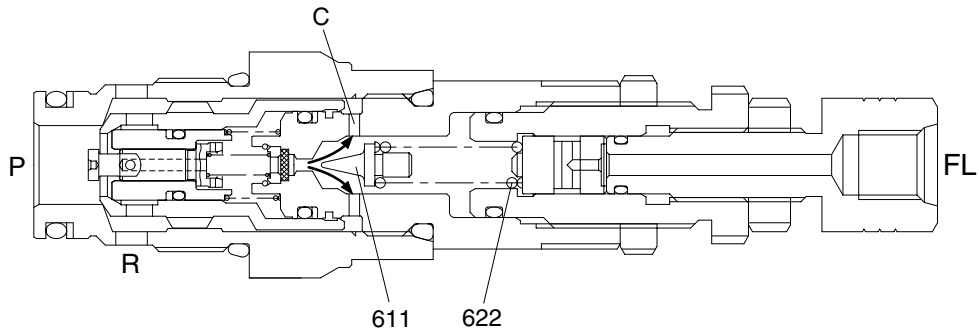
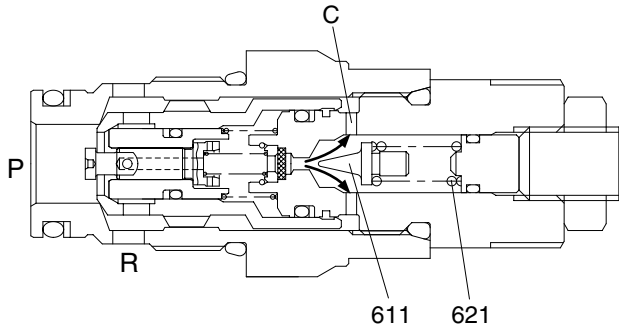
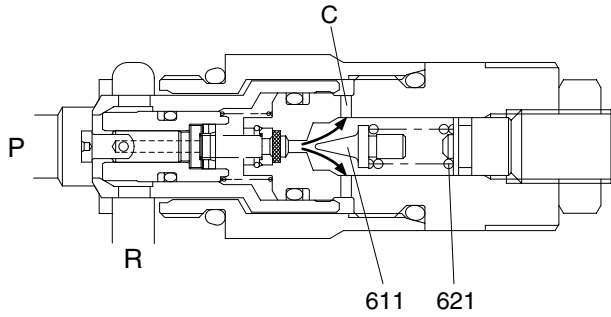

21092MC27

- c. Opening of the poppet (611) causes the pressure in Chamber B to fall and the plunger (511) to open. As the result the pressurized oil in the path (P) runs into the low pressure path (R) directly.

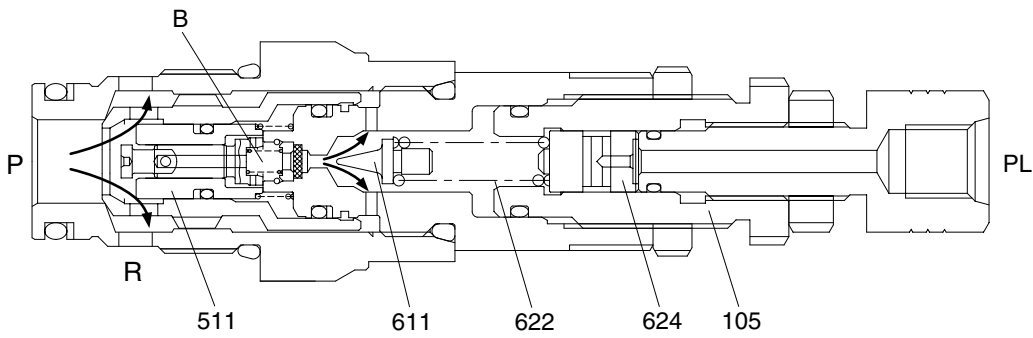
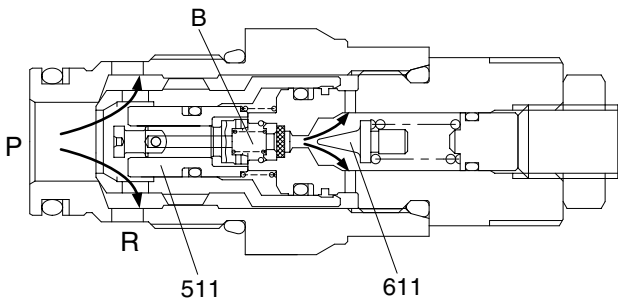
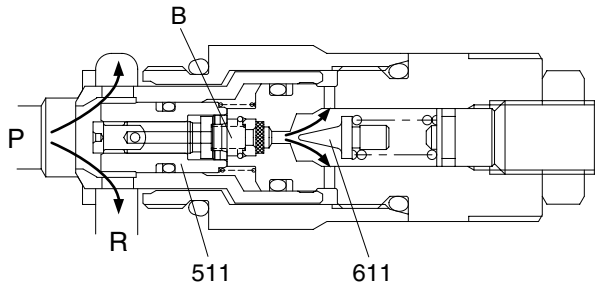

21092MC28

- d. When the pressurized oil higher than pressure 25 kgf/cm² enters through the port PL, it pushes the piston (624) to change the relief set pressure of the spring (622) to the high pressure.

② **Function as Anti-Cavitation Check Valve**

When any negative pressure exists in the path (P), the oil is supplied through the path (R). When the pressure at (R) becomes higher than that in the path (P), the seat (541) moves in the right direction. Then, sufficient oil passes around the seat (541) from the path (R) to the path (P) and prevents cavitation.

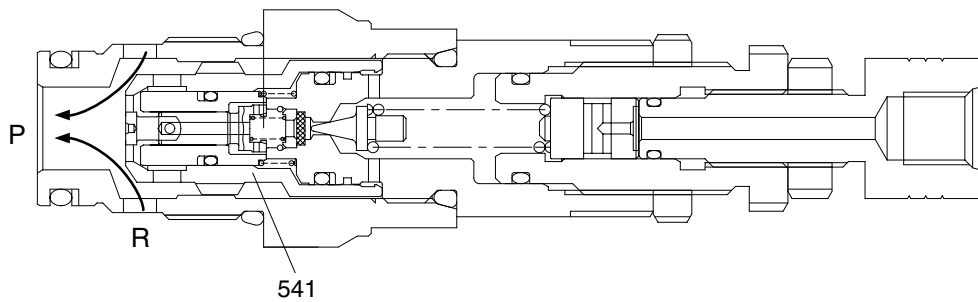
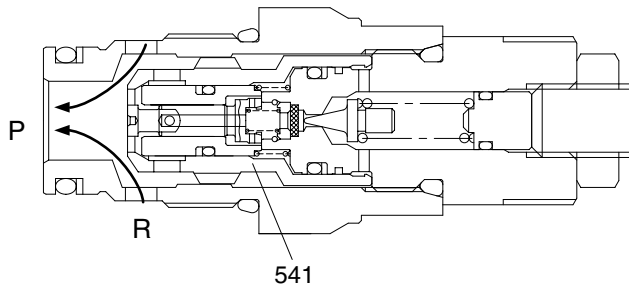
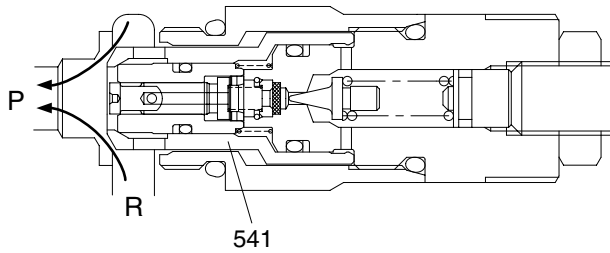

21092MC29