

## GROUP 3 SWING DEVICE

### 1. STRUCTURE

Swing device consists swing motor, swing reduction gear.

Swing motor include mechanical parking valve, relief valve, make up valve and time delay valve.

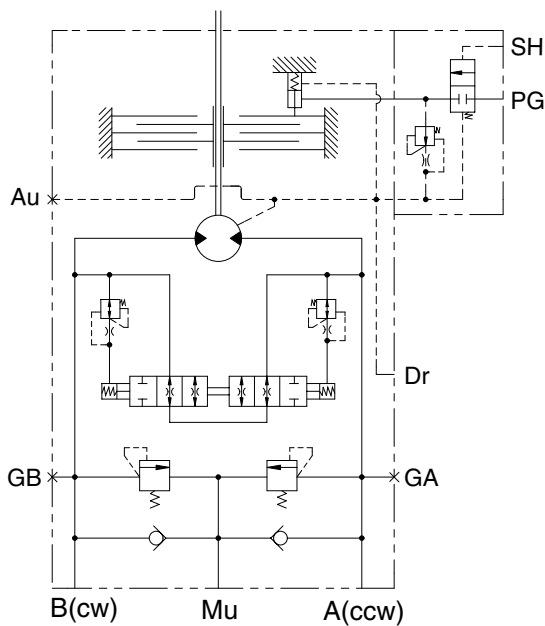
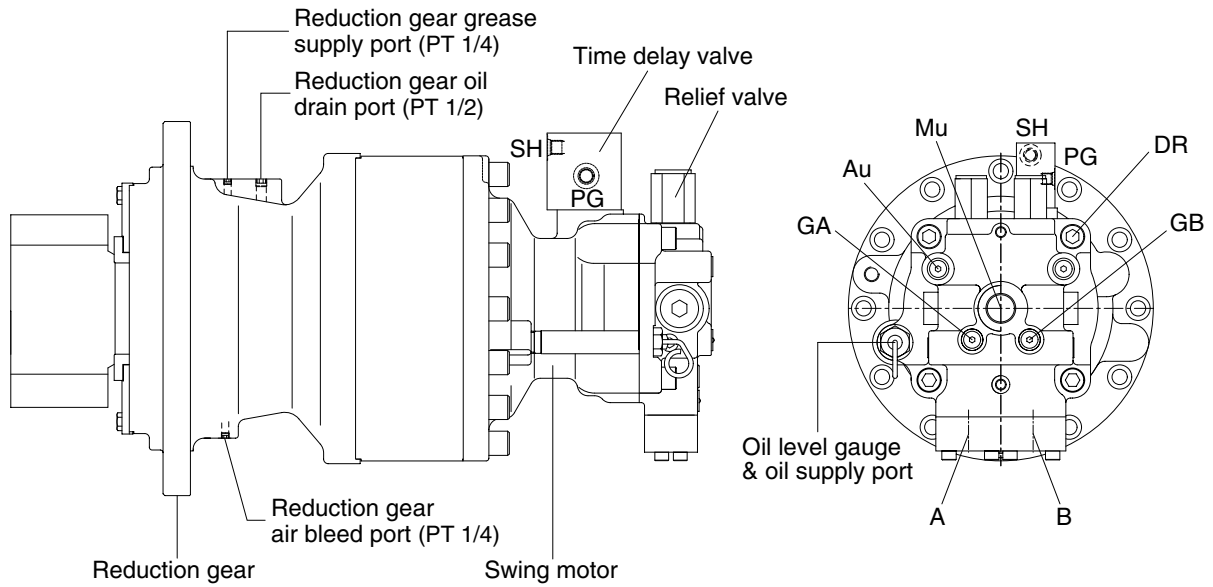

Hydraulic circuit

Port	Port name	Port size
A	Main port	ø 20
B	Main port	ø 20
Dr	Drain port	PF 1/2
Mu	Make up port	PF 1
PG	Brake release port	PF 1/4
SH	Stand by port	PF 1/4
GA, GB	Gauge port	PF 1/4
Au	Air vent port	PF 1/4

21092SM01

# 1) SWING MOTOR

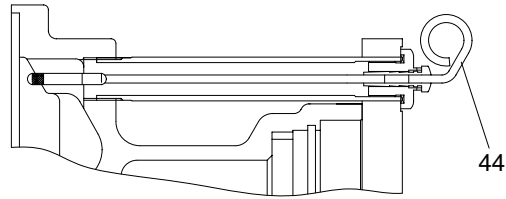

**DETAIL K**

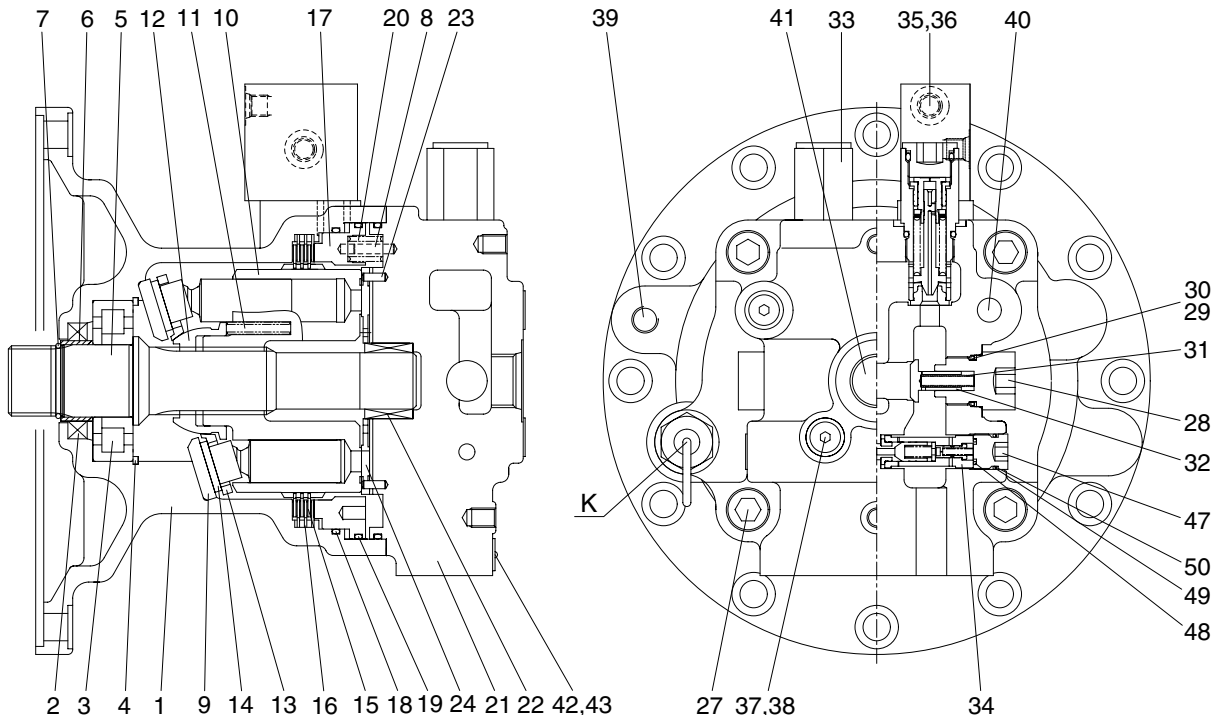

20W92SM02

- |                   |                         |                     |
|-------------------|-------------------------|---------------------|
| 1 Body            | 17 Brake piston         | 35 Time delay valve |
| 2 Oil seal        | 18 O-ring               | 36 Wrench bolt      |
| 3 Roller bearing  | 19 O-ring               | 37 Plug             |
| 4 Snap ring       | 20 Spring               | 38 O-ring           |
| 5 Shaft           | 21 Rear cover           | 39 Plug             |
| 6 Bushing         | 22 Needle bearing       | 40 Plug             |
| 7 Stop ring       | 23 Pin                  | 41 Plug             |
| 8 Pin             | 24 Valve plate          | 42 Name plate       |
| 9 Shoe plate      | 27 Wrench bolt          | 43 Rivet            |
| 10 Cylinder block | 28 Plug                 | 44 Level gauge      |
| 11 Spring         | 29 Back up ring         | 47 Plug             |
| 12 Ball guide     | 30 O-ring               | 48 O-ring           |
| 13 Set plate      | 31 Spring               | 49 O-ring           |
| 14 Piston assy    | 32 Check                | 50 Back up ring     |
| 15 Friction plate | 33 Relief valve         |                     |
| 16 Plate          | 34 Anti-inversion valve |                     |

## 2) REDUCTION GEAR

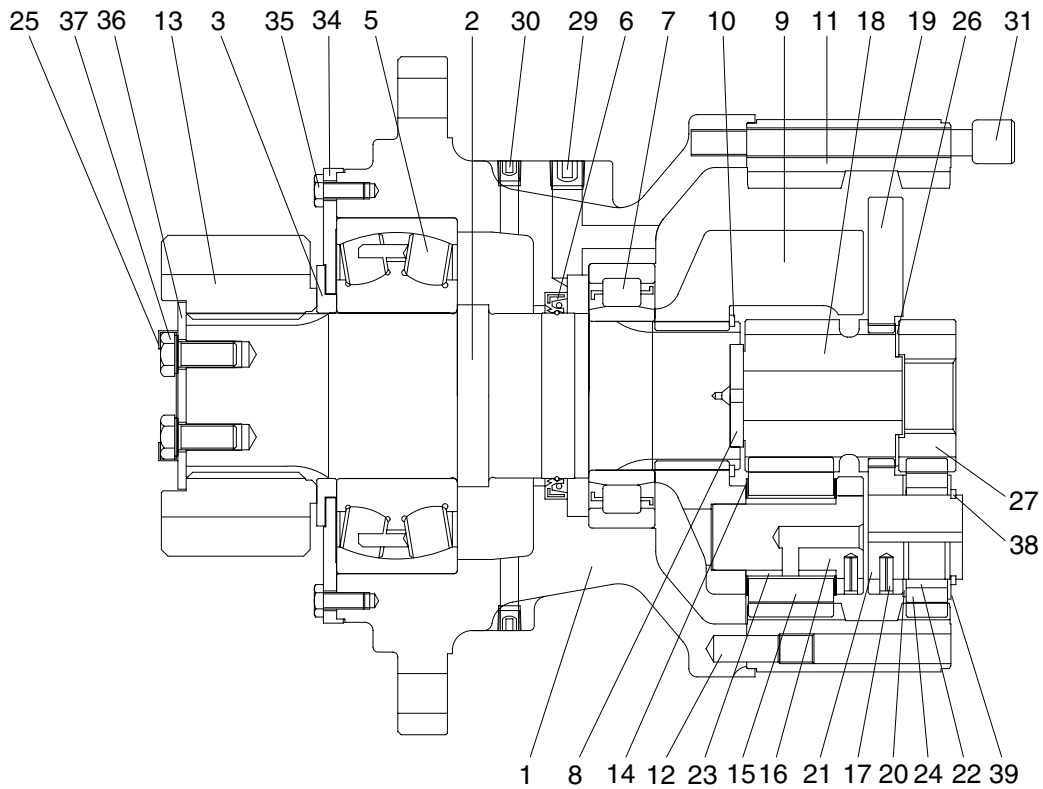

21092SM03

1	Casing	14	Thrust washer	26	Side plate 3
2	Drive shaft	15	Planet gear 2	27	Sun gear 1
3	Spacer	16	Pin & bushing	29	Plug
5	Roller bearing	17	Spring pin	30	Plug
6	Oil seal	18	Sun gear 2	31	Socket bolt
7	Roller bearing	19	Carrier 1	34	Cover plate
8	Thrust plate	20	Side plate 1	35	Hexagon bolt
9	Carrier 2	21	Pin 1	36	Lock plate
10	Stop ring	22	Needle cage	37	Hexagon bolt
11	Ring gear	23	Bushing 2	38	Stop ring
12	Knock pin	24	Planet gear 1	39	Side plate 2
13	Pinion gear	25	Lock washer		

## 2. PRINCIPLE OF DRIVING

### 2.1 Generating the turning force

The high hydraulic supplied from a hydraulic pump flows into a cylinder (10) through valve casing of motor (21), and valve plate (24).

The high hydraulic is built as flowing on one side of Y-Y line connected by the upper and lower sides of piston (14).

The high hydraulic can generate the force,  $F1 = P \times A$  ( $P$  : supplied pressure,  $A$  : water pressure area), like following pictures, working on a piston.

This force,  $F1$ , is divided as  $N1$  thrust partial pressure and  $W1$  radial partial pressure, in case of the plate of a tilt angle,  $\alpha$ .

$W1$  generates torque,  $T = W1 \times R1$ , for Y-Y line connected by the upper and lower sides of the piston as following pictures.

The sum of torque ( $\sum W1 \times R1$ ), generated from each piston (4~5 pieces) on the side of a high hydraulic, generates the turning force.

This torque transfers the turning force to a cylinder (10) through a piston; because a cylinder is combined with a turning axis and spline, a turning axis rotates and a turning force is sent.

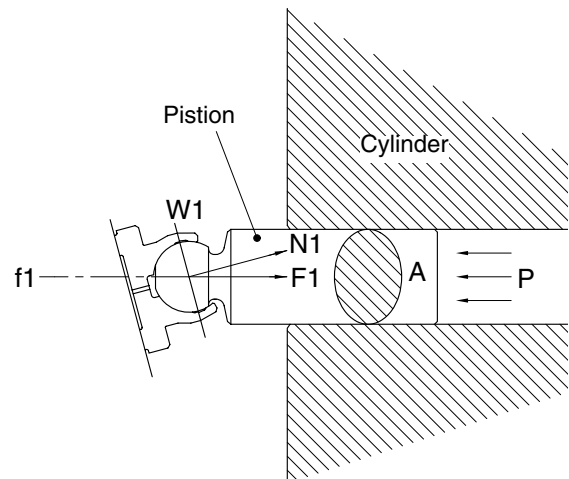
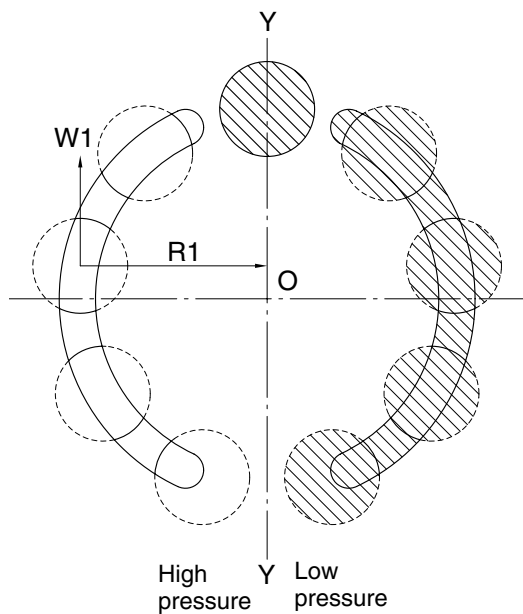

21078TM05

## 2) MAKE UP VALVE

In the system using this type of motor, there is no counter balance functioning valve and there happens the case of revolution exceeding hydraulic supply of motor. To prevent the cavitation caused by insufficient oil flow there is a make up valve to fill up the oil insufficiency.

A make up valve is provided immediately before the port leading to the hydraulic oil tank to secure feed pressure required when the hydraulic motor makes a pumping action. The boost pressure acts on the hydraulic motor's feed port via the make up valve.

Pressurized oil into the port B, the motor rotate counterclockwise.

If the plunger of MCV moves neutral position, the oil in the motor is drain via left relief valve, the drain oil run into motor via right make up valve, which prevent the cavitation of motor.

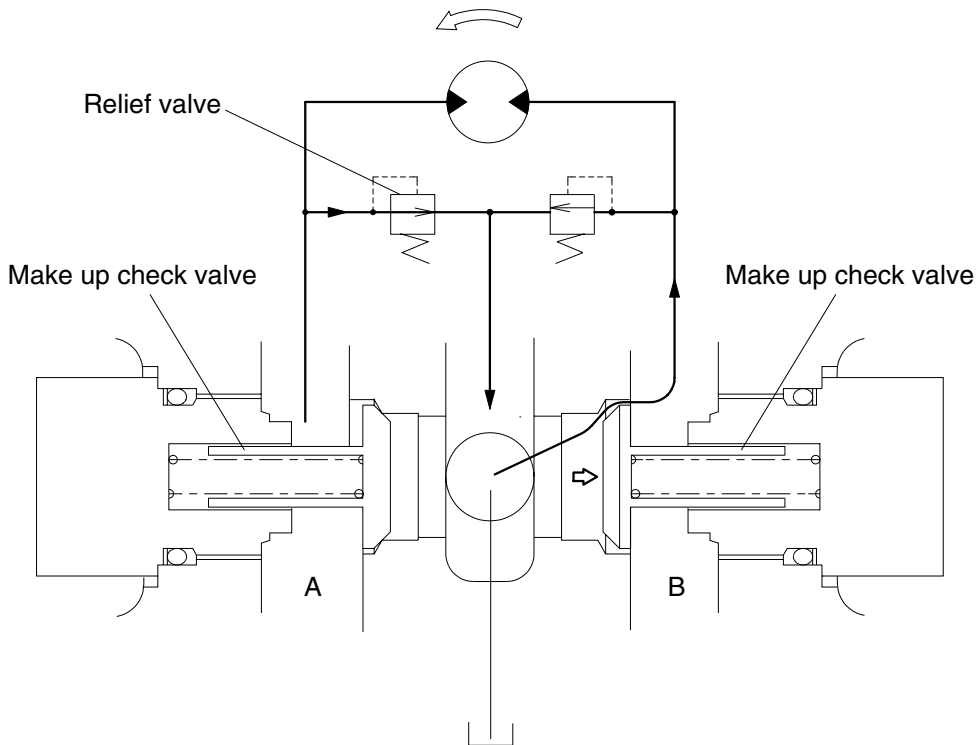

21092SM04

### 3) RELIEF VALVE

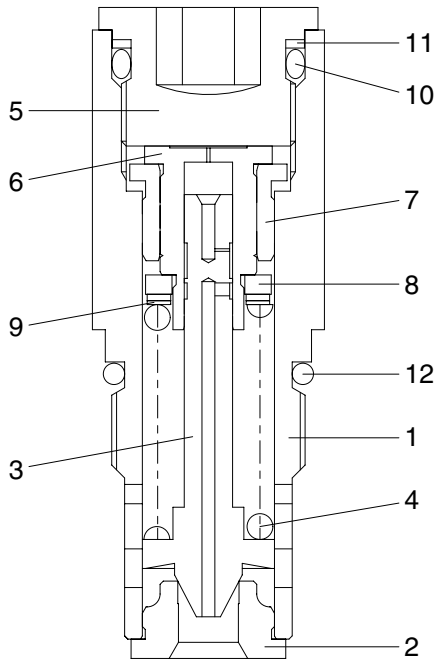

- 1 Body
- 2 Seat
- 3 Plunger
- 4 Spring
- 5 Adjusting screw
- 6 Piston
- 7 Bushing
- 8 Spring seat
- 9 Shim
- 10 O-ring
- 11 Back up ring
- 12 O-ring

14007A2SM05

#### (1) Construction of relief valve

The valve casing contains two cartridge type relief valves that stop the regular and reverse rotations of the hydraulic motor. The relief valves relieve high pressure at start or at stop of swing motion and can control the relief pressure in two steps, high and low, in order to insure smooth operation.

#### (2) Function of relief valve

Figure illustrates how the pressure acting on the relief valve is related to its rising process. Here is given the function, referring to the figure following page.

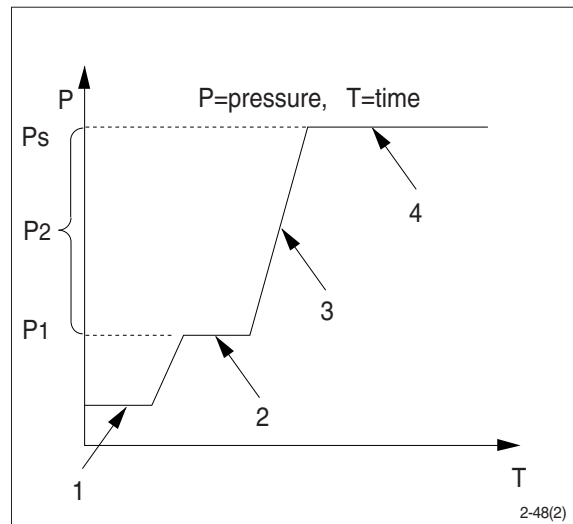

① Ports (P,R) at tank pressure.

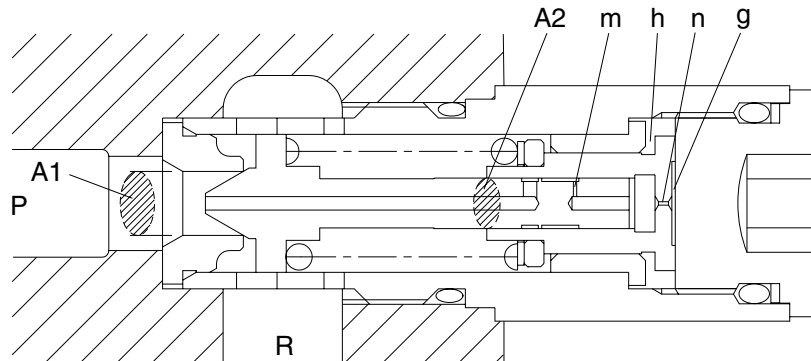

14007A2SM06

② When hydraulic oil pressure ( $P \times A_1$ ) reaches the preset force ( $F_{SP}$ ) of spring (4), the plunger (3) moves to the right as shown.

$$P_1 \times A_1 = F_{SP} + P_g \times A_2$$

$$P_1 = \frac{F_{SP} + P_g \times A_2}{A_1}$$

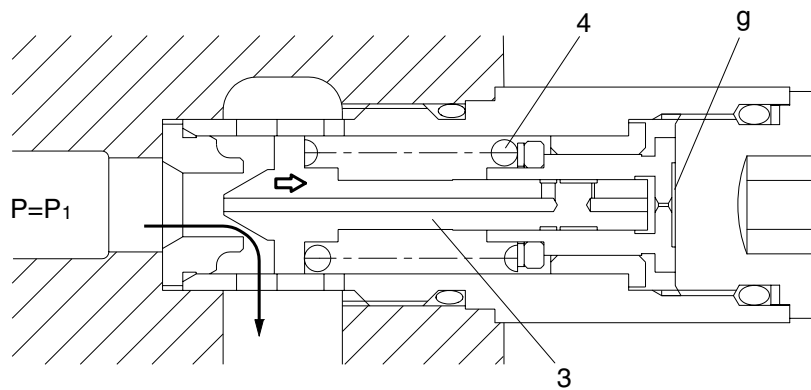

14007A2SM07

- ③ The oil flow chamber g via orifice m and n. When the pressure of chamber g reaches the preset force (FSP) of spring (4), the piston (6) moves left and stop the piston (6) hits the bottom of bushing (7).

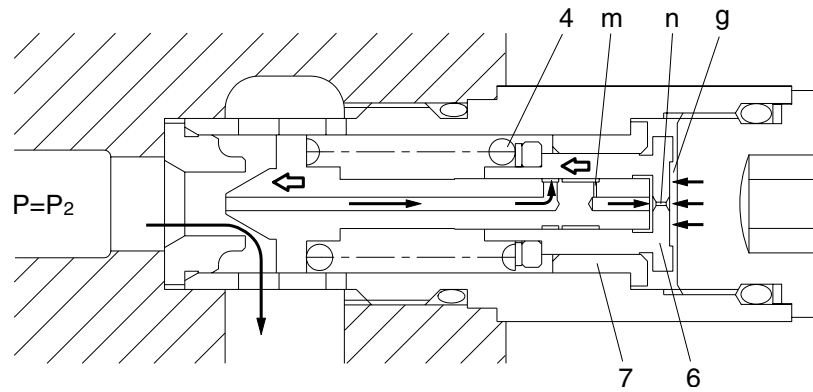

14007A2SM08

- ④ When piston (6) hits the bottom of bushing (7), it stops moving to the left any further. As the result, the pressure in chamber (g) equals (Ps).

$$P_s \times A_1 = F_{sp} + P_s \times A_2$$

$$P_s = \frac{F_{sp}}{A_1 - A_2}$$

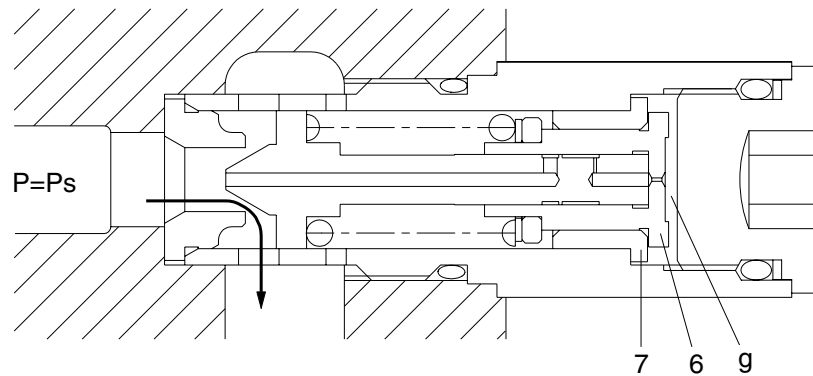

14007A2SM09

## 4) BRAKE SYSTEM

### (1) Control valve swing brake system

This is the brake system to stop the swing motion of the excavator during operation.

In this system, the hydraulic circuit is throttled by the swing control valve, and the resistance created by this throttling works as a brake force to slow down the swing motion.

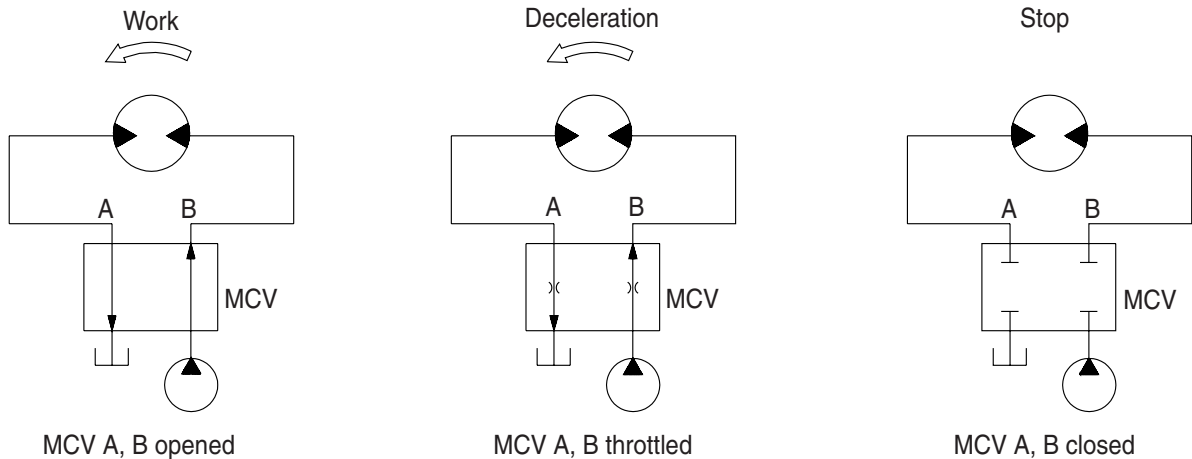

2-48(1)

### (2) Mechanical swing parking brake system

This is function as a parking brake only when all of the RCV lever (except travel pedal) are not operated.

#### ① Brake assembly

Circumferential rotation of separate plate (16) is constrained by the groove located at housing (1). When housing is pressed down by brake spring (20) through friction plate (15), separate plate (16) and brake piston (17), friction force occurs there.

Cylinder block (10) is constrained by this friction force and brake acts, while brake releases when hydraulic force exceeds spring force.

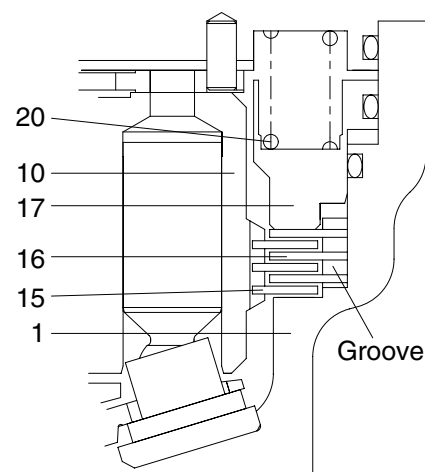

21092SM15

1	Housing	16	Separate plate
10	Cylinder block	17	Brake piston
15	Friction plate	20	Spring

② Operating principle

- a. When one of the RCV lever (1) is set to the operation position, the each spool is shifted to left or right and the pilot oil flow is blocked. Then the pilot oil go to SH of the time delay valve (35). This pressure moves spool (5) to the leftward against the force of the spring(8), so pilot pump charged oil (P3) goes to the chamber G through port PG. This pressure is applied to move the piston (17) to the upward against the force of the spring (20). Thus, it releases the brake force.

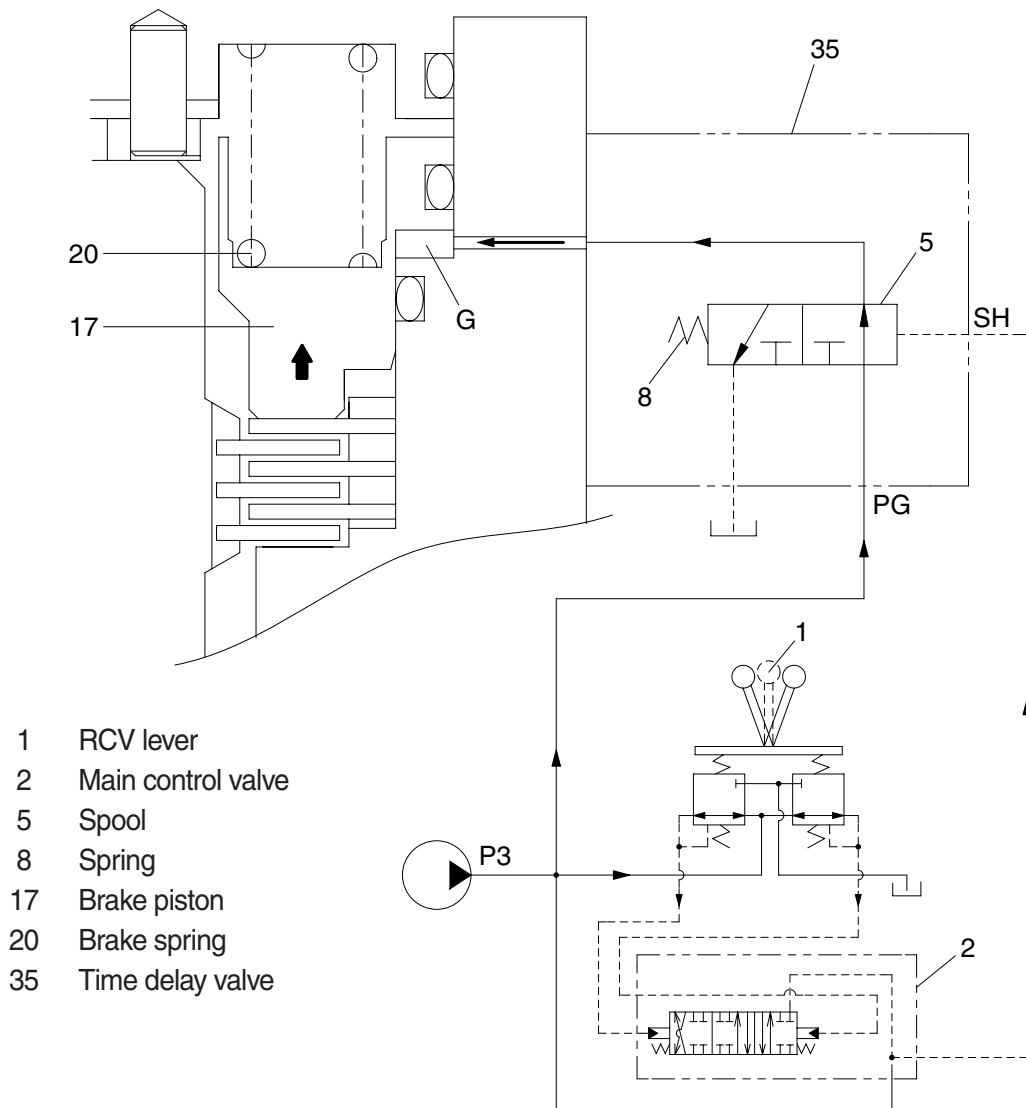

21092SM16

- b. When all of the RCV lever (1) are set the neutral position, the spool (5) returns to right. Then, the brake piston (17) is moved lower by spring force and the return oil from the chamber G flows back to tank port. At this time, the brake works.

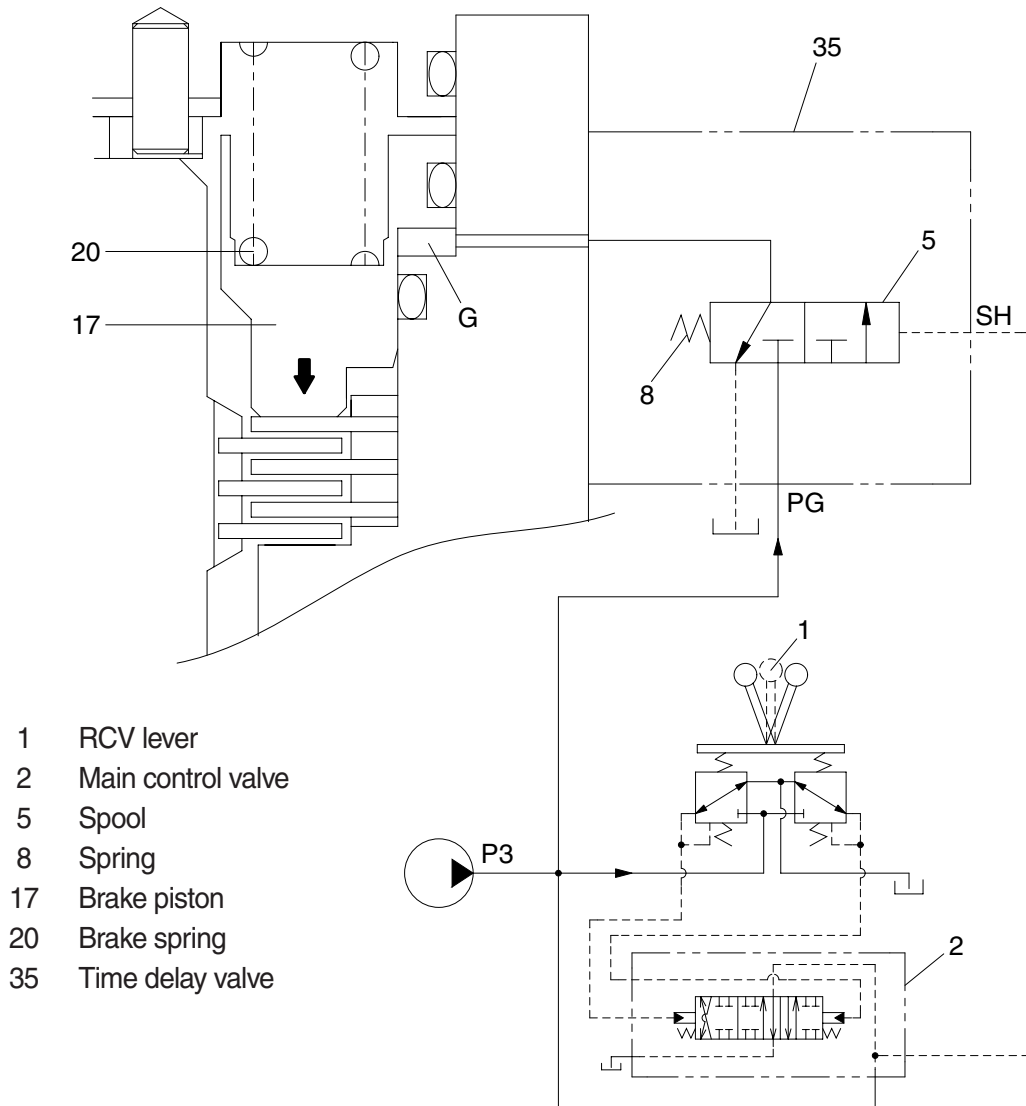

21092SM17