

GROUP 2 SPECIFICATIONS

1. MAJOR COMPONENT

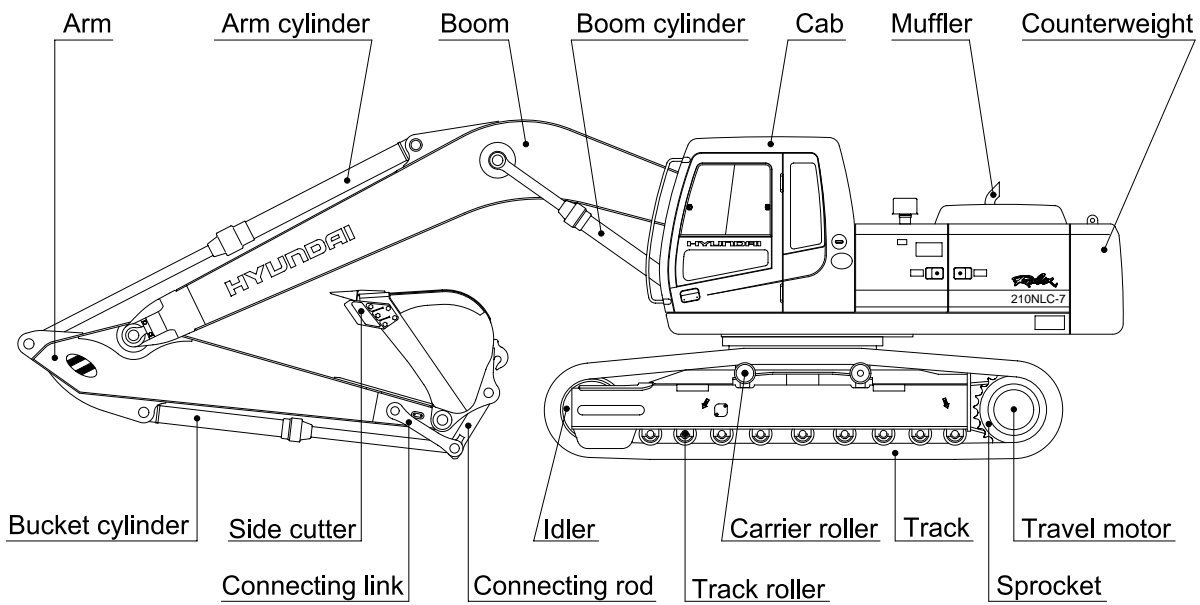
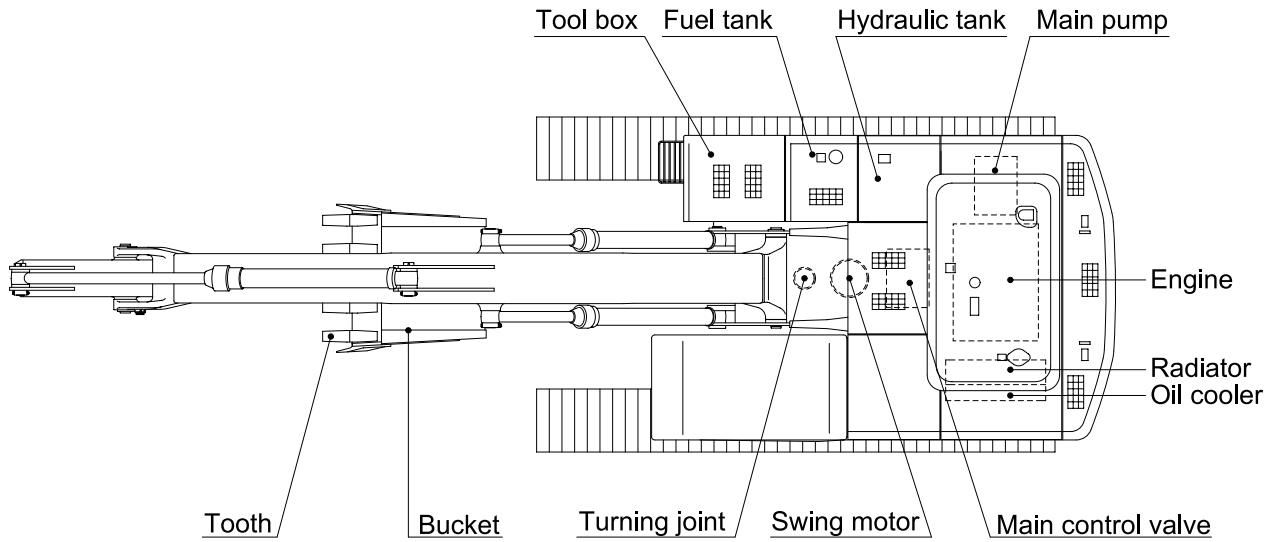

21072SP01A

2. SPECIFICATIONS

1) 5.68m(18' 8") MONO BOOM

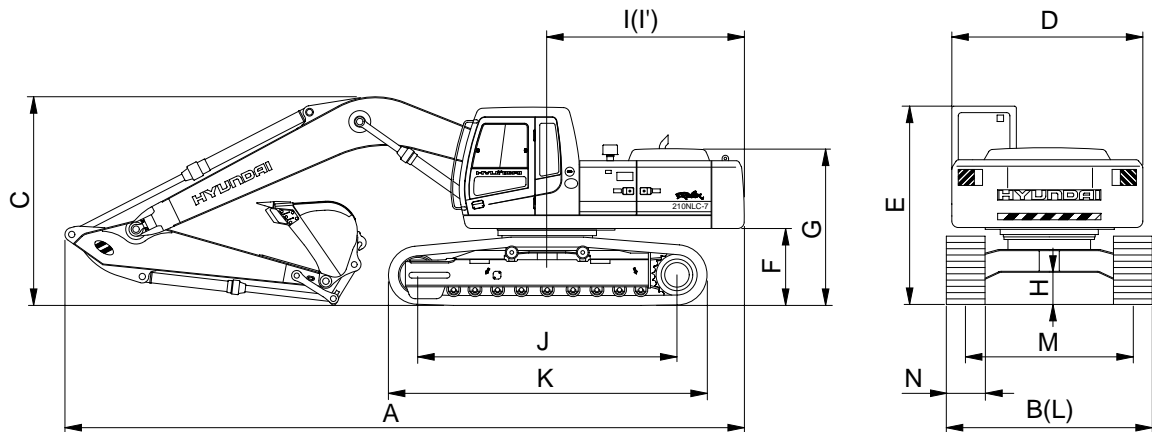

21072SP02

Description		Unit	Specification
Operating weight		kg(lb)	22000(48500)
Bucket capacity(SAE heaped), standard		m ³ (yd ³)	0.87(1.14)
Overall length	A	mm(ft-in)	9540(31' 4")
Overall width, with 500mm shoe	B		2500(8' 2")
Overall height	C		3070(10' 1")
Superstructure width	D		2530(8' 4")
Overall height of cab	E		2920(9' 7")
Ground clearance of counterweight	F		1060(3' 6")
Engine cover height	G		2320(7' 7")
Minimum ground clearance	H		480(1' 7")
Rear-end distance	I		2770(9' 1")
Rear-end swing radius	I'		2800(9' 2")
Distance between tumbler	J		3650(12' 0")
Undercarriage length	K		4440(14' 7")
Undercarriage width	L		2500(8' 2")
Track gauge	M		2000(6' 7")
Track shoe width, standard	N		500(20")
Travel speed(Low/high)		km/hr(mph)	3.4/5.3(2.1/3.3)
Swing speed		rpm	12.5
Gradeability		Degree(%)	35(70)
Ground pressure(500mm shoe)		kgf/cm ² (psi)	0.56(7.96)

2) 5.50m(18' 1") TWO PIECE BOOM

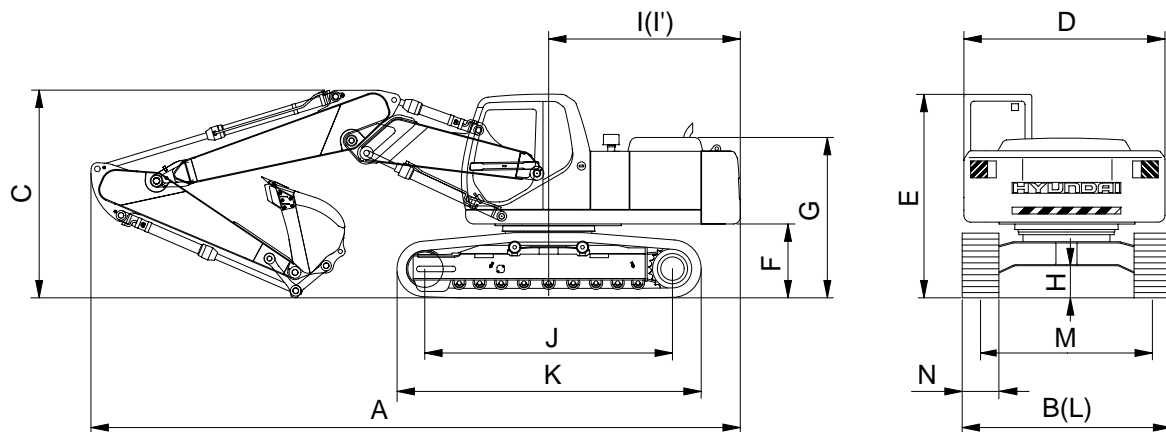

210N72SP06

Description		Unit	Specification
Operating weight		kg(lb)	21150(46630)
Bucket capacity(SAE heaped), standard		m ³ (yd ³)	0.87(1.14)
Overall length	A	mm(ft-in)	9390(30' 10")
Overall width, with 500mm shoe	B		2500(8' 2")
Overall height	C		3110(10' 2")
Superstructure width	D		2530(8' 4")
Overall height of cab	E		2920(9' 7")
Ground clearance of counterweight	F		1060(3' 6")
Engine cover height	G		2320(7' 7")
Minimum ground clearance	H		480(1' 7")
Rear-end distance	I		2770(9' 1")
Rear-end swing radius	I'		2800(9' 2")
Distance between tumblers	J		3650(12' 0")
Undercarriage length	K		4440(14' 7")
Undercarriage width	L		2500(8' 2")
Track gauge	M		2000(6' 7")
Track shoe width, standard	N		500(20")
Travel speed(Low/high)		km/hr(mph)	3.4/5.3(2.1/3.3)
Swing speed		rpm	12.5
Gradeability		Degree(%)	35(70)
Ground pressure(500mm shoe)		kgf/cm ² (psi)	0.56(7.96)

3. WORKING RANGE

1) 5.68m(18' 8") MONO BOOM

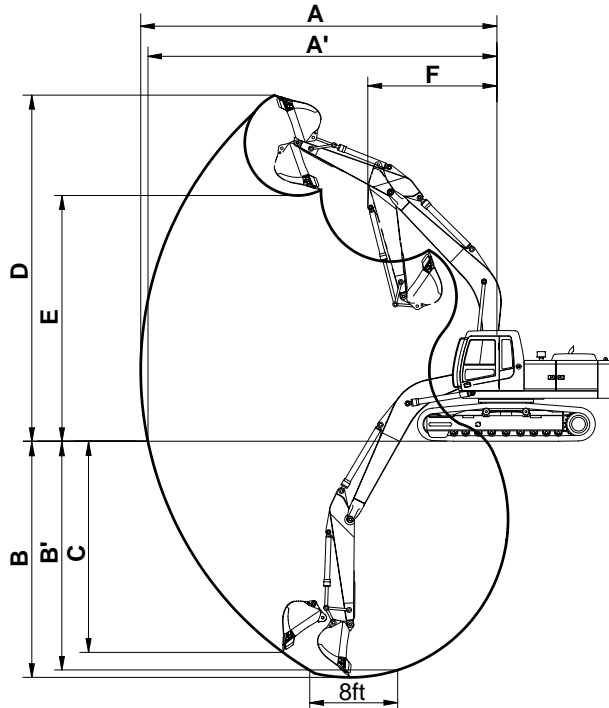

21072SP03

Description		2.0m(6' 7") Arm	2.40m(7' 10") Arm	2.92m(9' 7") Arm
Max digging reach	A	9140mm (30' 0")	9510mm (31' 2")	9960mm (32' 8")
Max digging reach on ground	A'	8960mm (29' 5")	9340mm (30' 8")	9790mm (32' 1")
Max digging depth	B	5750mm (18'10")	6150mm (20' 2")	6670mm (22'11")
Max digging depth (8ft level)	B'	5520mm (18' 1")	5950mm (19' 6")	6490mm (21' 4")
Max vertical wall digging depth	C	5320mm (17' 5")	5780mm (19' 0")	6180mm (20' 3")
Max digging height	D	9270mm (30' 5")	9500mm (31' 2")	9660mm (31' 8")
Max dumping height	E	6450mm (21' 2")	6660mm (21'10")	6840mm (22' 5")
Min swing radius	F	3710mm (12' 2")	3630mm (11'11")	3550mm (11' 8")
Bucket digging force	SAE	133 [146]kN	133 [146] kN	133 [146] kN
		13600 [14840]kgf	13600 [14840] kgf	13600 [14840] kgf
		29980 [32710]lbf	29980 [32710] lbf	29980 [32710] lbf
	ISO	152 [166]kN	152 [166] kN	152 [166] kN
		15500 [16910]kgf	15500 [16910] kgf	15500 [16910] kgf
		34170 [37280]lbf	34170 [37280] lbf	34170 [37280] lbf
Arm digging force	SAE	135 [148]kN	113 [123] kN	97 [106] kN
		13800 [15050]kgf	11500 [12550] kgf	9900 [10800] kgf
		30420 [33190]lbf	25350 [27650] lbf	21830 [23810] lbf
	ISO	142 [155]kN	118 [128] kN	101 [110] kN
		14500 [15820]kgf	12000 [13090] kgf	10300 [11240] kgf
		31970 [34880]lbf	26460 [28870] lbf	22710 [24770] lbf

[] : Power boost

2) 5.50m(18' 1") TWO PIECE BOOM

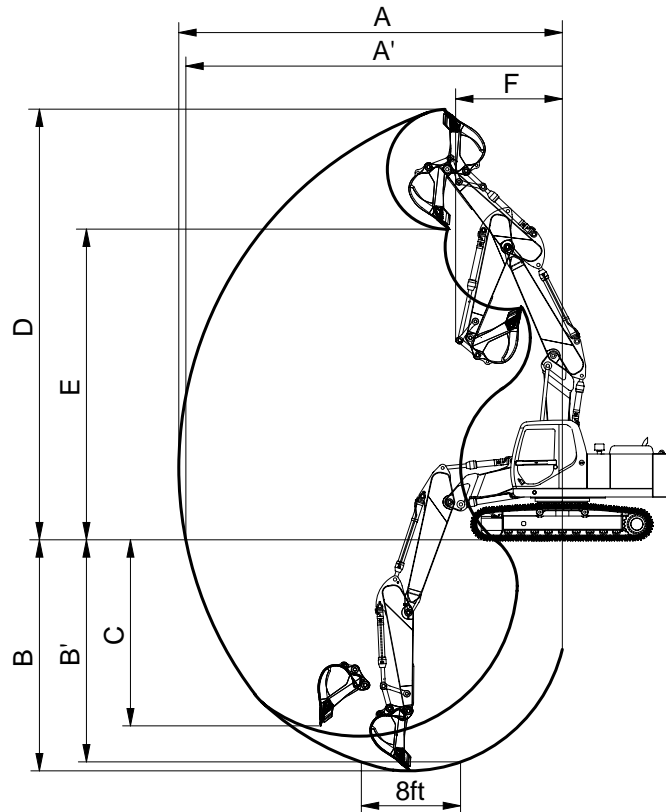

210N72SP08

Description		2.0m(6' 7") Arm	2.40m(7' 10") Arm
Max digging reach	A	8990(29' 6")	9370(30' 9")
Max digging reach on ground	A'	8810(28'11")	9200(30' 2")
Max digging depth	B	5240(17' 2")	5640(18' 6")
Max digging depth (8ft level)	B'	4950(16' 3")	5380(17' 8")
Max vertical wall digging depth	C	4030(13' 3")	4500(14' 9")
Max digging height	D	10200(33' 6")	10520(34' 6")
Max dumping height	E	7270(23'10")	7590(24'11")
Min swing radius	F	2830(9' 3")	2610(8' 7")
Bucket digging force	SAE	133 [146]kN	133 [146]kN
		13600 [14840]kgf	13600 [14840]kgf
		29980 [32710]lbf	29980 [32710]lbf
	ISO	152 [166]kN	152 [166]kN
		15500 [16910]kgf	15500 [16910]kgf
		34170 [37280]lbf	34170 [37280]lbf
Arm crowd force	SAE	135 [148]kN	113 [123]kN
		13800 [15050]kgf	11500 [12550]kgf
		30420 [33190]lbf	25350 [27650]lbf
	ISO	142 [155]kN	118 [128]kN
		14500 [15820]kgf	12000 [13090]kgf
		31970 [34880]lbf	26460 [28870]lbf

[] : Power boost

4. WEIGHT

1) MONO BOOM

Item	R210NLC-7	
	kg	lb
Upperstructure assembly	8950	19730
Main frame weld assembly	2600	5730
Engine assembly	430	950
Engine assembly	530	1170
Main pump assembly	170	370
Main control valve assembly	200	440
Swing motor assembly	190	420
Hydraulic oil tank assembly	240	530
Fuel tank assembly	195	430
Counterweight	4700	10360
Cab assembly	310	680
Lower chassis assembly	8400	18520
Track frame weld assembly	2525	5570
Swing bearing	260	570
Travel motor assembly	305	670
Turning joint	55	120
Track recoil spring and idler	270	600
Idler	170	370
Carrier roller	20	45
Track roller	40	90
Track-chain assembly(500mm standard triple grouser shoe)	1200	2650
Front attachment assembly(5.68m boom, 2.92m arm, 0.87m ³ SAE heaped bucket)	4050	8930
5.68m boom assembly	1500	3310
2.92m arm assembly	705	1550
0.87m ³ SAE heaped bucket	710	1570
Boom cylinder assembly	180	400
Arm cylinder assembly	290	640
Bucket cylinder assembly	175	390
Bucket control link assembly	170	370

2) TWO PIECE BOOM











Item	R210NLC-7	
	kg	lb
Upperstructure assembly	8950	19730
Main frame weld assembly	2600	5730
Engine assembly	430	950
Engine assembly	530	1170
Main pump assembly	170	370
Main control valve assembly	200	440
Swing motor assembly	190	420
Hydraulic oil tank assembly	240	530
Fuel tank assembly	195	430
Counterweight	4700	10360
Cab assembly	310	680
Lower chassis assembly	8400	18520
Track frame weld assembly	2525	5570
Swing bearing	260	570
Travel motor assembly	305	670
Turning joint	55	120
Track recoil spring and idler	270	600
Idler	170	370
Carrier roller	20	45
Track roller	40	90
Track-chain assembly(500mm standard triple grouser shoe)	1200	2650
Front attachment assembly(5.5m boom, 2.4m arm, 0.87m ³ SAE heaped bucket)	3185	7020
5.5m boom assembly	1810	3990
2.4m arm assembly	665	1470
0.87m ³ SAE heaped bucket	710	1570
Boom cylinder assembly	185	410
Arm cylinder assembly	290	640
Bucket cylinder assembly	175	390
Adjust cylinder assembly	200	440
Bucket control rod assembly	170	370

5. LIFTING CAPACITIES

1) MONO BOOM













(1) 5.68m(18' 8") boom, 2.00m(6' 7") arm equipped with 0.87m³(SAE heaped) bucket, 500mm(20") triple grouser shoe and 4700kg(10360lb) counterweight.

-  : Rating over-front
-  : Rating over-side or 360 degree













Load point height		Load radius								At max. reach		
		3.0m(10ft)		4.5m(15ft)		6.0m(20ft)		7.5m(25ft)		Capacity		Reach
												m(ft)
7.5m (25ft)	kg lb									*3740 *8250	3590 7910	6.65 (21.8)
6.0m (20ft)	kg lb					*4130 *9110	*4130 *9110			*3800 *8380	2640 5820	7.78 (25.5)
4.5m (15ft)	kg lb			*5340 *11770	*5340 *11770	*4530 *9990	4010 8840			*3910 *8620	2200 4850	8.44 (27.7)
3.0m (10ft)	kg lb			*6950 *15320	5820 12830	*5230 *11530	3770 8310	*4500 *9920	2590 5710	*4060 *8950	1990 4390	8.74 (28.7)
1.5m (5ft)	kg lb			*8390 *18500	5330 11750	*5960 *13140	3530 7780	*4830 *10650	2480 5470	4130 9110	1950 4300	8.74 (28.7)
Ground Line	kg lb			*9050 *19950	5120 11290	*6450 *14220	3370 7430	*5060 *11160	2410 5310	4350 9590	2050 4520	8.43 (27.7)
-1.5m (-5ft)	kg lb	*13120 *28920	9870 21760	*9010 *19860	5090 11220	*6540 *14420	3320 7320			*4580 *10100	2360 5200	7.76 (25.5)
-3.0m (-10ft)	kg lb	*11750 *25900	10070 22200	*8270 *18230	5200 11460	*5960 *13140	3410 7520			*4550 *10030	3140 6920	6.62 (21.7)

- Note
1. Lifting capacity are based on SAE J1097 and ISO 10567.
 2. Lifting capacity of the ROBEX series does not exceed 75% of tipping load with the machine on firm, level ground or 87% of full hydraulic capacity.
 3. The load point is a hook located on the back of the bucket.
 4. *indicates load limited by hydraulic capacity.

(2) 5.68m(18' 8") boom, 2.40m(7' 10") arm equipped with 0.87m³(SAE heaped) bucket, 500mm(20") triple grouser shoe and 4700kg(10360lb) counterweight.

Load point height		Load radius										At max. reach					
		1.5m(5ft)		3.0m(10ft)		4.5m(15ft)		6.0m(20ft)		7.5m(25ft)		Capacity		Reach			
														m(ft)			
7.5m (25ft)	kg lb														*3450 *7610	3160 6970	7.16 (23.5)
6.0m (20ft)	kg lb							*3730 *8220	*3730 *8220					*3520 *7760	2390 5270	8.21 (26.9)	
4.5m (15ft)	kg lb					*4800 *10580	*4800 *10580	*4170 *9190	4060 8950	*3930 *8660	2700 5950	*3640 *8020	2010 4430	8.83 (29.0)			
3.0m (10ft)	kg lb					*6410 *14130	5910 13030	*4910 *10820	3790 8360	*4240 *9350	2590 5710	*3780 *8330	1830 4030	9.12 (29.9)			
1.5m (5ft)	kg lb					*7960 *17550	5370 11840	*5690 *12540	3520 7760	*4630 *10210	2470 5450	3830 8440	1780 3920	9.11 (29.9)			
Ground Line	kg lb			*8350 *18410	*8350 *18410	*8840 *19490	5080 11200	*6280 *13850	3340 7360	*4930 *10870	2370 5220	4010 8840	1860 4100	8.82 (28.9)			
-1.5m (-5ft)	kg lb	*9270 *20440	*9270 *20440	*12800 *28220	9660 21300	*9010 *19860	5010 11050	*6490 *14310	3260 7190			*4320 *9520	2120 4670	8.19 (26.9)			
-3.0m (-10ft)	kg lb	*13370 *29480	*13370 *29480	*12400 *27340	9850 21720	*8500 *18740	5080 11200	*6160 *13580	3300 7280			*4390 *9680	2730 6020	7.13 (23.4)			
-4.5m (-15ft)	kg lb			*9980 *22000	*9980 *22000	*6940 *15300	5320 11730										











(3) 5.68m(18' 8") boom, 2.92m(12' 9") arm equipped with 0.87m³(SAE heaped) bucket, 500mm(20") triple grouser shoe and 4700kg(10360lb) counterweight.

Load point height		Load radius										At max. reach				
		1.5m(5ft)		3.0m(10ft)		4.5m(15ft)		6.0m(20ft)		7.5m(25ft)		Capacity		Reach		
														m(ft)		
7.5m (25ft)	kg lb													*3130 *6900	2790 6150	7.75 (25.4)
6.0m (20ft)	kg lb									*2000 *4410	*2000 *4410	*3220 *7100	2170 4780	8.71 (28.6)		
4.5m (15ft)	kg lb							*3750 *8270	*3750 *8270	*3580 *7890	2770 6110	*3350 *7390	1840 4060	9.29 (30.5)		
3.0m (10ft)	kg lb			*9130 *20130	*9130 *20130	*5750 *12680	*5750 *12680	*4520 *9960	3870 8530	*3950 *8710	2640 5820	*3500 *7720	1680 3700	9.56 (31.4)		
1.5m (5ft)	kg lb			*8720 *19220	*8720 *19220	*7430 *16380	5500 12130	*5380 *11860	3580 7890	*4400 *9700	2490 5490	3550 7830	1630 3590	9.56 (31.4)		
Ground Line	kg lb			*9350 *20610	*9350 *20610	*8570 *18890	5130 11310	*6070 *13380	3360 7410	*4790 *10560	2370 5220	3690 8140	1690 3730	9.28 (30.4)		
-1.5m (-5ft)	kg lb	*8590 *18940	*8590 *18940	*12200 *26900	9550 21050	*8990 *19820	4990 11000	*6430 *14180	3240 7140	*4970 *10960	2310 5090	*4080 *8990	1890 4170	8.69 (28.5)		
-3.0m (-10ft)	kg lb	*11720 *25840	*11720 *25840	*13130 *28950	9690 21360	*8740 *1927	5000 11020	*6320 *13930	3240 7140			*4250 *9370	2350 5180	7.72 (25.3)		
-4.5m (-15ft)	kg lb			*11170 *24630	10000 22050	*7640 *16840	5170 11400					*4170 *9190	3550 7830	6.12 (20.1)		

2) TWO PIECE BOOM











(1) 5.5m(18' 1") boom, 2.4m(7'10") arm equipped with 0.87m³(SAE heaped) bucket, 500mm(20") triple grouser shoe and 4700kg(10360lb) counterweight.

-  : Rating over-front
-  : Rating over-side or 360 degree

Load point height		Load radius								At max. reach		
		3.0m(10ft)		4.5m(15ft)		6.0m(20ft)		7.5m(25ft)		Capacity		Reach
												m(ft)
9.0m (30ft)	kg lb									*5690 *12540	*5690 *12540	5.09 (16.7)
7.5m (25ft)	kg lb			*5380 *11860	*5380 *11860					*4790 *10560	3310 7300	6.97 (22.9)
6.0m (20ft)	kg lb			*6140 *13540	*6140 *13540	*5290 *11660	4230 9330			*4450 *9810	2480 5470	8.05 (26.4)
4.5m (15ft)	kg lb	*9590 *21140	*9590 *21140	*6950 *15320	6590 14530	*5650 *12460	4070 8970	*3340 *7360	2700 5950	*4260 *9390	2080 4590	8.68 (28.5)
3.0m (10ft)	kg lb	*13110 *28900	11070 24410	*8130 *17920	5990 13210	*6120 *13490	3820 8420	*5000 *11020	2600 5730	4020 8860	1890 4170	8.98 (29.5)
1.5m (5ft)	kg lb			*9020 *19890	5440 11990	*6520 *14370	3560 7850	*5090 *11220	2480 5470	*3970 *8750	1840 4060	8.97 (29.4)
Ground Line	kg lb	*9090 *20040	*9090 *20040	*9060 *19970	2140 11330	*6550 *14440	3370 7430	*4930 *10870	2390 5270	*3730 *8220	1940 4280	8.67 (28.4)
-1.5m (-5ft)	kg lb	*11050 *24360	9740 21470	*8210 *18100	5060 11160	*6020 *13270	3300 7280			*3280 *7230	2220 4890	8.03 (26.3)
-3.0m (-10ft)	kg lb			*6420 *14150	5140 11330	*4570 *10080	3360 7410					

- Note
1. Lifting capacity are based on SAE J1097 and ISO 10567.
 2. Lifting capacity of the ROBEX series does not exceed 75% of tipping load with the machine on firm, level ground or 87% of full hydraulic capacity.
 3. The load point is a hook located on the back of the bucket.
 4. *indicates load limited by hydraulic capacity.

(2) 5.5m(18' 1") boom, 2.0m(6' 7") arm equipped with 0.87m³(SAE heaped) bucket, 500mm(20") triple grouser shoe and 4700kg(10360lb) counterweight.

Load point height		Load radius								At max. reach		
		3.0m(10ft)		4.5m(15ft)		6.0m(20ft)		7.5m(25.0ft)		Capacity		Reach
												m(ft)
10.5m (35ft)	kg lb									*5640 *12430	*5640 *12430	4.97 (16.3)
9.0m (30ft)	kg lb									*6620 *14590	*6620 *14590	4.24 (13.9)
7.5m (25ft)	kg lb			*6540 *14420	*6540 *14420					*5230 *11530	3790 8360	6.45 (21.2)
6.0m (20ft)	kg lb			*6600 *14550	*6600 *14550	*5700 *12570	4160 9170			*4800 *10580	2750 6060	7.61 (25.0)
4.5m (15ft)	kg lb	*10600 *23370	*10600 *23370	*7400 *16310	6470 14260	*5920 *13050	4030 8880			*4570 *10080	2280 5030	8.28 (27.2)
3.0m (10ft)	kg lb			*8520 *18780	5890 12990	*6350 *14000	3790 8360	*5140 *11330	2600 5730	4330 9550	2060 4540	8.59 (28.2)
1.5m (5ft)	kg lb			*9210 *20300	5400 11900	*6650 *14660	3560 7850	*5140 *11330	2500 5510	*4210 *9280	2020 4450	8.59 (28.2)
Ground Line	kg lb			*8980 *19800	5170 11400	*6550 *14440	3400 7500			*3910 *8620	2130 4700	8.27 (27.1)
-1.5m (-5ft)	kg lb	*9830 *21670	*9830 *21670	*7870 *17350	5140 11330	*5810 *12810	3360 7410			*3330 *7340	2480 5470	7.59 (24.9)
-3.0m (-10ft)	kg lb			*5770 *12720	5260 11600							

6. BUCKET SELECTION GUIDE

1) GENERAL BUCKET

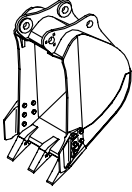
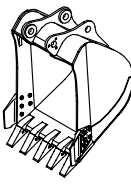
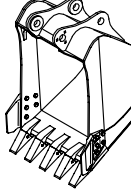
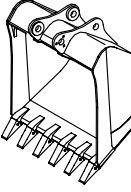
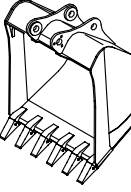
				
0.51m ³ SAE heaped bucket	0.80m ³ SAE heaped bucket	0.87m ³ SAE heaped bucket	1.20m ³ SAE heaped bucket	1.34m ³ SAE heaped bucket

Capacity		Width		Weight	Recommendation		
					5.68m (18' 8") boom		
SAE heaped	CECE heaped	Without side cutter	With side cutter		2.0m arm (6' 7")	2.4m arm (7' 10")	2.92m arm (9' 7")
0.51m ³ (0.67yd ³)	0.45m ³ (0.59yd ³)	700mm (27.6")	820mm (32.3")	580kg (1280lb)			
0.80m ³ (1.05yd ³)	0.70m ³ (0.92yd ³)	1000mm (39.4")	1120mm (44.1")	650kg (1430lb)			
0.87m ³ (1.14yd ³)	0.75m ³ (0.98yd ³)	1090mm (42.9")	1210mm (47.6")	685kg (1510lb)			
1.20m ³ (1.57yd ³)	1.00m ³ (1.31yd ³)	1400mm (55.1")		770kg (1700lb)			
1.34m ³ (1.75yd ³)	1.15m ³ (1.50yd ³)	1550mm (61.0")		800kg (1760lb)			

: Standard bucket

 Applicable for materials with density of 2000kgf/m³ (3370lbf/yd³) or less

 Applicable for materials with density of 1600kgf/m³ (2700lbf/yd³) or less

 Applicable for materials with density of 1100kgf/m³ (1850lbf/yd³) or less

2) HEAVY DUTY, ROCK AND SLOPE FINISHING BUCKET

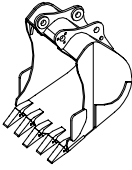
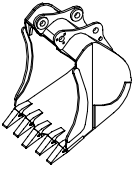
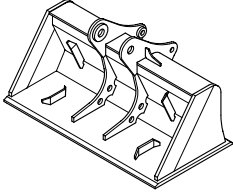
		
0.74, 0.90, 1.05m ³ SAE heaped bucket	≡0.87m ³ SAE heaped bucket	0.75m ³ SAE heaped bucket

Capacity		Width		Weight	Recommendation		
					5.68m (18' 8") boom		
SAE heaped	CECE heaped	Without side cutter	With side cutter		2.0m arm (6' 7")	2.4m arm (7' 10")	2.92m arm (9' 7")
0.74m ³ (0.97yd ³)	0.65m ³ (0.85yd ³)	915mm (36.0")		750kg (1650lb)			
0.90m ³ (1.18yd ³)	0.80m ³ (1.05yd ³)	1070mm (42.1")		790kg (1740lb)			
1.05m ³ (1.37yd ³)	0.92m ³ (1.20yd ³)	1220mm (48.0")		870kg (1920lb)			
≡0.87m ³ (1.14yd ³)	0.75m ³ (0.98yd ³)	1140mm (44.9")		860kg (1900lb)			
0.75m ³ (0.98yd ³)	0.65m ³ (0.85yd ³)	1810mm (71.3")		880kg (1940lb)			

: Heavy duty bucket ≡ : Rock bucket(Heavy) : Slope finishing bucket

 Applicable for materials with density of 2000kgf/m³ (3370lbf/yd³) or less

 Applicable for materials with density of 1600kgf/m³ (2700lbf/yd³) or less

 Applicable for materials with density of 1100kgf/m³ (1850lbf/yd³) or less

7. UNDERCARRIAGE

1) TRACKS

X-leg type center frame is integrally welded with reinforced box-section track frames. The design includes dry tracks, lubricated rollers, idlers, sprockets, hydraulic track adjusters with shock absorbing springs and assembled track-type tractor shoes with triple grousers.

2) TYPES OF SHOES

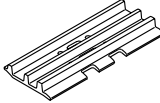
Model	Shapes		Triple grouser		
					
MONO BOOM	Shoe width	mm(in)	500(20)	600(24)	700(28)
	Operating weight	kg(lb)	22000(48500)	22300(49200)	22600(49820)
	Ground pressure	kgf/cm ² (psi)	0.56(7.96)	0.47(6.68)	0.41(5.83)
	Overall width	mm(ft-in)	2500(8' 2")	2600(8' 6")	2700(8'10")
2 PIECE BOOM	Shoe width	mm(in)	500(20)	600(24)	-
	Operating weight	kg(lb)	21150(46630)	21450(47290)	-
	Ground pressure	kgf/cm ² (psi)	0.56(7.96)	0.48(6.83)	-
	Overall width	mm(ft-in)	2500(8' 2")	2600(8' 6")	-

3) NUMBER OF ROLLERS AND SHOES ON EACH SIDE

Item	Quantity
Carrier rollers	2EA
Track rollers	9EA
Track shoes	49EA

4) SELECTION OF TRACK SHOE

Suitable track shoes should be selected according to operating conditions.

Method of selecting shoes

Confirm the category from the list of applications in **table 2**, then use **table 1** to select the shoe. Wide shoes(Categories B and C) have limitations on applications. Before using wide shoes, check the precautions, then investigate and study the operating conditions to confirm if these shoes are suitable.

Select the narrowest shoe possible to meet the required flotation and ground pressure. Application of wider shoes than recommendations will cause unexpected problem such as bending of shoes, crack of link, breakage of pin, loosening of shoe bolts and the other various problems.

Table 1

Track shoe	Specification	Category
500mm triple grouser	Standard	A
600mm triple grouser	Option	B
700mm triple grouser	Option	C

Table 2

Category	Applications	Precautions
A	Rocky ground, river beds, normal soil	<ul style="list-style-type: none"> Travel at low speed on rough ground with large obstacles such as boulders or fallen trees
B	Normal soil, soft ground	<ul style="list-style-type: none"> These shoes cannot be used on rough ground with large obstacles such as boulders or fallen trees Travel at high speed only on flat ground Travel slowly at low speed if it is impossible to avoid going over obstacles
C	Extremely soft ground (Swampy ground)	<ul style="list-style-type: none"> Use the shoes only in the conditions that the machine sinks and it is impossible to use the shoes of category A or B These shoes cannot be used on rough ground with large obstacles such as boulders or fallen trees Travel at high speed only on flat ground Travel slowly at low speed if it is impossible to avoid going over obstacles

8. SPECIFICATIONS FOR MAJOR COMPONENTS

1) ENGINE

Item	Specification
Model	Cummins 6BTAA
Type	4-cycle, turbocharged, charge air cooled, diesel engine, low emission
Cooling method	Water cooling
Number of cylinders and arrangement	6 cylinders, in-line
Firing order	1-5-3-6-2-4
Combustion chamber type	Direct injection type
Cylinder bore x stroke	102 x 120mm(4.02" x 4.72")
Piston displacement	5880cc(359cu in)
Compression ratio	17.3 : 1
Rated gross horse power(SAE J1349)	150Hp at 1950rpm(112kW at 1950rpm)
Maximum torque at 1500rpm	62.6kgf · m(453lbf · ft)
Engine oil quantity	24 (6.3U.S. gal)
Dry weight	496kg(1094lb)
High idling speed	2180+ 50rpm
Low idling speed	1050 ± 100rpm
Rated fuel consumption	164.8g/Hp · hr at 1950rpm
Starting motor	Nippon denso(24V-4.5kW)
Alternator	Delco Remy (24V-50A)
Battery	2 x 12V x 160Ah

2) MAIN PUMP

Item	Specification
Type	Variable displacement tandem axis piston pumps
Capacity	2 x 113cc/rev
Maximum pressure	330kgf/cm ² (4694psi) [360kgf/cm ² (5120psi)]
Rated oil flow	2 x 220 /min (58.1U.S. gpm/ 48.4U.K. gpm)
Rated speed	1950rpm

[] : Power boost

3) GEAR PUMP

Item	Specification
Type	Fixed displacement gear pump single stage
Capacity	15cc/rev
Maximum pressure	35kgf/cm ² (500psi)
Rated oil flow	29.3 l /min(7.7U.S. gpm/6.4U.K. gpm)

4) MAIN CONTROL VALVE

Item	Specification
Type	9 spools mono-block
Operating method	Hydraulic pilot system
Main relief valve pressure	330kgf/cm ² (4695psi) [360kgf/cm ² (5120psi)]
Overload relief valve pressure	390kgf/cm ² (5550psi)

[]: Power boost

5) SWING MOTOR

Item	Specification
Type	Two fixed displacement axial piston motor
Capacity	151cc/rev
Relief pressure	240kgf/cm ² (3414psi)
Braking system	Automatic, spring applied hydraulic released
Braking torque	59kgf · m(427lbf · ft)
Brake release pressure	33~50kgf/cm ² (470~711psi)
Reduction gear type	2 - stage planetary
Swing speed	12.5rpm

6) TRAVEL MOTOR

Item	Specification	
Model	GM35VL(up to #0099)	SBTR220(#0110 and up)
Type	Variable displacement axial piston motor	
Relief pressure	330kgf/cm ² (4695psi)	
Reduction gear type	3-stage planetary	2-stage planetary
Braking system	Automatic, spring applied hydraulic released	
Brake release pressure	6kgf/cm ² (85psi)	11kgf · m(156psi)
Braking torque	40.6kgf · m(294lbf · ft)	49.3kgf · m(357lbf · ft)

7) REMOTE CONTROL VALVE

Item		Specification
Type		Pressure reducing type
Operating pressure	Minimum	6.5kgf/cm ² (92psi)
	Maximum	26kgf/cm ² (370psi)
Single operation stroke	Lever	61mm(2.4in)
	Pedal	123mm(4.84in)

8) CYLINDER

Item		Specification
Boom cylinder	Bore dia x Rod dia x Stroke	Ø120 x Ø85 x 1290mm
	Cushion	Extend only
Arm cylinder	Bore dia x Rod dia x Stroke	Ø140 x Ø100 x 1510mm
	Cushion	Extend and retract
Bucket cylinder	Bore dia x Rod dia x Stroke	Ø125 x Ø85 x 1055mm
	Cushion	Extend only
2 Piece boom Adjust cylinder	Bore dia x Rod dia x Stroke	Ø160 x Ø100 x 425mm
	Cushion	Extend only

Discoloration of cylinder rod can occur when the friction reduction additive of lubrication oil spreads on the rod surface.

Discoloration does not cause any harmful effect on the cylinder performance

9) SHOE

Item		Width	Ground pressure	Link quantity	Overall width
MONO BOOM	Standard	500mm(20")	0.56kgf/cm ² (7.96psi)	49	2500mm(8' 2")
	Option	600mm(24")	0.47kgf/cm ² (6.68psi)	49	2600mm(8' 6")
		700mm(28")	0.41kgf/cm ² (5.83psi)	49	2700mm(8' 10")
2 PIECE BOOM	Standard	500mm(20")	0.56kgf/cm ² (7.96psi)	49	2500mm(8' 2")
	Option	600mm(24")	0.48kgf/cm ² (6.83psi)	49	2600mm(8' 6")

10) BUCKET

Item		Capacity		Tooth quantity	Width		
		SAE heaped	CECE heaped		Without side cutter	With side cutter	
R210NLC-7	STD	0.87m ³ (1.14yd ³)	0.75m ³ (0.98yd ³)	5	1090mm(42.9")	1210mm(47.6")	
	OPT		0.51m ³ (0.67yd ³)	0.45m ³ (0.59yd ³)	3	700mm(27.6")	820mm(32.3")
			0.80m ³ (1.05yd ³)	0.70m ³ (0.92yd ³)	5	1000mm(39.4")	1120mm(44.1")
			1.20m ³ (1.57yd ³)	1.00m ³ (1.31yd ³)	6	1400mm(55.1")	-
			1.34m ³ (1.75yd ³)	1.15m ³ (1.50yd ³)	6	1550mm(61.0")	-
			0.74m ³ (0.97yd ³)	0.65m ³ (0.85yd ³)	5	915mm(36.0")	-
			0.90m ³ (1.18yd ³)	0.80m ³ (1.05yd ³)	5	1070mm(42.1")	-
			1.05m ³ (1.37yd ³)	0.92m ³ (1.20yd ³)	5	1220mm(48.0")	-
			≡0.87m ³ (1.14yd ³)	0.75m ³ (0.98yd ³)	5	1140mm(44.9")	-
			0.75m ³ (0.98yd ³)	0.65m ³ (0.85yd ³)	-	1810mm(71.3")	-

: Heavy duty bucket

≡ : Rock bucket(Heavy)

: Slope finishing bucket

9. RECOMMENDED OILS

Use only oils listed below or equivalent.
Do not mix different brand oil.

Service point	Kind of fluid	Capacity (U.S. gal)	Ambient temperature °C (°F)								
			-20 (-4)	-10 (14)	0 (32)	10 (50)	20 (68)	30 (86)	40 (104)		
Engine oil pan	Engine oil	24.0(6.3)					SAE 30				
			SAE 10W								
			SAE 10W-30								
			SAE 15W-40								
Swing drive	Gear oil	6.2(1.6)		SAE 85W-140							
Final drive		5.4 × 2 (1.4 × 2)									
Hydraulic tank	Hydraulic oil	Tank; 180(48) System; 270(71)	ISO VG 32								
			ISO VG 46								
			ISO VG 68								
Fuel tank	Diesel fuel	310(82)	ASTM D975 NO.1								
			ASTM D975 NO.2								
Fitting (Grease nipple)	Grease	As required	NLGI NO.1								
			NLGI NO.2								
Radiator (Reservoir tank)	Mixture of antifreeze and water 50 : 50	35(9.2)	Ethylene glycol base permanent type								

SAE : Society of Automotive Engineers
API : American Petroleum Institute
ISO : International Organization for Standardization
NLGI : National Lubricating Grease Institute
ASTM : American Society of Testing and Material